

# TEMPORARY PEDESTRIAN ACCESS ROUTES HANDBOOK



**Caltrans**

**2020**

***This handbook provides information for workers in the field for accommodating pedestrians with disabilities through and around work zones.***

## Introduction

Caltrans maintains safe and convenient access for users of its roads, highways, and facilities. The needs and control of road users are an essential part of highway construction, utility work, maintenance operations, and management of traffic incidents through use of temporary traffic control zones. Caltrans developed this handbook to help field staff accommodate pedestrians, including persons with disabilities, through and around work zones.

### Related Caltrans Standards

- Section 7-1.02A, “General,” of the *Standard Specifications* requires the contractor to comply with current laws, regulations, orders, and decrees.
- Section 7-1.04, “Public Safety,” requires that the contractor provide for the safety of the public during construction.
- Section 12, “Temporary Traffic Control,” directs the contractor’s attention to the *California Manual on Uniform Traffic Control Devices* (California MUTCD).
- Section 12-4.04, “Temporary Pedestrian Access Routes,” provides the requirements for constructing a temporary pedestrian access route.

### General Requirements

Verify that the contractor follows these guidelines:

If the contractor’s activity requires closing a pedestrian pathway, another pathway must be made available nearby, off the traveled way. This

pathway must replicate, to the maximum extent possible, the characteristics of the existing pathway. Special care should be given to areas in schools and senior citizen center locations.

Advanced signing notification of sidewalk closures must be provided.

Pedestrian facilities must be maintained in good condition and kept clear of obstruction.

Traffic control devices, equipment, and other construction materials and features must not intrude into the usable width of the sidewalk, temporary pathway, or other pedestrian facility.

Signs and other devices mounted lower than 7 feet above the temporary pedestrian pathway should not project more than 4 inches into accessible pedestrian facilities.

Where pedestrian openings through falsework are required, a temporary pedestrian facility with protective overhead covering must be provided during all bridge construction activities.

Hand railings on each side of temporary pedestrian facilities must be provided as necessary to protect pedestrian traffic from hazards due to work activities or adjacent vehicular traffic.

Protective overhead covering must be provided as necessary to ensure protection from falling objects and dripping from overhead structures.

When affected by an activity, a continuous unobstructed pathway connecting all existing accessible elements (parking lots, bus stops) through the project must be maintained.

The resident engineer must request a work plan if the affected temporary pedestrian access route is not identified in the contract plans. The contractor is responsible for accommodating pedestrians through the work zone whenever the work disrupts pedestrian facilities.

## California MUTCD Requirements

The following three items should be considered when planning for pedestrians in temporary traffic-control zones:

Pedestrians should not be led into conflicts with work site vehicles, equipment, and operations.

Pedestrians should not be led into conflicts with vehicles moving through or around the work site.

Pedestrians should be provided with a reasonably safe, convenient, and accessible path that replicates as nearly as practical the most desirable characteristics of the existing sidewalk or footpath.

## General Considerations

The contractor should consider the following items when planning the temporary facility:

A pedestrian route must not be severed or moved for non-construction activities such as parking for vehicles and equipment.

A barrier, detectable by a person with a visual disability traveling with the aid of a long cane, must be placed across the full width of the closed sidewalk they would normally use (See Figure 1.)

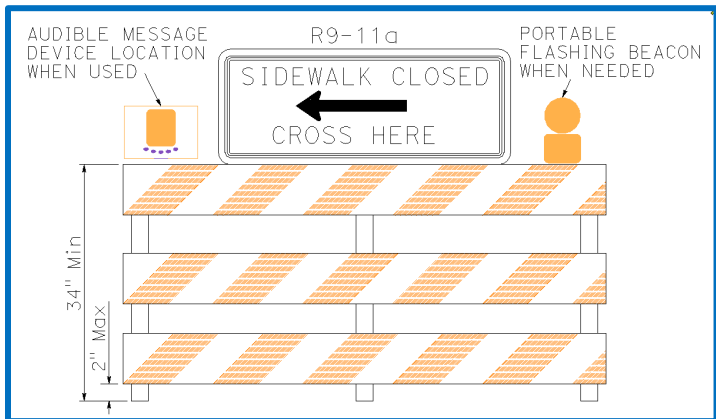

Figure 1 Closure Barrier

A reasonably safe route that does not involve crossing the roadway must be provided. If this is not possible, advance signing should direct pedestrians to cross to the opposite side of the roadway. In urban and suburban areas with high vehicular traffic volumes, place these signs at intersections. (See Figure 2.)

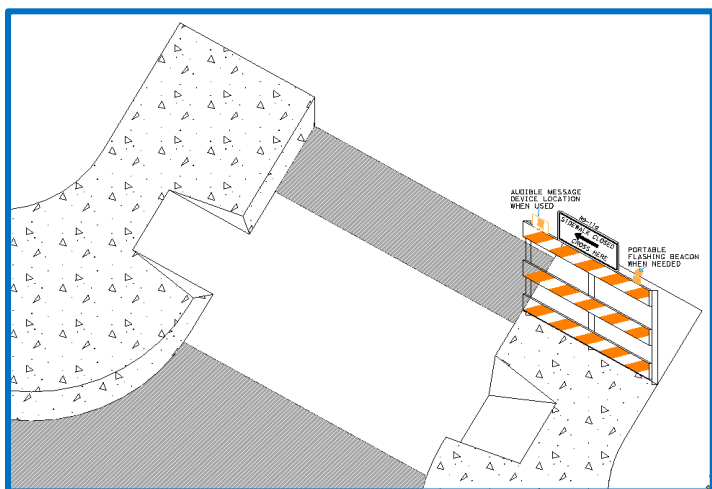

Figure 2 Sidewalk Closure

- Midblock work sites should not induce pedestrians to attempt skirting the work site or make a midblock crossing. (See Figures 3 and 4.)
- Pedestrian movements should be separated from both work site activity and vehicular traffic. When pedestrians are routed adjacent to live traffic, barrier protection must be provided to prevent vehicles from entering the pedestrian facility.

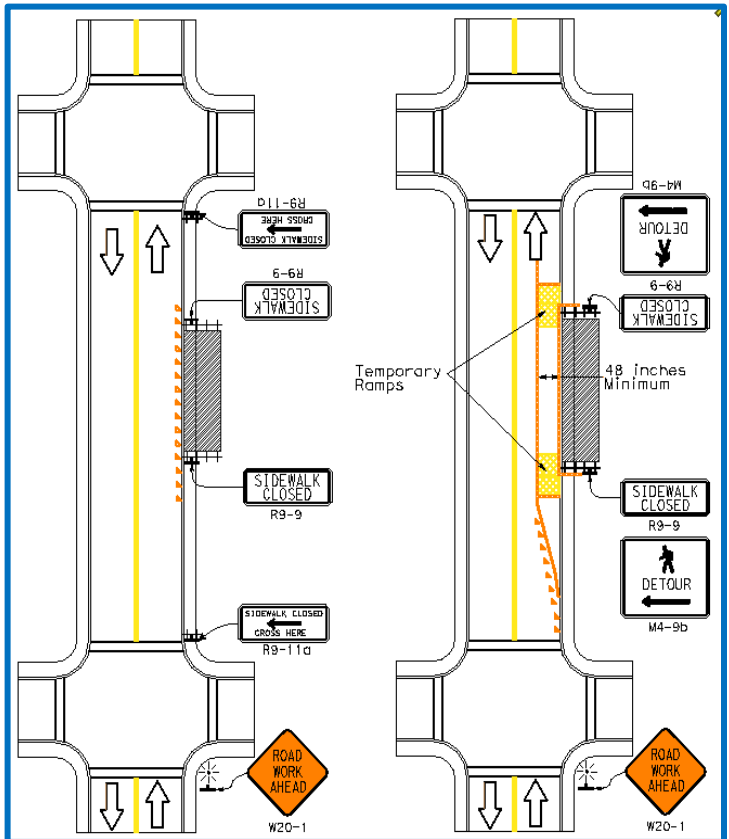

Figure 3 Sidewalk Detour or Diversion

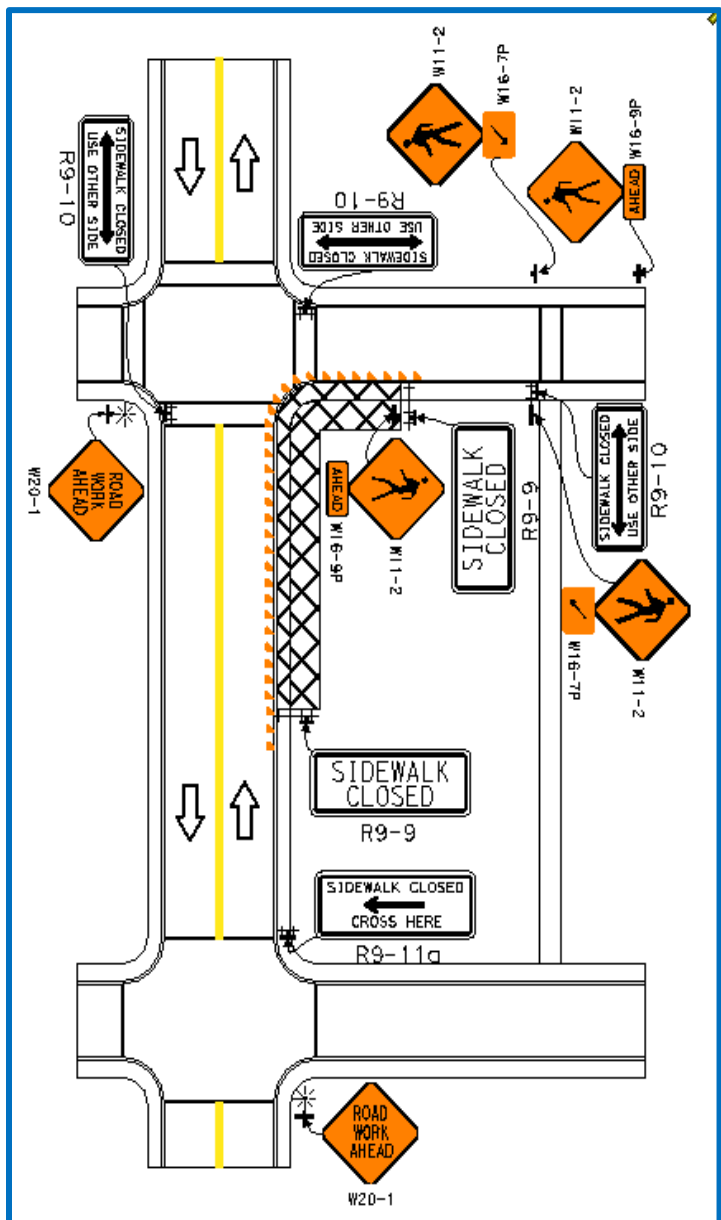

Figure 4 Crosswalk Closures and Pedestrian Detours



- Tape, rope, or plastic chain strung between devices as controls for pedestrian movements must not be used. They are not readily detectable by persons with a visual disability.
- Where barricades channel pedestrians, continuous detectable bottom and top rails must be used, with no gaps between individual barricades for users of long canes. The bottom of the bottom rail must be no higher than 2 inches above the ground surface. The top of the top rail must be at least 32 inches above the ground. Refer to Part 6, Sections 6F.63 and 6F.68 of the California MUTCD (See Figure 5.)

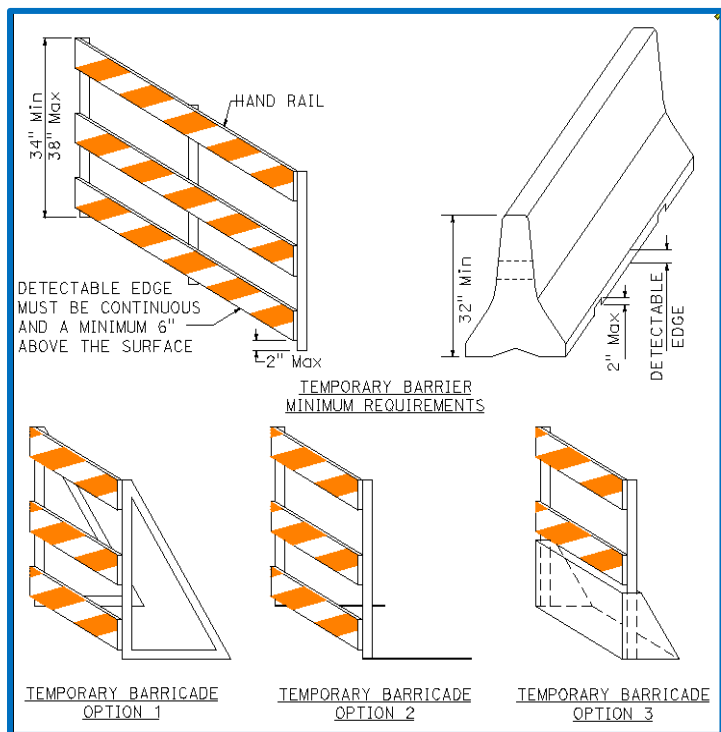

Figure 5 Channelizing Device Options

During the inspection process, check that all contractor- installed finished elements comply with dimensions and installation requirements. Check all slopes using a 2-foot-long smart level on elements with a dimension of 4 feet or less, and a smart level at least 4 feet long on elements with a dimension greater than 4 feet.

**Do not exceed any of the maximums shown in the requirements. They are absolute.**

For permanent facilities refer to:

*Permanent Pedestrian Facilities ADA Compliance Handbook.*

Caltrans Design Information Bulletin 82, "Pedestrian Accessibility Guidelines for Highway Projects."

## ADA Checklist

Document Temporary Pedestrian Access Routes compliance using:

- Form CEM-2301, “Temporary Pedestrian Access Route Compliance Inspection Report”
- Form CEM-2302, “Temporary Pedestrian Access Route Weekly Inspection Report”
- Form CEM-2303, “Temporary Pedestrian Access Route Sidewalk Detour Inspection Report”
- Form CEM-2311 “Temporary Pedestrian Access Route Contractor Compliance Report”
- Form CEM-2312 “Temporary Pedestrian Access Route Contractor Weekly Report”

The ADA compliance inspection forms are available at: <http://www.dot.ca.gov/hq/construc/forms.htm>

File the completed forms in Category 23 of the project files.

### Accessible Route Basics

- The path must be stable, firm, and slip resistant. Pedestrian facilities must be surfaced with minor HMA or commercial-quality bituminous material, commercial-quality concrete, or wood. Dirt is not an acceptable surface.
- The surface should be smooth and continuously hard throughout the entire length of the temporary pedestrian facility. No abrupt changes should exist in grade or terrain that could cause tripping or be a barrier to wheelchair use.

- Surface discontinuities must not exceed  $\frac{1}{2}$  inch maximum. Vertical discontinuities between  $\frac{1}{4}$  inch and  $\frac{1}{2}$  inch should be beveled at a maximum of 2:1 or flatter, and bevels should be constant across the entire level change. New surfaces must not have vertical surface discontinuities. Curb ramps, landings, and gutter areas must not have surface discontinuities. (See Figure 6.)

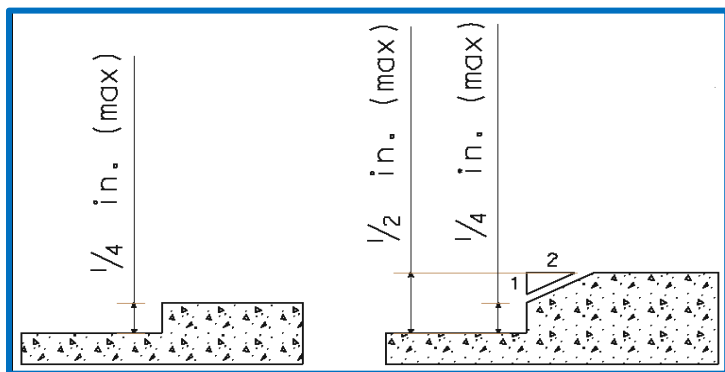

Figure 6 Surface Discontinuities

- On pedestrian access route joints and gratings, surface openings must not permit passage of a sphere larger than  $\frac{1}{2}$  inch. Place horizontal surface openings so that the long dimension is perpendicular to the dominant direction of travel. (See Figure 7.)
- The cross slope must be no greater than 1:50 (2 percent).
- The longitudinal slope must be no greater than 1:20 (5 percent). Otherwise, meet the ramp requirements discussed below. For street facilities, the running slope may follow the adjoining street.

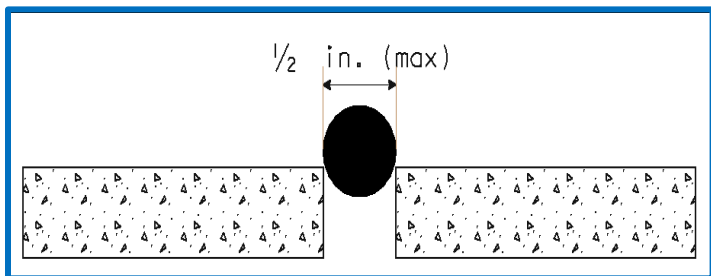

Figure 7 Surface Openings

- When feasible, a width of 60 inches should be maintained throughout the pedestrian route. (See Figure 8.)
- When it is not possible to maintain a width of 60 inches, a 60 x 60-inch passing space must be provided at least every 200 feet to allow individuals in wheelchairs to pass. (See Figure 9.)
- The pedestrian route must have a clear width of no less than 48 inches. Verify that no fixed objects such as cabinets or poles, will reduce the route width at any point. (See Figure 10.)
- Signs and other devices mounted lower than 7 feet above the temporary pedestrian pathway should not project more than 4 inches into accessible pedestrian facilities. Refer to Part 6, Section 6D.02 of the California MUTCD. (See Figure 11.)
- Objects must not protrude into the pedestrian route. Check with the project engineer for exceptions.
- Vertical clearance must be 80 inches minimum.

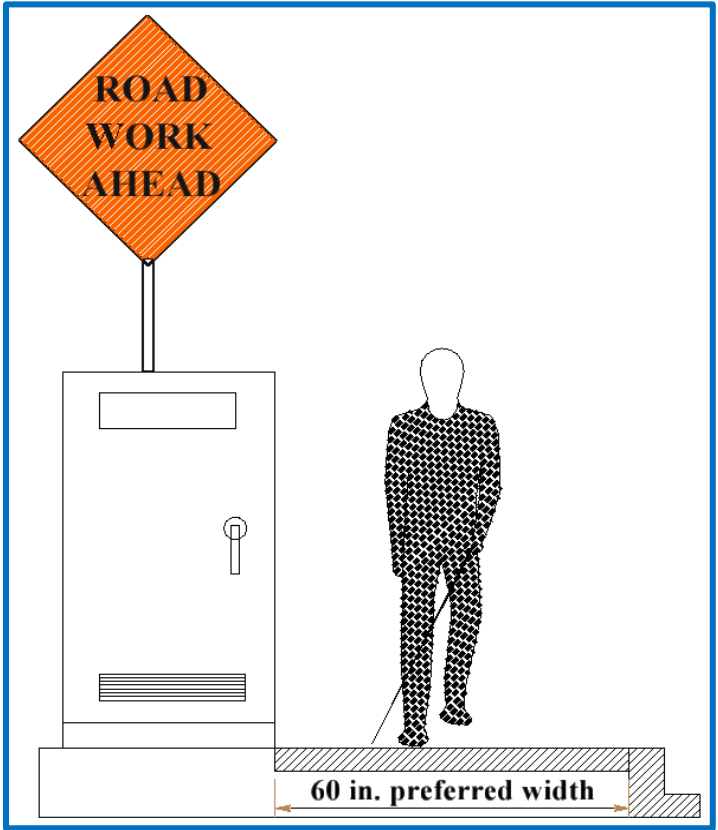

Figure 8 Preferred Pedestrian Route Width

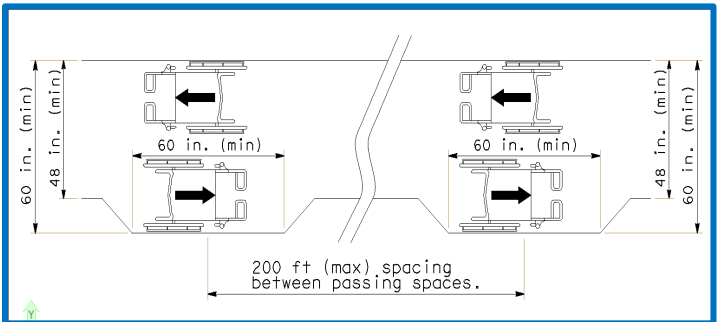

Figure 9 Passing Space

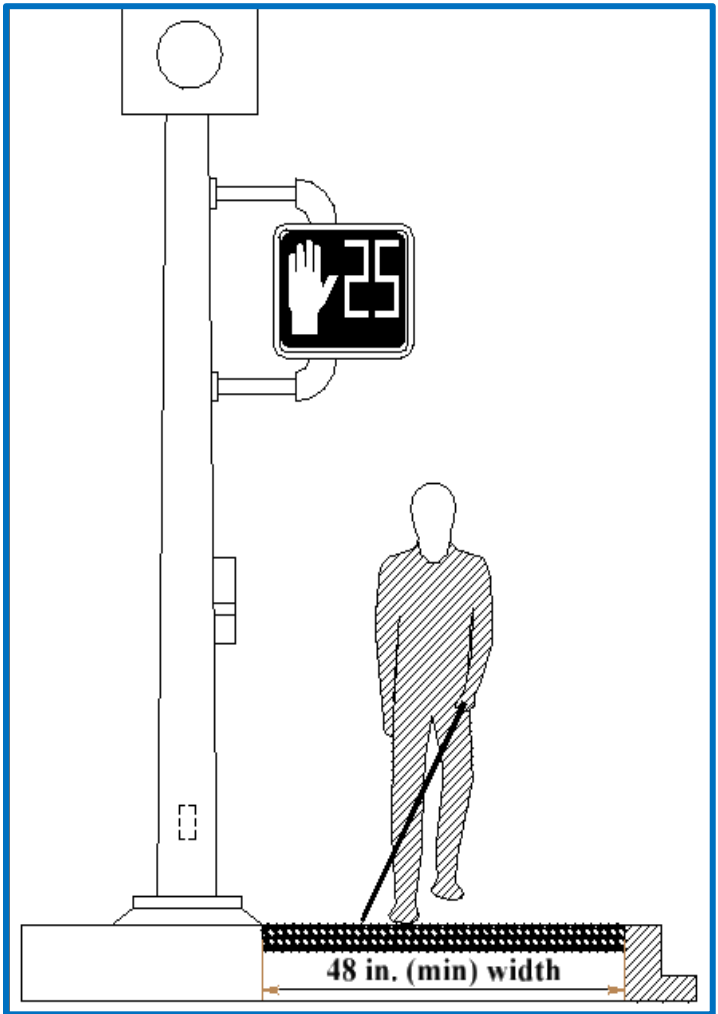

Figure 10 Minimum Pedestrian Route Width

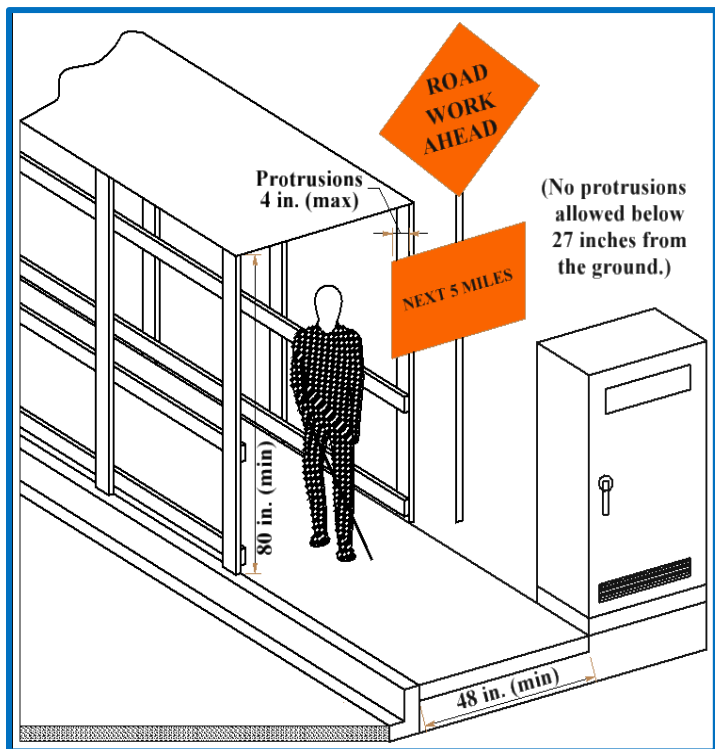

Figure 11 Protruding Objects

- If the path requires a 180-degree turn, the turning pad must be at least 60 inches deep. (See Figure 12.)

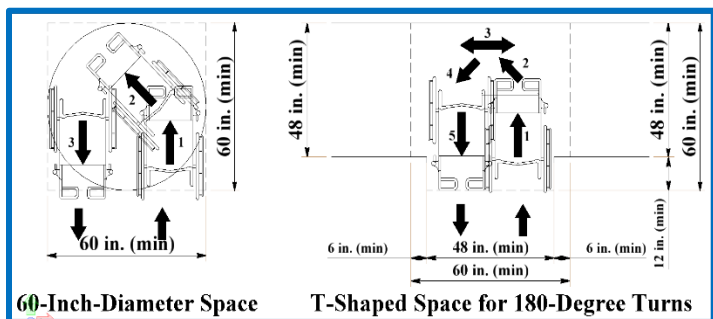

Figure 12 Turning Space (ADAAG)



- Pedestrians must be channelized when routed off existing pedestrian routes (See Figure 13.)

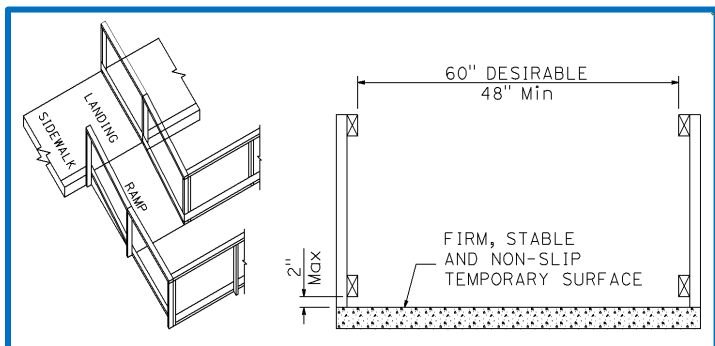

Figure 13 Channelized Temporary Pedestrian Route

- Access to nearby temporary transit stops must be provided.
- Pedestrians may need temporary nighttime lighting. Refer to contract plans and specifications for requirements.

## Ramps

- The longitudinal slope must be no greater than 1:12 (8.33 percent).
- Rise must be no greater than 30 inches.
- Each ramp must have level landings at the bottom and top. A landing must be as wide as the run leading to it and have a minimum length of 60 inches. (See Figure 14.)
- Ramps must have edge protection at least 2 inches high on each side.
- Ramps must have handrails 34 to 38 inches above the walkway surface if the rise is greater than 6 inches.

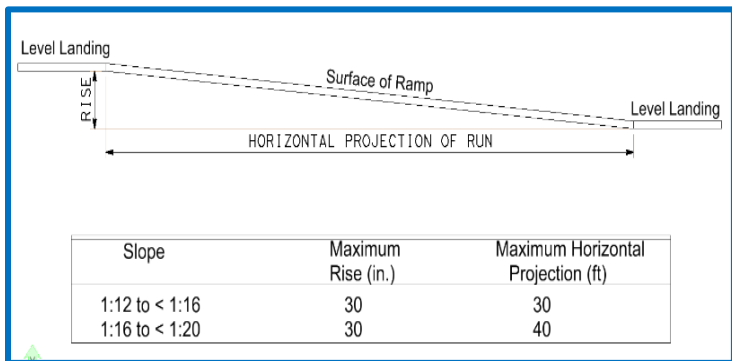

Figure 14 Components of a Single Ramp and Sample Ramp Dimensions (ADAAG)

- Curb ramps, landings, and blended transitions connecting to a street must have a detectable warning surface.

## Curb Ramps

- The longitudinal slope must be no greater than 1:12 (8.33 percent).
- Curb ramps must have edge protection at least 2 inches high on each side if the curb ramp does not have flares and the rise is greater than 6 inches, (See Figure 15.)

Curb ramps to be constructed on sites or facilities where space limitations prohibit the use of a 1:12 slope or less may have slopes and rises as follows:

- A slope between 1:10 and 1:12 is allowed for a maximum rise of 6 inches.
- A slope between 1:8 and 1:10 is allowed for a maximum rise of 3 inches.
- A slope steeper than 1:8 is not allowed.

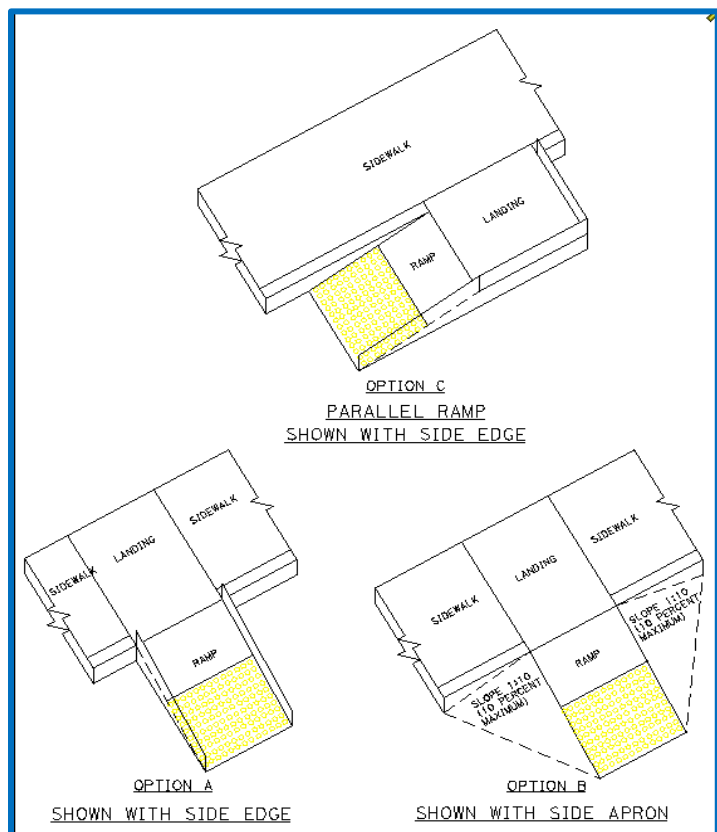

Figure 15 Temporary Curb Ramp Options

## Pedestrian Push Buttons

- The pedestrian push button must have an unobstructed forward reach. For the exact height of the button, refer to the *Standard Plans*. (See Figure 16.)
- If the pedestrian push button requires a side reach, obstructions at the bottom cannot extend more than 24 inches from base. For the exact height of the button, refer to the *Standard Plans*. (See Figure 17.)

- A pedestrian push button used to provide equivalent temporary traffic control information to pedestrians with visual disabilities should be equipped with a locator tone to notify them that a special accommodation is available and help them locate the button.

## **Audible Information Devices**

A wide range of pedestrians might be affected by temporary traffic-control zones. All pedestrians need a clearly delineated and usable travel path.

A speech message by an audible information device is the preferred way of providing information equivalent to visual signage to notify pedestrians with visual disabilities of sidewalk closures.

- ✓ Devices that provide speech messages in response to passive pedestrian actuation (motion sensor) are preferred.
- ✓ Other devices that continuously emit a message or a message in response to use of a pedestrian push button are also acceptable.
- ✓ Signage information can also be transmitted to personal receivers, but currently pedestrians with visual disabilities are not likely to carry or use such receivers in temporary traffic-control zones.

Audible information devices may not be needed if detectable channelizing devices make an alternate route of travel evident to pedestrians with visual disabilities.

Objects that require a forward reach must be placed no lower than 15 inches and no higher than 48 inches.

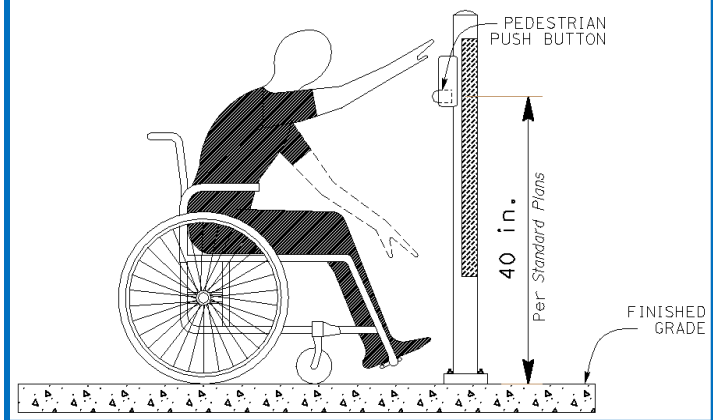

Figure 16 High Forward Reach (ADAAG)

Objects that require a side reach across any obstacles must be placed no lower than 34 inches and no higher than 46 inches.

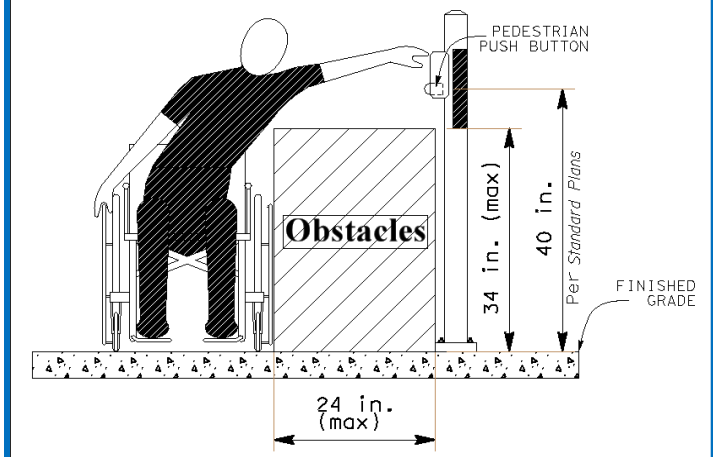

Figure 17 High Side Reach (ADAAG)

