

DIST	COUNTY	ROUTE	POST MILES TOTAL PROJECT	SHEET No.	TOTAL SHEETS
X	X	X	X	X	X
REGISTERED CIVIL ENGINEER			X	DATE	
PLANS APPROVAL DATE					
The State of California or its officers or agents shall not be responsible for the accuracy or completeness of electronic copies of this plan sheet.					

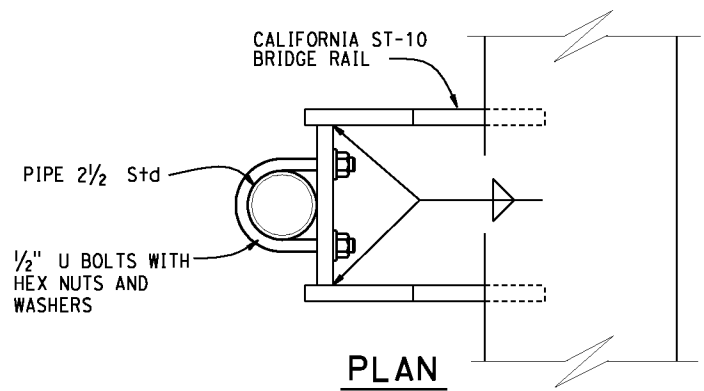

PLAN

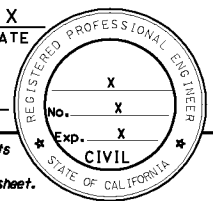
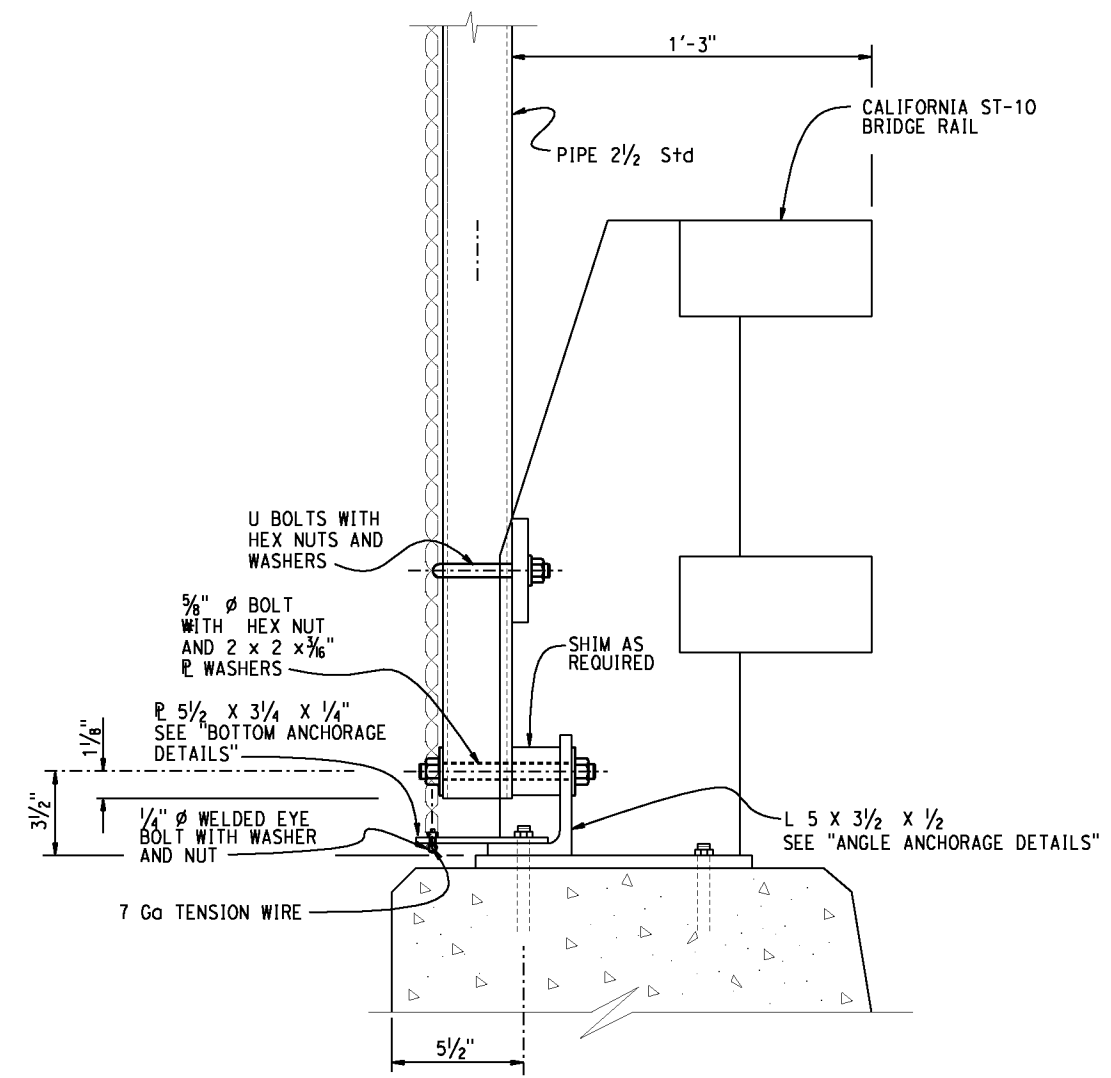

ELEVATION SECTION A-A
3" = 1'-0"

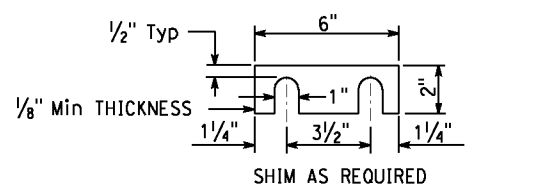

RAILING SHIM DETAILS
3" = 1'-0"

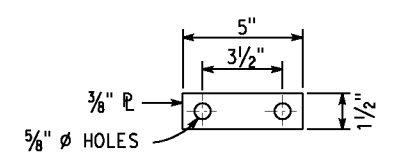

SPACER PLATE
3" = 1'-0"

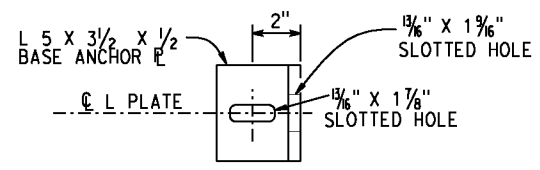

PLAN

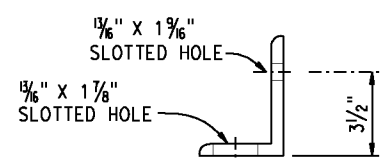

ELEVATION

ANGLE ANCHORAGE DETAILS
3" = 1'-0"

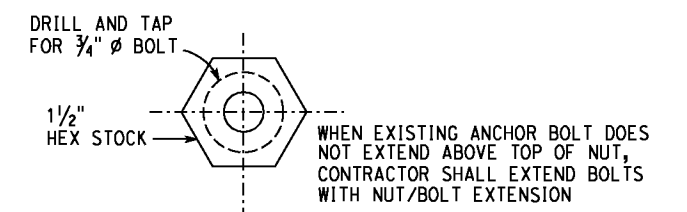

NUT/BOLT EXTENSION
NO SCALE

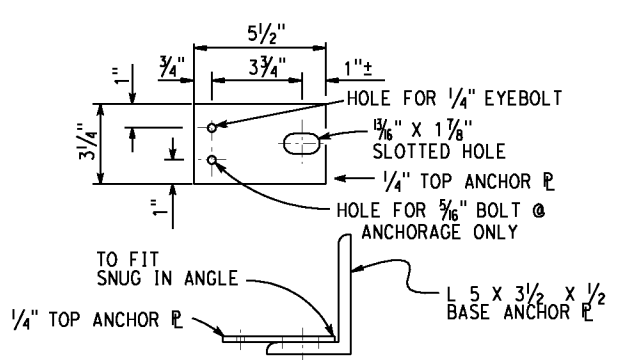

BOTTOM ANCHORAGE DETAILS
3" = 1'-0"

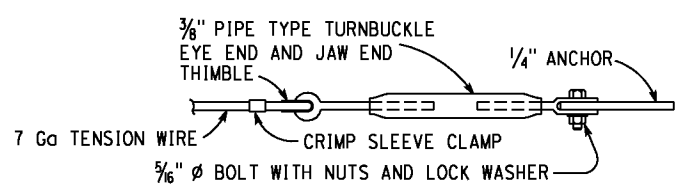

STANDARD DRAWING	
FILE NO. xs16-150-2	APPROVAL DATE <u>July 2011</u>

STATE OF CALIFORNIA	
DEPARTMENT OF TRANSPORTATION	

DIVISION OF ENGINEERING SERVICES	
BRIDGE NO. X	
POST MILE X	

CHAIN LINK RAILING TYPE 2 - ST-10	
DETAILS NO. 2	

DATE PLOTTED => \$DATE USERNAME => \$USER TIME PLOTTED => \$TIME