

DIST	COUNTY	ROUTE	POST MILES TOTAL PROJECT	SHEET No.	TOTAL SHEETS
X	X	X	X	X	X

REGISTERED CIVIL ENGINEER	DATE
	X

PLANS APPROVAL DATE

The State of California or its officers or agents shall not be responsible for the accuracy or completeness of electronic copies of this plan sheet.

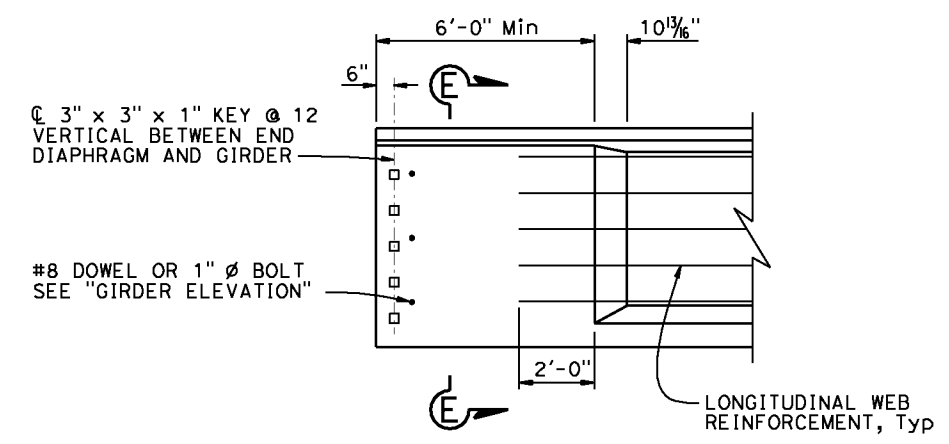
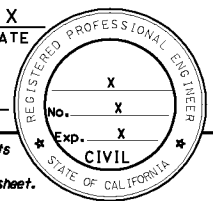

OPTIONAL END BLOCK - ELEVATION

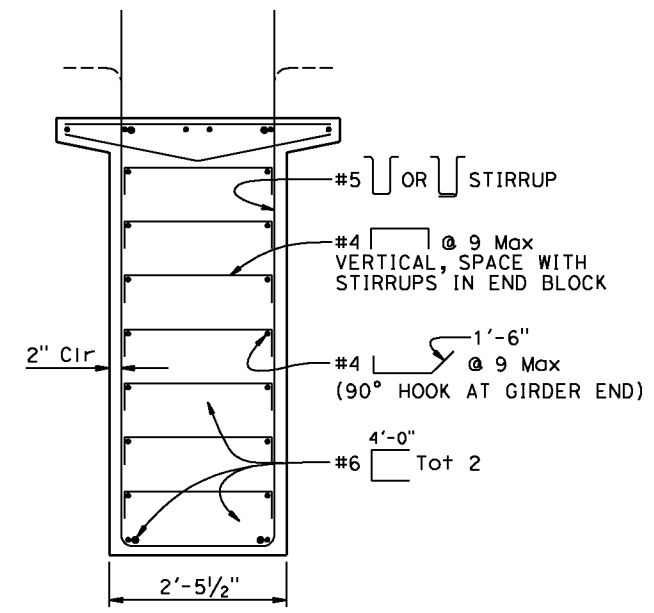

NOTE:
For details not shown, see "TYPICAL GIRDER SECTION" detail

SECTION E-E

NOTE:
For "GIRDER ELEVATION" and "TYPICAL GIRDER SECTION", see "PC/PS BULB-TEE GIRDER (HARPED STRANDS)" sheet

- NOTES:
- For details shown but not noted, see "TYPICAL GIRDER SECTION" detail
 - W8 WWR not shown

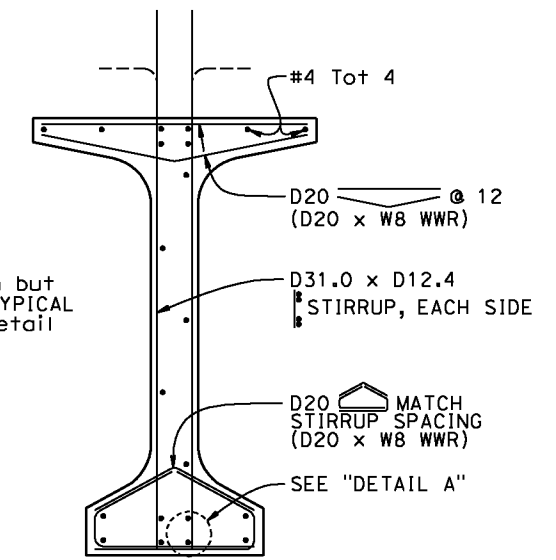

WELDED WIRE REINFORCEMENT (WWR) ALTERNATIVE

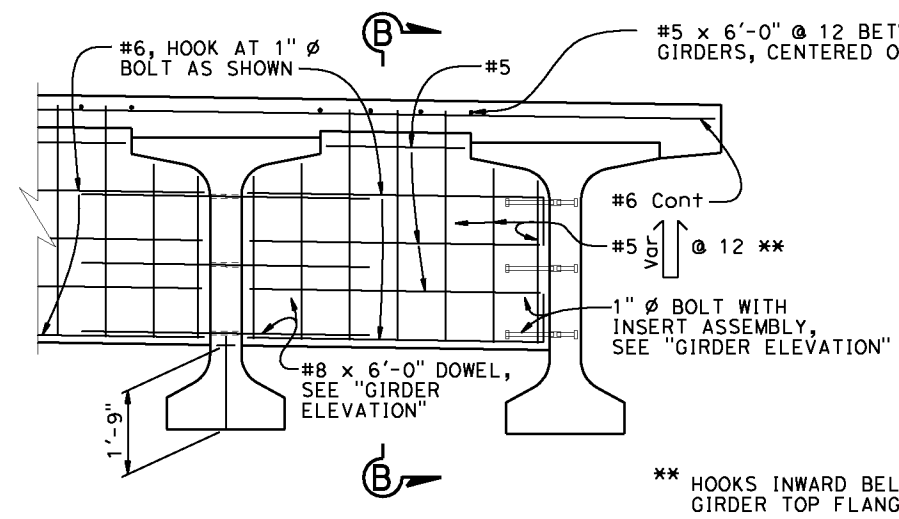

INTERMEDIATE DIAPHRAGM

** HOOKS INWARD BELOW GIRDER TOP FLANGE

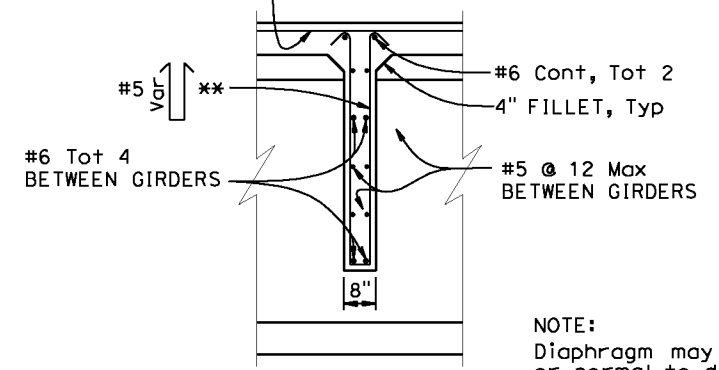

SECTION B-B

NOTE:
Diaphragm may be vertical or normal to deck grade

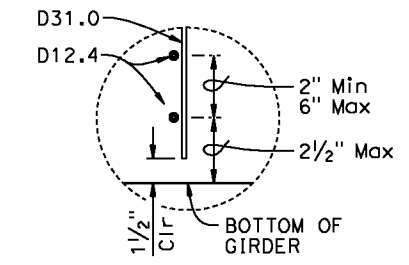

DETAIL A

- NOTES:
- Bottom of stirrup WWR detail shown, top similar
 - Longitudinal wire area shall be 40% or greater of vertical deformed wire's area

NO SCALE

STANDARD DRAWING
FILE NO. xs1-122-2
APPROVAL DATE <u>July 2011</u>

STATE OF CALIFORNIA	DIVISION OF ENGINEERING SERVICES
DEPARTMENT OF TRANSPORTATION	

BRIDGE NO.	X
POST MILE	X
PC/PS BULB-TEE GIRDER (MISCELLANEOUS DETAILS)	

DATE PLOTTED => \$DATE USERNAME => \$USER TIME PLOTTED => \$TIME