

TRANSPORTATION ELECTRICAL EQUIPMENT SPECIFICATIONS

CHAPTER 7

Revision 2.2



**STATE OF CALIFORNIA
DEPARTMENT OF TRANSPORTATION**

© 2025 California Department of Transportation. All Rights Reserved.



CHAPTER 7
ATC CABINET

REVISION HISTORY

Sections:

Section 7.3.1.2: Revised cabling specification

Section 7.3.1.5: Removed isolation transformer or other means be utilized to isolate the CMU.

Section 7.3.2: Removed circuit breaker reaction time requirement

Section 7.3.2: Updated language for storing spare HDFU fuses

Section 7.3.2: Added requirement for covers over the stop time and flash switches

Section 7.3.2: Clarified the SIU address of the assembly

Section 7.3.2.1: Moved HDSP/HDFU requirement to section 7.3.2.1.

Section 7.3.2.1: Added specifications for optional 32-channel output file

Section 7.3.2.2: HDSP/HDFU requirement moved from section 7.3.2.1

Section 7.3.2.3: Added new section to provide an additional red datakey with the cabinet

Section 7.3.3: Removed terminal connector fastener screw accessibility requirement

Section 7.3.3.1: Moved Flash Transfer Relay requirements to section 7.3.3.2.

Added specification for 2nd FOTA. Added definition for flasher output functions.

Section 7.3.3.1: All field terminal plugs shall now termination minimum (4) conductors.

Section 7.3.3.2: Flash Transfer Relay requirement moved from section 7.3.3.1.

Added definition for flasher output functions.

Section 7.3.4.1: Clarified SIU address of input assemblies

Section 7.3.4.2: Simplified Input Assembly #2 language

Section 7.3.4.3: Added specification for Optional Input Assembly #3

Section 7.3.5.1: Revised terminal connector type.

Section 7.3.5.2: Simplified FITA #2 language

Section 7.3.5.3: Added specification for FITA #3

Section 7.3.7: Added communications connector requirement

Section 7.3.7: Added requirement for additional slack of SDLC & Power connections to assembly

Section 7.3.8: Added requirements for LED indications

Section 7.3.8: Added communications connector requirement

Section 7.3.8: Added requirement for additional slack of SDLC & Pwr connections to assembly

Section 7.3.8.2: Updated power and fuse requirements

Section 7.3.9: Updated plug requirements on the rear of the assembly

Section 7.3.9: Added cabling requirement from the SA to FOTA
Section 7.3.9: Added fuse holder requirements for assembly
Section 7.3.9: Added spare HDFU fuse labeling requirement
Section 7.3.10: Removed language specifying power supply output connector.
Section 7.3.10: Power supply model changed from 2216-2412 to 2216-24.
Section 7.3.11: Updated language describing 4 auxiliary DC output connectors
Section 7.3.11: Updated quantity of DC output connectors on the assembly
Section 7.3.12: Updated language for the power input of the power strip & direction of receptacles
Section 7.3.12: Clarified dimension and control requirements
Section 7.3.13: Removed energy-efficient ethernet requirement of the network switch
Section 7.3.13: Clarified dimension requirement and increased maximum depth requirement from 14" to 18"
Section 7.3.14: Updated language for the power over ethernet power supplies
Section 7.3.15: Removed language regarding ABS cover on drawer shelf
Section 7.3.18: Updated assembly rack unit requirement and language
Section 7.4.1 & 7.4.2: Updated language to match language found in 5301v2 Standard.
Section 7.4.2: Updated language to detail the quantity of programmers
Section 7.4.3: Removed language requiring all connections to be toolless
Section 7.3.8: Railroad assembly's power input connector changed to 3 positions.

Layouts:

A7-1: Updated Y-dimension of rack. Removed ear bolts.
A7-2: Cage# 3's inside height dimensions changed to 64.5" & outside to 66"
A7-3: In the generator panel, added a generator cord slot.
A7-4: Adjusted mounting detail for adjustable DIN rail assembly
A7-4: Adjusted the mounting layout of assemblies in the cabinet by 1.75"
A7-6: Adjusted mounting detail for adjustable DIN rail assembly
A7-5 Adjusted the mounting detail for the network switch by 1.75"
A7-8: Add layout for the pull-out drawer with side pin support
Note: Subsequent layouts numbering changed due to addition of pull-out drawer.
A7-10: Updated to show (2) antenna brackets are required.
A7-11: Added cable pass-through holes and mounting holes for the drawer shelf on the side panels. Adjusted position of cable raceways. Removed the clear area requirement.

A7-12: Added cable pass-through holes and mounting holes for the drawer shelf on the side panels. Adjusted position of cable raceways. Removed the clear area requirement.

A7-13: Updated thermostat one-line diagram to include a test button

A7-13: Updated thermostat mounting details

A7-15: Updated quantity of DC output connectors, the +12VDC removed from the plug.

A7-16: Added FOTA (1-16 ch) layout. Renumbered the sequential layouts.

A7-17: Revised notes to better synchronize with the newer A7-16 layout.

A7-21: Removed requirement for +12VDC for input/output assembly

A7-23: Added new sheet for FITA labels. Renumbered the subsequent sheets.

A7-24: Changed title of layout and added reference of auxiliary I/O assembly

A7-24: Added specification for I/O addressing of Auxiliary I/O Assembly.

A7-26: Railroad preemption assembly power connector moved to A7-26 from A7-22.

A7-26: Now a (3) position connector.

A7-27: Added Railroad input/output assembly addresses

A7-28: Added Railroad preemption assembly details. Two fuses for health circuit.

Changed the DC Input plug to (3) positions – Eq Gnd, GND & 24VDC.

A7-29: Added Cabinet equipment mounting details for 352ATC, IFA#3

A7-30: Added Cabinet equipment mounting details for 352ATC, OFA#2

A7-31: Added Cabinet equipment mounting details for 352ATC, IFA#3, OFA#2

A7-32: Added Cabinet equipment mounting details for 362ATC, IFA#3 FRONT

A7-33: Added Cabinet equipment mounting details for 362ATC, IFA#3 REAR

A7-34: Added Cabinet equipment mounting details for 362ATC, OFA#2 FRONT

A7-35: Added Cabinet equipment mounting details for 362ATC, OFA#2 REAR

A7-36: Added Cabinet equipment mounting details for 362ATC, IFA#3, OFA#2 FRONT

A7-37: Added Cabinet equipment mounting details for 362ATC, IFA#3, OFA#2 REAR

CHAPTER 7-SECTION 1

GENERAL REQUIREMENTS AND CABINET MODEL COMPOSITION

7.1.1 General

Advanced Transportation Controller (ATC) Cabinet shall meet the Intelligent Transportation System (ITS) Cabinet Standard ATC 5301 v02.02. Additionally, the cabinet shall meet these requirements. In the event of specifications conflict, these requirements shall supersede the ATC Standard.

7.1.2 Composition

Unless otherwise specified, the model shall be furnished, ready for operation with the following composition.

Cabinet	Housing	Doors
Model 352ATC	No. 1C	2
Model 362ATC	No. 3	4

7.1.2.1 Model 352ATC

Model 352ATC cabinet shall consist of:

• Mounting Cage #3	• DC Power Supply
• Output Assembly (16-Channel)	• SB1/SB2, Clean AC, & DC Power Bus Assembly
• (9) High Density Switch Pack Model 2202	
• (1) Cabinet Monitor Model 2212	• Managed AC Power Strip
• Field Output Termination Assembly	• Power Over Ethernet Switch
• (2) Input Assembly (24-Channel)	• Power Over Ethernet Power Supply
• (2) Field Input Termination Assembly	• Drawer Shelf
• Auxiliary Display Unit Model 2220	• (2) Equipment Shelves (Half-Depth)
• Auxiliary Input/Output Assembly	• (2) Adjustable Din Rail
• Service Assembly	• Equipment Shelf (Full-Depth)
	• (3) Serial Interface Unit Model 2218

7.1.2.2 Model 362ATC

First mounting cage shall consist of:

• Mounting Cage #1	• Auxiliary Input/Output Assembly
--------------------	-----------------------------------

• Output Assembly (16-Channel)	• Service Assembly
• (9) High Density Switch Pack Model 2202	• DC Power Supply
• (1) Cabinet Monitor Model 2212	• SB1/SB2, Clean AC, & DC Power Bus Assembly
• Field Output Termination Assembly	
• (2) Input Assembly (24-Channel)	• Drawer Shelf
• (2) Field Input Termination Assembly	• Equipment Shelf (Half-Depth)
• Auxiliary Display Unit Model 2220	• (3) Serial Interface Unit Model 2218
• Adjustable DIN Rail	

Second mounting cage shall consist of:

• Mounting Cage #1	• Drawer Shelf
• Managed AC Power Strip	• Equipment Shelf (Half-Depth)
• Power Over Ethernet Switch	• (2) Battery Pull-Out Drawer
• Power Over Ethernet Power Supply	• (1) Adjustable DIN Rail

The cabinet shall meet the following general requirements of Chapter 6: (6.1.2), (6.1.3), (6.1.4), (6.1.6).

CHAPTER 7-SECTION 2
CABINET HOUSING CONSTRUCTION

7.2.1 Housing Construction

The cabinet shall meet the housing requirements of Chapter 6. The housing interior shall be white in color.

7.2.1.1 Lifting Eyes

The housing shall be provided with 2 lifting eyes for placing the cabinet on its foundation. Each eye opening shall have a minimum diameter of 0.75 in. Each eye shall be able to support a weight load of 1000 pounds. Lifting eyes shall rotate without the use of tools.

7.2.2 Cabinet Cage

7.2.2.1 Cabinet Cage Construction

The cage shall meet the cabinet cage requirements of Chapter 6.

7.2.2.2 Spare Rail Screws

Eight (8) spare EIA rail screws shall be provided on each mounting cage.

7.2.3 Model 362ATC Generator Panel

The panel assembly must be waterproof and feature a drain that directs water outside, preventing any accumulation within the unit. The generator panel shall be equipped with a lock that is keyed for a Corbin 2 type, or equal. The keys shall be removable in the locked position only. The panel shall have a slot for generator cord, allowing the panel to remain locked while the generator is connected. When the generator cord is not in present, a slot cover inside the panel shall maintain its waterproof integrity.

The panel shall have a NEMA L5-30P socket plug with a 8 ft long, #10 AWG, 3-wire cable routed and secured with a tie wrap inside the cabinet. A cable strain relief shall be provided for this cable.

7.2.4 Police Panel

All police panel functions shall interface through the Cabinet Control (CC) interface.

7.2.4.1 Manual Control Enable Switch

In addition to Chapter 6 requirements, the cabinet police panel shall contain a 3rd Double-Pole Double-Throw (DPDT) Toggle Power Switch. The switch shall feature a "Manual Control Enable" label. Additionally, there shall be labels for the function of each switch position. Labels shall read "AUTO" and "MANUAL".

The switch shall be used to select between two operation modes: normal operation and manual control. When the switch is in the manual control position, the toggle push button shall manually advance the traffic signals.

7.2.4.2 Interval Control Connector & Push Button

A ¼ inch three-terminal tip-ring-sleeve (TRS) receiver shall be provided in the police panel. It shall be labeled "Int. Adv.".

A waterproof manual push button shall be provided in the drawer of the cabinet. It shall have a 6ft cord and be terminated with a ¼" TRS connector. When the connector is inserted into the receiver, actuating the button shall provide the manual advance function.

CHAPTER 7-SECTION 3
CABINET ASSEMBLIES

7.3.1 General

Unless otherwise noted, the cabinet assemblies shall be completely removable from the cabinet without removing any other equipment using only a slotted or Phillips screwdriver. The following cabinet assemblies shall be treated with MIL-DTL-5541 Type II Clear Chromate or an approved Spray Wash.

<ul style="list-style-type: none">• Input Assembly	<ul style="list-style-type: none">• SB1/SB2, Clean AC, & DC Power Bus Assembly
<ul style="list-style-type: none">• Output Assembly	<ul style="list-style-type: none">• Half-depth Equipment Shelf
<ul style="list-style-type: none">• FITA	<ul style="list-style-type: none">• Full-depth Equipment Shelf
<ul style="list-style-type: none">• FOTA	<ul style="list-style-type: none">• Battery Pull-Out Drawer
<ul style="list-style-type: none">• Service Assembly	

The remaining assemblies shall have a suitable coating to prevent against corrosion.

7.3.1.1 Air Circulation

All assemblies shall allow air circulation through their top and bottom unless specifically called out otherwise.

7.3.1.2 Terminations

All assemblies shall be modular with pluggable cabling unless otherwise specified. All cabling shall be have 2 ft of slack to allow assemblies to be mounted in various positions within the rack.

7.3.1.3 Wire Raceways

Wire raceways shall be integrated as part of the cabinet, allowing for neat internal wiring. The installation of standard rack-mounted equipment shall not be inhibited by wires and cables for the full height and width of the rack.

7.3.1.4 Protection

All conductors, terminals, and parts which could be hazardous shall be protected with a suitable insulating material.

7.3.1.5 Isolation

The DC Equipment Ground shall be isolated from the AC signal ground and neutral.

7.3.1.6 Breakers

All circuit breakers shall be of magnetic or hydraulic magnetic design.

7.3.2 Output Assembly

7.3.2.1 Output Assembly (16-channel)

The Output Assembly shall provide slots on the front for:

- (1) Cabinet Monitor unit model 2212
- (1) SIU model 2218
- (8) High Density Switch Pack (HDSP) Model 2202

The Output Assembly shall provide the following on the front panel:

- Circuit breaker(s) to disconnect power to the switch-pack outputs.
- A hardware flash switch with a cover. Positions shall be labeled AUTO / FLASH
- A stop-time switch with a cover. Positions shall be labeled OFF / ON
- Momentary 24 VDC Bypass Switch
- (4) spare HDSP fuses stored in a clear plastic pouch, inside of the clear plastic pouch hanging on the door

The assembly shall have its SIU slot labeled SIU 1. Each HDSP slot shall be labeled Ch 1,2; Ch 3,4; thru Ch 15,16. All front panel components shall be labeled.

The HDSP shall interface with SIU 1 and FOTA #1.

The SIU address of the assembly shall be defined per the SIU slot labeling.

All other connections shall be on the rear of the output assembly.

AC+, AC -, & Chassis Ground shall be managed via a Molex Model 03092032 or the equivalent with a 2" pig tail connected to the rear of the assembly.

The assembly shall provide Molex Model 39281123 or the equivalent for managing the HDSP outputs to the FOTA.

A cable raceway shall be provided for the routing of cables of the assembly horizontally. The cable raceway shall not obstruct removal of connections on the rear of the output assembly.

7.3.2.2 Output Assembly (32-channel)

The Output Assembly (32-channel) shall be an optional assembly that is specified in place of the Output Assembly (16-channel). It shall meet all requirements as specified in section 7.3.2, and the following additional requirements:

The assembly shall have a maximum additional height of 5.25", totaling 10.5". It shall be placed directly below the lowest input assembly within the cabinet.

The 32-channel Output Assembly shall provide additional slots on the front for:

- (1) SIU model 2218
- (8) High Density Switch Pack (HDSP) Model 2202

The assembly's second SIU slot shall be labeled SIU 3. The additional HDSP slots shall be labeled Ch 17,18; Ch 19,20; thru Ch 31, 32.

The additional HDSPs shall interface with SIU 3 and FOTA #2

An additional cable raceway shall be provided as defined in section 7.3.2

The 32-channel Output Assembly mandates the following additions to the cabinet composition found in section 7.1.2.

Add the following:

- (1) SIU model 2218
- (9) High Density Switch Pack (HDSP) model 2202
- (1) FOTA #2

If both the Output Assembly (32-channel) and Input Assembly #3 are optioned, the Equipment Shelf (half-depth) above the Service Assembly shall be removed to accommodate. Additionally, the cabinet composition found in section 7.1.2.1 shall have its quantity of the Equipment Shelf (half-depth) and Adjustable DIN Rail decreased by 1 each.

7.3.2.3 High Density Switch Pack/ High Density Flasher Unit

The High Density Switch Pack / High Density Flasher Unit (HDSP/HDFU) shall provide 2 - 1" x ½" (W x H when viewed from the front) spaces to label the function of each of its channels.

Main HV input shall be fused with a T1AL250 fuse or the equivalent.

7.3.2.4 Cabinet Monitor Unit (CMU) Model 2212

The CMU shall be provided with an additional Datakey model LCK4000-RED serial memory key or equivalent. It shall be provided in the drawer of the cabinet.

7.3.3 Field Output Termination Assembly

7.3.3.1 Field Output Termination Assembly #1

Field Output Termination Assembly (FOTA) shall have two plugs for each of the 16 output channel functions. The first plug shall be for the red signal function, and the second plug shall be for the yellow and green signal function. Removal of any plug shall not disconnect another channel function. Each signal function shall have 2 termination points.

The cabinet shall be furnished with these Field Terminal Plugs:

- (40) screw-type (16 Red plus 4 spares; 16 Yellow & Green, plus 4 spares)
- (40) push-in-type (16 Red plus 4 spares; 16 Yellow & Green, plus 4 spares)

The plugs shall be placed in separate clear plastic packets. All field terminal plugs shall allow for termination of a minimum of (4) #12 AWG conductors for each red, yellow, and green output function.

The push-in-type Field Terminal Plug termination release levers shall be accessible without the removal of any plug.

All field terminals, flash transfer relays, and flash programming blocks shall be in the back of the cabinet and rear-facing. Additionally, the channel function(s) for each component shall be labeled.

Flash programming blocks shall use Molex Model 03062061 or the equivalent to interface with the FOTA. Flash programming blocks shall come factory-installed in the following format: Ch1-12: Red, Ch 13-16: White. 4 Red, 4 White, and 8 Yellow flash programming blocks shall be provided in a clear plastic packet in the drawer of the cabinet.

All other connections and components shall be on the inner side of the FOTA.

The Switch-pack outputs (R/Y/G) shall be individually fused for short-circuit protection. Fuses shall be accessible on the inside of the FOTA. At minimum 8 identical fuses shall be provided in a labeled bag within the door pouch. Fuses shall react equal to or faster than 0.01 seconds with a current of 20-amp.

The assembly shall provide Molex Model 39281123 or the equivalent for managing the HDSP inputs from the Output Assembly and Molex Model

39288080 or the equivalent for managing the HDFU inputs from the Service Assembly.

The assembly shall provide Molex Model 09652038 or the equivalent for monitoring the Flash Transfer Relay status.

There shall be at minimum $\frac{3}{4}$ " x $\frac{3}{4}$ " clear spacing for field labels adjacent to each Field Output for ease of identification. Field Output labeling shall be as follow: Ch 1-8 shall be labeled 1-8; Ch 9-12 shall be labeled A, B, C, D; Ch 13-16 shall be labeled P2, P4, P6, P8.

The Field Output Termination Assembly shall have an AC- (neutral) BUS with standoff insulators with a minimum of 16 wiring lugs allowing for the termination of #12 AWG conductors.

One (1) surge suppressor unit (HESCORLS Model HE103C-9 or the equivalent) shall be provided for the protection of each model 2202 Switch Pack. The surge suppressor units shall interface via a plug-and-socket design on the inside of the FOTA.

Flasher output functions for HDFU1 shall be defined as follows:

- Flasher output 1: Operates Ch1-4
- Flasher output 2: Operates Ch5-8
- Flasher output 3: Operates Ch9-12
- Flasher output 4: Operates Ch13-16

7.3.3.2 Field Output Termination Assembly #2

The Field Output Termination Assembly #2 shall be a mandated assembly when the Output Assembly (32-channel) is optioned.

The assembly shall be 19" EIA rack-mounted and have an 8.75" space reserved directly below the Field Output Termination Assembly #1 for mounting.

The assembly shall meet all the requirements defined in Section 7.3.3 with the exception of field output labeling and the flash programming blocks shall be defined as follows. Flash programming blocks shall come factory-installed in the following format: Ch 17-28: Red, Ch 29-32: White. An additional 4 Red, 4 White, and 8 Yellow flash programming blocks shall be provided in a clear plastic packet in the drawer of the cabinet.

Flasher output functions for HDFU2 shall be defined as follows:

- Flasher output 1: Operates Ch17-20
- Flasher output 2: Operates Ch21-24
- Flasher output 3: Operates Ch25-28

- Flasher output 4: Operates Ch29-32

7.3.3.3 Flash Transfer Relay

Eight (8) Flasher Transfer Relays shall be preinstalled on the FOTA(s), meeting the following requirements:

- The HDFTR shall have a hermetically sealed cover and shall be moisture-proof.
- The HDFTR shall be filled with dry nitrogen to protect contacts from corrosion and to prevent condensation.
- The HDFTR shall have a metal can cover.
- The HDFTR contacts shall be rated at 120VAC @ 10 Amp. The coil of the HDFTR shall be rated at 48VDC.
- The HDFTR shall have an LED indicator to display the contact transfer position.
- The HDFTR shall be STRUTHERS-DUNN Model 21XBHL-48VDC or the equivalent.

7.3.4 Input Assemblies

7.3.4.1 Input Assembly #1

The Input Assembly shall provide slots on the front for:

- (12) IN slots for interfacing with up to 12 sensor units
- (1) SIU model 2218

The assembly shall have its SIU slot labeled SIU 9. Each IN slot shall be labeled Ch 1,2; Ch 3,4; thru Ch 23,24.

The Input Assembly shall provide a Cabinet D Connector (CDC) interface (front-facing) within the assembly for accessing the Assembly SIU's 4 optically isolated inputs. Additionally, (4) switches shall be provided for making controller inputs through this interface. The switches shall be mounted on a toolless removable plate for easy access to the CDC interface. Each switch shall have an LED to indicate that the switch is active. These switches shall have a cover provided to prevent accidental actuation.

The opto-isolator inputs shall be labelled "Opto 1"; "Opto 2" thru "Opto 4".

All other connections shall be on the rear of the input file assembly.

AC power and ground shall be managed via a Molex Model 03092032 or the equivalent with a 2" pig tail connected to the rear of the assembly.

Phoenix Model 1936050 or the equivalent shall be used to input DC power to the assembly.

The interface between the FITA and Input File Assembly shall be Hirose Electric HIF3BA-26PA-2.54DSA or the equivalent.

The assembly shall provide an 8-position plug for specifying the SIU address of the assembly and be configured per the SIU slot labeling.

7.3.4.2 Input Assembly #2

The Input Assembly #2 shall interface with the terminations from the field input termination assembly #2 and shall meet all requirements as defined in section 7.3.4.1 with the following amendment:

- The assembly shall have its SIU slot labeled SIU 10

7.3.4.3 Input File Assembly #3

Input File Assembly #3 shall be an optional assembly that shall interface with the terminations from the Field Input Termination Assembly #3. It shall meet all requirements as defined in section 7.3.4.1 with the following amendment:

- The assembly shall have its SIU slot labeled SIU 11

The assembly shall be 19" EIA rack-mounted, have a maximum height of 5.25", and be placed directly below Input Assembly #2. The Output Assembly shall be lowered 5.25" to accommodate.

Additionally, this option mandates the following additions to the cabinet composition found in section 7.1.2.

Add the following:

- (1) SIU model 2218
- (1) FITA #3

If both the Input Assembly #3 and Output Assembly (32-channel) are optioned, the Equipment Shelf (half-depth) above the Service Assembly shall be removed to accommodate.

Additionally, the cabinet composition found in section 7.1.2.1 shall have its quantity of the Equipment Shelf (half-depth) and adjustable DIN Rail decreased by 1 each, while the cabinet composition found in section 7.1.2.2 shall only have its quantity of Equipment Shelf (half-depth) decrease by 1.

7.3.5 Field Input Termination Assemblies

7.3.5.1 Field Input Termination Assembly #1

The Field Input Termination Assembly (FITA) #1 shall provide terminations for Input File #1. It shall break out all (24) detector inputs into (12) 10-pin terminal connectors. The terminal connectors shall interface with a plug-and-socket design terminal block where each pin can accept a #14 AWG conductor. The 10-pin terminal connector shall be a front screw-locking type and shall be Phoenix Contact 1850932 or the equivalent.

The detector input terminations shall be labeled "Ch #," replacing # with the corresponding channel number.

The assembly shall organize the input terminations in a similar fashion as below:

CH1	CH3	CH5	CH7	CH9	CH11	CH13	CH15	CH17	CH19	CH21	CH23
CH2	CH4	CH6	CH8	CH10	CH12	CH14	CH16	CH18	CH20	CH22	CH24

The 10-pin terminal block pins shall be organized as follows: Pins 1,2: Ch function 1 +/-; Pins 3,4: Ch function 1 +/-; Pins 6,7: Ch function 2 +/-; Pins 8,9: Ch function 2 +/-; Pins 5,10: EQ Ground. A wiring guide shall be printed on the assembly, separate from the detector input terminations, indicating this pinout.

The termination assembly shall provide a ½" x ½" space to label the SIU address of the assembly.

The FITA's thumbscrews and all field terminals shall be in the back of the cabinet and rear-facing.

One (1) surge suppressor unit (HESCORLS Model HE6LC-6 or the equivalent) shall be provided for the protection of each IN slot. The surge suppressor units shall interface via a plug-and-socket design on the inside of the FITA.

All other connections shall be on the inner side of the FITA.

The interface between the FITA and Input Assembly shall be Hirose Electric HIF3BA-26PA-2.54DSA or the equivalent.

7.3.5.2 Field Input Termination Assembly #2

The FITA #2 shall provide terminations for Input File #2 and shall meet all requirements as defined in section 7.3.5.1

Additionally, near the last 2 10-pin input termination blocks, there shall be a label indicating that suppressors cannot be installed in suppressor termination blocks where an Emergency Vehicle Preemption (EVP) card is used.

7.3.5.3 Field Input Termination Assembly #3

The Field Input Termination Assembly #3 shall be a mandated assembly when the Input Assembly #3 is optioned.

The assembly shall be 19" EIA rack-mounted and have a 5.25" space reserved directly below the Field Input Termination Assembly #2 for mounting. The Field Output Termination Assembly(ies) shall be positioned 5.25" lower to accommodate.

The FITA #3 shall provide terminations for Input File #3 and shall meet all requirements as defined in section 7.3.5.1

7.3.6 Auxiliary Display Unit Model 2220

The Auxiliary Display Unit (ADU) Model 2220 shall be equipped in the cabinet as a 1U 19" EIA rack-mounted assembly.

7.3.7 Auxiliary Input/Output Assembly

The Auxiliary Input and Output (auxiliary I/O) Assembly shall be equipped in the Cabinet as a standalone 1U 19" EIA rack-mounted assembly. It shall have a label indicating AUXILIARY INPUT/OUTPUT ASSEMBLY. The assembly shall allow tool-free removal of the front panel, providing direct access to all connectors. The assembly cables/wires shall include a minimum of 18in of slack for full extension during the panel detachment.

The front panel rotary switch shall allow the SIU address to be configured. The module shall respond to input addresses 10, 11, 12, or 13.

The assembly shall at minimum provide the following LED indicators:

- red for inputs and outputs
- yellow for Tx and Rx communication activity
- green for Power

Each LED shall be labeled for its corresponding function.

The auxiliary I/O Assembly shall provide 24VDC inputs and outputs. The Auxiliary I/O Assembly shall include a minimum of (21) inputs, (8) outputs, and their respective connections to Logic Ground. Each input and output shall be mapped to the controller through an integrated SIU and shall be configurable. Labels shall be provided for each input/output such that they can be read when looking at the rear of the assembly upside-down. Each of the I/O points and the Logic Ground shall be terminated in removable factory-molded plug blocks for ease of connection. Plug blocks shall at minimum accept a #16 AWG conductor

Power shall be input to the assembly using Phoenix Contact Model 1777086 or the equivalent.

Communications shall be managed with a female 25-pin "D" connector with the termination and pin assignment defined according to the SB#1 / SB#2 connector.

All connections shall be rear-facing.

7.3.8 Railroad Preemption Assembly Model 2262

The railroad preemption assembly shall be an optional interchangeable ATC module that is a 1U 19" EIA rack-mount assembly. If optioned, it shall be placed directly below the auxiliary I/O assembly in the 8.75" space reserved for the controller.

The assembly shall allow tool-free removal of the front panel, providing direct access to all connectors. The assembly cables/wires shall include a minimum of 18in of slack for full extension during the panel detachment. The module shall have an integrated SIU and respond to input address 12. It shall have a label indicating RAILROAD ASSEMBLY.

Assembly shall at minimum provide LED indicators:

- red for inputs and outputs
- yellow for Tx and Rx communication activity
- green for Power

Each LED shall be labeled for its corresponding function.

Power shall be input to the assembly using Phoenix Contact Model 1777086 or the equivalent.

Communications shall be managed with a female 25-pin "D" connector with the termination and pin assignment defined according to the SB#1 / SB#2 connector details. All connections shall be rear-facing.

7.3.8.1 Railroad Inputs

The railroad preemption module shall provide a minimum of (7) opto-isolator inputs for railroad operation. The front panel shall have LED indicators and be labeled for each function. The labels shall be "ADV Pri" thru "ISL". The indicator shall be lit when the function is active.

Function	Inputs	Inputs
Advance Primary	ADV Pri	ADV DC-
Advance Secondary	ADV Sec	ADV DC-
Simultaneous Primary	SIM Pri	SIM DC-
Simultaneous Secondary	SIM Sec	SIM DC-
Advance Pedestrian Preemption	APP	APP DC-
Gate Down	GD	GD DC-
Island	ISL	ISL DC-

The field terminations shall be screw-type and be labeled as Inputs shown above. The labels shall be printed on the assembly for each input such that the text can be read when looking at the back of the railroad preemption module upside-down. All field terminal plugs shall be rear-facing, removable, and accept a #12 AWG conductor for each input.

7.3.8.2 Railroad Health Circuit

The assembly shall provide two isolated DC power circuits with outputs:

- 12VDC circuit protected by a 5x20mm, 1-amp fuse
- 24VDC circuit protected by a 5x20mm, 0.5-amp fuse

The fuses shall be accessible on the front panel. Two identical spare fuses shall be provided in a labeled, clear plastic pouch placed within the door plastic pouch.

Function	Output	Output
Health Status	HS DC+	HS DC-

The Health status LED indicators shall be provided on the front panel and shall stay lit during normal operation. The circuits shall stay high during normal cabinet operation. The circuit output shall drop when the cabinet is in flash operation or when the controller outputs a railroad fault condition.

The field terminations shall be screw-type and be labeled as the outputs shown above. The labels shall be printed on the assembly for each output such that the text can be read when looking at the back of the railroad preemption module upside-down. All field terminal plugs shall be rear-facing, removable, and accept a #12 AWG conductor for each output.

7.3.9 Service Assembly

The service assembly shall be full-width EIA 19-inch rack-mounted, utilizing a maximum of 3U. The Service Assembly shall have the following on the front panel:

- (1) Duplex GFCI 120VAC receptacle including:
 - Type-A USB charging port capable of a minimum of 10 watts at 5VDC
 - Type-C USB charging port capable of a minimum of 10 watts at 5VDC
- (2) OUT slots configured for HDFU operation mode of 32 output channels
- Circuit breakers
- (8) HDFU Fuses, 2A fast blow 5x20mm for the protection of the (2) HDFUs
 - Shall be mounted in a Wurth Elektronik Model 696122003002 Fuse Holder and a Wurth Elektronik Model 696122003001 Clip Cover or the equivalent
- (4) spare HDFU fuses
 - Shall be mounted in a Wurth Elektronik Model 696122003002 Fuse Holder and a Wurth Elektronik Model 696122003001 Clip Cover or the equivalent
 - Shall have a label indicating "Spare HDFU Fuses"

The service assembly shall have the following on the rear at minimum:

- (7) Service assembly terminals (non-pluggable, screw-type): shall be rear-facing and accept at minimum #4 AWG service conductors. The terminals shall be used for service power-in, BBS, and UBS.
- (1) Clean power NEMA 6-15R receptacle
- (1) Clean power NEMA 5-15R receptacle
- (1) Raw power NEMA 5-15R receptacle
- Screw-type terminal block(s) for distribution of AC power through the termination of (2) 2-conductor 14 AWG cable
- SB#3 Interface
- Molex Model 39288080 or the equivalent for managing the HDFU outputs to the FOTA

The HDFU outputs should have cabling provided for interfacing with 2 FOTA.

The service assembly shall provide a multi-stage, high-energy suppressor line filter with warning/failure LED indicators. It shall be the HESCO RLS model HE1750 ALT or the equivalent.

All components of the service assembly shall be labeled.

The Flasher unit fuses shall be rated to react equal to or faster than 0.01 seconds with a current of 20A.

Flasher unit breaker shall not react faster than the flasher unit fuse.

7.3.10 DC Power Supply

The DC Power Supply shall be a Model 2216-24 Cabinet Power Supply.

The DC power supply shall input AC power using a C14 receptacle. It shall be connected to the clean power bus with a cable terminated with a C13 connector and 5-15P NEMA plug. The C13/C14 plug and receptacle shall meet IEC 60320 standards.

The DC power supply shall output power via a 6-position factory molded plug and socket. The output shall be connected to the DC power bus.

The DC power supply indicators, fuses, and plugs shall be labeled with their corresponding function.

7.3.11 SB1/SB2, Clean AC, & DC Power Bus Assembly

The SB1/SB2, Clean AC, & DC Power Bus Assembly (Bus Assembly) shall provide the following interfaces in the back of the cabinet and rear-facing:

- (8) DB25 connectors to interconnect the SB1/SB2 communications
- (1) Phoenix Model 1777112 or the equivalent to input DC power to the DC power bus
- (7) Phoenix Model 1825734 or the equivalent to output DC power to cabinet assemblies
- (8) NEMA 5-15R receptacles

Additionally, the following interfaces shall be provided at minimum in the back of the cabinet and front-facing, see A7-15 for details:

- (4) Phoenix Model 1825734 to output DC power to auxiliary cabinet components

It shall include a termination circuit at the end of the connections (SB1/SB2) to prevent radio frequency signal reflection.

The conductors for the DC voltages shall support a minimum of 5 Amps.

The conductors for the AC voltages shall support a minimum of 15 Amps.

The Assembly shall be mounted in the EIA rails. The assembly shall be hinged to provide access to the back of the assembly. Cutouts shall be provided on the assembly for the routing of cables inside the rack and maintain the assembly's ability to hinge. The assembly shall have slotted cable raceways and covers for

toolless routing of serial & DC power cables. The assembly shall have tie-off points for routing the AC power cables.

The clean power bus shall be supplied with clean AC power via a NEMA 6-15P plug connected to a 6-15R receptacle located on the service assembly.

The assembly shall receive DC power from the DC power supply.

Labels shall be provided that indicate the function of each terminal block.

7.3.12 Managed AC Power Strip

The AC Power Strip shall be a 1U EIA 19-inch rackmount assembly with a maximum depth of 7 inches. It shall have a minimum of 8 NEMA 5-15R receptacles that are outward-facing. It shall be rated for minimum 12 Amps continuous within the temperature range of -30 to 165°F. It shall be managed at a minimum via an RJ45 jack and feature ON/OFF control of a minimum of 8 receptacles. It shall input power from the Service Assembly's clean power NEMA 5-15R receptacle.

7.3.13 Power Over Ethernet Switch

The Power Over Ethernet (POE) Switch shall be a 1U EIA 19-inch rackmount assembly with a maximum depth of 18". It shall be mounted with adapter brackets to set the assembly back into the rack a depth of 0.75 - 1.25". The cooling design shall be fanless.

Power inputs shall be as follows:

- Primary PoE power input with terminations for minimum (1) 12 AWG conductors
- Redundant/Secondary PoE power input with terminations for minimum (1) 12 AWG conductors, that are separate from the Primary PoE power input
- Switch Unit shall be powered via PoE power inputs or standalone AC input with terminations for minimum 14 AWG conductors

It shall have a minimum of 16 RJ45 ports capable of operating at minimum 10/100/1000 Mbps, with a minimum of 12 being POE capable. It shall also have a minimum of 4 SFP ports capable of operating at minimum 1/10G.

It shall have a power budget of 600 Watts minimum.

The switch must be compliant with the following standards at minimum:

- IEEE 802.3 10BASE-T, 802.3u 100BASE-TX/100BASE-FX, 802.3ab 1000BASE-T
- IEEE 802.3af type 1, 802.3at/bt type 2/3, and 802.3bt type 4: for PD devices
- IEEE 802.3x: for packet management

- IEEE 802.3z 1000BASE-SX/1000BASE-LX
- IEEE 802.3ad: for Link aggregation
- IEEE 802.1D: for STP
- IEEE 802.1p: for prioritizing network traffic
- IEEE 802.1Q: for VLAN support
- IEEE 802.1s: for MSTP
- IEEE 802.1w: for RSTP
- IEEE 802.1X PNAC
- IEEE 802.1ab: for support of LLDP
- IEEE 1588v2: for PTP
- IETF RFC 2131: DHCP
- IETF RFC 2819: RMON
- IETF RFC 5798: providing routing redundancy
- SNIA SFF-8431: SFP+ support
- SNIA SFF-8472: provides monitoring support for SFP ports using DOM/DMM

The following additional features shall be supported at minimum:

- Layer 2/3 Routing
- SNMP v1/v2c/v3
- IP Packet Routing via:
 - Static Routing
 - RIP v1/v2
 - OSPF v2
- Port Mirroring
- Remote authentication through RADIUS and TACACS+
- Feature to ping PoE devices, and if the device does not respond after a minimum of 3 pings, the switch will power-cycle the port.
- All ports shall be individually disabled or enabled, administratively
- SSH for interfacing with the CLI
- Web management interface featuring TLS and HTTPS for web security
- Configuration backup support
- PoE port priority: Specify which ports to prioritize power to when load exceeds power supply output

7.3.14 Power Over Ethernet Power Supplies

The POE Power Supply shall supply power to the switch's main power input with conductors rated for 20 amps minimum. The output and input terminations shall

at minimum, allow a 12 AWG and 16 AWG conductor to be terminated, respectively. It shall be supplied power from the SB1/SB2, Clean AC, & DC Power Bus Assembly. The cooling design shall be fanless.

An identical Power Over Ethernet Power Supply shall be included for redundancy, meeting the requirements for the specified power supply. The redundant power supply output shall be terminated to provisions for a redundant power input on the network switch. The redundant power supply shall be supplied power from the SB1/SB2, Clean AC, & DC Power Bus Assembly

7.3.14.1 Power Over Ethernet Power Supply - Standard

The POE Power supply shall be a DIN rail mount assembly with maximum dimensions of 6", 3.5", 6.5" (HxWxD) when mounted vertically. It shall be mounted on the adjustable DIN Rail assembly and centered vertically within the available space. It shall have a minimum continuous output of 360 watts at 54VDC nominal within the temperature range of -13 to 158°F.

An identical Power Over Ethernet Power Supply shall be included for redundancy meeting the requirements defined above. The redundant power supply output shall be terminated to provisions for a redundant power supply on the network switch. It shall be supplied power from the SB1/SB2, Clean AC, & DC Power Bus Assembly.

7.3.14.2 Power Over Ethernet Power Supply - High-Power

The Power Over Ethernet Power Supply – High-Power shall be an optional assembly that is specified in place of the Power Over Ethernet Power Supply - Standard.

The Power Over Ethernet Power Supply High-Power shall be a DIN rail mount assembly with maximum dimensions of 6", 5.5", 6.5" (HxWxD) when mounted vertically. It shall be mounted on the adjustable DIN Rail assembly and centered vertically within the available space. It shall have a minimum continuous output of 600 watts at 54VDC.

7.3.15 Drawer Shelf

The drawer shall be 1U and 13 inches deep. The drawer shall extend out 12 inches minimum. The cover shall be powder coated black. The cover shall be liftable to a minimum of 45°. It shall be front-mounted and supported horizontally at the sides with removable brackets. It shall be removable with only the removal of the controller unit from the cabinet.

7.3.16 Equipment Shelf (Half-Depth)

The half-depth equipment shelf shall be a 1U rackmount assembly with air vents. The equipment shelf shall meet the specifications as listed in A7-9.

7.3.17 Battery Pull-Out Drawer

The battery pull-out tray shall be AWI & BHMA certified and shall:

- Hold up to 250 lbs.
- Ball bearing slide, Accuride 7957 heavy duty or equivalent
- 18in extension

7.3.17.1 Battery Mat

The tray surface shall have absorbent, acid neutralizing mat made of polypropylene needle punch felt. The mat shall be batterymat part 1001536 or the equivalent. The mat shall be secured to the tray surface by adhesion.

7.3.18 Adjustable DIN Rail Assembly

The EIA 19-inch rack mount adjustable DIN rail assembly shall be 1U, have a maximum depth of 10.75", and be capable of holding 35 lbs minimum. The assembly shall have an adjustable travel range that has a minimum movement range of 6 to 10 inches inboard from the rack face. The DIN rail shall be Top hat, type TS35 with perforation. The adjustable mechanism shall be either latches or captive screws to lock in place.

CHAPTER 7-SECTION 4

CABINET COMPONENTS

7.4 Cabinet Components

The cabinet shall be furnished with the following components.

7.4.1 Datakey Programmer

The cabinet shall be provided with a USB programmer unit and a 3-foot-long male USB type A to male type B cable for programming the Datakey used in the Cabinet Monitor Unit.

1 Datakey Programmer shall be provided for each 10 cabinets ordered.

7.4.2 Ethernet Cable

The cabinet shall be provided with an 8-foot-long ethernet cable for connecting the Cabinet Monitor Unit to the Network Switch

7.4.3 Fuses, Thermostat, and Fans

The fuses and thermostats shall not obstruct access to any cabinet assemblies or rack. They shall be located in the rear of the cabinet, accessible between the rack and cabinet housing. Fuses and thermostat shall have direct access for replacement and adjustments.

The cabinet shall be equipped with 24VDC powered electric fans with ball, fluid dynamic, or magnetic bearings and a capacity of at least 100 cubic feet of free air delivery per minute. The fan shall be mounted within the housing and vented. The Model 352ATC housing shall be equipped with two fans and the Model 362ATC housing shall be equipped with four fans. The thermostat and fan covers shall meet Chapter 6 requirements.

7.4.4 Circuit Breaker Switch Guard

All circuit breakers shall have switch covers to prevent unintentional disconnection.

7.4.5 Cabinet Lights

The cabinet shall have LED fixtures mounted on each mounting cage in front of each door. The lights shall be 24VDC controlled by door switch and with a manual switch. The lighting shall be directed toward the cabinets components to minimize glare. The color temperature shall be Daylight. The light shall be 300–500 lumens per linear foot.

7.4.6 Antenna Bracket

Two antenna brackets shall be installed and meet the specifications as listed in A7-10.

CHAPTER 7-SECTION 5

CABINET WIRING

7.5.1 Cabinet Wiring Diagram

7.5.1.1 Diagrams/Drawings Supply

Four sets of nonfading (comparable to Xerox 2080) cabinet wiring diagrams and drawing sheets shall be supplied with each cabinet. They shall identify all circuits in such a manner as to be readily interpreted. The cabinet drawing sheets shall show the equipment layout and connections.

The diagram and drawing sheets shall be placed in a heavy-duty side-opening clear plastic pouch and hung on two hooks (not to be above the lock assembly) on the front cabinet door.

7.5.1.2 Pouch

A pouch shall be provided to hold the Cabinet Wiring and Drawing Sheets, USB Data Drive, and Cabinet Keys. The pouch shall be of such design and material that it provides adequate storage and access to the wiring diagram sheets and cabinet manuals. The pouch shall be of size and strength to easily hold the documents and keys without tearing.

7.5.1.3 USB Data Drive

The cabinet manual, drawing sheets, and wiring diagram shall be provided on a USB drive placed in the pouch, together with the wiring diagram and drawing sheets.

7.5.2 Conductors

7.5.2.1 General

All conductors, except those that can be readily traced, shall be labeled. Labels attached to each end of the conductor shall identify the destination of the other end of the conductor.

7.5.3 Terminal Blocks

Terminal blocks shall be labeled with the exclusion of those used on the front of the FOTA & FITA.

CHAPTER 7-SECTION 6
ELECTRICAL TERMONOLOGY

7.6.1 Glossary of Terms

A	Amperes
AC	Alternating Current
AC+	120 Volts AC, 60 hertz ungrounded power source
AC-	120 Volts AC, 60 hertz grounded return to the power source
ADU	Auxiliary Display Unit
Aux. I/O	Auxiliary Input/Output
ADV	Advance
APP	Advance Pedestrian Preemption
ASSY	Assembly
ATC	Advanced Transportation Controller
AUX	Auxiliary
AWG	American Wire Gage
bps	bits per second
CCC	Cabinet C Connector
Ch	Channel
CLI	Command Line Interface
Controller Unit	That portion of the controller assembly devoted to the operational control of the logic decisions programmed into the assembly
DC	Direct Current
DHCP	Dynamic Host Configuration Protocol
DIN	Deutsches Institut fur Normung (German Institute for Standardization)
DMM	Digital Diagnostics & Monitoring
DOM	Digital Optical Monitoring
EG	Equipment Ground
EIA	Electronic Industries Association
FIT	Field Input Terminal

FITA	Field Input Termination Assembly
FOTA	Field Output Termination Assembly
FU	Flasher Unit
HDFU	High-Density Flasher Unit
HDSP	High-Density Switch Pack
HV	High Voltage
IEC	International Electrotechnical Commission
IEEE	Institute of Electrical and Electronics Engineers
IETF	Internet Engineering Task Force
IFA	Input File Assembly
IN	Input
ITE	Institute of Transportation Engineers
LED	Light Emitting Diode
LLDP	Link Layer Discovery Protocol
LV	Low Voltage
NAC	Network Access Control
NEMA	National Electrical Manufactures Association
OFA	Output File Assembly
OPTO	Optical-Coupled Inputs
PD	Power Delivery
POE	Power Over Ethernet
PTP	Precision Time Protocol
RMON	Remote Monitoring
RMU	Remote Monitoring Unit
RFC	Request for Comments
SB#	Serial Bus number
SEC	Secondary
SFP	Small Form-factor Pluggable
SIM	Simultaneous
SIU	Serial Interface Unit
SNIA	Storage Networking Industry Association

SSH	Secure Shell
TB	Terminal Block
TRS	tip-ring-sleeve
USB	Universal Serial Bus
VAC	Voltage Alternating Current
VDC	Voltage Direct Current
VLAN	Virtual Local Area Network
VRRP	Virtual Router Redundancy Protocol
X	Number Value

CABINET HOUSING 1C

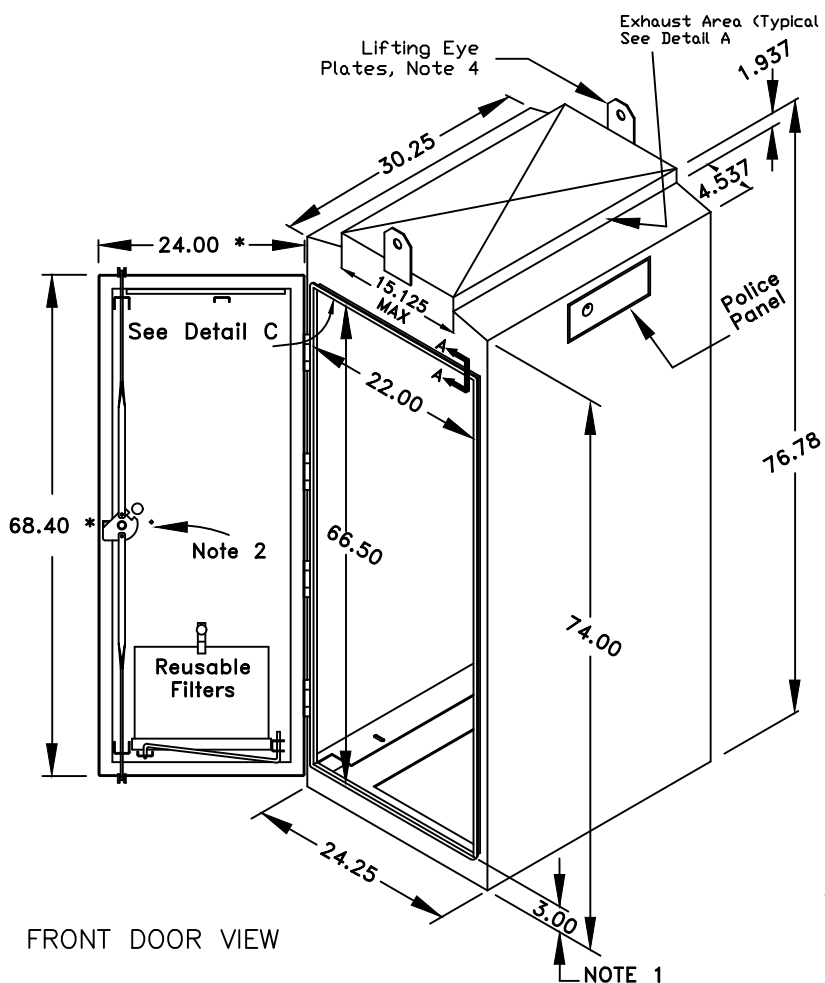

FRONT DOOR VIEW

DETAIL A
CABINET HOUSING 1C
VENTILATION EXHAUST DETAIL

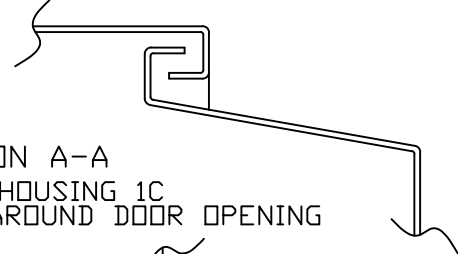

SECTION A-A
CABINET HOUSING 1C
FLANGE AROUND DOOR OPENING

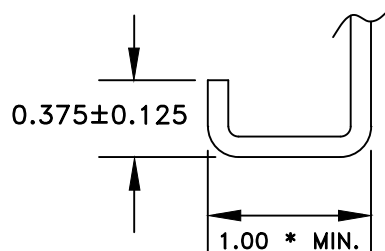

* TOLERANCE +0.0625, -0

CABINET HOUSING 1C BOTTOM DETAIL

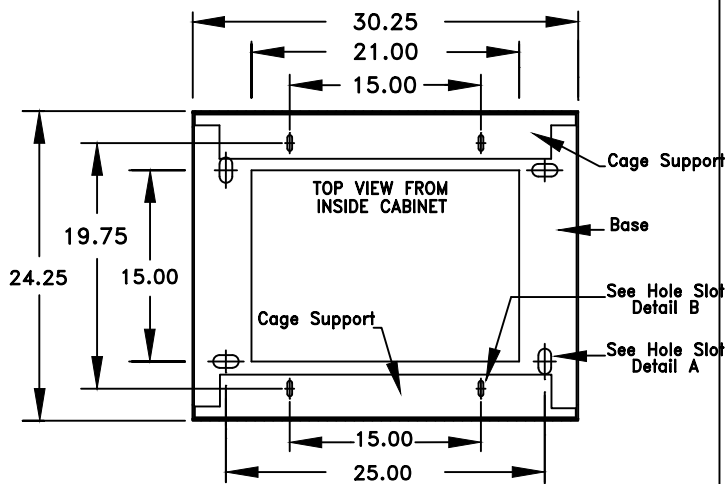

HOLE SLOT DETAIL

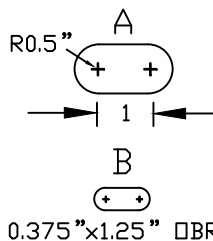

DETAIL C

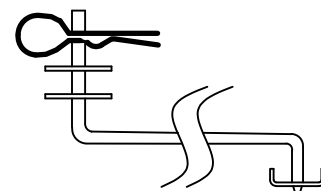

NOTE:

1. Cabinet base to door opening.
2. The locks & handles shall be on right side of the front door & the left side of the rear door (viewed externally)
3. Upper and lower catches must hold the door open at multiple positions
4. Lifting eye plates shall rotate without the use of tools.
5. All dimensions shown are in inches.

NOTE: ALL HOLE PATTERNS CENTERED ON CABINET BOTTOMS.

TITLE: CABINET HOUSING #1C DETAILS SHEET 1 OF 2	
	NO SCALE
TEES 2026	A7-1

CAGE SUPPORT DETAIL

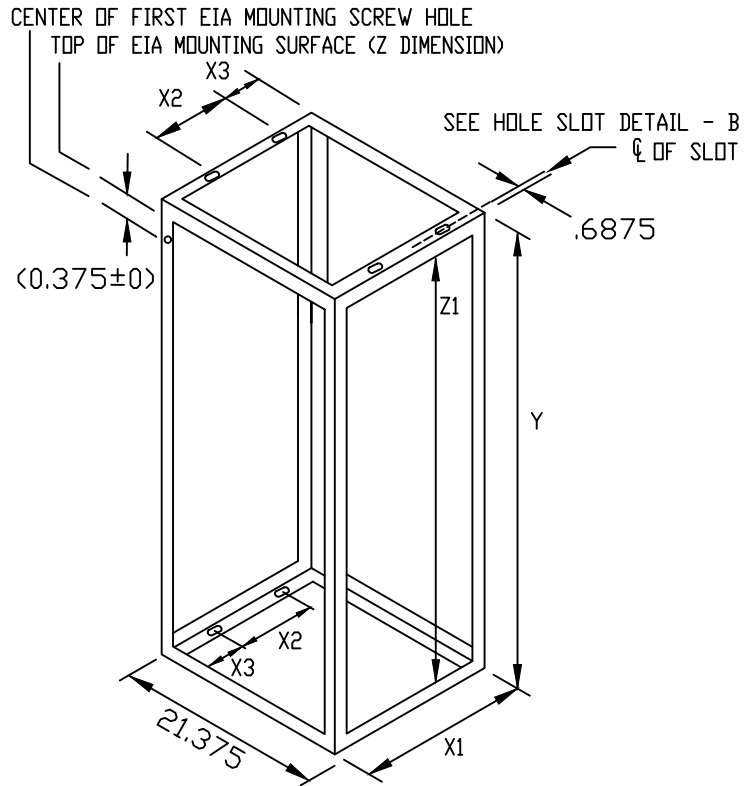

FRONT VIEW

CABINET CAGE DIMENSIONS

CAGE #3

X1	21.375
X2	15.00
X3	3.188
Y	66.00
Z1	64.50

NOTE:

1. For additional Cage Support details, see Cabinet Housing 1B in Chapter 6.
2. All dimensions shown are in inches

TITLE:	CABINET HOUSING #1C, CAGE#3 DETAILS SHEET 2 OF 2	
		NO SCALE
TEES 2026		A7-2

CABINET HOUSING #3
GENERATOR PANEL

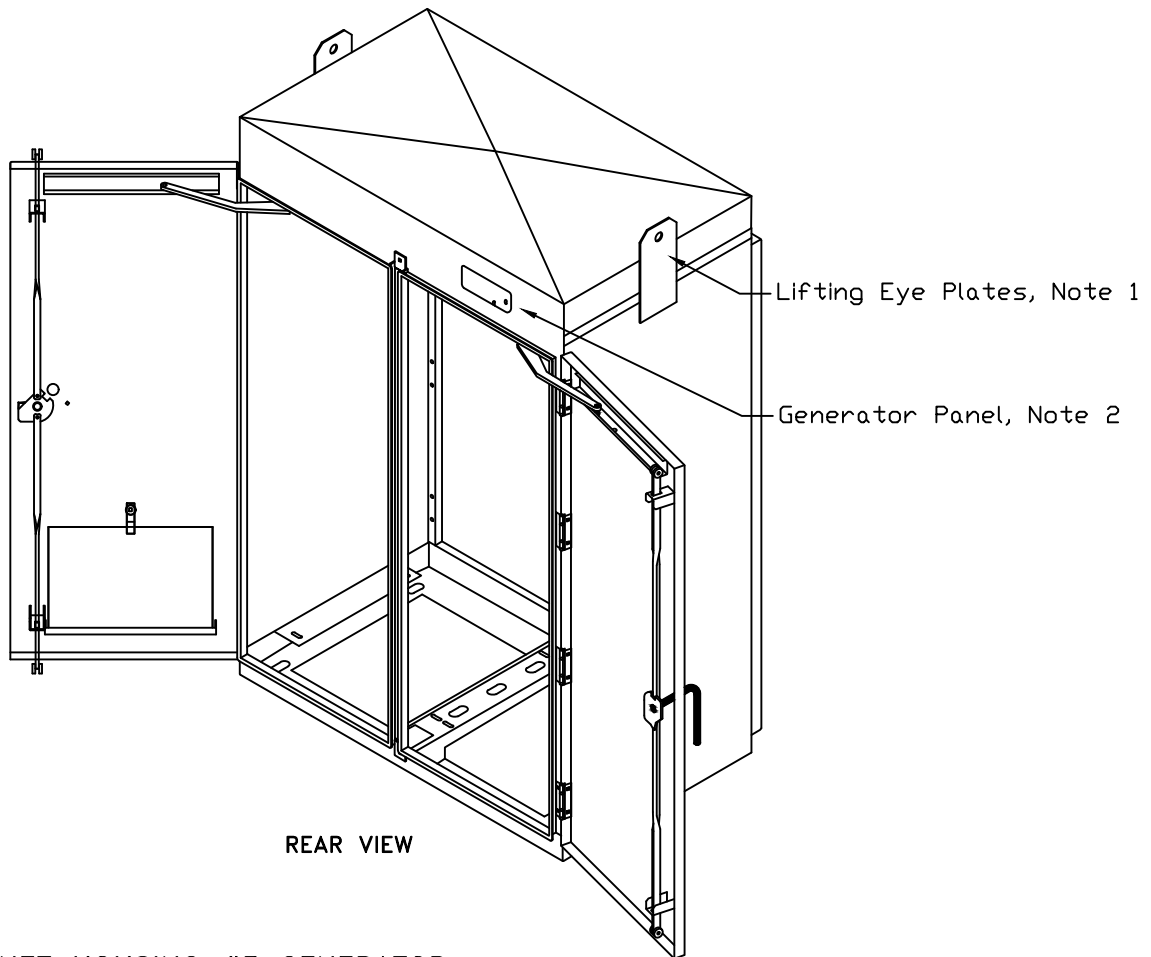

CABINET HOUSING #3 GENERATOR
PANEL DETAIL

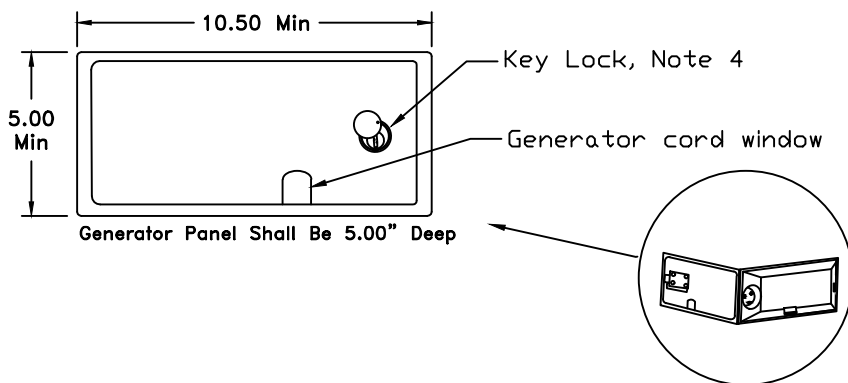

NOTE:

1. Lifting eye plates shall rotate without the use of tools.
2. The Generator panel shall be on the Rack 2 side.
3. The generator panel door shall be hinged on the left and key lock on the right side.
4. The key lock, Corbin 2 Type or equal.
5. The generator plug socket shall be on the left of the panel.
6. All dimensions shown are in inches.

TITLE: CABINET HOUSING #3 GENERATOR PLUG DETAILS	
	NO SCALE
TEES 2026	A7-3

MODEL 352ATC

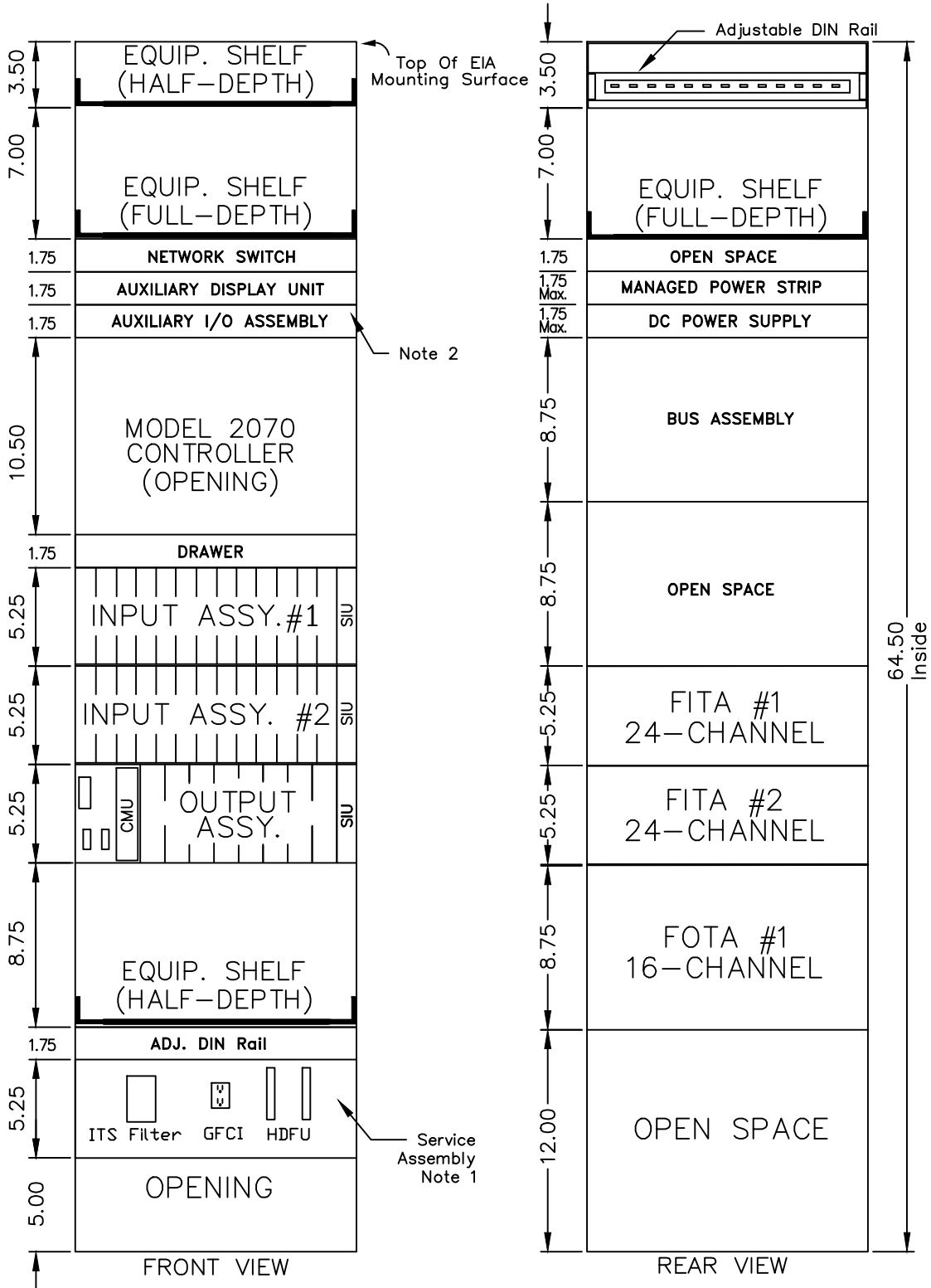

NOTE:

1. Service Assembly rack-mounted, all service conductors connections in the rear.
2. Auxiliary I/O Assembly removable from hinges.
3. All FITA, FOTA and bus assembly panels shall be hinged.
4. All switches shall have a switch guard.
5. All dimensions shown are in inches.

TITLE:	
MODEL 352ATC CABINET EQUIPMENT MOUNTING DETAILS	
	NO SCALE
TEES 2026	A7-4

MODEL 362ATC CABINET FRONT VIEW

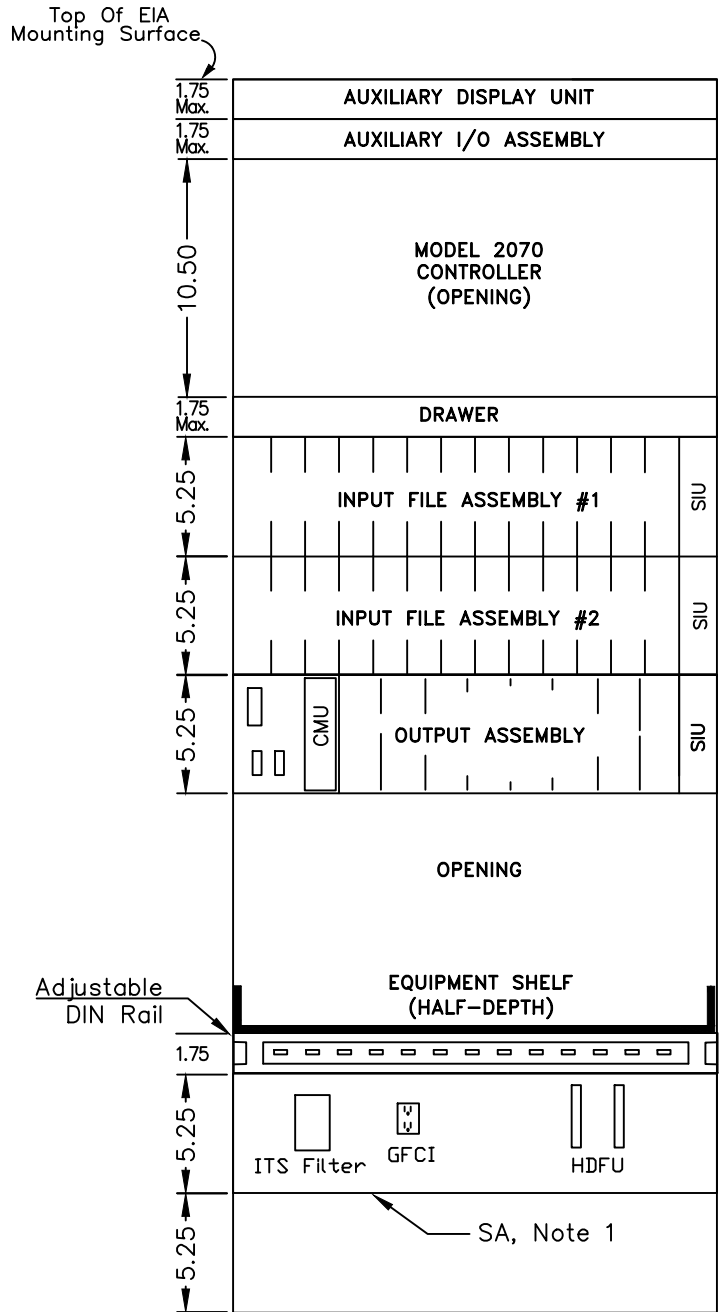
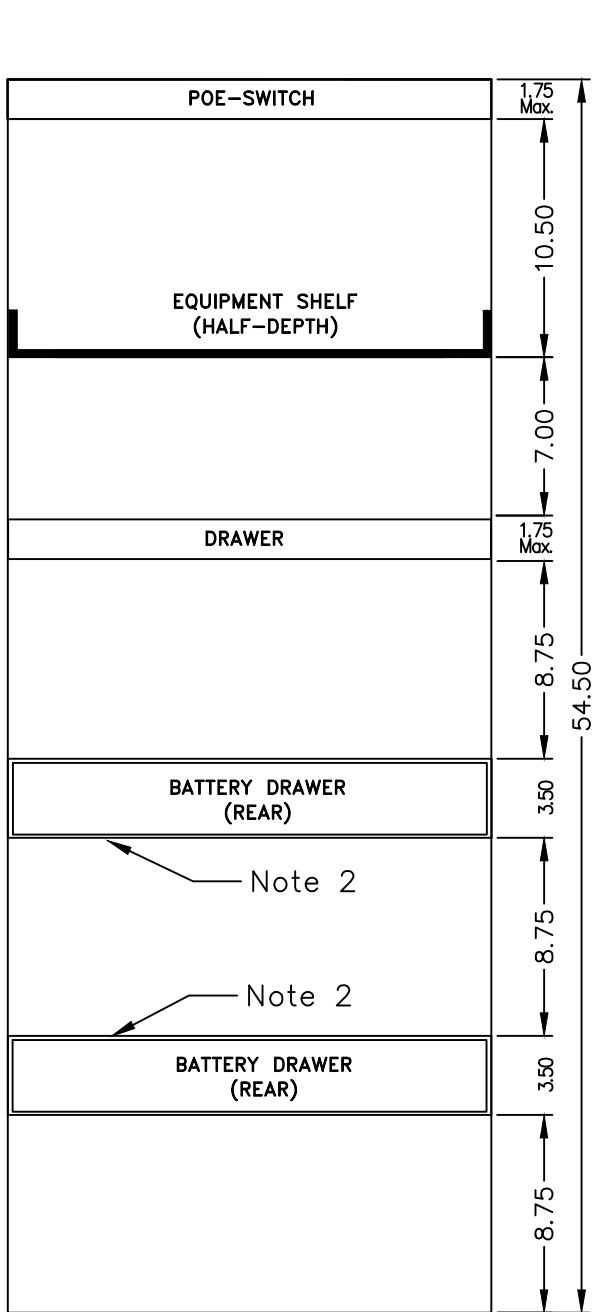

NOTE:

1. Service Assembly shall be rack-mounted, all service conductors connections in the rear.
2. Battery Drawer pulls-out at rear of cabinet.
3. Auxiliary I/O Assembly removable from hinges.
4. All switches shall have a switch guard.
5. All dimensions shown are in inches.

TITLE:	MODEL 362ATC CABINET EQUIPMENT MOUNTING DETAILS SHEET 1 OF 2
	NO SCALE
TEES 2026	A7-5

MODEL 362ATC CABINET REAR VIEW

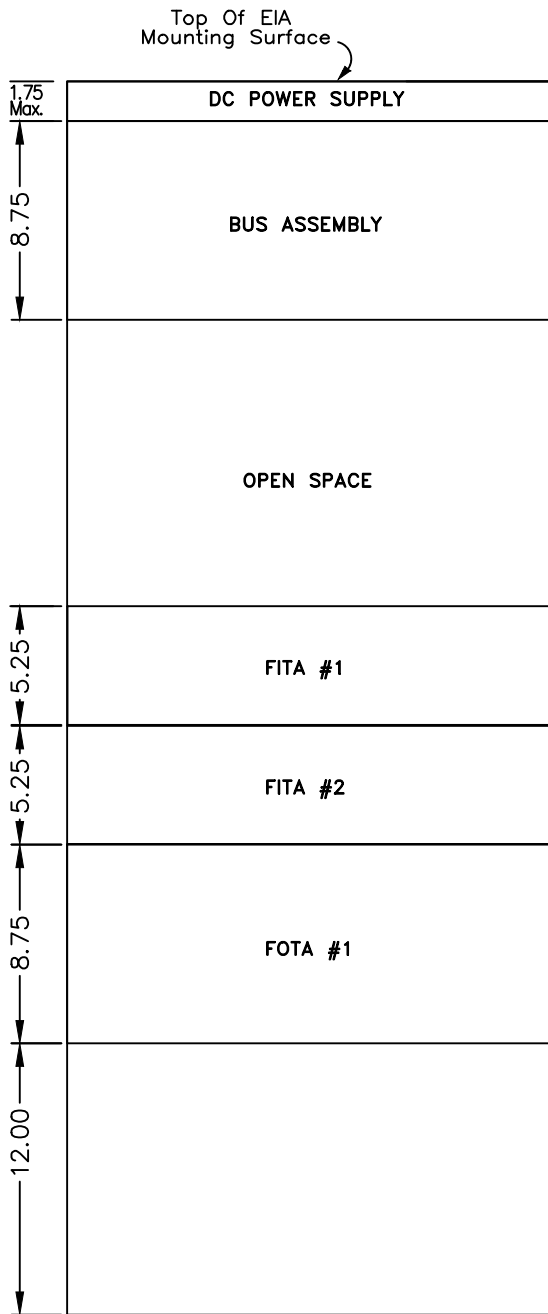

(Rack 1)

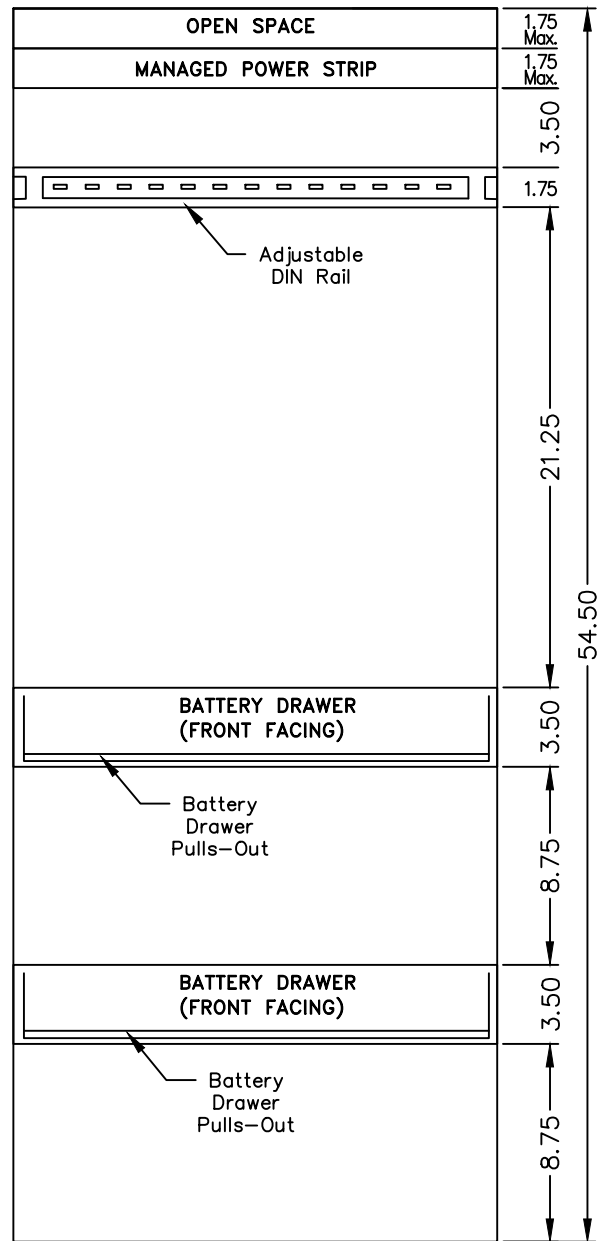

(Rack 2)

NOTE:

1. All FITA, FOTA and bus assembly panels shall be hinged.
2. All dimensions shown are in inches.

TITLE:	MODEL 362ATC CABINET EQUIPMENT MOUNTING DETAILS SHEET 2 OF 2
	NO SCALE
TEES 2026	A7-6

BATTERY PULL-OUT DRAWER

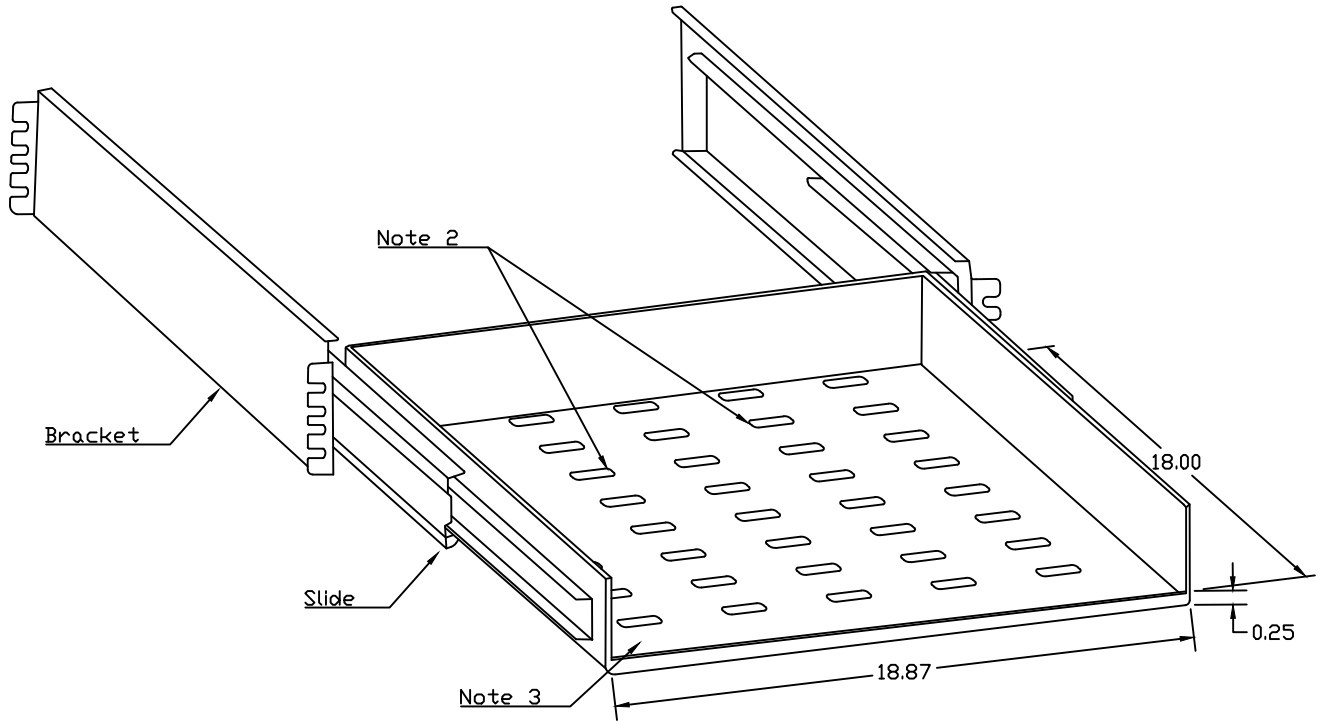

NOTE:

1. For rack details see cabinet housing #1B and #3.
2. Air vents slots.
3. Battery mat surface top,
4. All dimensions shown are in inches.

TITLE:

BATTERY PULL-OUT DRAWER DETAILS
SHEET 1 OF 1

NO SCALE

TEES 2026

A7-7

ATC DRAWER SHELF ASSEMBLY

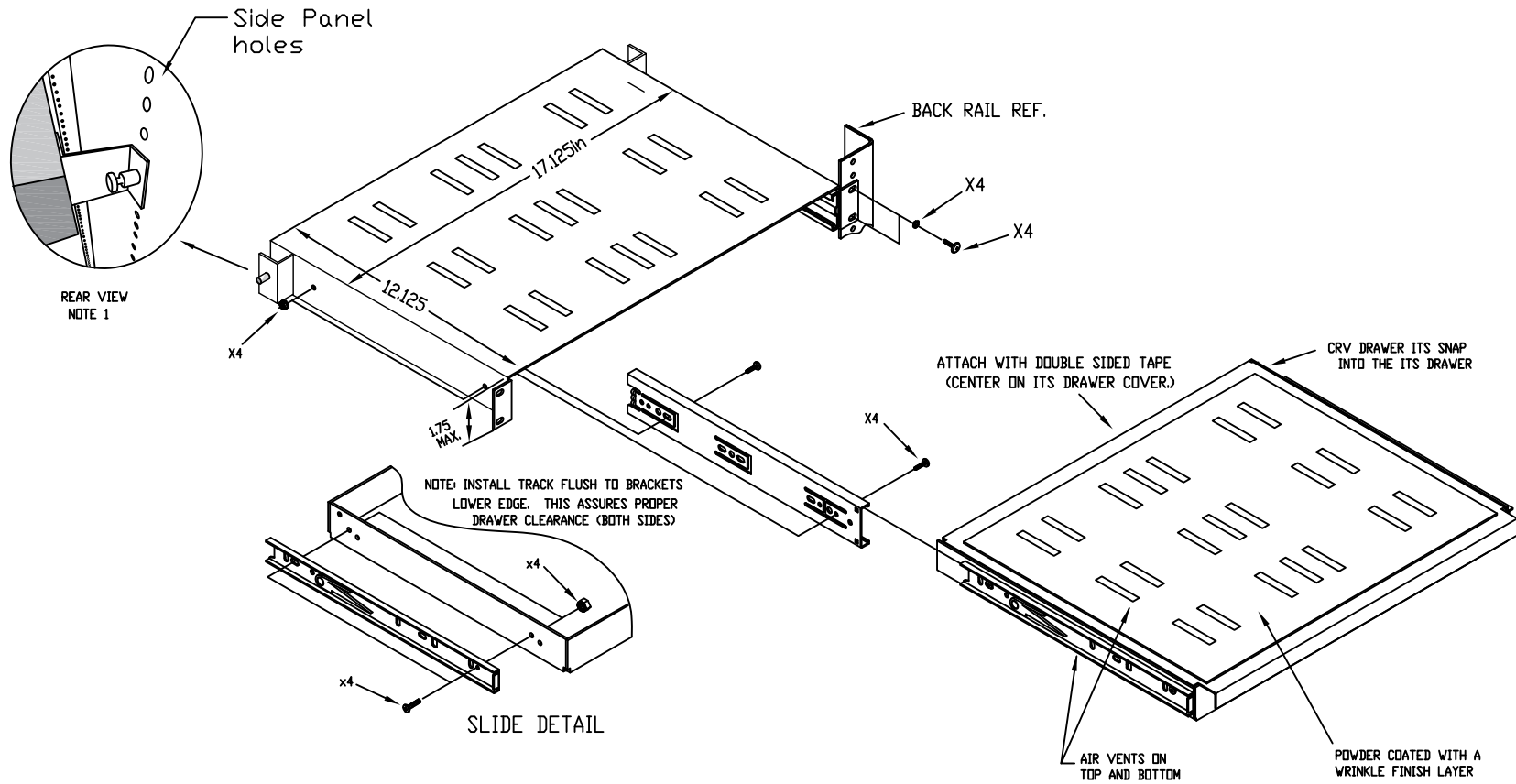

NOTES:

1. Spring loaded pin shall latch into the side panel hole.
2. All dimensions shown are in inches.

TITLE: ATC DRAWER SHELF ASSEMBLY DETAIL	
	NO SCALE
TEES 2026	A7-8

EQUIPMENT SHELF
HALF-DEPTH

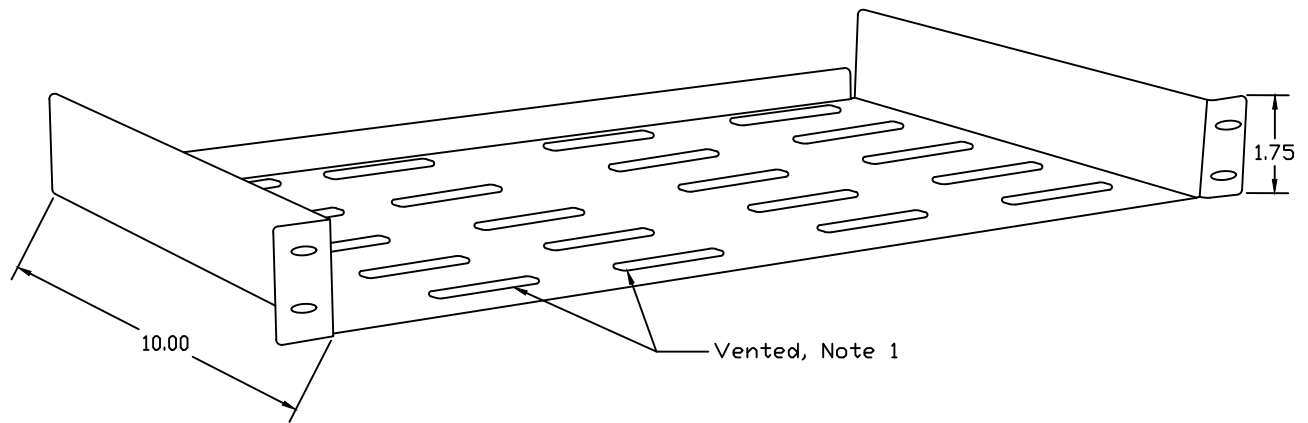

- NOTE:
1. Air vent slots.
2. All dimensions shown are in inches.

TITLE:	
EQUIPMENT SHELF HALF-DEPTH DETAILS	
	NO SCALE
TEES 2026	A7-9

MODEL 352ATC & 362ATC
ANTENNA BRACKET DETAILS
(CONTROLLER RACK)

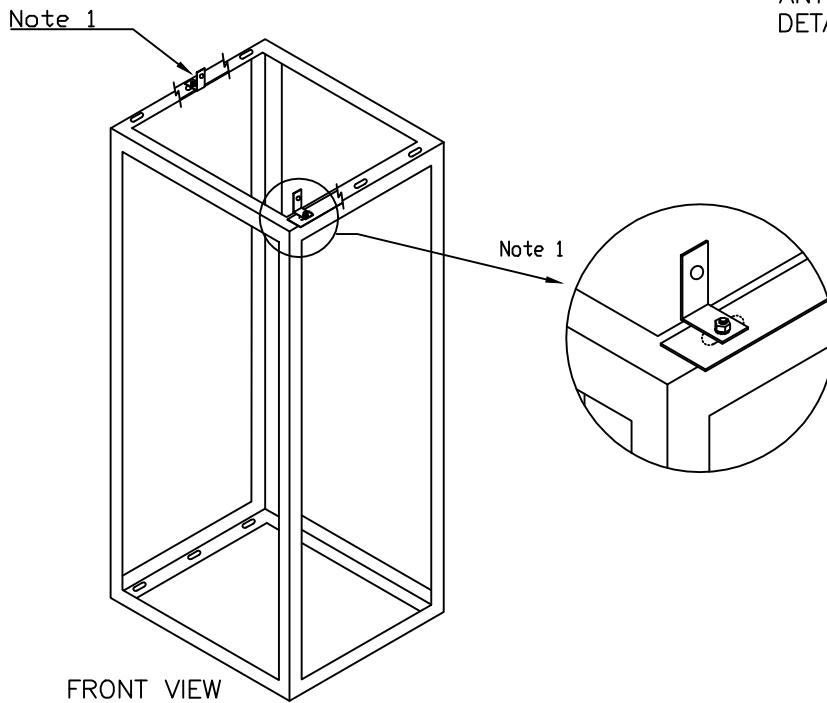
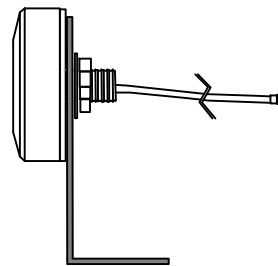
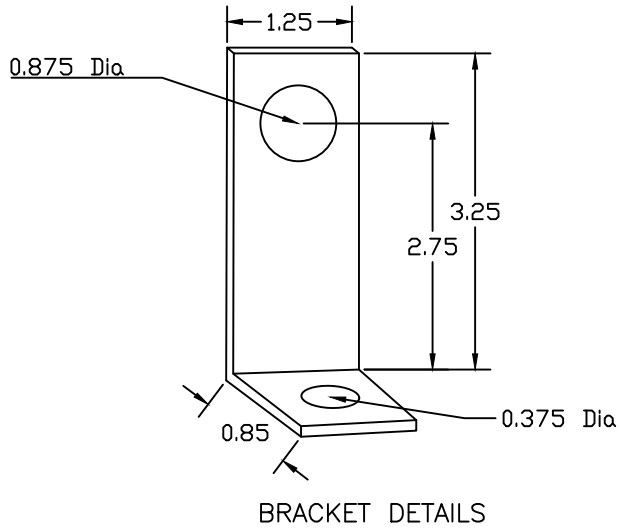

NOTE:

1. Install bracket only.
2. Shall be #16 AWG or greater.
3. All dimensions shown are in inches

TITLE:	MODEL 352ATC & 362ATC RACK #1 ANTENNA BRACKET DETAILS	
		NO SCALE
TEES 2026		A7-10

MODEL 352ATC
SIDE PANEL

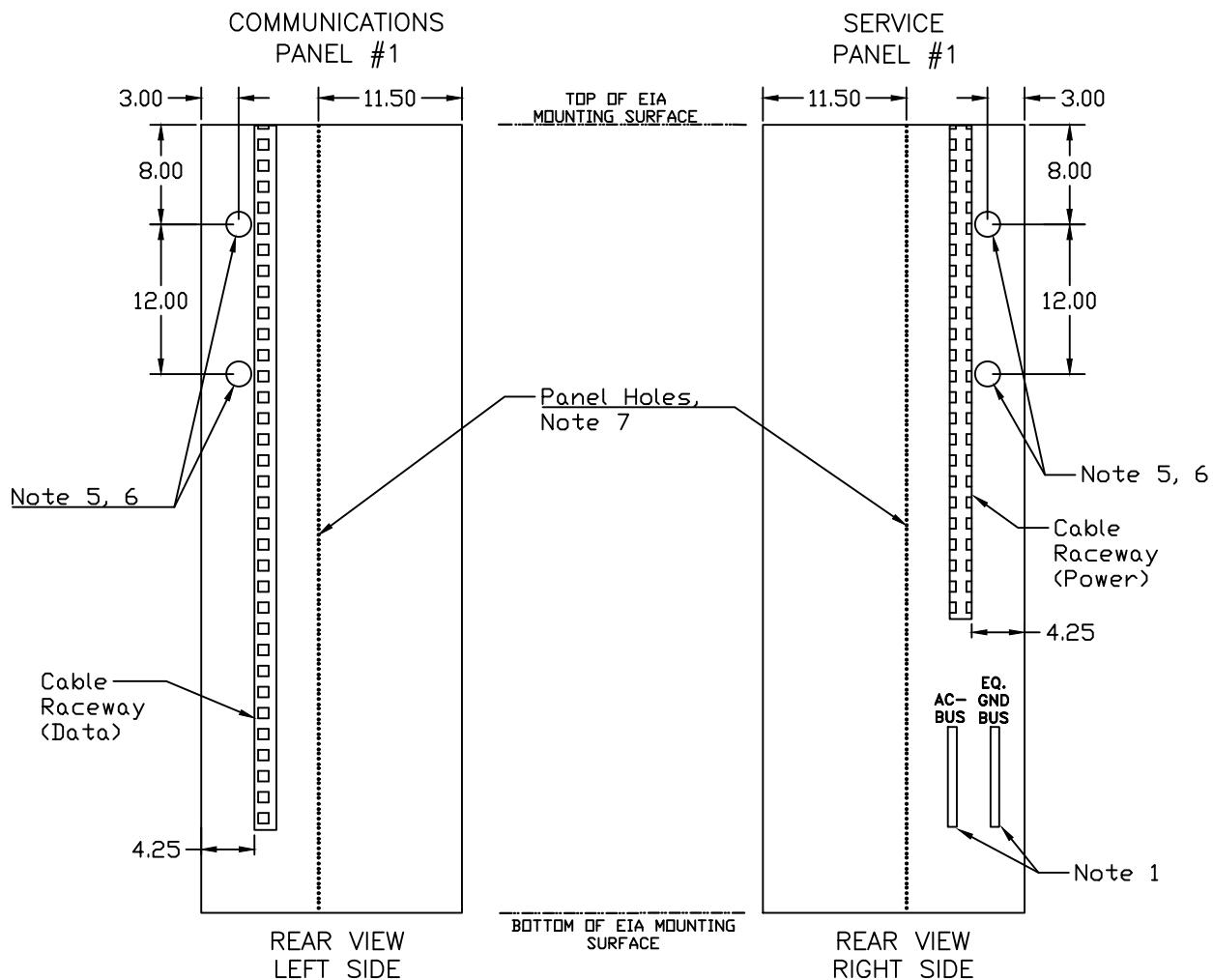

NOTES:

1. 10 terminal (#8 wire) minimum copper bus.
2. AC and Ground bus shall be unobstructed, and accessible from the rear, bottom of the cabinet.
3. Cable Raceway shall be slotted and provide a removable cover.
4. Cable Raceways, minimum (1" x 3") to maximum (1.3" x 4") [HXW]. Shall run lengthwise from above the AC/EQ. bus to the top of the EIA mounting surface, such that assembly wiring is routed through it.
5. All 2.0 inch dia holes shall be deburred and have smooth surface.
6. Install (1) standard black neoprene grommet in each hole.
7. EIA hole pattern, 1/4 inch Dia.
8. All dimensions shown are in inches.

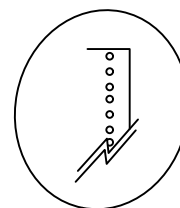

PANEL HOLES,
Note 7

TITLE: Model 352ATC SIDE PANEL DETAILS	
	NO SCALE
TEES 2026	A7-11

MODEL 362ATC SIDE PANEL

COMMUNICATIONS
PANEL #1

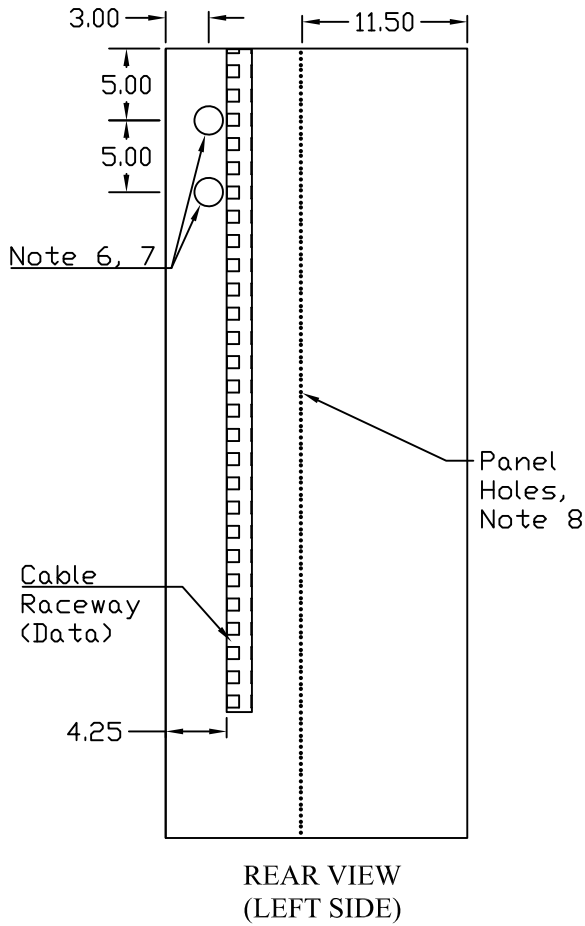

SERVICE
PANEL #1

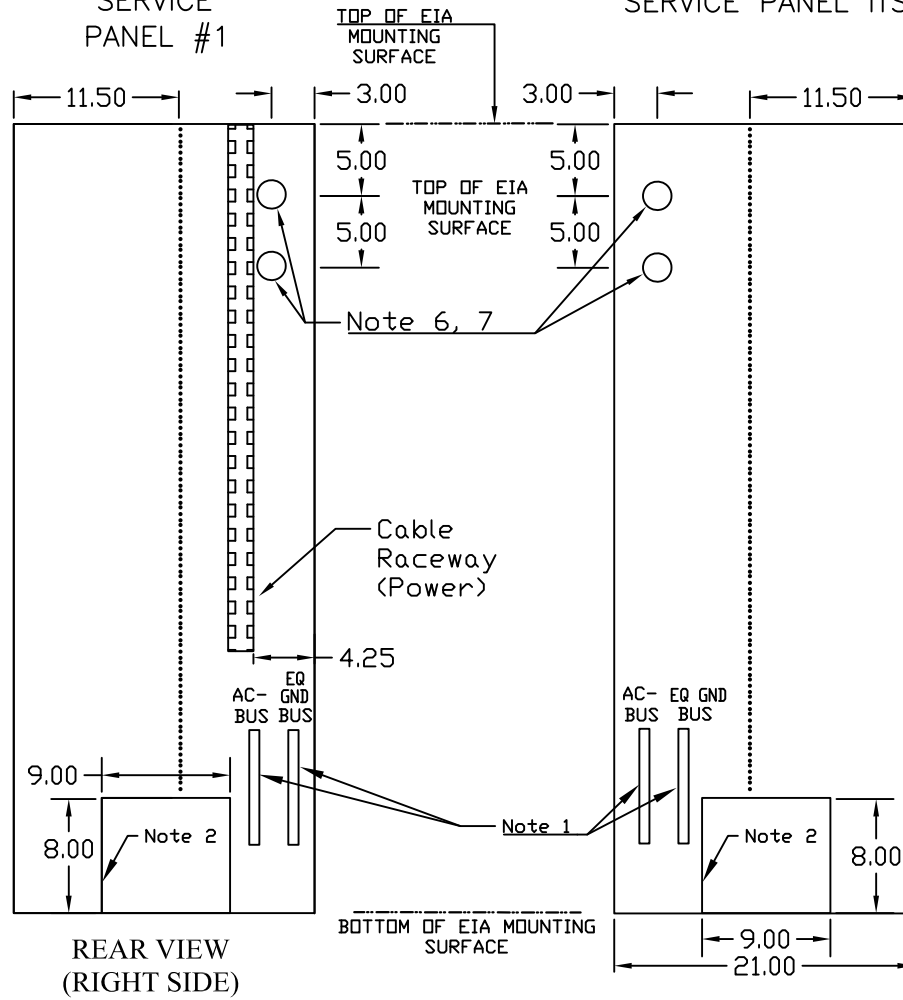

SERVICE PANEL ITS

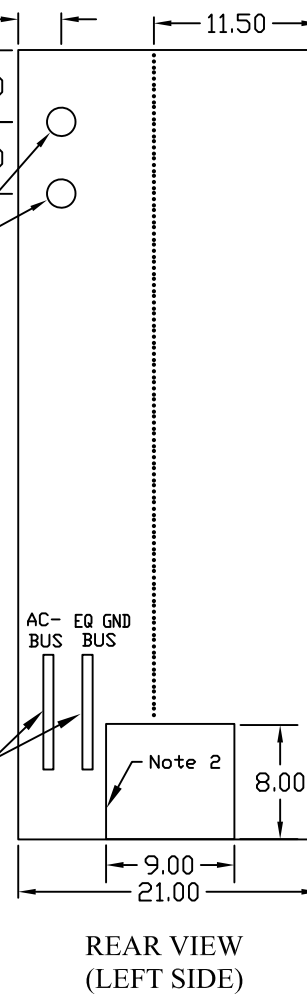

ITS PANEL

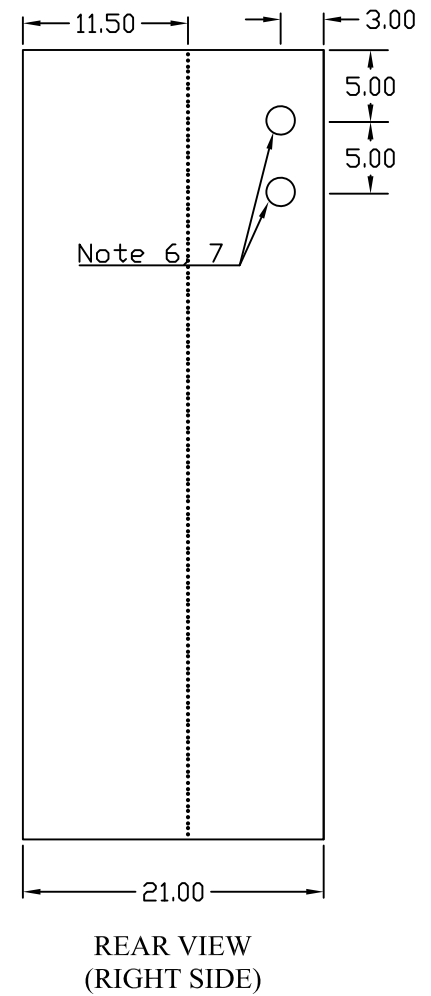

NOTES:

1. 10 terminal (#8 wire) minimum copper bus.
2. Cutout for passing conductors.
3. AC and Ground bus shall be unobstructed, and accessible from the rear, bottom of the cabinet.
4. Cable Raceway shall be slotted and provide a removable cover.
5. Cable Raceways, minimum (1"x3") to maximum (1.3"x4") [HXW]. Shall run lengthwise from above the AC/EQ. bus to the top of the EIA mounting surface, such that assembly wiring is routed through it.
6. All 2.0 inch dia holes shall be deburred and have smooth surface.
7. Install (1) standard black neoprene grommet in each hole.
8. EIA hole pattern, 1/4 inch Dia, See A7-10 for details.
9. All dimensions shown are in inches.

TITLE:	MODEL 362ATC SIDE PANEL DETAIL	
		NO SCALE
TEES 2026		A7-12

ATC CABINET FAN AND THERMOSTAT DETAILS

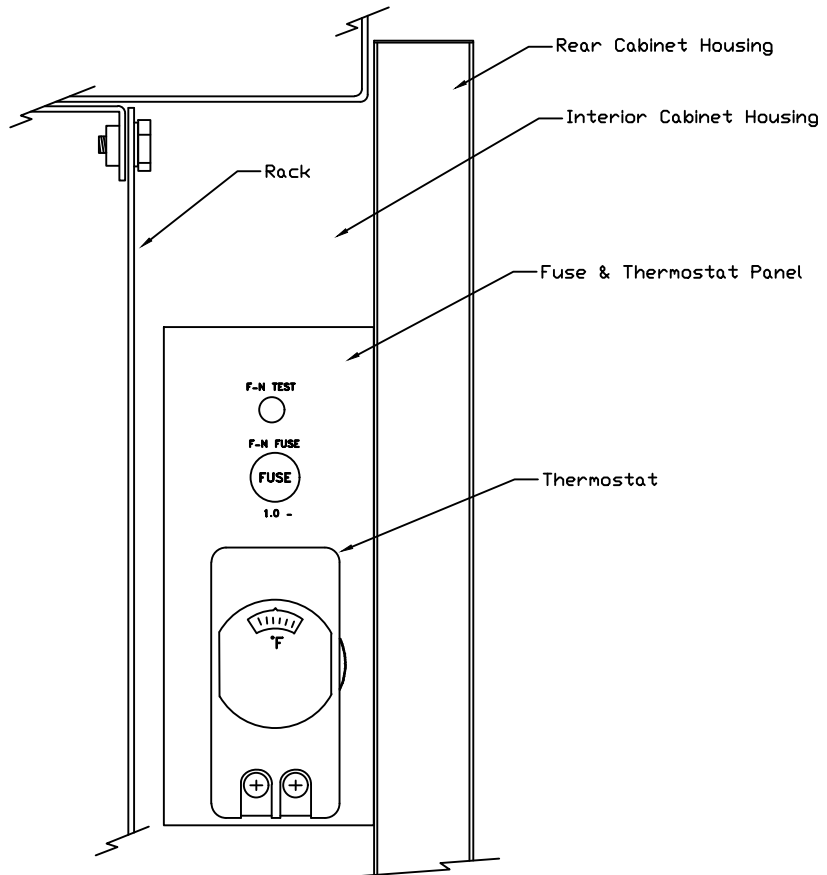
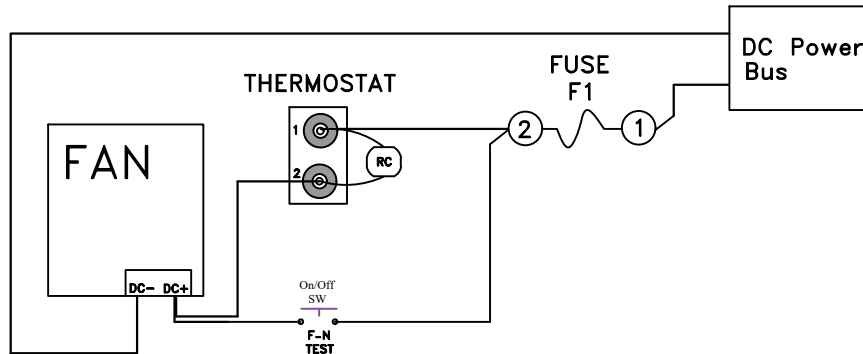

352ATC THERMOSTAT MOUNTING DETAILS

- NOTE:
1. Model 362-TC shall have 2 of the above.
 2. Model 362-TC shall have thermostat mounted above the rack.
 3. -All dimensions are in inches

TITLE: F-N AND THERMOSTAT DETAILS	
	NO SCALE
TEES 2026	A7-13

ATC CABINET LED DC LIGHTING HOUSING

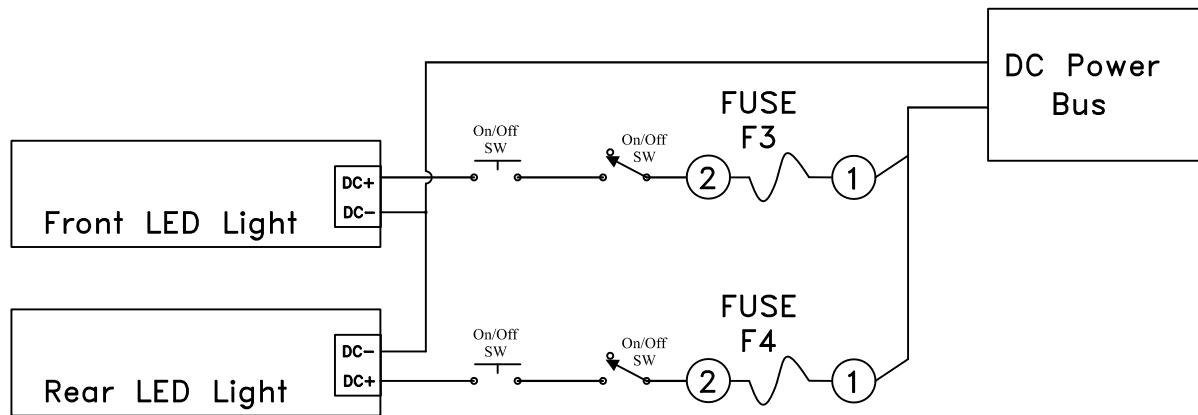

LED LIGHTING DETAILS

NOTE:

1. LED Lights for 352ATC and 362ATC cabinets
2. The LED switch shall be labeled cabinet lights.
3. All dimensions are in inches

TITLE:

LED DC LIGHTING
HOUSING

NO SCALE

TEES 2026

A7-14

SB1/SB2, Clean AC, & Power Bus Assembly – DC Power Detail

DC POWER IN

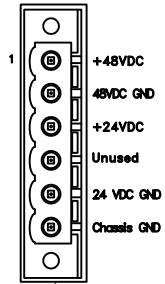

Note 1

DC POWER OUT

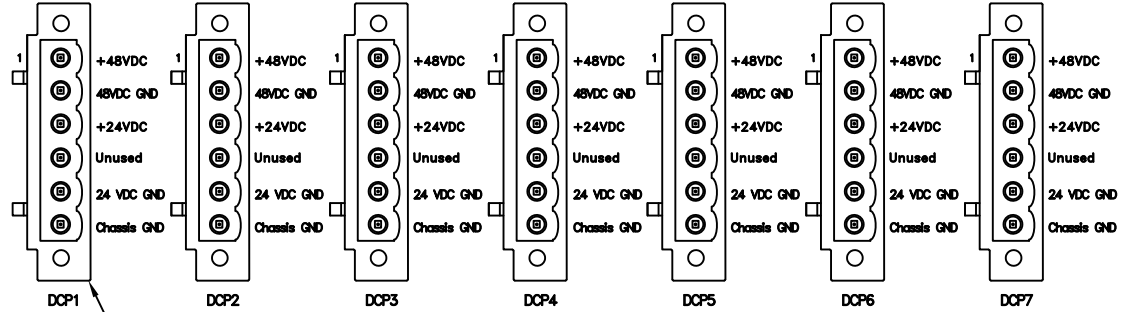

Note 2

(Front of Assembly)

DC POWER OUT

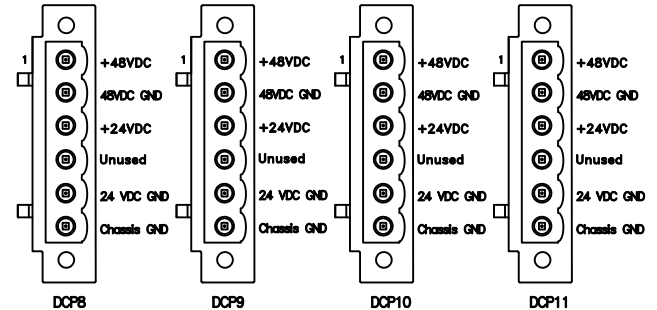

(Rear of Assembly)

NOTES:

1. Phoenix Contact Model 1777112 or equivalent.
2. Phoenix Contact Model 1825734 or equivalent.
3. All dimensions shown are in inches.

TITLE: SB1/SB2, Clean AC, & Power Bus Assembly – DC Power Detail

NO SCALE

TEES 2026

A7-15

ATC FIELD OUTPUT TERMINATION ASSEMBLY (1-16 CHANNEL)

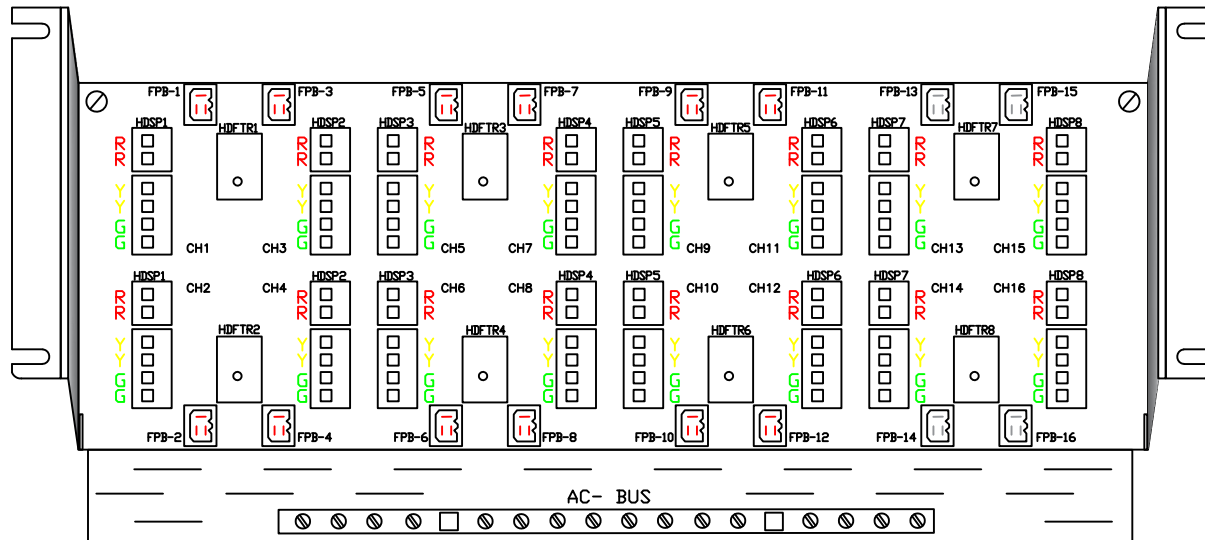

FRONT VIEW

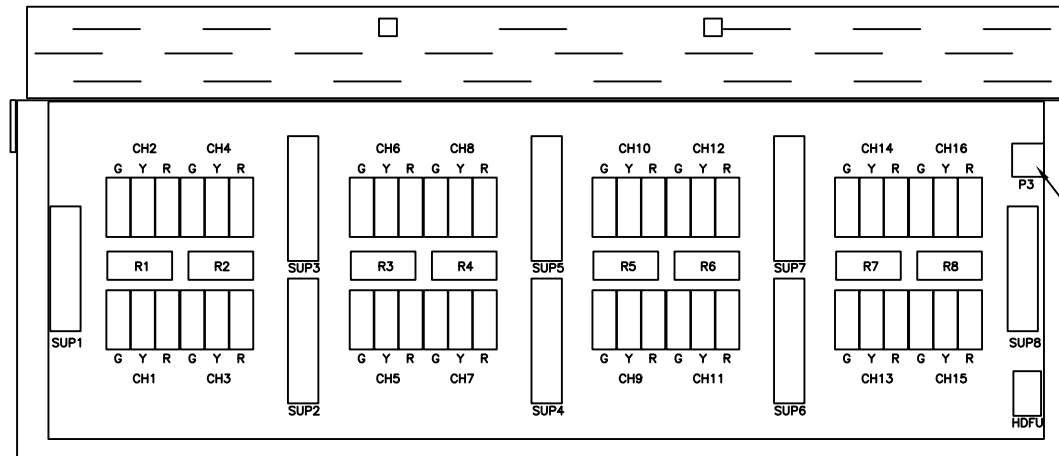

REAR (INSIDE) VIEW

Note 1

NOTES:

1. Flash Transfer Relay Status connector P3.
2. HDFU connector, Molex Model 39288080 or equivalent.
3. R1 thru R8 connectors, Molex Model 39281123 or equivalent.
4. HDSP = High Density Switch Pack, FOTA = Field Output Termination Assembly, SA = Service Assembly, HDFU = High Density Flasher Unit, CKTS = Circuits, FTR = Flash Transfer Relay, OA = Output Assembly, SUP = Suppressor, CH = Channel, G = green, Y = yellow, R = red

TITLE: ATC FIELD OUTPUT TERMINATION ASSEMBLY (1-16 CH)	
	ND SCALE
TEES 2026	A7-16

ATC HDSP, HDFU, FTR CONNECTION PINOUTS

HDSP CONNECTOR PINOUT

PIN	R1 FUNCTION	R2 FUNCTION	R3 FUNCTION	R4 FUNCTION	R5 FUNCTION	R6 FUNCTION	R7 FUNCTION	R8 FUNCTION
1	CH1R out	CH3R out	CH5R out	CH7R out	CH9R out	CH11R out	CH13R out	CH15R out
2	CH1Y out	CH3Y out	CH5Y out	CH7Y out	CH9Y out	CH11Y out	CH13Y out	CH15Y out
3	CH1G out	CH3G out	CH5G out	CH7G out	CH9G out	CH11G out	CH13G out	CH15G out
4	CH1R sen	CH3R sen	CH5R sen	CH7R sen	CH9R sen	CH11R sen	CH13R sen	CH15R sen
5	CH1Y sen	CH3Y sen	CH5Y sen	CH7Y sen	CH9Y sen	CH11Y sen	CH13Y sen	CH15Y sen
6	CH1G sen	CH3G sen	CH5G sen	CH7G sen	CH9G sen	CH11G sen	CH13G sen	CH15G sen
7	CH2R out	CH4R out	CH6R out	CH8R out	CH10R out	CH12R out	CH14R out	CH16R out
8	CH2Y out	CH4Y out	CH6Y out	CH8Y out	CH10Y out	CH12Y out	CH14Y out	CH16Y out
9	CH2G out	CH4G out	CH6G out	CH8G out	CH10G out	CH12G out	CH14G out	CH16G out
10	CH2R sen	CH4R sen	CH6R sen	CH8R sen	CH10R sen	CH12R sen	CH14R sen	CH16R sen
11	CH2Y sen	CH4Y sen	CH6Y sen	CH8Y sen	CH10Y sen	CH12Y sen	CH14Y sen	CH16Y sen
12	CH2G sen	CH4G sen	CH6G sen	CH8G sen	CH10G sen	CH12G sen	CH14G sen	CH16G sen

See Note 1

FTR - FOTA	
PIN	FUNCTION
1	DC- Bus
2	FTR coil
3	EQ gnd

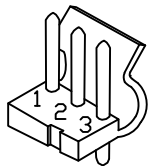

3 CKTS, Note 1

HDFU	
PIN	FUNCTION
1	2-2 sen
2	2-1 sen
3	1-2 sen
4	1-1 sen
5	1-1 fused
6	1-2 fused
7	2-1 fused
8	2-2 fused

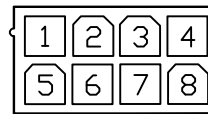

8 CKTS, Note 2

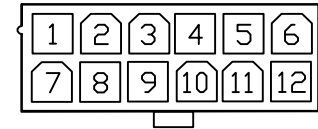

12 CKTS, Note 3

NOTES:

1. Flash Transfer Relay Status connector (P3 connector) between OA & FOTA
Molex Model 09652038 or equivalent.
2. SA to FOTA connectors, Molex Model 39288080 or equivalent.
3. FOTA to OA connectors, Molex Model 39281123 or equivalent.

TITLE:	ATC HDSP, HDFU, FTR CONNECTION PINOUTS
	NO SCALE
TEES 2026	A7-17

INPUT/OUTPUT ASSEMBLY POWER CONNECTOR DETAILS

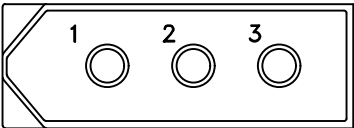

INPUT

PIN 1 - AC+
 PIN 2 - AC-
 PIN 3 - GND

OUTPUT

PIN 1 - AC+
 PIN 2 - AC-
 PIN 3 - GND

NOTE:
 1. Phoenix Contact model 03092032 or equivalent.
 2. Used with Molex Model 42477 or 42478 terminals or equivalent

TITLE: INPUT/OUTPUT ASSEMBLY POWER CONNECTOR DETAILS	
	NO SCALE
TEES 2026	A7-18

FIELD INPUT LETTERED SIDE

INPUT SLOT PINOUT

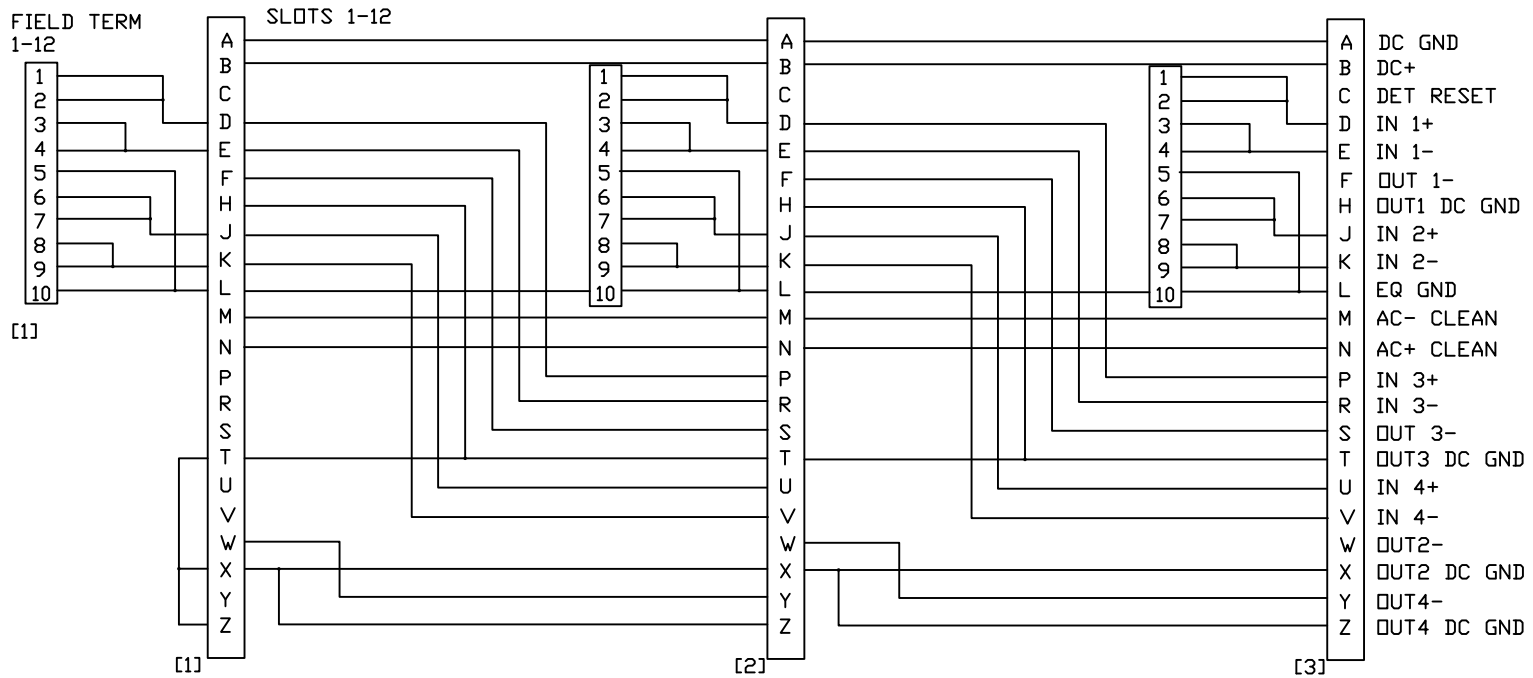

FIELD INPUT CONNECTOR NUMBERED SIDE

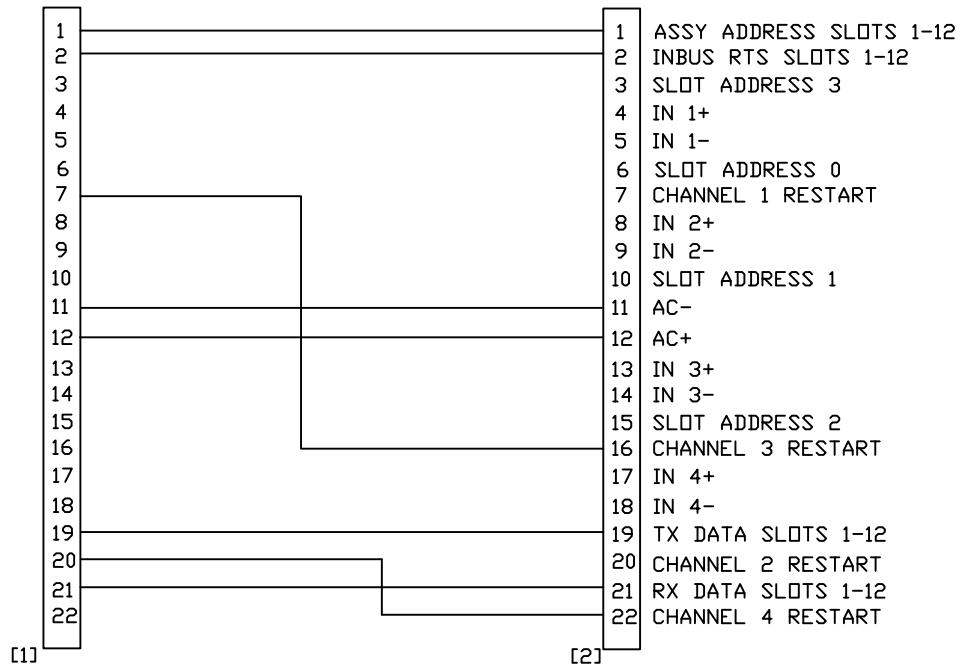

NOTES:

TITLE:	
IN SLOT PINOUT	
	NO SCALE
TEES 2026	A7-19

SIU ADDRESS SELECTOR JUMPER

SIU INPUT ASSY ADDRESS				
	SIU INPUT ASSY	ADDRESS		ADDR PLUG BINARY
*	INPUT ASSEMBLY 1	1-2	7-8	1001
*	INPUT ASSEMBLY 2	1-2	5-6	1010
	INPUT ASSEMBLY 3	1-2	5-6 7-8	1011
	INPUT ASSEMBLY 4	1-2	3-4	1100
	INPUT ASSEMBLY 5	1-2	3-4 7-8	1101

ADC DETAIL INPUT 1				
	PIN #	FUNCTION	PIN #	FUNCTION
*	1	ADDRESS 3	2	DC GROUND
	3	ADDRESS 2	4	DC GROUND
	5	ADDRESS 1	6	DC GROUND
*	7	ADDRESS 0	8	DC GROUND

ADC DETAIL INPUT 2				
	PIN #	FUNCTION	PIN #	FUNCTION
*	1	ADDRESS 3	2	DC GROUND
	3	ADDRESS 2	4	DC GROUND
*	5	ADDRESS 1	6	DC GROUND
	7	ADDRESS 0	8	DC GROUND

NOTES:

1. Jumper settings are ground true.
Install jumper for logic 1.
* = Used configurations in this cabinet.
2. ADC = Address Connector
SIU = Serial Interface Unit
ASSY = Assembly

TITLE:	ATC SIU ADDRESS SELECTOR JUMPER
	NO SCALE
TEES 2026	A7-20

DCP INPUT/OUTPUT ASSEMBLIES PIN-OUT

DCP INPUT/OUTPUT ASSLY	
PIN	FUNCTION
1	+48VDC
2	48VDC GND
3	+24VDC
4	Unused
5	24VDC GND
6	EQ GND

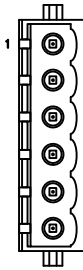

NOTES:

1. DCP = Direct Current Power.
2. Phoenix Contact Model 1936050 or Equivalent.
3. Assembly uses pins as required.

TITLE: DCP INPUT/OUT ASSEMBLIES PIN-OUT	
	NO SCALE
TEES 2026	A7-21

INPUT ASSEMBLY TO FITA DETAILS

IA TO FITA J1 CABLE CONNECTIONS

PIN#	IA J1	FITA J1
1	IN 1+	IN 1+
2	IN 2+	IN 2+
3	IN 3+	IN 3+
4	IN 4+	IN 4+
5	IN 5+	IN 5+
6	IN 6+	IN 6+
7	IN 7+	IN 7+
8	IN 8+	IN 8+
9	IN 9+	IN 9+
10	IN 10+	IN 10+
11	IN 11+	IN 11+
12	IN 12+	IN 12+
13	EQ GND	EQ GND
14	IN 1-	IN 1-
15	IN 2-	IN 2-
16	IN 3-	IN 3-
17	IN 4-	IN 4-
18	IN 5-	IN 5-
19	IN 6-	IN 6-
20	IN 7-	IN 7-
21	IN 8-	IN 8-
22	IN 9-	IN 9-
23	IN 10-	IN 10-
24	IN 11-	IN 11-
25	IN 12-	IN 12-
26	EQ GND	EQ GND

IA TO FITA J2 CABLE CONNECTIONS

PIN#	IA J2	FITA J2
1	IN 13+	IN 13+
2	IN 14+	IN 14+
3	IN 15+	IN 15+
4	IN 16+	IN 16+
5	IN 17+	IN 17+
6	IN 18+	IN 18+
7	IN 19+	IN 19+
8	IN 20+	IN 20+
9	IN 21+	IN 21+
10	IN 22+	IN 22+
11	IN 23+	IN 23+
12	IN 24+	IN 24+
13	EQ GND	EQ GND
14	IN 13-	IN 13-
15	IN 14-	IN 14-
16	IN 15-	IN 15-
17	IN 16-	IN 16-
18	IN 17-	IN 17-
19	IN 18-	IN 18-
20	IN 19-	IN 19-
21	IN 20-	IN 20-
22	IN 21-	IN 21-
23	IN 22-	IN 22-
24	IN 23-	IN 23-
25	IN 24-	IN 24-
26	EQ GND	EQ GND

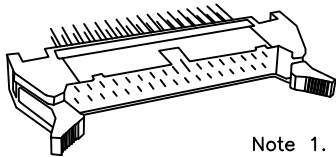

Note 1.

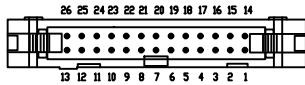

CABLE INTERFACE

IA	FITA
FITA J1	IA J1
FITA J2	IA J2

- NOTE:
 1. Hirose Electric Model HIF3BA-26PA-2.54DSA or equivalent.
 2. Input Assembly = IA

TITLE: INPUT ASSEMBLY TO FITA DETAILS	
	NO SCALE
TEES 2026	A7-22

FITA TERMINAL LABELS

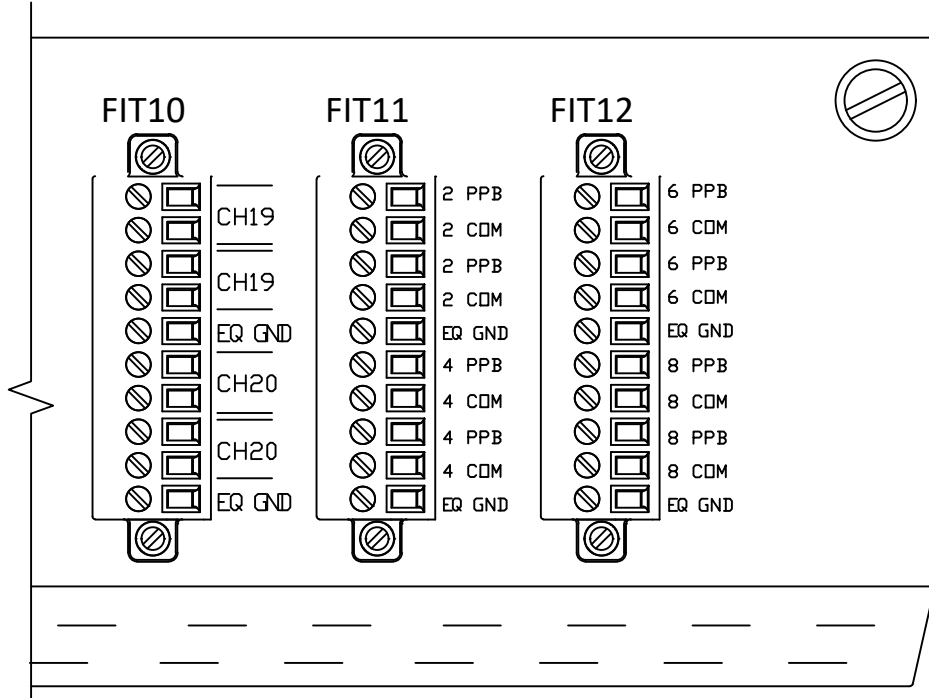

FIT- #1

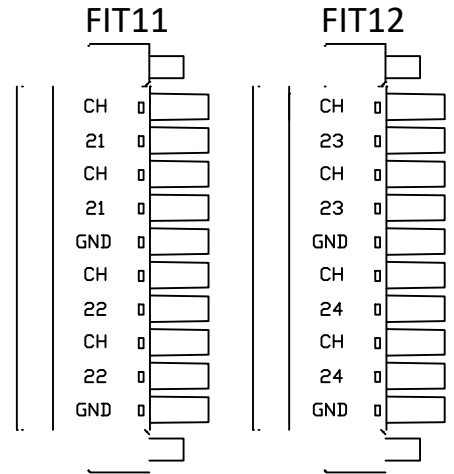

SIDE VIEW
(See Note 2)

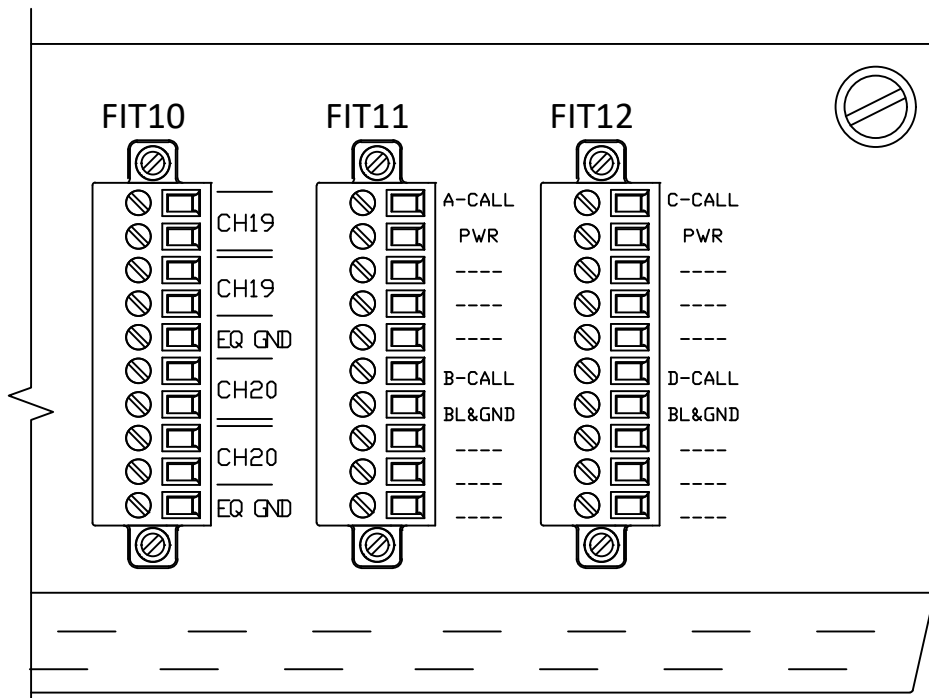

FIT- #2

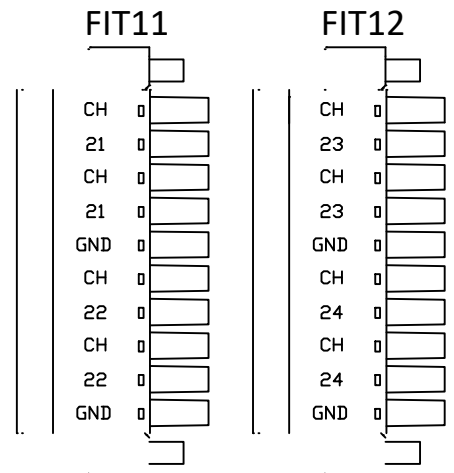

SIDE VIEW
(See Note 2)

NOTE:
1. Field Input Terminal = FIT
2. Label on plug for FIT11 and FIT12 only.

TITLE: FIT- TERMIN-L L-BELS	
	NO SCALE
TEES 2026	A7-23

AUXILIARY INPUT/OUTPUT ASSEMBLY
AND POWER CONNECTOR DETAILS

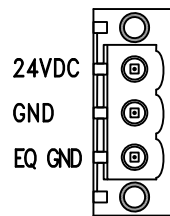
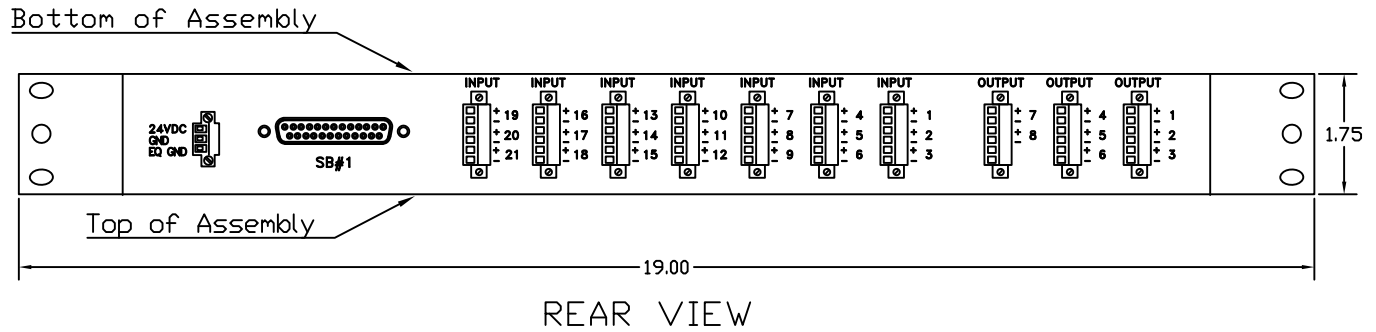
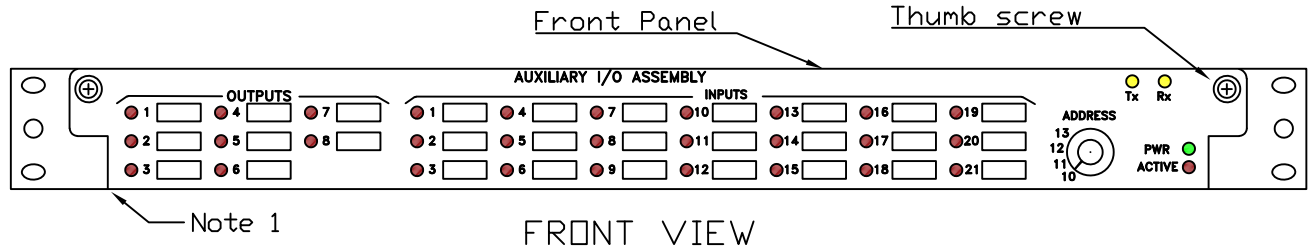

NOTE:

1. Front panel shall be removable from hinges.
2. Power Connector, Phoenix Contact model 1777086 or equivalent.
3. Serial Port #1 (SB#1), connector DB25F.
4. All dimensions shown are in inches.

TITLE: AUXILIARY INPUT/OUTPUT ASSEMBLY AND POWER CONNECTOR DETAILS	
	NO SCALE
TEES 2026	A7-24

AUXILIARY INPUT/OUTPUT ASSEMBLY ADDRESS

AUXILIARY INPUT & OUTPUT ASSEMBLY		
I/O ADDRESS#	INPUT OR OUTPUT	FUNCTION
0	Input	Input 1
1	Input	Input 2
2	Input	Input 3
3	Input	Input 4
4	Input	Input 5
5	Input	Input 6
6	Input	Input 7
7	Input	Input 8
8	Input	Input 9
9	Input	Input 10
10	Input	Input 11
11	Input	Input 12
12	Input	Input 13
13	Input	Input 14
14	Input	Input 15
15	Input	Input 16
16	Input	Input 17
17	Input	Input 18
18	Input	Input 19
19	Input	Input 20
20	Input	Input 21
21	Output	Output 1
22	Output	Output 2
23	Output	Output 3
24	Output	Output 4
25	Output	Output 5
26	Output	Output 6
27	Output	Output 7
28	Output	Output 8

TITLE:	
AUXILIARY INPUT/OUTPUT ASSEMBLY ADDRESS	
	NO SCALE
TEES 2026	A7-25

Railroad Preemption Assembly
Power Connector

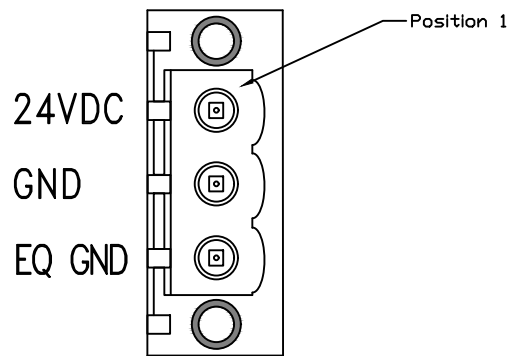

NOTE:
1. Phoenix Contact model 1777086 or equivalent.

TITLE: Railroad Preemption Assembly Power Connector	
	NO SCALE
TEES 2026	A7-26

RAILROAD INPUT/OUTPUT ASSEMBLY ADDRESS

RAILROAD ASSEMBLY		
I/O ADDRESS#	INPUT OR OUTPUT	FUNCTION
0	Input	ADV PRI
1	Input	ADV SEC
2	Input	SIM PRI
3	Input	SIM SEC
4	Input	APP
5	Input	GD
6	Input	ISL
7	Output	Fault
8	Unused	Unused
9	Output	Watch Dog

NOTE:

1. The "Fault" output line shall be connected to a relay. When in normal operation, this output is activated and a normally open contact is closed. When a fault occurs, this output is deactivated, opening the contact and disabling the isolated health signal.
2. Watch Dog shall be implemented per section 6.1.3 of the ATC Standard 5301 v2.

TITLE: RAILROAD I/O ASSEMBLY ADDRESS	
	NO SCALE
TEES 2026	A7-27

RAILROAD PREEMPTION ASSEMBLY

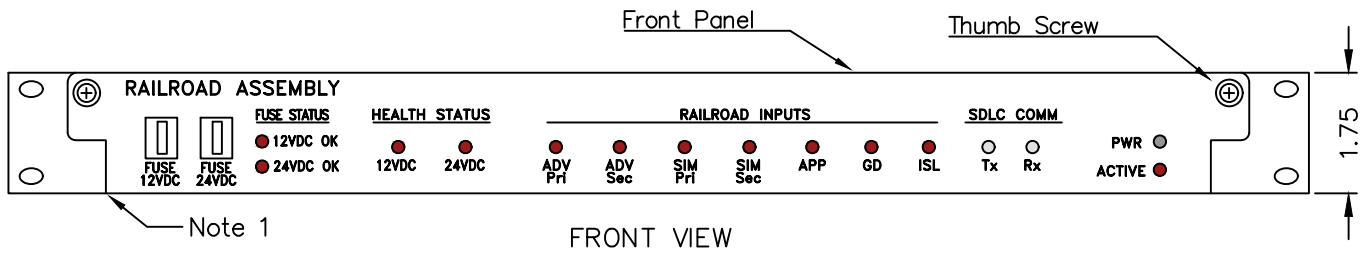
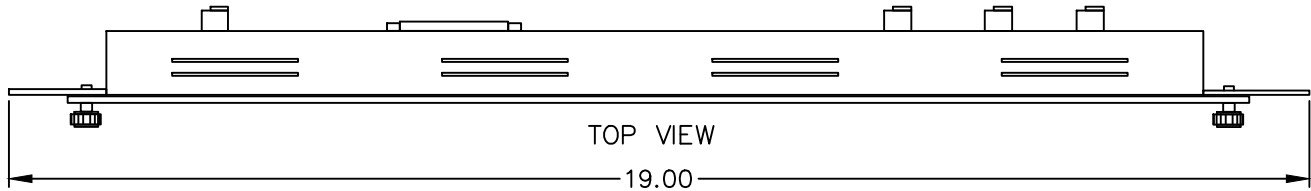

NOTE:

1. Front panel shall be removable from hinges.
2. Serial Port #1 (SB#1), connector DB25F.
3. All dimensions shown are in inches.

TITLE: RAILROAD PREEMPTION ASSEMBLY	
	NO SCALE
TEES 2026	A7-28

MODEL 352ATC – OPTIONAL IFA #3

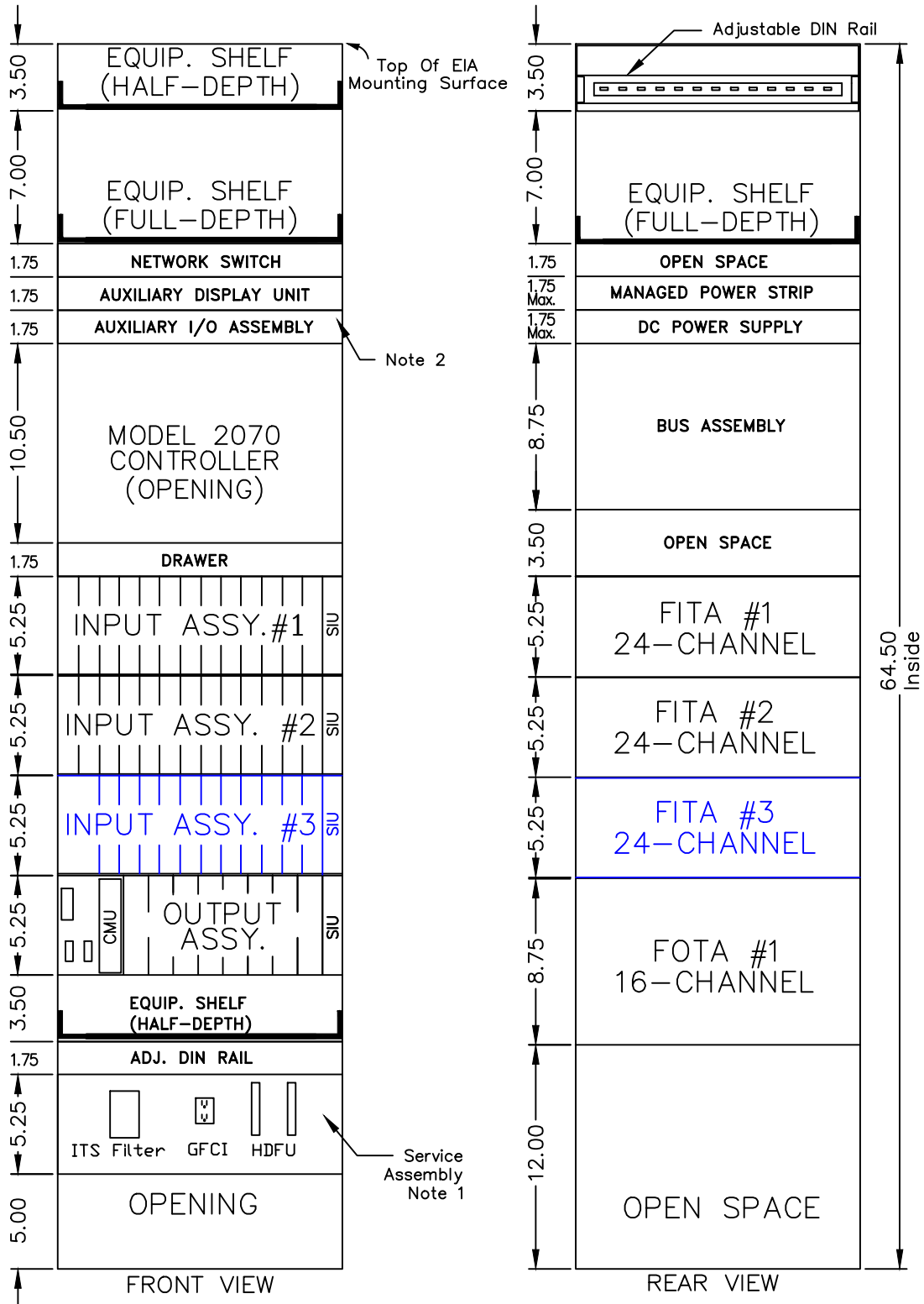

NOTE:

1. Service Assembly rack-mounted, all service conductors connections in the rear.
2. Auxiliary I/O Assembly removable from hinges.
3. All FITA, FOTA and bus assembly panels shall be hinged.
4. All switches shall have a switch guard.
5. All dimensions shown are in inches.

TITLE: MODEL 352ATC CABINET OPTIONAL IFA #3, FITA #3 EQUIPMENT MOUNTING DETAILS	
	NO SCALE
TEES 2026	A7-29

MODEL 352ATC – OPTIONAL OFA #2

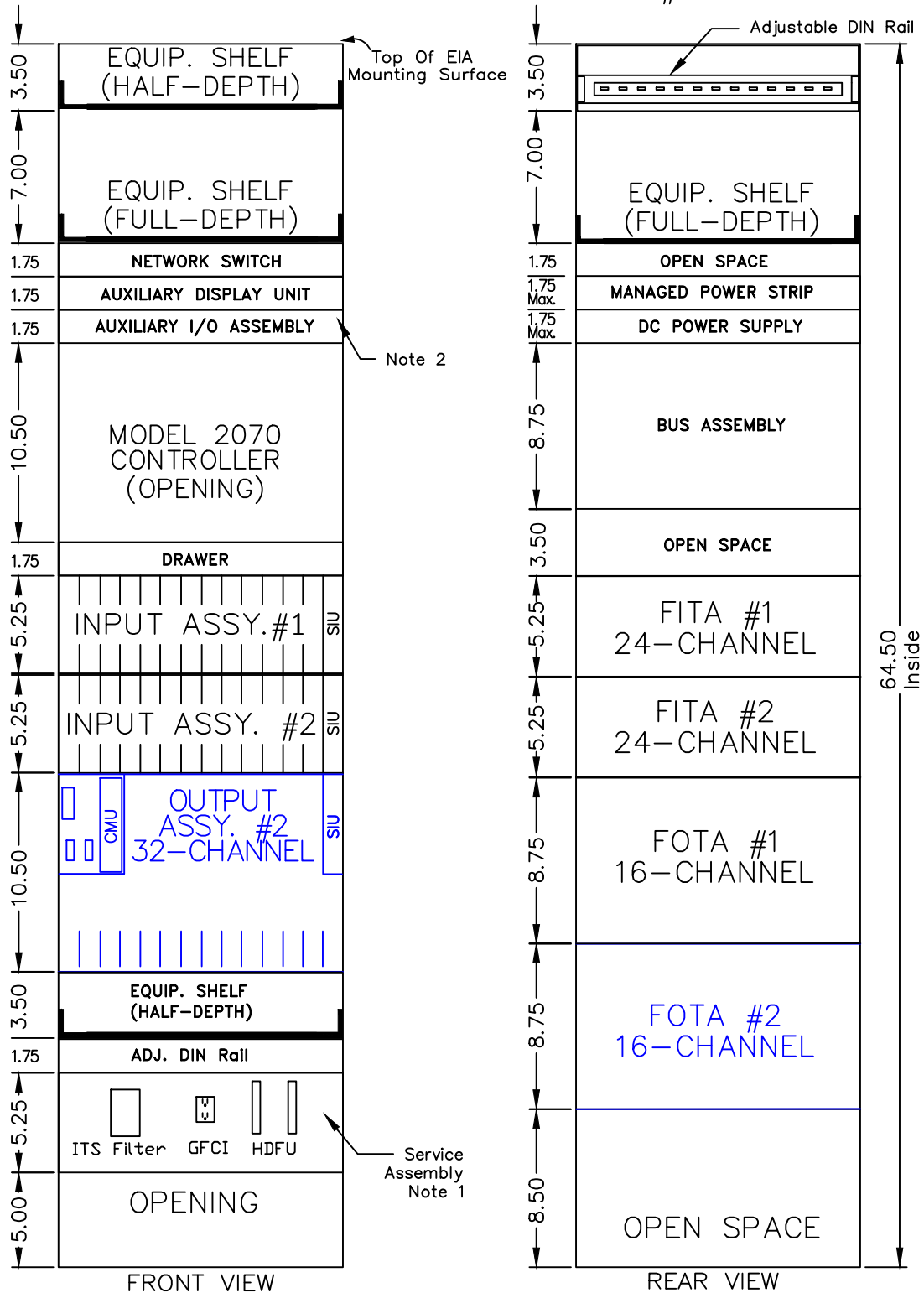

- NOTE:
1. Service Assembly rack-mounted, all service conductors connections in the rear.
 2. Auxiliary I/O Assembly removable from hinges.
 3. All FITA, FOTA and bus assembly panels shall be hinged.
 4. All switches shall have a switch guard.
 5. All dimensions shown are in inches.

TITLE: MODEL 352ATC CABINET OPTIONAL OFA #2 AND FOTA #2 EQUIPMENT MOUNTING DETAILS	
	NO SCALE
TEES 2026	A7-30

MODEL 352ATC – OPTIONAL IFA #3, OFA #2

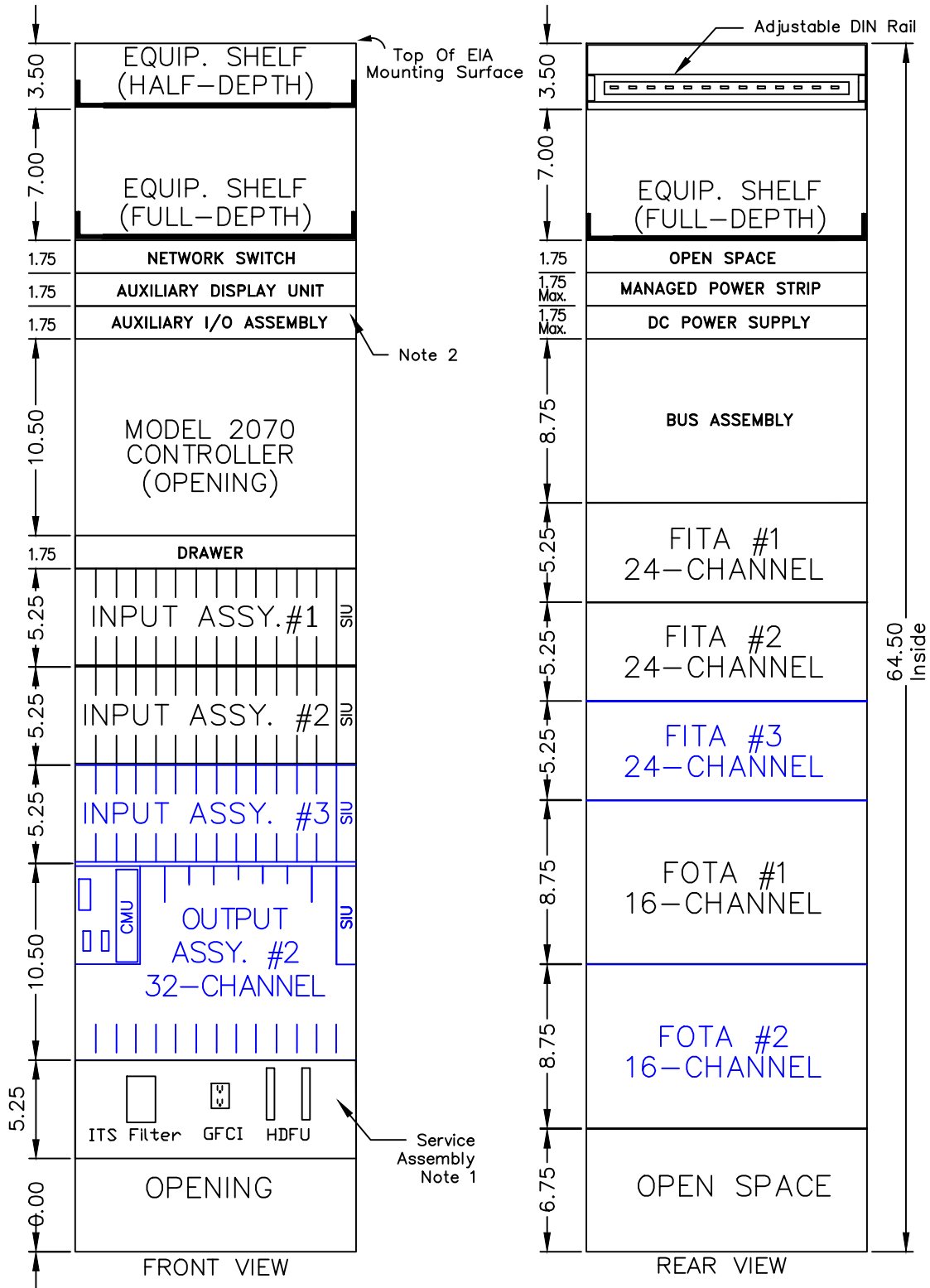

NOTE:

1. Service Assembly rack-mounted, all service conductors connections in the rear.
2. Auxiliary I/O Assembly removable from hinges.
3. All FITA, FOTA and bus assembly panels shall be hinged.
4. All switches shall have a switch guard.
5. All dimensions shown are in inches.

TITLE: MODEL 352ATC CABINET OPTIONAL IFA #3, OFA #2 EQUIPMENT MOUNTING DETAILS	
	NO SCALE
TEES 2026	A7-31

MODEL 362ATC CABINET — OPTIONAL IFA #3
FRONT VIEW

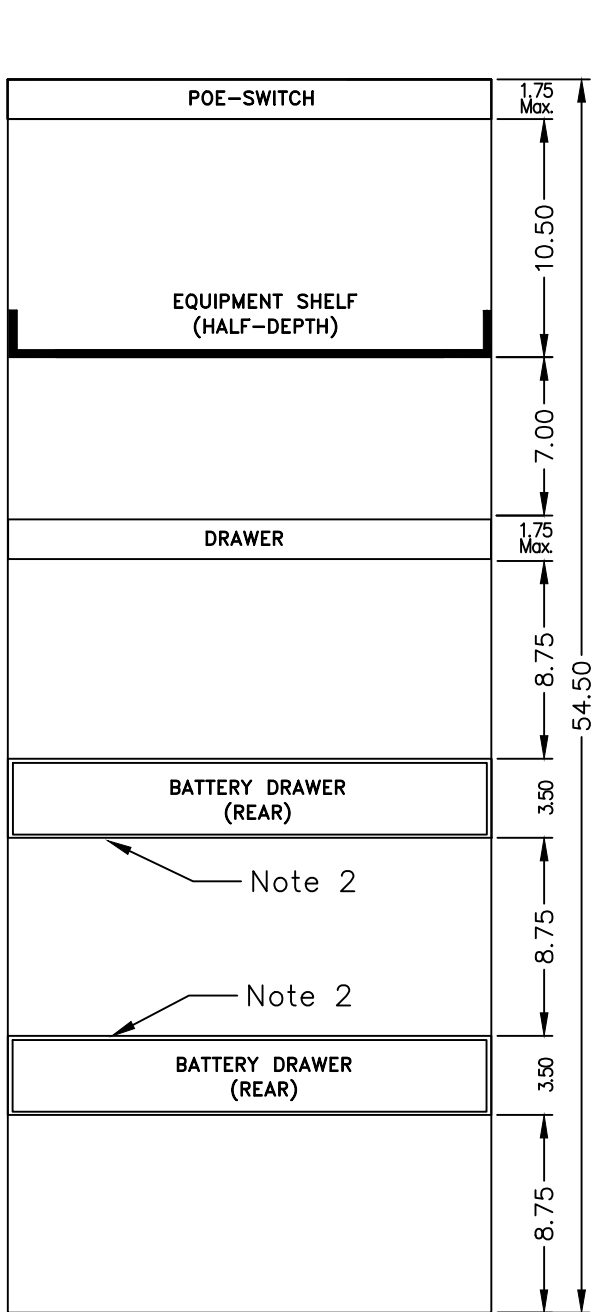

FRONT VIEW
(Rack 2)

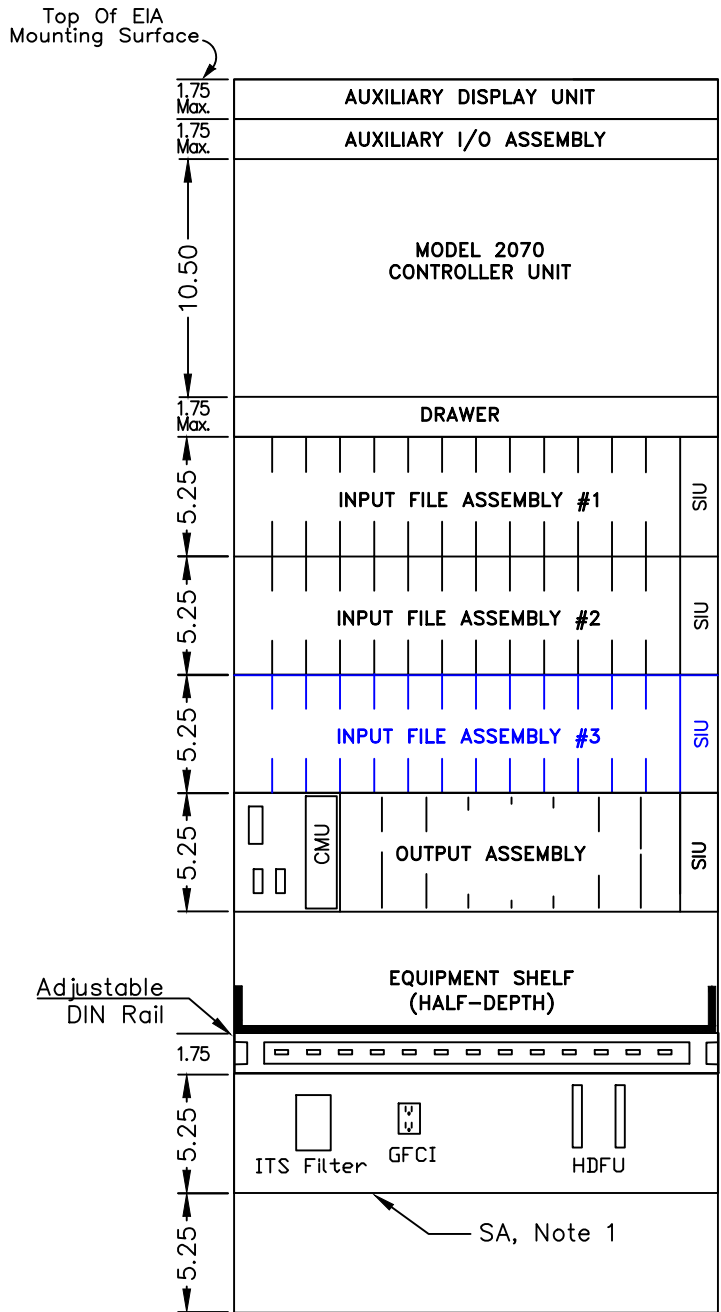

FRONT VIEW
(Rack 1)

NOTE:

1. Service Assembly shall be rack-mounted, all service conductors connections in the rear.
2. Battery Drawer pulls-out at rear of cabinet.
3. Auxiliary I/O Assembly removable from hinges.
4. All switches shall have a switch guard.
5. All dimensions shown are in inches.

TITLE:	MODEL 362ATC CABINET OPTIONAL IFA #3 EQUIPMENT MOUNTING DETAILS	
	NO SCALE	
TEES 2026	A7-32	

MODEL 362ATC CABINET – OPTIONAL IFA #3
REAR VIEW

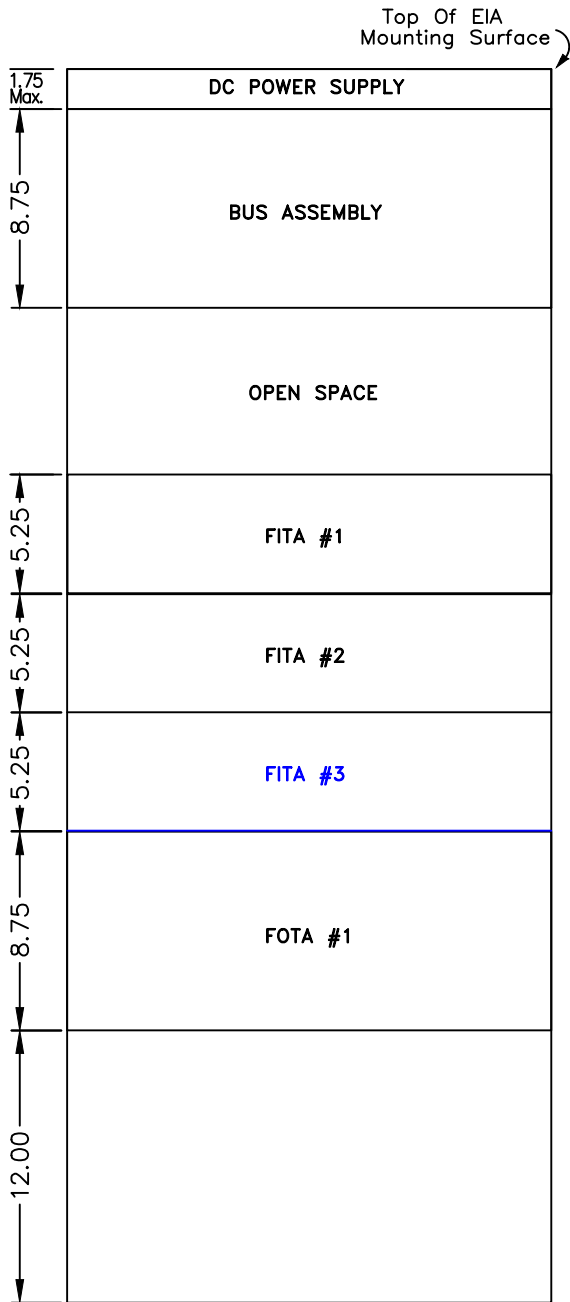

(Rack 1)

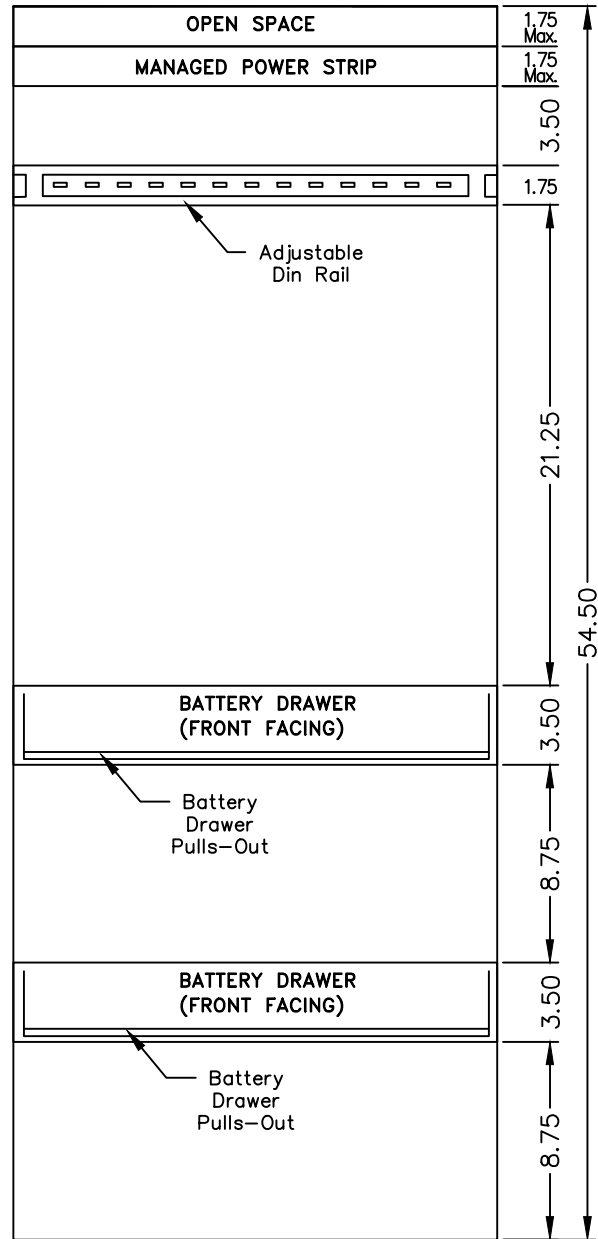

(Rack 2)

NOTE:

1. All FITA, FOTA and bus assembly panels shall be hinged.
2. All dimensions shown are in inches.

TITLE: MODEL 362ATC CABINET OPTIONAL IFA #3 EQUIPMENT MOUNTING DETAILS	
	NO SCALE
TEES 2026	A7-33

MODEL 362ATC CABINET — OPTIONAL OFA #2
FRONT VIEW

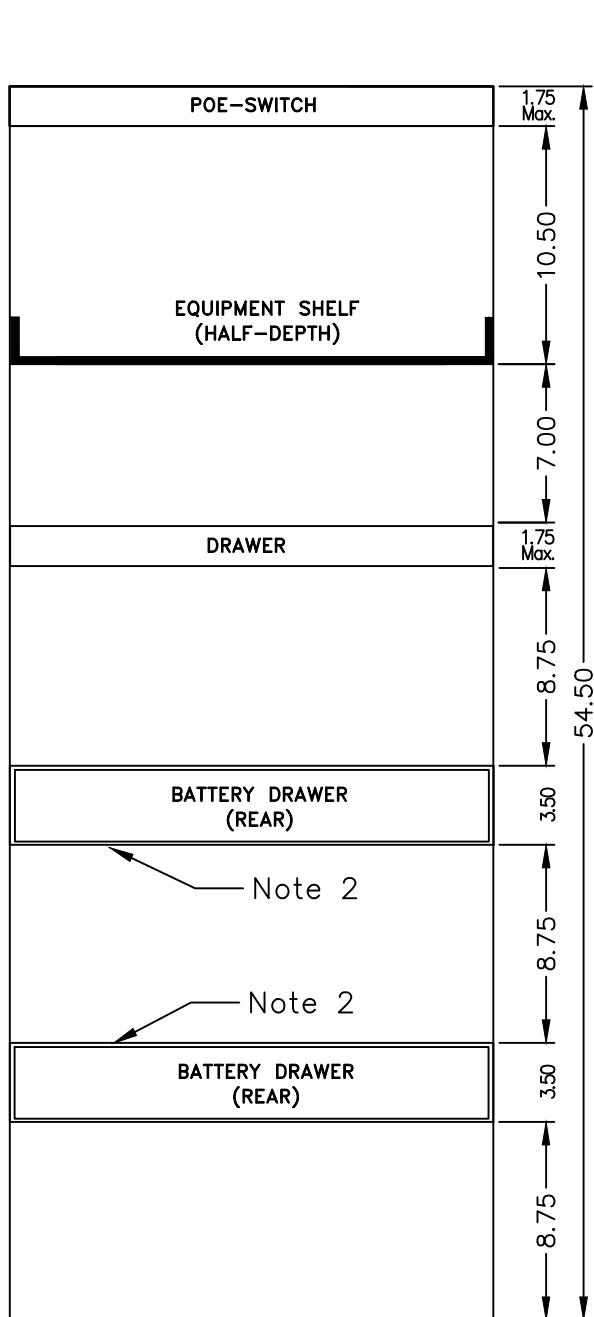

FRONT VIEW
(Rack 2)

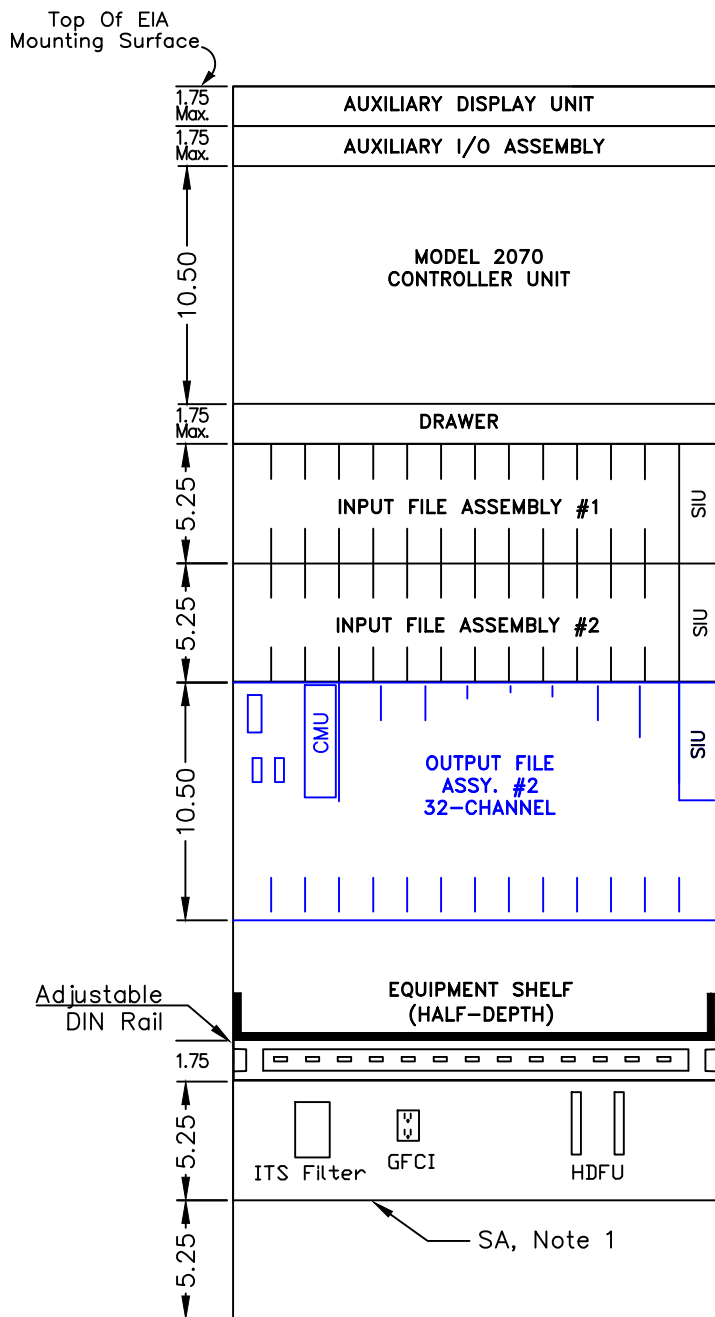

FRONT VIEW
(Rack 1)

NOTE:

1. Service Assembly shall be rack-mounted, all service conductors connections in the rear.
2. Battery Drawer pulls-out at rear of cabinet.
3. Auxiliary I/O Assembly removable from hinges.
4. All switches shall have a switch guard.
5. All dimensions shown are in inches.

TITLE:	MODEL 362ATC CABINET OPTIONAL OFA #2 EQUIPMENT MOUNTING DETAILS
	NO SCALE
TEES 2026	A7-34

MODEL 362ATC CABINET – OPTIONAL OFA #2
REAR VIEW

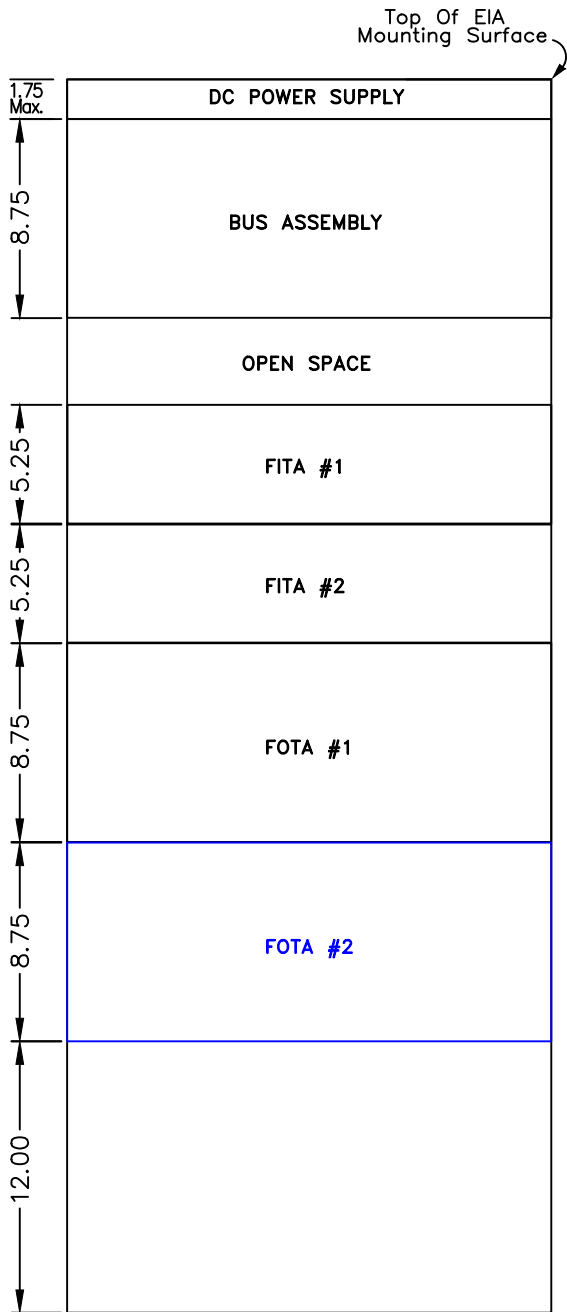

(Rack 1)

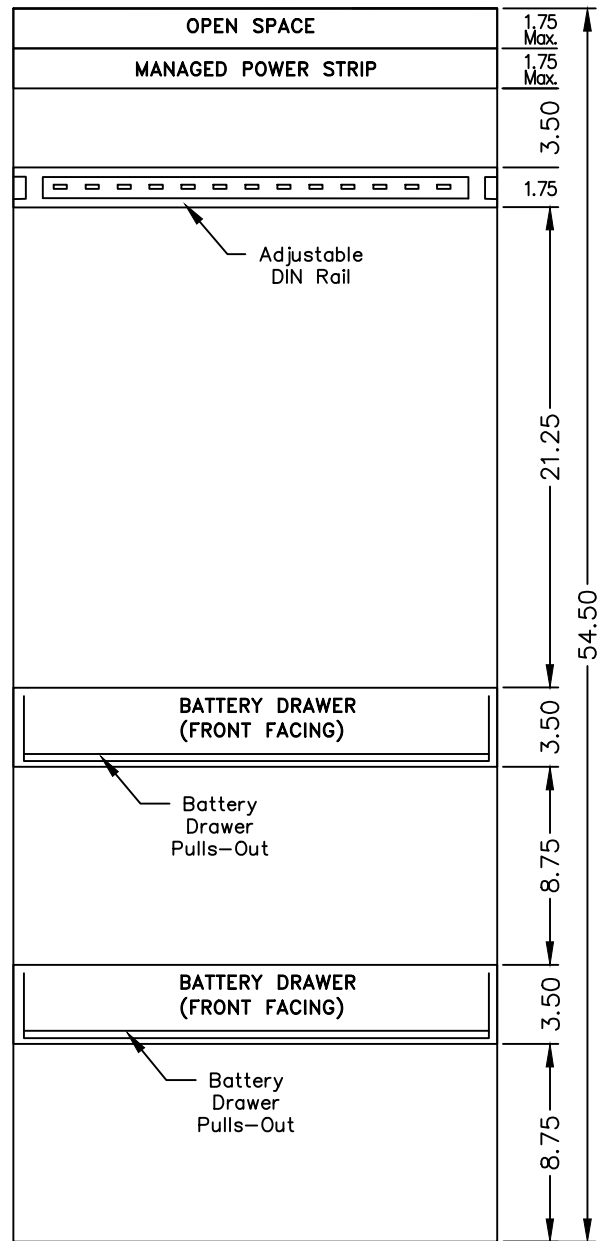

(Rack 2)

NOTE:

1. All FITA, FOTA and bus assembly panels shall be hinged.
2. All dimensions shown are in inches.

TITLE: MODEL 362ATC CABINET OPTIONAL OFA #2 EQUIPMENT MOUNTING DETAILS	
	NO SCALE
TEES 2026	A7-35

MODEL 362ATC CABINET – OPTIONAL IFA #3 & OFA #2 FRONT VIEW

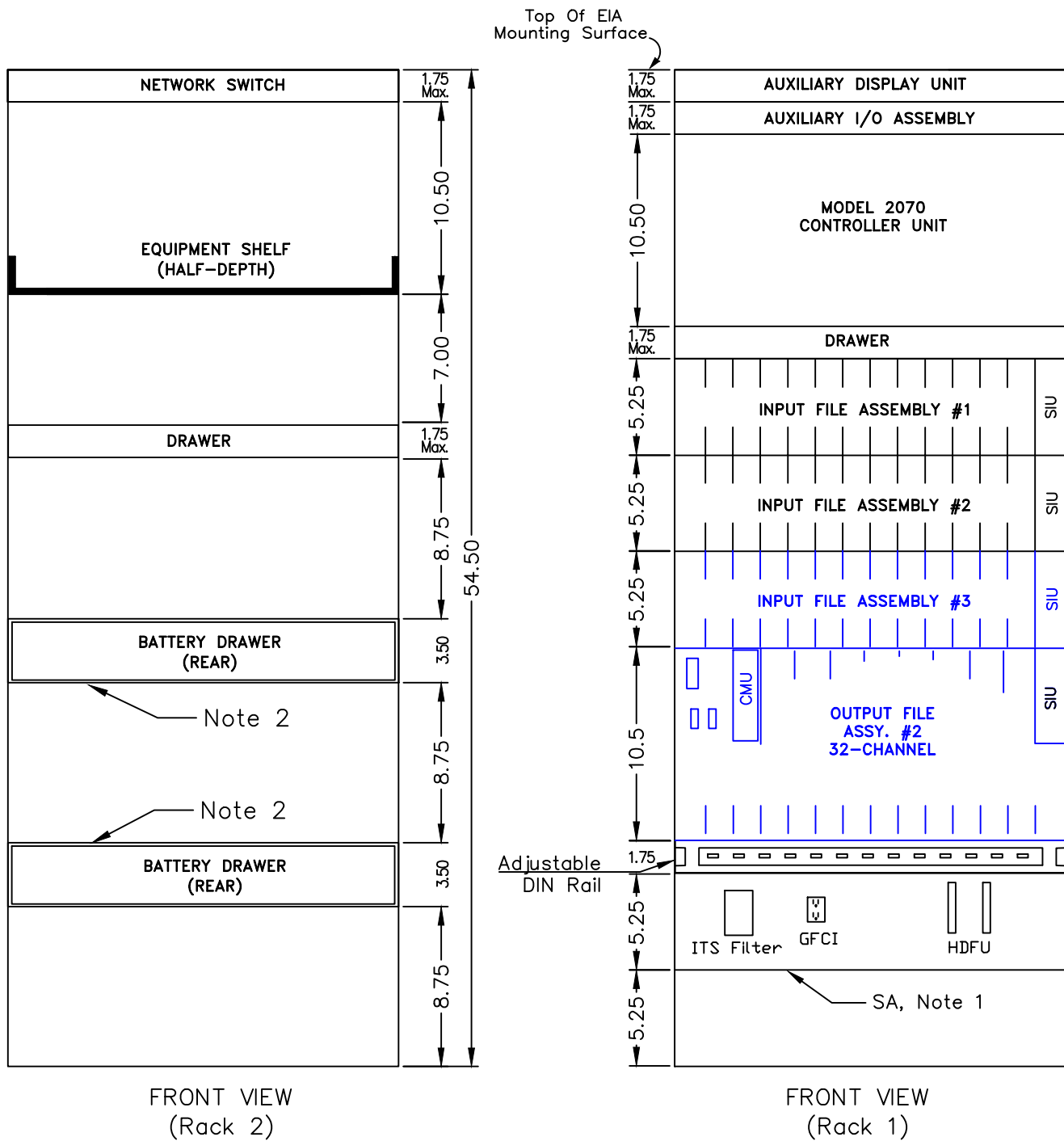

FRONT VIEW
(Rack 2)

FRONT VIEW
(Rack 1)

NOTE:

1. Service Assembly shall be rack-mounted, all service conductors connections in the rear.
2. Battery Drawer pulls-out at rear of cabinet.
3. Auxiliary I/O Assembly removable from hinges.
4. All switches shall have a switch guard.
5. All dimensions shown are in inches.

TITLE:	MODEL 362ATC CABINET OPTIONAL IFA #3 & OFA #2 EQUIPMENT MOUNTING DETAILS
	NO SCALE
TEES 2026	A7-36

MODEL 362ATC CABINET – OPTIONAL IFA #3 & OFA #2
 REAR VIEW

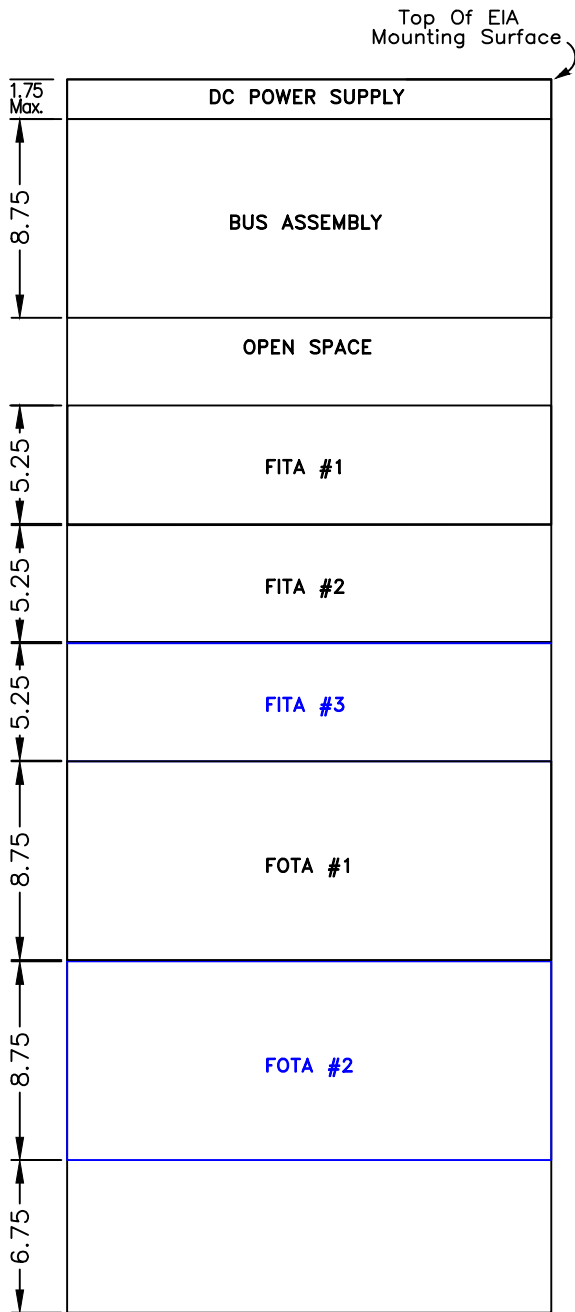

(Rack 1)

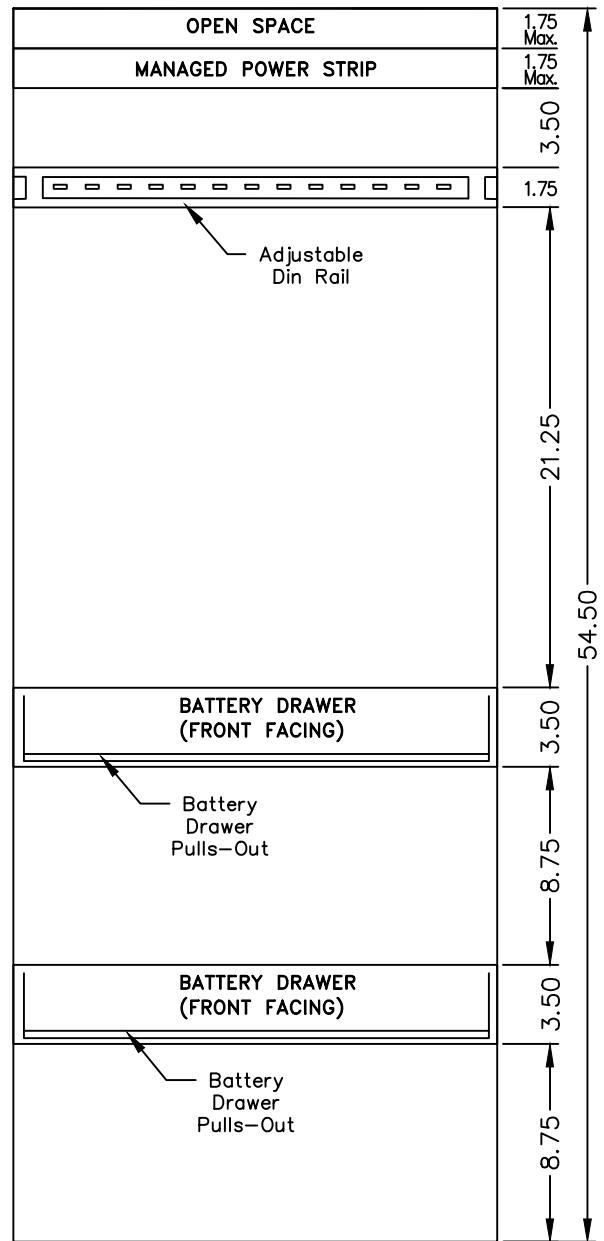

(Rack 2)

NOTE:

1. All FITA, FOTA and bus assembly panels shall be hinged.
2. All dimensions shown are in inches.

TITLE: MODEL 362ATC CABINET OPTIONAL IFA #3 & OFA #2 EQUIPMENT MOUNTING DETAILS	
	NO SCALE
TEES 2026	A7-37