



# DISCLAIMER

This document is disseminated in the interest of information exchange. The contents of this report reflect the views of the authors who are responsible for the facts and accuracy of the data presented herein. The contents do not necessarily reflect the official views or policies of the State of California or the Federal Highway Administration. This publication does not constitute a standard, specification, or regulation. This report does not constitute an endorsement by the Department of any product described herein.

For individuals with sensory disabilities, this document is available in alternate formats. For information, call (916) 654-8899, TTY 711, or write to California Department of Transportation, Division of Research, Innovation and System Information, MS-83, P.O. Box 942873, Sacramento, CA 94273-0001.



# **Advanced Highway Maintenance and Construction Technology Research Center**

Department of Mechanical and Aerospace Engineering  
University of California at Davis

## **Mobile Electric Vehicle DCFC Infrastructure Deployment Opportunities**

Farhang Motallebi, Evan Sim, Meridian Haas &  
Shima Nazari: Principal Investigator

Report Number: TBD

AHMCT Research Report: UCD-ARR-25-09-30-01

Final Report of Contract: 65A0749 Task 4409

DATE: 09-24-2025

## **California Department of Transportation**

Division of Research, Innovation and System Information

# Executive Summary

## Problem, Need, and Purpose of Research

California Department of Transportation (Caltrans) is transitioning its vehicle fleet to electric vehicles (EVs) but currently faces challenges due to inadequate charging infrastructure. These infrastructure gaps cause operational delays, reduced fleet efficiency, and increased operational risks. To address these issues, Caltrans requires reliable mobile and semi-permanent direct current fast charging (DCFC) EV charging solutions. This study evaluates two charging systems, the EVESCO EVES-6060-NA and FreeWire Boost Charger 200, to determine their suitability for addressing Caltrans' specific operational challenges, compatibility concerns, and performance expectations.

## Overview of the Work and Methodology

The research involved thorough testing and evaluation of two charging solutions under various operational conditions, specifically ease of operation, vehicle compatibility, infrastructure requirements, charging performance, and data collection capabilities.

## Major Results and Recommendations

### EVESCO EVES-6060-NA Findings:

Our testing and analysis revealed several critical operational insights regarding the EVESCO EVES-6060-NA mobile charger:

- **Vehicle Compatibility:** Compatible with 7 out of 7 Caltrans fleet vehicles.
- **Charging Performance:** 88% to 92% efficiency; 25-50kW power delivery; provides 35-50kWh per full charge.
- **DCFC Compatibility:** 35% success rate (8/23 chargers); ChargePoint stations are the most reliable.
- **Operational Requirements:** Requires a trailer for mobility, internet connectivity, and 480V alternating current (AC) power to be charged at Caltrans sites.
- **Limitations:** Intermittent Tesla charging issues; battery cell error in cold weather; lacks comprehensive onboard or cloud data collection.

## FreeWire Boost Charger 200 Key Findings:

Our testing and analysis revealed several critical operational insights regarding the FreeWire Boost Charger 200:

- **Installation Requirements:** Requires permanent foundation work. There were significant permitting delays with the Office of the State Fire Marshal (OSFM).
- **Usage Patterns:** Public combined charging system type 1 (CCS1) ports averaged four charging sessions daily, while CHAdeMO ports averaged only four weekly sessions; campus units showed minimal utilization (8 charges/month).
- **Battery Management:** Current high state-of-charge (SOC) setpoint (98.5%) significantly accelerates battery degradation.
- **Infrastructure Needs:** Requires minimum three-phase 208V AC power to charge internal battery.

## Key Recommendations:

- **EVESCO EVES-6060-NA Deployment:** Deploy this unit at locations with 480V AC power or compatible DCFCs. Ensure dedicated trailers are available and reliable internet connectivity is present at all deployment sites. Implement protocols for cold weather operation, including pre-heating procedures when temperatures drop below 40°F. Develop a manual data collection system to track usage patterns and performance metrics. Account for potential 8- to 12-week delivery delays during procurement planning.
- **FreeWire Boost Charger 200 Deployment:** Plan and budget for required foundation work. Begin fire marshal permitting process early to avoid deployment delays. Reduce the battery SOC setpoint from the current 98.5% to 55% to 70% range to significantly extend battery life while maintaining operational readiness. Place units strategically based on projected usage needs to prevent underutilization. Maintain software subscriptions to ensure continued access to performance data for optimization.
- **Future Research:** Several areas for future research would benefit Caltrans' mobile charging operations.
- **Extended Testing:** Test both discussed systems with more vehicles over more extended periods.
- **Additional Technologies:** Evaluate mobile charging solutions from other manufacturers.

- **Battery Longevity:** Monitor FreeWire Boost Charger 200 battery degradation when using lower SOC setpoints.
- **Cold Weather Performance:** Further test EVESCO performance during prolonged cold exposure.

# Table of Contents

Executive Summary	ii
Problem, Need, and Purpose of Research	ii
Overview of the Work and Methodology	ii
Major Results and Recommendations	ii
Table of Contents	v
Figures	viii
Tables	xvii
Acronyms and Abbreviations	xviii
Acknowledgments	xx
Chapter 1: Introduction	21
Problem	21
Objectives	22
Scope	22
Research Methodology	22
Overview of Research Results and Benefits	23
Chapter 2: Product Search for Mobile and Semi-Permanent DCFCs	24
Dannar Mobile	24
EVESCO EVES Series	25
EVESCO EVMO Series	26
Lightning e-Motors Lightning Mobile Series	26
Portable Electric Voltstack 30k	27
XOS Energy Solutions	27
FreeWire	28
Specifications of selected units:	29
EVESCO EVES-6060-NA	29
FreeWire Boost Charger 200	30
Chapter 3: System Installation and Setup	32
EVESCO EVES-6060-NA	32
Procurement Timeline	32
ATIRC 480 V Panel Modifications	33
Trailer Procurement	34
System Setup	36
Data Acquisition	39

EVES-6060-NA Operating Manual _____	45
FreeWire Boost Charger 200 _____	45
System Setup _____	45
Data Acquisition _____	51
Chapter 4: EVESCO EVES-6060-NA System Evaluation _____	53
Compatibility with Vehicles _____	54
Chevrolet Bolt Compatibility Testing _____	56
Chevrolet Equinox Compatibility Testing _____	58
Chevrolet Silverado EV Compatibility Testing _____	60
Ford F-150 Lightning Compatibility Testing _____	62
Global M4 HSD Compatibility Testing _____	64
Tesla Model 3 Compatibility Testing _____	67
Tesla Model S Compatibility Testing _____	70
Tesla Model Y Compatibility Testing _____	72
Volkswagen ID.4 Compatibility Testing _____	74
Volvo NRE62T Compatibility Testing _____	77
Compatibility with 480V AC Charger _____	78
Compatibility with DCFCs _____	80
Temperature Balance Error _____	90
Battery Emulator Testing _____	92
Man in the Middle Testing _____	92
DCFC Compatibility Diagnostics (Keysight PLC Tracer) _____	95
Chapter 5: FreeWire Boost Charger 200 System Evaluation _____	104
Mountain View FreeWire Boost Charger 200 Evaluation _____	104
Morgan Hill FreeWire Boost Charger 200 Evaluation _____	112
UC Davis FreeWire Boost Charger 200 Evaluation _____	119
Caltrans FreeWire Boost Charger 200 Evaluation _____	124
FreeWire Boost Charger 200 Battery Capacity Degradation from Long-term Usage _____	131
Smart Operation of FreeWire Boost Charger 200 _____	135
Reported Specifications _____	137
Chapter 6: Conclusions and Future Research _____	139
Conclusions and Recommendations _____	139
Research Fulfillment and Achievement _____	139
Deviations from Planned Research _____	139
Summary of Key Findings _____	140
EVESCO EVES-6060-NA Key Findings _____	140
FreeWire Boost Charger 200 Key Findings _____	140

Value for Caltrans _____	141
Recommendations _____	141
For EVESCO EVES-6060-NA Deployment _____	142
For FreeWire Boost Charger 200 Deployment _____	142
Lessons Learned _____	143
Future Research Directions _____	144
References _____	145
Appendix A: Charging Performance Data and SOC Analysis for EVES-6060-NA Sessions _____	146
Vehicle Charging _____	146
Grid Charging (480V AC) _____	156
DC Fast Charging _____	159
Appendix B: EVES-6060-NA Operating Instructions _____	166
Before Energizing _____	166
Charging from Another DCFC (DC) _____	167
Charging from Grid (AC) _____	171
Charging an EV _____	174
Appendix C: Drawing for 7-pin Connector for Zieman 1166-S Trailer _____	178
Appendix D: Charging Chevrolet Silverado EV with FreeWire Boost Charger 200 _____	179

# Figures

Figure 3.1: ATIRC layout with EVES-6060-NA positioned for direct breaker access \_\_\_\_\_ 34

Figure 3.2: Ziemann 1166-S Flat Deck Type trailer at ATIRC \_\_\_\_\_ 35

Figure 3.3: Shipment of EVES-6060-NA to ATIRC \_\_\_\_\_ 36

37

Figure 3.4: EVES-6060-NA interior and battery modules mounted \_\_\_\_\_ 37

Figure 3.5: Mounting solution for attaching EVES-6060-NA to truck or trailer \_\_\_\_\_ 38

Figure 3.6: SOLIDWORKS drawing of mounting plate \_\_\_\_\_ 38

Figure 3.7: Mounting solution for attaching EVES-6060-NA to truck (including ratchet straps) \_\_\_\_\_ 39

41

Figure 3.8: “Page Not Found” screen shown when trying to access telemetry data from ChargeMetric \_\_\_\_\_ 41

Figure 3.9: Screenshot of screen recording from front display of EVES-6060-NA (during charging) \_\_\_\_\_ 42

Figure 3.10: Screenshot of screen recording from front display of EVES-6060-NA (during discharging) \_\_\_\_\_ 43

Figure 3.11: Flow of outputs from scripts ending in data table in .csv format \_\_\_\_\_ 43

Figure 3.12: Current, Voltage, and SOC for EV and the EVES-6060-NA charger, along with the High and Low Cell Temperature from a Sample Charging of a Volkswagen ID.4. The data acquired through recording the screen of the EVES-6060-NA. \_\_\_\_\_ 44

Figure 3.13: Photos showing final commissioning of FreeWire Boost Charger 200 \_\_\_\_\_ 46

Figure 3.14: Photos showing panel installed behind FreeWire Boost Charger 200 and protective rails \_\_\_\_\_ 47

Figure 3.15: Main conduit wiring terminations on the front of FreeWire Boost Charger 200 \_\_\_\_\_ 48

Figure 3.16: Photos showing testing FreeWire Boost Charger 200 during final commissioning process at Magaña Ortega Maintenance Yard \_\_\_\_\_ 48

Figure 3.17: Front display of FreeWire Boost Charger 200 showing SOC indicator and warning indicating that the other CCS1 port was using all available power \_\_\_\_\_ 49

Figure 3.18: Sierra Wireless MP70 installed on Caltrans' FreeWire Boost Charger 200. After setup, the modem showed a solid green network and Wi-Fi LEDs. The activity LED was flashing amber, indicating that data was being transferred successfully via the ethernet port. \_\_\_\_\_ 50

Figure 4.1: Chevrolet Bolt being charged by the EVES-6060-NA \_\_\_\_\_ 56

Figure 4.2: EVES-6060-NA and EV SOC, Current, Voltage, Power, and Minimum and Maximum Battery Cell temperatures for charging session of Chevrolet Bolt by the EVES-6060-NA unit. _____	57
Figure 4.3: Chevrolet Equinox being charged by the EVES-6060-NA _____	58
Figure 4.4: EVES-6060-NA and EV SOC, Current, Voltage, Power, and Minimum and Maximum Battery Cell temperatures for charging session of Chevrolet Equinox by the EVES-6060-NA unit. _____	59
Figure 4.6: Chevrolet Silverado EV being charged by the EVES-6060-NA _____	60
Figure 4.7: EVES and EV SOC, Current, Voltage, Power, and Minimum and Maximum Battery Cell temperatures for charging session of Chevrolet Silverado EV by the EVES-6060-NA unit. _____	62
Figure 4.8: Ford F150 Lightning being charged by the EVES-6060-NA _____	62
Figure 4.10: Global M4 HSD being charged by the EVES-6060-NA. _____	65
Figure 4.12: Tesla Model 3 being charged by the EVES-6060-NA. _____	67
Figure 4.14: Tesla Model S being charged by the EVES-6060-NA. _____	70
Figure 4.15: EVES and EV SOC, Current, Voltage, Power, and Minimum and Maximum Battery Cell temperatures for charging session of Tesla Model S by the EVES-6060-NA unit _____	72
Figure 4.16: Tesla Model Y being charged by the EVES-6060-NA. _____	72
Figure 4.18: Volkswagen ID.4 being charged by the EVES-6060-NA. _____	74
Figure 4.21: SOC, Current, Voltage, Power, and Minimum and Maximum Battery Cell temperatures for a charging session of EVES-6060-NA by 3-phase 480V AC power at ATIRC facility. _____	79
Figure 4.22: Error screen shown by Electrify America DCFC in Truckee when attempting to charge the EVES-6060-NA _____	82
Figure 4.23: SOC, Current, Voltage, Power, and Minimum and Maximum Battery Cell temperatures for charging session of EVES-6060-NA at the Electrify America DCFC located at the Davis Bank of America. _____	83
Figure 4.26: Locations of the charging stations tested for cold condition testing	87
Figure 4.27: SOC, Current, Voltage, Power, and Minimum and Maximum Battery Cell temperatures for charging session of EVES-6060-NA at the ChargePoint DCFC located in Emigrant Gap _____	89
Figure 4.28: SOC, Current, Voltage, Power, and Minimum and Maximum Battery Cell temperatures for charging session of EVES-6060-NA at the ChargePoint DCFC located in downtown Truckee _____	90
Figure 4.29: Temperature balance error seen on the EVES-6060-NA in cold conditions _____	91
Figure 4.30: Current and Voltage for a charging session of the Chevrolet Bolt by the EVES-6060-NA measured by the emulator and through screen recording _____	92

Figure 4.31: Close up of the Current and Voltage for a charging session of the Chevrolet Bolt by the EVES-6060-NA measured by the emulator and through screen recording _____	93
Figure 4.32: Current and Voltage for a charging session of the Volkswagen ID.4 by the EVES-6060-NA measured by the emulator and through screen recording _____	93
Figure 4.33: Close up of the Current and Voltage for a charging session of the Volkswagen ID.4 by the EVES-6060-NA measured by the emulator and through screen recording _____	94
Figure 4.34: Vector log indicating that the EVES-6060-NA utilizes the DIN spec 70121:2012 charging protocol Close up of the Current and Voltage for a charging session of the Volkswagen ID.4 by the EVES-6060-NA measured by the emulator and through screen recording _____	94
Figure 4.36: PLC trace showing decoded ServiceDiscoveryRes during ISO 15118 V2G communication between EVESCO EVES-6060-NA and EVgo DCFC.____	96
Figure 5.1: Charging Start Times of the CCS1 and CHAdeMO ports of the Mountain View FreeWire Boost Charger 200 _____	105
Figure 5.2: Total Charging Session Times of the CCS1 and CHAdeMO ports of the Mountain View FreeWire Boost Charger 200 _____	105
Figure 5.3: Number of Charging Sessions per Day of the CCS1 and CHAdeMO ports of the Mountain View FreeWire Boost Charger 200 _____	106
Figure 5.4: Number of Charging Sessions per Month of the CCS1 and CHAdeMO ports of the Mountain View FreeWire Boost Charger 200 _____	106
Figure 5.5: Total Energy Transferred per Charging Session of the CCS1 and CHAdeMO ports of the Mountain View FreeWire Boost Charger 200 _____	107
Figure 5.6: Peak Current per Charging Session of the CCS1 and CHAdeMO ports of the Mountain View FreeWire Boost Charger 200 _____	107
Figure 5.7: Peak Voltage per Charging Session of the CCS1 and CHAdeMO ports of the Mountain View FreeWire Boost Charger 200 _____	108
Figure 5.8: Peak Power per Charging Session of the CCS1 and CHAdeMO ports of the Mountain View FreeWire Boost Charger 200 _____	108
Figure 5.9: The Maximum and Minimum Cell Temperatures and the Charger Temperature of the Mountain View FreeWire Boost Charger 200 _____	109
Figure 5.10: Battery SOC, Output Current, Output Voltage, Output Power, and Cell Temperatures for an example Charging Session of the CCS1 Port of the Mountain View FreeWire Boost Charger 200 _____	110
Figure 5.11: Battery SOC, Output Current, Output Voltage, Output Power, and Cell Temperatures for the Charging Session data of the CCS1 and CHAdeMO ports of the Mountain View FreeWire Boost Charger 200 _____	111
Figure 5.12: Error codes during historical operation of the Mountain View FreeWire Boost Charger 200 _____	112

Figure 5.13: Charging Start Times of the CCS1 and CHAdeMO ports of the Morgan Hill FreeWire Boost Charger 200	113
Figure 5.14: Total Charging Session Times of the CCS1 and CHAdeMO ports of the Morgan Hill FreeWire Boost Charger 200	113
Figure 5.15: Number of Charging Sessions per Day of the CCS1 and CHAdeMO ports of the Morgan Hill FreeWire Boost Charger 200	114
Figure 5.16: Total Energy Transferred per Charging Session of the CCS1 and CHAdeMO ports of the Morgan Hill FreeWire Boost Charger 200	114
Figure 5.17: Peak Current per Charging Session of the CCS1 and CHAdeMO ports of the Morgan Hill FreeWire Boost Charger 200	115
Figure 5.18: Peak Voltage per Charging Session of the CCS1 and CHAdeMO ports of the Morgan Hill FreeWire Boost Charger 200	115
Figure 5.19: Peak Power per Charging Session of the CCS1 and CHAdeMO ports of the Morgan Hill FreeWire Boost Charger 200	116
Figure 5.20: The Maximum and Minimum Cell Temperatures and the Charger Temperature of the Morgan Hill FreeWire Boost Charger 200	116
Figure 5.21: Battery SOC, Output Current, Output Voltage, Output Power, and Cell Temperatures for an example Charging Session of the CSS-1 Port of the Morgan Hill FreeWire Boost Charger 200	117
Figure 5.22: Battery SOC, Output Current, Output Voltage, Output Power, and Cell Temperatures for the Charging Session data of the CCS1 and CHAdeMO ports of the Morgan Hill FreeWire Boost Charger 200	118
Figure 5.23: Error codes during historical operation of the Morgan Hill FreeWire Boost Charger 200.	119
Figure 5.24: Charging Current, Voltage, and Power of both CCS1 ports of the FreeWire Boost Charger 200 installed on UC Davis campus.	120
Figure 5.25: SOC of the FreeWire Boost Charger 200 installed on UC Davis campus.	120
Figure 5.26: The Maximum and Minimum Cell Temperatures and the Charger Temperature of the FreeWire Boost Charger 200 installed on UC Davis campus.	121
Figure 5.27: Charging Start Times of the FreeWire Boost Charger 200 installed on UC Davis campus.	121
Figure 5.28: Total Charging Session Times of the FreeWire Boost Charger 200 installed on UC Davis campus.	122
Figure 5.29: Total Energy Transferred per Charging Session of the FreeWire Boost Charger 200 installed on UC Davis campus.	122
Figure 5.30: The Peak Current, Voltage, and Power of Each Charging Session of the FreeWire Boost Charger 200 installed on UC Davis campus.	123
Figure 5.31: The Maximum and Minimum Cell Temperatures and the Charger Temperature of the FreeWire Boost Charger 200 installed on UC Davis campus.	123

Figure 5.32: Error codes during operation of the FreeWire Boost Charger 200 installed on UC Davis campus. _____	124
Figure 5.33: Charging Current, Voltage, and Power of both CCS1 ports of the FreeWire Boost Charger 200 installed at Caltrans _____	125
Figure 5.34: SOC of the FreeWire Boost Charger 200 installed at Caltrans. ____	125
Figure 5.35: The Maximum and Minimum Cell Temperatures and the Charger Temperature of the FreeWire Boost Charger 200 installed at Caltrans. ____	126
Figure 5.36: Charging Start Times of the FreeWire Boost Charger 200 installed at Caltrans. _____	126
Figure 5.37: Total Charging Session Times of the FreeWire Boost Charger 200 installed at Caltrans. _____	127
Figure 5.38: Total Energy Transferred per Charging Session of the FreeWire Boost Charger 200 installed at Caltrans. _____	127
Figure 5.39: The Peak Current, Voltage, and Power of Each Charging Session of the FreeWire Boost Charger 200 installed at Caltrans. _____	128
Figure 5.40: The Maximum and Minimum Cell Temperatures and the Charger Temperature of the FreeWire Boost Charger 200 installed at Caltrans. ____	128
Figure 5.41: Error codes during operation of the FreeWire Boost Charger 200 installed at Caltrans. _____	129
Figure 5.42: FreeWire Boost Charger 200 installed at Caltrans. SOC, Current, Voltage, Power and Minimum and Maximum Cell Temperatures while charging Chevrolet Silverado EV. _____	130
Figure 5.43: FreeWire Boost Charger 200 replacement unit commissioning process at SpeedCharge HQ: (Left) operational interface, (Middle) unit in testing facility, (Right) technical specifications. _____	130
Figure 5.44: Modeled Calendar Aging of the Mountain View FreeWire Boost Charger 200 from 470 days of historical data. _____	133
Figure 5.45: Modeled Cyclic Aging of the Mountain View FreeWire Boost Charger 200 from 470 days of historical data. _____	133
Figure 5.46: Modeled total aging of the Mountain View FreeWire Boost Charger 200 extended to 30 years. Data is shown for different setpoints which describe the SOC which the unit will recharge up to after it has been depleted from a vehicle charging event. _____	134
Figure 5.47: Battery Expected Lifetime assuming end-of-life at 20% capacity loss (left) and percentage of charging provided at various SOC setpoints (right) by the Mountain View FreeWire Boost Charger 200. _____	135
Figure 5.48: Battery SOC for smart setpoint operation of the Mountain View FreeWire Boost Charger 200. _____	136
Figure 5.49: Battery expected lifetime assuming end-of-life at 20% capacity loss (left) and percentage of charging provided (right) based on the baseline and smart SOC policy used by the Mountain View FreeWire Boost Charger 200. _____	136

Figure A.1: EVES and EV SOC, Current, Voltage, Power, and Minimum and Maximum Battery Cell temperatures for charging session of Chevrolet Bolt by the EVES-6060-NA unit	146
Figure A.2: EVES and EV SOC, Current, Voltage, Power, and Minimum and Maximum Battery Cell temperatures for charging session of Chevrolet Bolt by the EVES-6060-NA unit	147
Figure A.3: EVES and EV SOC, Current, Voltage, Power, and Minimum and Maximum Battery Cell temperatures for charging session of Chevrolet Bolt by the EVES-6060-NA unit	147
Figure A.4: EVES and EV SOC, Current, Voltage, Power, and Minimum and Maximum Battery Cell temperatures for charging session of Chevrolet Bolt by the EVES-6060-NA unit	148
Figure A.5: EVES and EV SOC, Current, Voltage, Power, and Minimum and Maximum Battery Cell temperatures for charging session of Chevrolet Bolt by the EVES-6060-NA unit	148
Figure A.6: EVES and EV SOC, Current, Voltage, Power, and Minimum and Maximum Battery Cell temperatures for charging session of Chevrolet Bolt by the EVES-6060-NA unit	149
Figure A.7: EVES and EV SOC, Current, Voltage, Power, and Minimum and Maximum Battery Cell temperatures for charging session of Chevrolet Bolt by the EVES-6060-NA unit	149
Figure A.8: EVES and EV SOC, Current, Voltage, Power, and Minimum and Maximum Battery Cell temperatures for charging session of Chevrolet Bolt by the EVES-6060-NA unit	150
Figure A.9: EVES and EV SOC, Current, Voltage, Power, and Minimum and Maximum Battery Cell temperatures for charging session of Chevrolet Bolt by the EVES-6060-NA unit	150
Figure A.10: EVES and EV SOC, Current, Voltage, Power, and Minimum and Maximum Battery Cell temperatures for charging session of Chevrolet Silverado by the EVES-6060-NA unit	151
Figure A.11: EVES and EV SOC, Current, Voltage, Power, and Minimum and Maximum Battery Cell temperatures for charging session of Tesla Model Y by the EVES-6060-NA unit	151
Figure A.12: EVES and EV SOC, Current, Voltage, Power, and Minimum and Maximum Battery Cell temperatures for charging session of Tesla Model Y by the EVES-6060-NA unit	152
Figure A.13: EVES and EV SOC, Current, Voltage, Power, and Minimum and Maximum Battery Cell temperatures for charging session of Tesla Model Y by the EVES-6060-NA unit	152
Figure A.14: EVES and EV SOC, Current, Voltage, Power, and Minimum and Maximum Battery Cell temperatures for charging session of Volkswagen ID.4 by the EVES-6060-NA unit.	153

Figure A.15: EVES and EV SOC, Current, Voltage, Power, and Min and Max Battery Cell temperatures for charging session of Volkswagen ID.4 by the EVES-6060-NA unit _____	153
Figure A.16: EVES and EV SOC, Current, Voltage, Power, and Minimum and Maximum Battery Cell temperatures for charging session of Volkswagen ID.4 by the EVES-6060-NA unit _____	154
Figure A.17: EVES and EV SOC, Current, Voltage, Power, and Minimum and Maximum Battery Cell temperatures for charging session of Volkswagen ID.4 by the EVES-6060-NA unit _____	154
Figure A.18: EVES and EV SOC, Current, Voltage, Power, and Minimum and Maximum Battery Cell temperatures for charging session of Volkswagen ID.4 by the EVES-6060-NA unit _____	155
Figure A.19: SOC, Current, Voltage, Power, and Minimum and Maximum Battery Cell temperatures for charging session of EVES-6060-NA by 3-phase 480V AC power at ATIRC facility _____	156
Figure A.20: SOC, Current, Voltage, Power, and Minimum and Maximum Battery Cell temperatures for charging session of EVES-6060-NA by 3-phase 480V AC power at ATIRC facility _____	156
Figure A.21: SOC, Current, Voltage, Power, and Minimum and Maximum Battery Cell temperatures for charging session of EVES-6060-NA by 3-phase 480V AC power at ATIRC facility _____	157
Figure A.22: SOC, Current, Voltage, Power, and Minimum and Maximum Battery Cell temperatures for charging session of EVES-6060-NA by 3-phase 480V AC power at ATIRC facility _____	157
Figure A.23: SOC, Current, Voltage, Power, and Minimum and Maximum Battery Cell temperatures for charging session of EVES-6060-NA by 3-phase 480V AC power at ATIRC facility _____	158
Figure A.24: SOC, Current, Voltage, Power, and Minimum and Maximum Battery Cell temperatures for charging session of EVES-6060-NA at the Electrify America DCFC located at the Davis Bank of America _____	159
Figure A.25: SOC, Current, Voltage, Power, and Minimum and Maximum Battery Cell temperatures for charging session of EVES-6060-NA at the Electrify America DCFC located at the Davis Bank of America _____	159
Figure A.26: SOC, Current, Voltage, Power, and Minimum and Maximum Battery Cell temperatures for charging session of EVES-6060-NA at the Electrify America DCFC located at the Davis Bank of America _____	160
Figure A.27: SOC, Current, Voltage, Power, and Minimum and Maximum Battery Cell temperatures for a charging session of EVES-6060-NA by the Davis EVgo DCFC. _____	160
Figure A.28: SOC, Current, Voltage, Power, and Minimum and Maximum Battery Cell temperatures for a charging session of EVES-6060-NA by the Davis EVgo DCFC. _____	161

Figure A.29: SOC, Current, Voltage, Power, and Minimum and Maximum Battery Cell temperatures for a charging session of EVES-6060-NA by the Davis EVgo DCFC.	161
Figure A.30: SOC, Current, Voltage, Power, and Minimum and Maximum Battery Cell temperatures for a charging session of EVES-6060-NA by the Davis EVgo DCFC.	162
Figure A.31: SOC, Current, Voltage, Power, and Minimum and Maximum Battery Cell temperatures for charging session of EVES-6060-NA at the ChargePoint DCFC located in Emigrant Gap	162
Figure A.32: SOC, Current, Voltage, Power, and Minimum and Maximum Battery Cell temperatures for charging session of EVES-6060-NA at the ChargePoint DCFC located in Emigrant Gap	163
Figure A.33: SOC, Current, Voltage, Power, and Minimum and Maximum Battery Cell temperatures for charging session of EVES-6060-NA at the ChargePoint DCFC located in Emigrant Gap	163
Figure A.34: SOC, Current, Voltage, Power, and Minimum and Maximum Battery Cell temperatures for charging session of EVES-6060-NA at the ChargePoint DCFC located in Emigrant Gap	164
Figure A.35: SOC, Current, Voltage, Power, and Minimum and Maximum Battery Cell temperatures for charging session of EVES-6060-NA at the ChargePoint DCFC located in Emigrant Gap	164
Figure A.36: SOC, Current, Voltage, Power, and Minimum and Maximum Battery Cell temperatures for charging session of EVES-6060-NA at the ChargePoint DCFC located in Emigrant Gap	165
Figure B.1: Internal view of the EVES-6060-NA system, highlighting the master control switch, discharge switch, and start button	167
Figure B.2: Close-up of the master control switch panel, highlighting the master control switch (red arrow) and the START button (red circle), which must be activated to initiate system operation.	168
Figure B.3: Location and close-up view of the discharge switch, which must be flipped to the 'OFF' position before proceeding with the charging process.	168
Figure B.4: DC charging plug connection and AC grid input socket lid closure requirement.	169
Figure B.5: Charging status display on the EVES-6060 interface during operation.	170
Figure B.6: Turning the master control switch to 'OFF' before closing and locking the unit.	170
Figure B.7: Master control switch location for activating grid (AC) charging.	171
Figure B.8: START button activation and system status indicator for grid (AC) charging.	172
Figure B.9: Discharge switch location and activation for AC charging setup.	172

Figure B.10: Opening the AC power input lid for grid (AC) charging connection.	173
Figure B.11: Inserting and securing the 5-pin connector into the AC power input socket.	173
Figure B.12: Charging status display and indicator lights during AC charging operation.	174
Figure B.13: Master control switch location for initiating EV charging.	175
Figure B.14: START button and master control switch activation for EV charging.	175
Figure B.15: Activation of discharge switch for EV charging.	176
Figure B.16: Connecting the EVES-6060-NA charger to an EV	176
Figure C.1: Drawing for wiring of 7-pin connector for trailer plug	178
Figure D.1: Boost Charger 200 installed at Caltrans SOC, Current, Voltage, Power and Minimum and Maximum Cell Temperatures while charging Chevrolet Silverado EV.	179
Figure D.2: FreeWire Boost Charger 200 installed at Caltrans SOC, Current, Voltage, Power and Minimum and Maximum Cell Temperatures while charging Chevrolet Silverado EV.	180
Figure D.3: FreeWire Boost Charger 200 installed at Caltrans SOC, Current, Voltage, Power and Minimum and Maximum Cell Temperatures while charging Chevrolet Silverado EV.	180
Figure D.4: FreeWire Boost Charger 200 installed at Caltrans SOC, Current, Voltage, Power and Minimum and Maximum Cell Temperatures while charging Chevrolet Silverado EV.	181
Figure D.5: FreeWire Boost Charger 200 installed at Caltrans SOC, Current, Voltage, Power and Minimum and Maximum Cell Temperatures while charging Chevrolet Silverado EV.	181
Figure D.6: FreeWire Boost Charger 200 installed at Caltrans SOC, Current, Voltage, Power and Minimum and Maximum Cell Temperatures while charging Chevrolet Silverado EV.	182
Figure D.7: FreeWire Boost Charger 200 installed at Caltrans SOC, Current, Voltage, Power and Minimum and Maximum Cell Temperatures while charging Chevrolet Silverado EV.	182
Figure D.8: FreeWire Boost Charger 200 installed at Caltrans SOC, Current, Voltage, Power and Minimum and Maximum Cell Temperatures while charging Chevrolet Silverado EV.	183
Figure D.9: FreeWire Boost Charger 200 installed at Caltrans SOC, Current, Voltage, Power and Minimum and Maximum Cell Temperatures while charging Chevrolet Silverado EV.	183

# Tables

Table 2.1: Danner Mobile Costs and Lead Time	25
Table 2.2: EVESCO EVES Series Costs and Lead Time	25
Table 2.3: EVESCO EVMO Costs and Lead Time	26
Table 2.4: Portable Electric Voltstack 30k Costs and Lead Time	27
Table 2.5: FreeWire Costs and Lead Time	28
Table 2.6: Technical data of the EVESCO EVES-6060-NA	29
Table 2.7: Technical data of the FreeWire Boost Charger 200	31
Table 3.1: Procurement Timeline for EVESCO EVES-6060-NA	32
Table 3.2: List of desired parameters for EVES-6060-NA	39
Table 3.3: Candidate telemetry software and their available parameters	40
Table 3.4: Installation timeline for FreeWire Boost Charger 200	46
Table 3.5: Code description for indicator light-emitting diodes (LEDs) on Sierra Wireless MP70 [7]	50
Table 4.1: Parameters recorded during compatibility testing	54
Table 4.2: Compatibility between Caltrans' fleet EV's and the EVES-6060-NA.	54
Table 4.3: Session data for EVES-6060-NA charging Chevrolet Bolt.	56
Table 4.4: Session data for EVES-6060-NA charging Chevrolet Equinox.	58
Table 4.5: Session data for EVES-6060-NA charging Chevrolet Silverado EV.	61
Table 4.6: Session data for EVES-6060-NA charging Ford F150 Lightning.	63
Table 4.7: Session data for EVES-6060-NA charging Global M4 HSD.	65
Table 4.8: Session data for EVES-6060-NA charging Tesla Model 3.	67
Table 4.9: Session data for EVES-6060-NA charging Tesla Model S.	70
Table 4.10: Session data for EVES-6060-NA charging Tesla Model Y.	73
Table 4.11: Session data for EVES-6060-NA charging Volkswagen ID.4.	75
Table 4.12: Session data for EVES-6060-NA charging Volvo NRE62T.	77
Table 4.13: Statistics for Charging Sessions for 6 sample charging sessions of the EVES-6060-NA unit at the ATIRC facility with 480V AC power.	78
Table 4.14: Compatibility between EVES-6060-NA and other DCFCs	80
Table 4.15: Statistics for Charging Sessions of the EVES-6060-NA unit at the Electrify America DCFC located at the Davis Bank of America.	82
Table 4.16: Statistics for Charging Sessions of the EVES-6060-NA unit at the EVgo DCFC located in Davis.	84
Table 4.17: Statistics for Charging Sessions of the EVES-6060-NA unit at the ChargePoint DCFC located in Emigrant Gap.	87
Table 5.1: Charging specifications reported from FreeWire compared to historical usage data.	137

# Acronyms and Abbreviations

<b>Acronym</b>	<b>Definition</b>
AHMCT	Advanced Highway Maintenance and Construction Technology Research Center
AMP	Asset Management Platform
ATIRC	Advanced Transportation Infrastructure Research Center
BMS	Battery Management System
CAD	Computer-aided Design
Caltrans	California Department of Transportation
CCS1	Combined Charging System-1
DCFC	Direct Current Fast Charging
DOE	Division of Equipment
DOT	Department of Transportation
DRISI	Caltrans Division of Research, Innovation and System Information
HVAC	Heating, Ventilation, and Air Conditioning
IT	Information Technology
LED	Light-emitting Diode
LFP	Lithium Ferrophosphate (Lithium Iron Phosphate)
NACS	North American Charging Standard
NMC	Nickel Manganese Cobalt
OCPP	Open Charge Point Protocol
OCR	Optical Character Recognition
OSFM	Office of the State Fire Marshal
RFID	Radio Frequency Identification
SEI	Solid Electrolyte Interphase
SOC	State of Charge

<b>Acronym</b>	<b>Definition</b>
UCD	University of California, Davis
ZEV	Zero Emission Vehicle

# Acknowledgments

The authors gratefully thank the California Department of Transportation (Caltrans) for their valuable support, particularly Thai Van Nguyen, Abbas Pourheidari, Jeremy Matsu, and Robert Wedding with the Division of Transportation, and Hamid Ikram, Juan Araya, Mario Jaquiz, and Tawney Brennfleck with the Division of Research, Innovation, and System Information. The authors also sincerely acknowledge the dedicated and skilled efforts of the AHMCT team whose expertise and commitment have made this work possible.

# Chapter 1:

## Introduction

### Problem

The California Department of Transportation (Caltrans) is mandated to transition its fleet to zero-emission vehicles (ZEVs) in compliance with state regulations. Executive Order N-79-20, issued in 2020, requires that all new state fleet purchases be zero-emission by 2035 for light-duty vehicles and by 2045 for medium- and heavy-duty vehicles [1]. Additionally, the California Air Resources Board (CARB) introduced the Advanced Clean Fleets (ACF) regulation, mandating that manufacturers produce only ZEV trucks starting in 2036 [2].

The successful deployment of ZEVs is highly dependent on the availability of adequate charging infrastructure, which presents significant challenges for Caltrans operations:

- **Grid Constraints & Delayed Installations:** Many operational sites lack the electrical capacity to support high-power direct current fast charging (DCFC). Utility upgrades, such as transformer installations and substation expansions, can take months or even years, delaying fleet electrification [3].
- **Lengthy Permitting and High Installation Costs:** The installation of fixed DCFC stations often requires complex permitting approvals, which vary across California jurisdictions. In some cities, approvals can take a few days, while in others, they may take several months, which increases project expenses and duration [4].
- **Fleet Operational Disruptions:** Without sufficient charging infrastructure, Caltrans fleet operations risk vehicle downtime, limited range, and inefficient deployment, which will negatively affect maintenance, construction, and emergency response services [5].
- **Infrastructure Planning Uncertainty:** Fleet electrification requires long-term planning, yet factors, such as evolving vehicle technology, fluctuating energy demand, and changing regulations, introduce uncertainty in infrastructure investments, making fixed charging stations a potential financial risk if they become underutilized [6].

These barriers underscore the urgent need for a flexible, scalable, and cost-effective solution that can support fleet electrification while minimizing infrastructure deployment challenges.

## Objectives

The objective of this research is to assess the feasibility, operational effectiveness, and cost implications of mobile and semi-permanent DCFC infrastructure for Caltrans fleet operations. Given California's regulatory push toward fleet electrification and the challenges of deploying permanent grid-tied chargers, this study seeks to determine whether mobile DCFCs provide a viable alternative or complementary solution for Caltrans' electrification strategy.

## Scope

The scope of this research is to procure, test, and evaluate mobile and semi-permanent DCFC solutions for use in Caltrans fleet operations, ensuring that the selected solutions can support ZEV deployments while mitigating infrastructure deployment challenges.

## Research Methodology

The research included the following tasks:

- Task 1: Manage project
- Task 2: Obtain final specifications and candidate mobile or semi-permanent charging systems list from project panel, prioritize list
- Task 3: Procure sample systems
- Task 4: Document system installation and/or setup
- Task 5: Evaluate the applicability and feasibility of the systems
- Task 6: Develop final report

This research evaluated mobile and semi-permanent DCFC solutions to support Caltrans' fleet electrification, ensuring the feasibility, deployment efficiency, and operational effectiveness of these solutions. The study involved site preparation, system integration, and data monitoring to assess performance and compatibility with Caltrans' fleet needs.

## Overview of Research Results and Benefits

The product search for mobile and semi-permanent DCFC solutions is documented in Chapter 2, detailing the candidate systems' specifications and the selection criteria for chargers.

Chapter 3 covers system installation and setup, outlining site preparation, electrical infrastructure modifications, and deployment challenges for the EVESCO EVES-6060-NA (mobile charger) and FreeWire Boost Charger 200 (semi-permanent charger). The chapter also outlines key considerations, including permitting, panel upgrades, and connectivity integration.

The real-world performance evaluation of the chargers is presented in Chapters 4 and 5, where the EVESCO EVES-6060-NA and FreeWire Boost Charger 200 are assessed for vehicle compatibility, technical performance, and operational aspects. These chapters offer insights from charging tests, telemetry data analysis, and system performance metrics collected under normal, hot, and cold weather conditions.

Chapter 6 summarizes the key findings of the project, the challenges encountered, and the lessons learned.

# Chapter 2:

## Product Search for Mobile and Semi-Permanent DCFCs

The product search included a list of candidate systems received from Caltrans' Division of Equipment (DOE) and commercially available products identified by the AHMCT team. The following tasks detail the items addressed for this task:

- Obtain final specifications for the candidates' mobile or semi-permanent charging systems from the project panel.
- Prioritize the list based on meeting DOE specifications and the available budget.
- Present the finalized list along with candidates' technical details and the pros and cons of each system to the panel. Identify a subset of systems for procurement based on the panel's indications and the available budget.

The AHMCT team was provided with a list of sixteen (16) candidate DCFCs from eight (8) manufacturers. Given the project timeline, the AHMCT team collected both purchase prices and rental rates, when available, for each unit. Additionally, the AHMCT team requested information on equipment lead times, vendor training, maintenance requirements, and included services. The manufacturers, purchase prices, rental prices, maintenance costs, and lead time for each unit considered are described in the following sections.

### **Dannar Mobile**

The Dannar Mobile 4.00 was considered for evaluation due to its desirable technical specifications and mobility. The unit features a modular platform that supports various heavy equipment and charging attachments. The platform has an onboard battery capable of delivering and receiving level 2 and level 3 electronic vehicle (EV) charging. The project panel considered the 504 kWh and 375 kWh battery options for the unit. The unit is equipped with full-time 4x4 electric drive with a maximum speed of 20 mph. Although it must be towed when traveling long distances, the unit can also be operated via remote control, allowing for ease of transportation at worksites. These features would allow for EV charging at remote worksites, fulfilling a critical use case.

**Table 2.1: Dannar Mobile Costs and Lead Time**

Model	Purchase Price (\$)	Rental Price (\$)	Maximum Power (kW)	Maximum Capacity (kWh)	Lead Time
<b>4.00 (500 kWh)</b>	465,950	N/A (rental unavailable)	Level 3 (exact charging power not specified.)	504 or 375	1 year

## EVESCO EVES Series

The EVESCO EVES series was considered as a candidate system due to its charging characteristics, price, and mobility. The model is offered in three power and energy configurations:

- 120 kWh capacity, 120 kW charging power.
- 60 kWh capacity, 60 kW charging power.
- 30 kWh capacity, 30 kW charging power.

The units can provide DC fast charging and can be charged by DCFCs or 480V 3-phased AC chargers. They are also fully portable and do not require a connection to grid for operation. Ultimately, the EVES-6060-NA was one of two chargers selected for evaluation. This charger will be explored in greater depth in the EVESCO EVES-6060-NA section.

**Table 2.2: EVESCO EVES Series Costs and Lead Time**

Model	Purchase Price (\$)	Rental Price (\$)	Maximum Power (kW)	Maximum Capacity (kWh)	Lead Time
<b>EVES-120120-NA</b>	149,305	N/A (only financing available)	120	120	~3 months
<b>EVES-6060-NA</b>	80,112	N/A (only financing available)	60	60	~3 months

Model	Purchase Price (\$)	Rental Price (\$)	Maximum Power (kW)	Maximum Capacity (kWh)	Lead Time
<b>EVES-3030-NA</b>	43,935	N/A (only financing available)	30	30	~3 months

## EVESCO EVMO Series

In addition to the EVES-6060-NA series, the EVESCO EVMO series chargers were also considered. Although these units are lower in price, they do not have energy storage capabilities; namely, the system converts AC to DC, then directly delivers power to the recipient EV. Both units can deliver charge at 60 kW DC and have different input power requirements depending on the model:

- EVMO-60-S: minimum 3-phase 305 Vac power
- EVMO-60-208: minimum 3-phase 208 Vac power

Full portability was a critical requirement for the selected charging system. Since the EVMO series chargers require a permanent grid connection, they were not considered further after their presentation to the panel.

**Table 2.3: EVESCO EVMO Costs and Lead Time**

Model	Purchase Price (\$)	Rental Price (\$)	Maximum Power (kW)	Maximum Capacity (kWh)	Lead Time
<b>EVMO-60 (208V)</b>	16,532	N/A (only financing available)	60	N/A	~3 months
<b>EVMO-60 (S)</b>	13,290	N/A (only financing available)	60	N/A	~3 months

## Lightning e-Motors Lightning Mobile Series

The Lightning e-Motors Lightning Mobile series chargers were considered due to their charging power, portability, and number of charging outputs. The Lightning Mobile series chargers are available in the following configurations:

- 275 kWh capacity, 80 kW charging power.
- 420 kWh capacity, 80 kW charging power.

The chargers are preinstalled on a tandem axle trailer, allowing for ease of transportation. Up to five (5) outputs can be requested for the system, allowing for greater efficiency when charging multiple vehicles. The chargers are also equipped with a CCS1 port and can accept level 3 charging from DCFCs. The vendor did not reply to inquiries by the AHMCT team. Therefore, the project panel did not select the Lightning Mobile Series for procurement.

## Portable Electric Voltstack 30k

The Portable Electric Voltstack 30k was considered against the EVESCO EVES-6060-NA due to their comparable charging characteristics. The system has a maximum capacity of 80 kWh but can only charge at a maximum power of 27 kW. Like the EVES-6060-NA, the Voltstack 30k accepts level 3 charging and does not require a permanent connection to the grid. A trailer is also available from the vendor upon request. However, due to its higher price and comparable charging characteristics to the EVES-6060-NA, the Voltstack was not selected for procurement by the project panel.

**Table 2.4: Portable Electric Voltstack 30k Costs and Lead Time**

Model	Purchase Price (\$)	Rental Price (\$)	Maximum Power (kW)	Maximum Capacity (kWh)	Lead Time
<b>Voltstack 30k</b>	\$205,355	\$166,952/year	27	80	2 months

## XOS Energy Solutions

The XOS Hub and XOS 30 kW Portable Charger were considered due to their charging characteristics and mobility. The XOS hub is a truck-mounted charger that can deliver charges up to 160 kW, with a maximum capacity of 280 kWh. The XOS 30 kW Portable Charger is a mobile charging station with a maximum power of 30 kW (options of up to 160 kW were available) with a maximum capacity of 280 kWh.

The AHMCT team made several attempts to contact XOS during the procurement phase of the project but did not receive a reply. As such, the XOS Hub and XOS 30 kW Portable Charger were not selected for procurement.

# FreeWire

The FreeWire Boost Charger 200 was considered as a candidate system due to its high charging power, battery-integrated design, and flexible deployment. The model utilizes a 160-kWh battery capacity and has a maximum charging power of 200 kW. It supports dual charging, allowing two vehicles to charge simultaneously at up to 100 kW each. The unit is also compatible with CCS1, CCS2, and CHAdeMO connectors and operates with an input power of  $\leq 27$  kW from a low-voltage grid connection.

**Table 2.5: FreeWire Costs and Lead Time**

Model	Purchase Price (\$)	Rental Price (\$)	Maximum Power (kW)	Maximum Capacity (kWh)	Lead Time
<b>Boost Charger 200</b> <b>Boost Charger 200</b>	137,740	N/A (rental unavailable)	200	160	~3 months

Unlike traditional fast chargers, the Boost Charger 200 buffers energy from the grid, reducing demand charges and installation costs. Ultimately, the Boost Charger 200 was one of the chargers selected for evaluation by the panel. This charger will be explored in greater depth in the FreeWire Boost Charger 200 section.

The FreeWire Mobi EV Charger was also considered as a candidate system due to its mobility and ease of deployment. The Mobi EV charger does not require fixed infrastructure and can be moved to wherever EVs are parked. The unit features an 80-kWh battery capacity and delivers up to 11 kW of continuous power through dual SAE J1772 connectors, allowing for level 2 charging for two vehicles simultaneously. It can be recharged using standard 240 V outlets or other EV charging stations. Due to its low charging power and comparable dimensions/mass to the EVES-6060-NA, the Mobi EV Charger was not selected for evaluation.

The AHMCT team primarily weighed technical specifications, lead time, and cost when making recommendations to the panel. The technical specification considered included charging rate (power), battery capacity, dimensions, and mobility. Service options provided by each of the manufacturers, such as warranty, commissioning services, and technical support services, were also variables impacting the decision about which system to purchase. Considering all the above factors and the project budget, the panel selected two options

for procurement: the EVESCO EVES-6060-NA and the FreeWire Boost Charger 200. More information about these systems is provided below.

## Specifications of selected units:

### EVESCO EVES-6060-NA

The EVESCO EVES-6060-NA is a mobile DCFC station that was selected due to its capacity, charging power, price, and portability. The EVESCO EVES-6060-NA offers balanced performance characteristics that align with Caltrans' requirements and use cases. Furthermore, the EVES-6060-NA was one of the few solutions that could accept both level 3 fast charging through DC input power (CCS1) and level 2 charging via AC input power. Thus, the AHMCT team and the panel opted to purchase one (1) EVES-6060-NA with CCS1 and North American Charging Standard (NACS) output adapters.

Technical data for the EVES-6060-NA are presented in Table 2.6.

**Table 2.6: Technical data of the EVESCO EVES-6060-NA**

Parameter	Value
Dimensions (W x L x H)	50.4 x 63x 48 in (1280 x 1600 x 1220) mm
Weight	~950 kg (2094lbs)
Cell Type	LFP
Storage Capacity	60 kWh
Charging Outlet	CHAdEMO, CCS1, CCS2, GB/T
Output Power	60 kW
Output Voltage	200 - 920 Vdc
Input Voltage	480 V AC DCFC: CCS1, CCS2, CHAdEMO, NACS (CCS1 and NACS was chosen for the unit acquired.)
Cable Length	5 m (16.4 feet) as standard

Parameter	Value
Connectivity	RS485, CAN, LAN
Operating Temp.	Discharge: -4°F to 149°F (-20°C to 65°C) Charge: -4°F to 131°F (-20°C to 55°C)

As can be observed in Table 2.6, the EVES-6060-NA has several options for outgoing and incoming charge. The unit also has a wide operating temperature range, allowing for deployment in worksites with harsh weather conditions.

Caveats of the unit include its AC input voltage requirements and the absence of built-in portability features. The unit requires 480 V AC when charging from the grid. Notably, 480 V AC power may not be available at all worksites in which the EVES-6060-NA will be deployed. Charging via AC also requires installation of a special cable and adapter. Unless a worksite has access to 480 V AC power and the necessary cables and adapters installed, operators must charge the unit using an external DCFC. Furthermore, the EVES-6060-NA does not include an integrated trailer. Thus, a truck or a trailer is necessary to transport the unit.

## *FreeWire Boost Charger 200*

The FreeWire Boost Charger 200 is a semi-permanent DCFC station selected for its feasibility as a long-term solution to Caltrans' charging needs. A key consideration was the charging power of the unit; the FreeWire Boost Charger 200 can deliver DC charging at a rate of 200 kW and has a built-in 160 kWh battery. The unit's internal battery is continuously charged, enabling on-demand DC fast charging without requiring high-voltage power. In fact, the FreeWire Boost Charger 200 accepts 208 V or 240 V power input. This feature will facilitate charging for vehicles in Caltrans' fleet whose deployments are time sensitive, such as the Global M4 HSD.

Unlike the EVES-6060-NA, the FreeWire Boost Charger 200 is designed for stationary use. Its primary function is to charge Caltrans' fleet EVs at maintenance stations with permanent power connections and foundations. The FreeWire Boost Charger 200 does not accept DC fast charging and can only be charged at locations where the required conduit and footing have been installed.

The technical data for this charger are listed in Table 2.7.

**Table 2.7: Technical data of the FreeWire Boost Charger 200**

Parameter	Value
Dimensions (W x L x H)	43 x 40 x 96 in (1090 x 1010 x 2430 mm)
Weight	~1720 kg (3800 lbs.)
Cell Type	NMC
Energy Storage	160 kWh
Supported Connector	CHAdeMO, CCS1, CCS2, NACS and GB/T (CCS1 was selected for Caltrans' unit.)
Charging Ports	2
Max Output Power	CCS1: 200 kW CHAdeMO: 100 kW Combined: charge two (2) vehicles simultaneously at up to 100 kW each
Output Voltage	200-950 VDC
Input Power	27 kW
Input Voltage	208V AC: 80 A continuous, or 240V AC: 120 A continuous
Cable Reach	134", (3.4 m)
Connectivity	4G, Ethernet
Operating Temp.	-20°C to 55°C (-4°F to 131°F)

# Chapter 3: System Installation and Setup

The AHMCT team placed purchase orders for one (1) EVESCO EVES-6060-NA and one (1) FreeWire Boost Charger 200. The purchase order for the EVES-6060-NA was placed in December 2023. The purchase order for the FreeWire Boost Charger 200 was placed in March 2024.

## EVESCO EVES-6060-NA

### *Procurement Timeline*

The EVESCO EVES-6060-NA was received by the AHMCT team on August 30, 2024, at the Advanced Transportation Infrastructure Research Center (ATIRC) facility. Due to challenges in manufacturing and shipping, the EVES-6060-NA was delivered five months later than the scheduled date. Table 3.1 shows a timeline of the unit's shipment based on online communications with EVESCO.

**Table 3.1: Procurement Timeline for EVESCO EVES-6060-NA**

Date	Event
<b>12/5/2024</b>	AHMCT team placed purchase order for EVESCO EVES-6060-NA.
<b>2/27/2024</b>	AHMCT team requested a revised quote for overcharge on charging cables.
<b>3/8/2024</b>	UC Davis issued 60% payment for EVES-6060-NA.
<b>3/15/2024</b>	EVESCO received 60% payment for EVES-6060-NA.
<b>3/27/2024 (Original expected delivery date)</b>	AHMCT team was informed that EVES-6060-NA was at Port of Oakland awaiting shipment to AHMCT facility. AHMCT team was later informed that the unit still required four weeks of manufacturing time and would not be

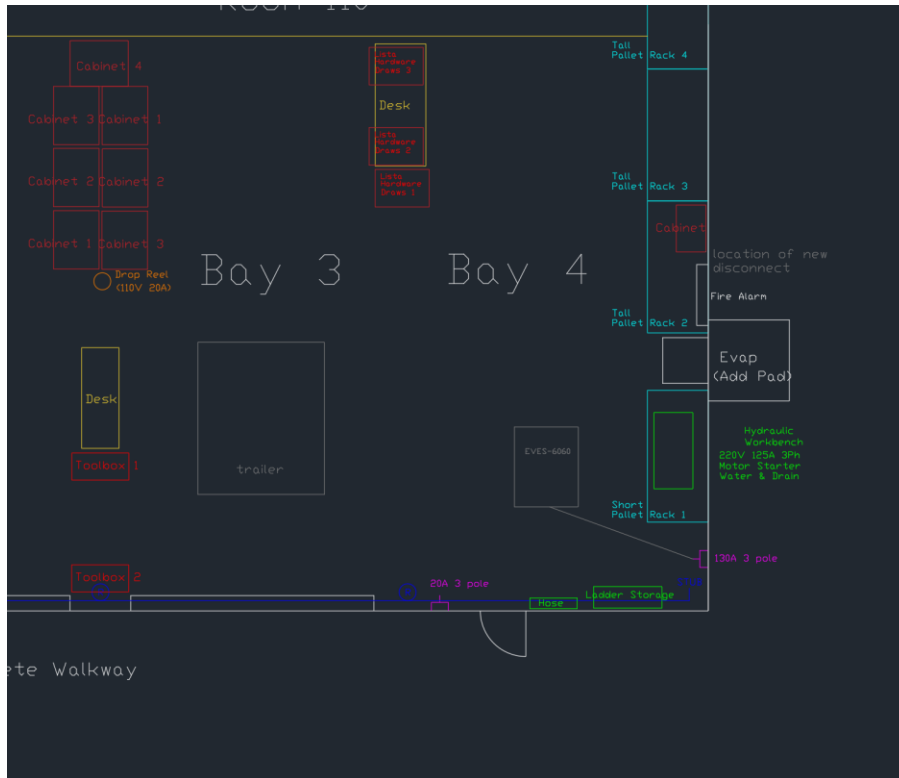
Date	Event
	delivered until 14 weeks later (the week of July 1, 2024).
<b>4/15/2024</b>	EVESCO informed the team that the unit had been manufactured and would arrive at EVESCO warehouse in 8 weeks (the week of June 10, 2024).
<b>7/10/2024</b>	EVESCO informed the team that the unit was shipped via boat and slated to arrive at their Reno warehouse on August 5, 2024.
<b>8/28/2024</b>	EVESCO shipped EVES-6060-NA to AHMCT facility from their Reno warehouse.
<b>8/30/2024</b>	AHMCT team received unit at their facility.

Although these delays significantly skewed the timeline of the project, the AHMCT team made efforts to expedite the shipment of the EVES-6060-NA to ATIRC and to proceed with the research. The team was able to complete several tasks in the months before the unit was delivered as described in the following sections.

### *ATIRC 480 V Panel Modifications*

ATIRC is equipped with a preexisting three-phase, 480 V electrical panel, located on the eastern wall of the building. Modifications to this panel were required to facilitate on-grid AC charging for the EVES-6060-NA, specifically:

- Installation of a 100-amp breaker
- Installation of a two-way shutdown switch
- Installation of EVESCO-specific charging cable to 100-amp breaker



**Figure 3.1: ATIRC layout with EVES-6060-NA positioned for direct breaker access**

The installations were completed in October 2024. The AHMCT team was able to complete the planned number of charging tests with the AC input. The results of this testing are outlined in Chapter 4.

## Trailer Procurement

The project panel requested a designated trailer for transporting EVES-6060-NA. One of Caltrans' equipment engineers involved with the project was contacted to obtain the required specifications for the trailer:

- **The trailer shall be equipped with hydraulic surge brakes.** This feature will allow vehicles without electronic brake controllers to use the brakes installed on the trailer.
- **The trailer shall be equipped with a lunette towing eye.** The lunette towing eye is standard for Caltrans, eliminating the need to stock multiple sizes of ball hitches.
- **The trailer shall have a tandem axle configuration.** Tandem axle configurations are superior in handling compared to single axle configurations.

- **The trailer shall be in a deck over configuration.** This configuration will allow the unit to be placed on the trailer using a forklift.
- **The trailer shall be compatible with a 7-pin connector specifically used with Caltrans' fleet vehicles** (See Appendix C.)



**Figure 3.2: Zieman 1166-S Flat Deck Type trailer at ATIRC**

The specifications of the trailer were finalized by the project panel, and a trailer was purchased from Zieman trailers that met the following specifications:

- Zieman 1166-S Flat Deck Type
- 12 ft deck
- Surge brakes with parking brake drums and parking brake activation
- 3 in inner diameter lunette towing eye
- Spring-loaded jack
- Custom lighting
- Wheel chucks with holders
- Mudflaps

A purchase order for the trailer was placed on June 6, 2024. The trailer arrived at ATIRC on September 11, 2024.

# System Setup

The EVESCO EVES-6060-NA was delivered disassembled (see Figure 3.3). The shipment included the following items:

- One (1) EVES-6060-NA chassis
- Eight (8) battery modules
- Seven (7) communication cables
- Seven (7) power connection cables
- Hardware for mounting battery modules
- Hardware for electrical connections
- Two (2) keys for opening and locking unit doors
- Two (2) radio frequency identification (RFID) cards



**Figure 3.3: Shipment of EVES-6060-NA to ATIRC**

Assembling the EVES-6060-NA required high voltage training. Therefore, the work was completed by experts from UC Davis Facilities. As shown in Figure 3.4, each battery module is mounted in dedicated racks within the chassis, connected by the provided wiring harnesses. The detailed assembly procedure is:

1. Unpack EVES-6060-NA and battery modules.
2. Open rear doors using keys.
3. Using an electric lift or forklift with straps, place all eight (8) battery modules into the racks in the rear of the unit. The AHMCT team placed the modules in increasing order from left to right, starting at the top of the unit.
4. Fasten each module using the hardware provided.

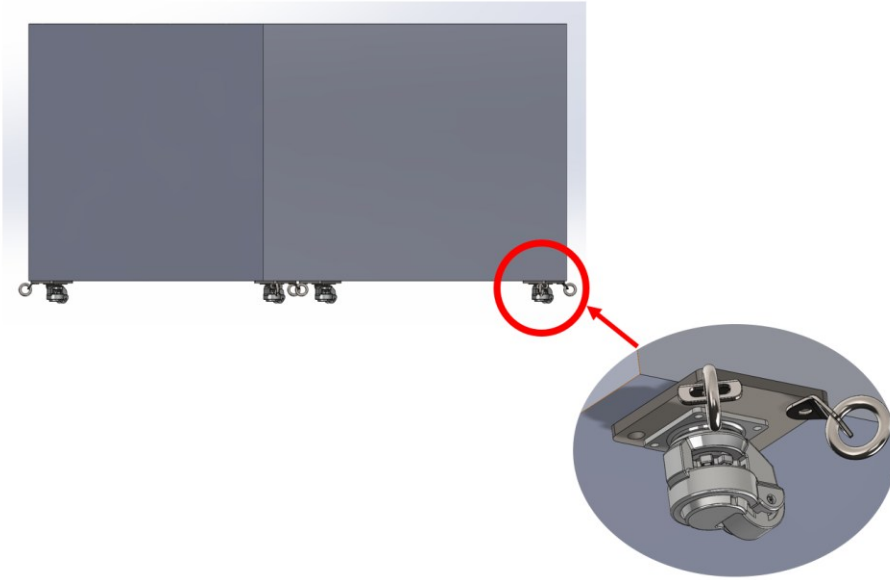
5. Connect communication ports using provided ethernet cables. Each cable is marked with "COM1" or "COM2," indicating which port into which each cable should be inserted.
6. Make power connections to each module using cables and provided hardware.
7. The setup is complete. Leave the unit's doors closed during operation.



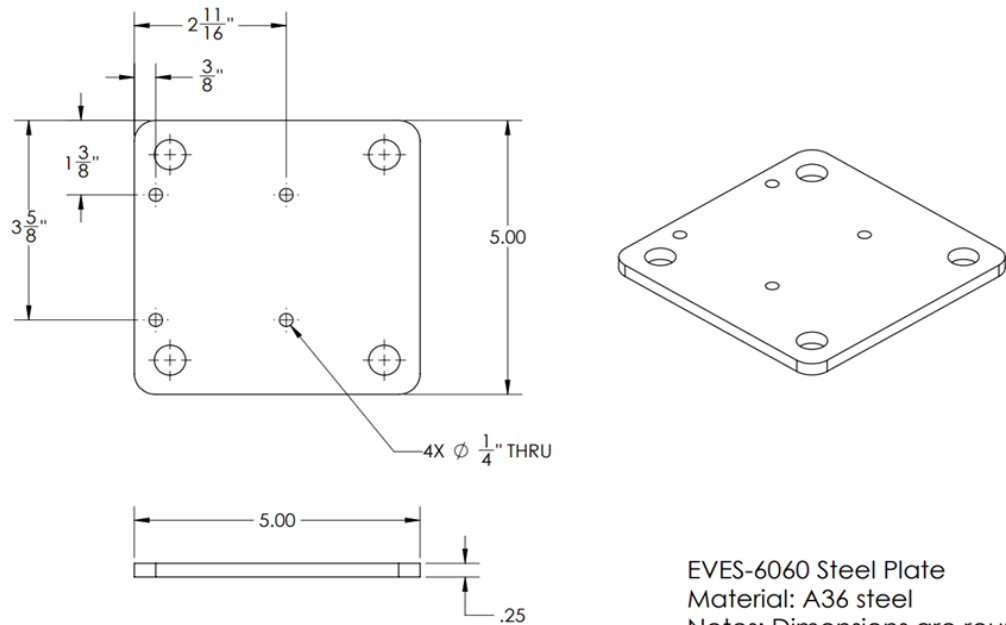
**Figure 3.4: EVES-6060-NA interior and battery modules mounted**

After the power connections were complete, the communication ports were connected, and the EVES-6060-NA was powered on successfully. The unit successfully charged a Volkswagen ID.4, verifying proper functionality of the CCS1 port.

To confirm the ability of the system to accept charges via DCFC, the unit was transported to an off-campus DCFC location. Some modifications to the system were necessary for safe transportation. The EVES-6060-NA was not designed with tie-down points for ratchet straps, complicating transportation using a truck or trailer. The AHMCT team designed a plate that allows for fixing the unit onto a truck or trailer, preventing lateral, longitudinal, and vertical displacement during transportation. The design can be seen in Figures 3.5 and 3.6. The design is compatible with the preexisting holes and hardware equipped on the unit. Figures 3.5 and 3.6 show the solution as modeled in the SOLIDWORKS computer-aided design (CAD) software.



**Figure 3.5: Mounting solution for attaching EVES-6060-NA to truck or trailer**



**Figure 3.6: SOLIDWORKS drawing of mounting plate**



**Figure 3.7: Mounting solution for attaching EVES-6060-NA to truck (including ratchet straps)**

The EVES-6060-NA was charged with an Electrify America DCFC station, confirming that the unit can be successfully charged via DC power. Detailed testing results and conclusions for the EVES-6060-NA can be found in Chapter 4.

## Data Acquisition

The AHMCT team aimed to obtain quantitative data from the EVES-6060-NA to evaluate its performance. Efforts to research and purchase a telemetry software began while the unit was being shipped. The panel and the AHMCT team created a list of desired parameters, which are listed in Table 3.2.

**Table 3.2: List of desired parameters for EVES-6060-NA**

Parameter (EVES-6060-NA)	Units
Battery temperature (highest and lowest cell)	Degrees Celsius
SOC (State of Charge)	Percent

Parameter (EVES-6060-NA)	Units
Power	Kilowatts
Energy	Kilowatt-Hours
Voltage	Volts
Current	Amperes
Time stamps for each measurement	Month/Day/Year, Hours:Minutes:Seconds

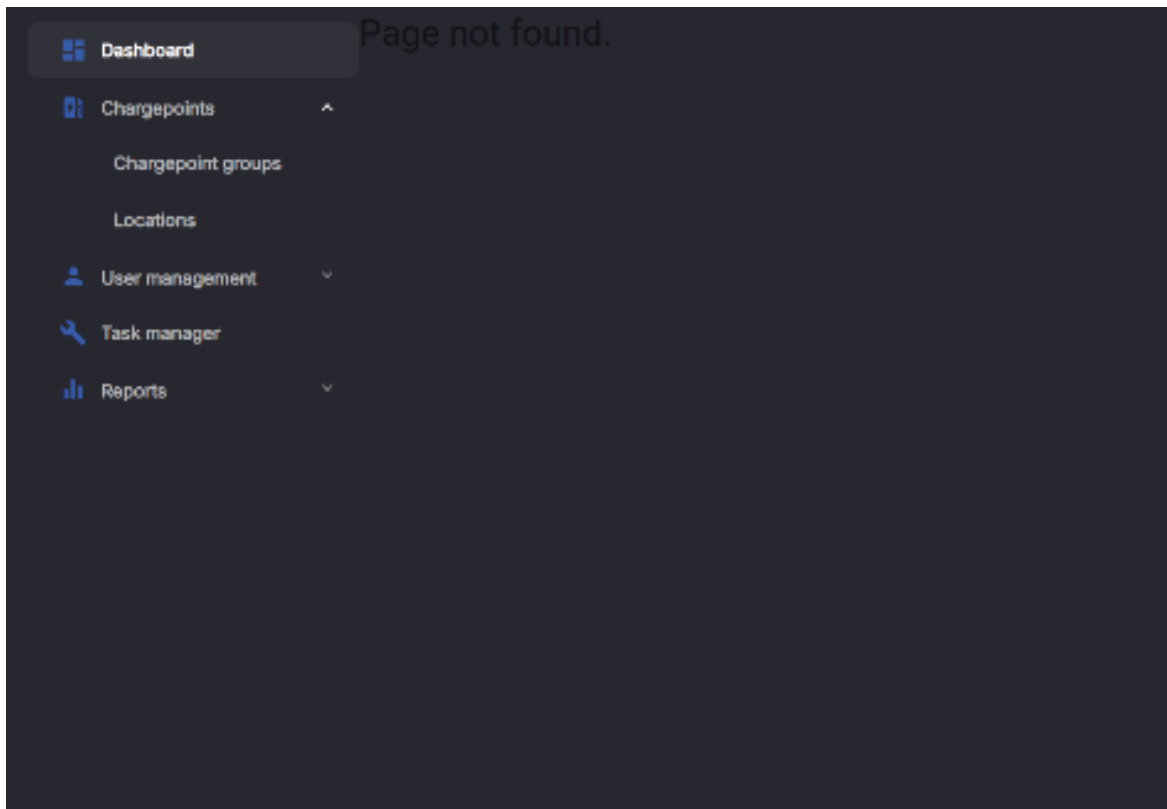
The AHMCT team's search for suitable telemetry software indicated that most available options were intended for fleet management and commercial applications. Table 3.3. lists the software considered and their available parameters.

**Table 3.3: Candidate telemetry software and their available parameters**

Software	Parameters Available
<b>ChargePoint Cloud Software</b>	<ul style="list-style-type: none"> <li>• Station status</li> <li>• Power (MW)</li> <li>• Station usage</li> <li>• Number of unique drivers</li> <li>• Number of charging sessions</li> <li>• Average session length</li> <li>• Income and utility costs</li> </ul> <p>Service was unavailable for the EVES-6060-NA</p>
<b>ChargeHQ</b>	<ul style="list-style-type: none"> <li>• Start time</li> <li>• Energy delivered from EVES-6060-NA per session (kWh)</li> </ul>
<b>ChargeMetric (EVESCO's software)</b>	<ul style="list-style-type: none"> <li>• Charge date</li> <li>• Energy delivered from EVES-6060-NA per session (kWh)</li> </ul>

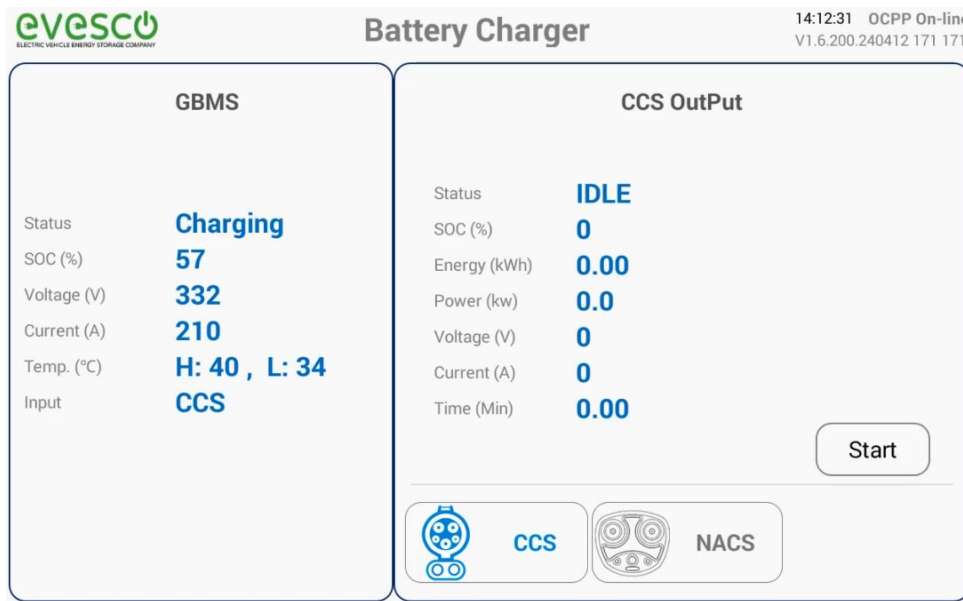
The software systems ChargeMetric and ChargeHQ did not provide all the data necessary for the system evaluation; these programs only provided the delivered energy per charging session. Although it was reported that ChargePoint is capable of logging detailed telemetry data at the granularity desired by the AHMCT team, these data were inaccessible. Despite several attempts to access these data, the site consistently showed a blank screen that read, “Page Not Found,” as can be seen in Figure 3.8. Although the AHMCT team was in communication with EVESCO, a solution to this problem was not identified.

Efforts were also made to acquire these data directly from the unit. The AHMCT team checked the internal files of the EVES-6060-NA to ascertain whether data were tabulated in log files. Although metrics, such as power delivery and session time, are recorded for each charging session, the data are not collected with the level of granularity required for the AHMCT team’s research. (Data must be collected at a frequency of about 1 HZ.) Critical metrics, such as maximum and minimum cell temperature, were also not logged.

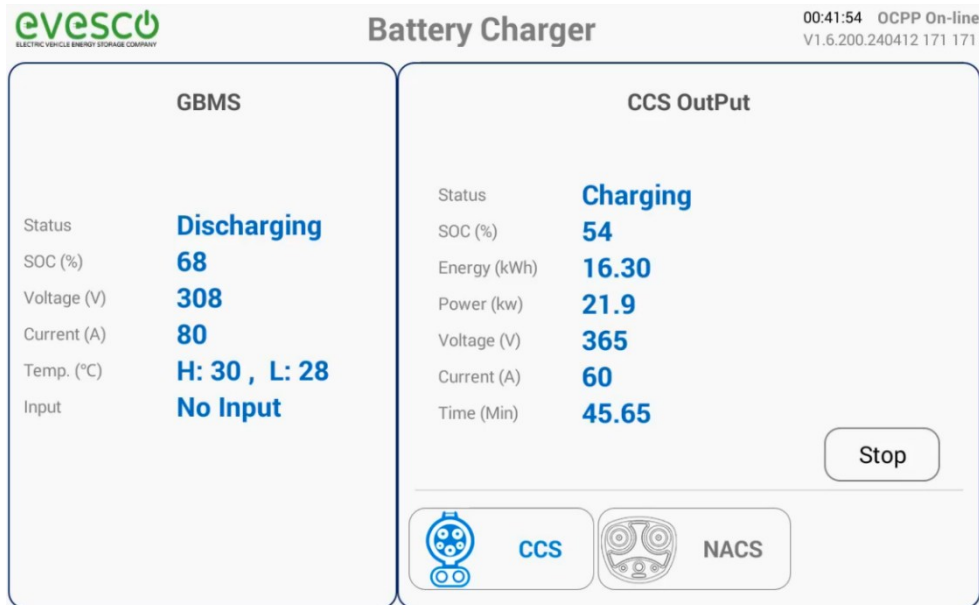


**Figure 3.8: “Page Not Found” screen shown when trying to access telemetry data from ChargeMetric**

With failed attempts while logging telemetry data from the EVES-6060-NA, the research team designed a method using Python scripts for acquiring the data listed in Table 3.2 during experiments. The required data are shown on the EVES-6060-NA small screen, and the system runs on an Android Operating System, which allows screen recording. It was determined that recording the front display of EVES-6060-NA during experiments and using a Python script to digitize and tabulate the shown data is the best path forward for data collection. Figures 3.9 and 3.10 show the data displayed when charging and discharging the unit.



**Figure 3.9: Screenshot of screen recording from front display of EVES-6060-NA (during charging)**



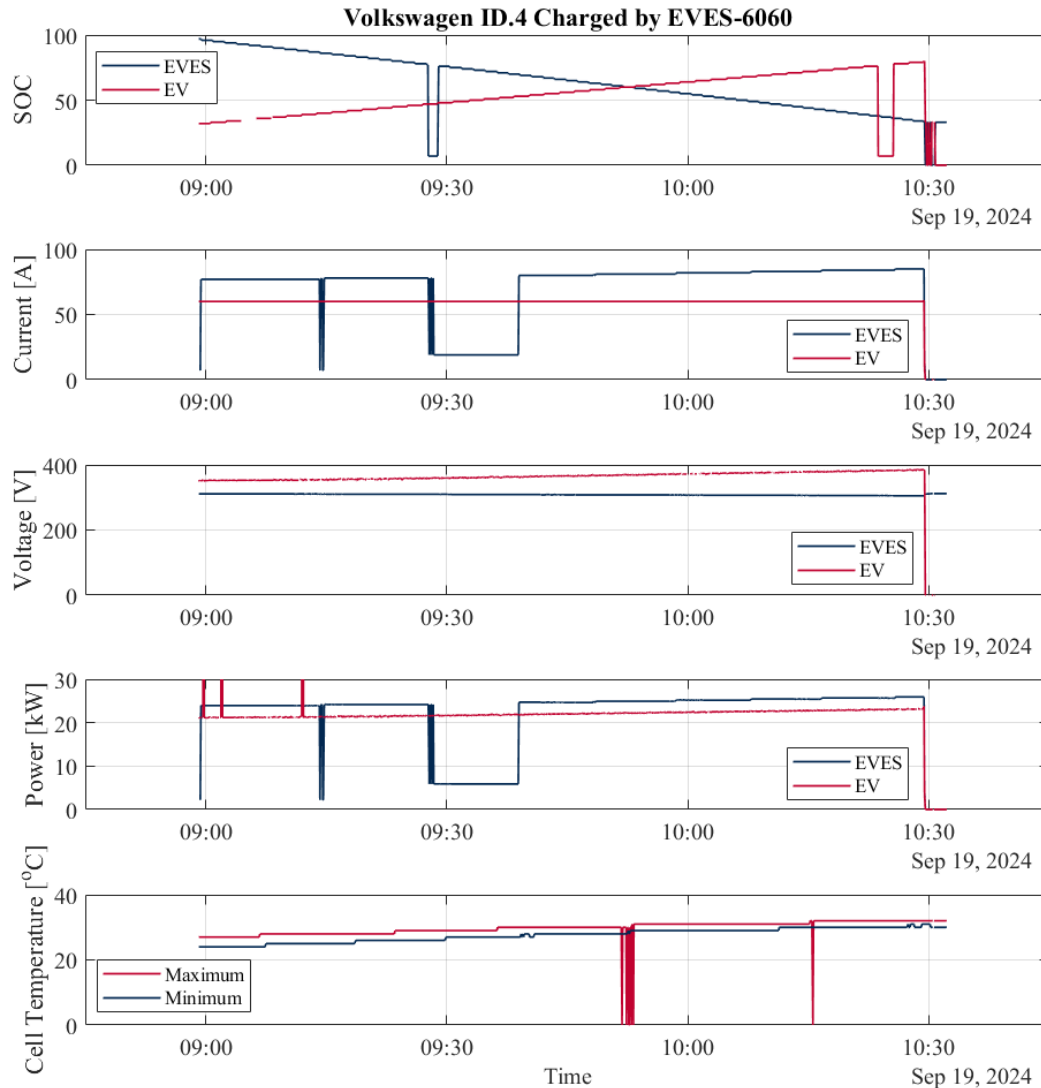
**Figure 3.10: Screenshot of screen recording from front display of EVES-6060-NA (during discharging)**

The developed Python script utilizes Tesseract, an OCR function, to select frames from a screen recording at intervals of 20 seconds. The frames are split into sections which each contain a specific variable. The text from these frames is extracted then sorted into a .csv file for processing. Figure 3.11 shows this process.



**Figure 3.11: Flow of outputs from scripts ending in data table in .csv format**

Figure 3.12 shows the charger/vehicle current, voltage, SOC, and cell temperature of the unit against time while charging a Volkswagen ID.4. Plots for data acquired for future sessions are presented in Chapter 4.



**Figure 3.12: Current, Voltage, and SOC for EV and the EVES-6060-NA charger, along with the High and Low Cell Temperature from a Sample Charging of a Volkswagen ID.4. The data acquired through recording the screen of the EVES-6060-NA.**

As can be seen in Figure 3.12, the plots show some outliers due to occasional misreading of the text from images. These outliers can be removed by postprocessing the resulting .csv data table.

In preparation for cloud-based telemetry software, the AHMCT team implemented a Sierra Wireless MP70 cellular modem to provide Wi-Fi capabilities for the EVES-6060-NA in remote areas. The AHMCT team found that the modem was necessary to initiate charging sessions between the EVES-6060-NA and recipient EVs. (Details can be found in Chapter 4.)

# *EVES-6060-NA Operating Manual*

The AHMCT team developed an operating manual for the EVES-6060-NA to provide guidance on using the unit. This manual offers detailed instructions on startup, operation, and shutdown procedures, along with step-by-step guidelines for charging the unit from an AC power source, using a DCFC, and charging an EV with the unit. This manual can be found in Appendix B of this report.

## **FreeWire Boost Charger 200**

AHMCT acquired a FreeWire Boost Charger 200 in June 2024. After several challenges, the unit was installed at the Magana Ortega Maintenance Station. The delays in the procurement and installation of the FreeWire Boost Charger 200 were attributed to the following factors:

1. Long process associated with obtaining a permit from the Office of the State Fire Marshal (OSFM).
2. FreeWire ceased operations in May 2024. There was a period of transition as SpeedCharge began providing support and commissioning services for the Boost Charger 200.

The evaluation of the Boost Charger 200 was able to proceed by obtaining data from other FreeWire Boost Charger 200 installations. Operational data were acquired by collaborating with UC Davis Fleet Services and FreeWire. UC Davis Fleet services installed a FreeWire Boost Charger 200 in May 2024. This unit was monitored for six months during this project, and its operational data were collected for detailed evaluation. Furthermore, SpeedCharge provided data from two of their prior FreeWire Boost Charger 200 installations in Mountain View and Morgan Hill. These data are explored in detail in Chapter 5.

## *System Setup*

Commissioning for the FreeWire Boost Charger 200 was completed on February 18, 2025 (see Figure 3.13). This process included trenching, installation of the main conduit, and installation of concrete and metal footing for the unit. The items listed in Table 3.4 were completed by Caltrans' team during December 2024 and January 2025.

**Table 3.4: Installation timeline for FreeWire Boost Charger 200**

Date	Event
11/6/2024	Received permit from OSFM.
1/2/25	Finished underground conduit.
1/3/2025	Submitted email/photo to OSFM for approval to proceed.
1/8/2025	Passed OSFM field inspection.
1/11/2025	Slurry 7" conduit installed.
1/18/2025	Concrete pour and native soil backfill placed.
1/25/2025	Wires pulled. Ready to energize.
2/18/2025	Final commissioning



**Figure 3.13: Photos showing final commissioning of FreeWire Boost Charger 200**

The final commissioning of the FreeWire Boost Charger 200 included the following:

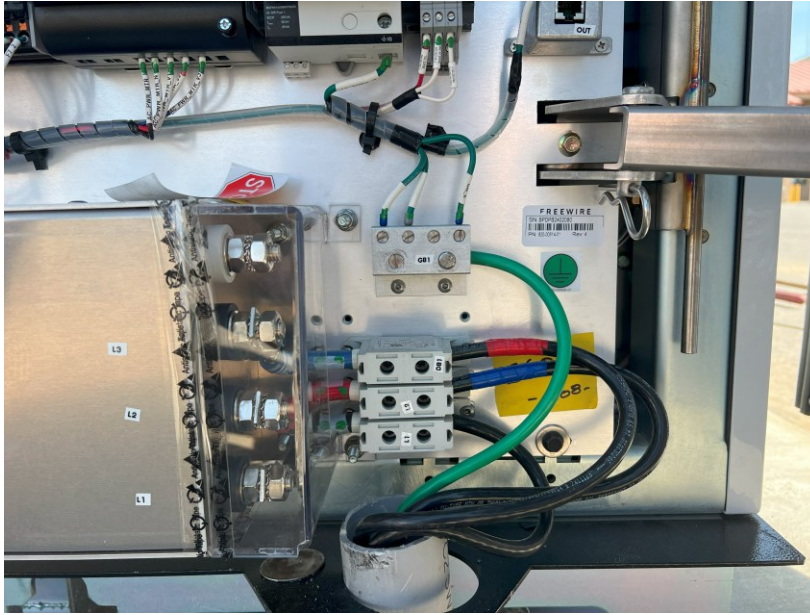
1. Final power connections from unit to grid were made
2. 100 A breaker installed
3. Protective rails installed
4. Software installed on unit
5. Wireless modem set up
6. Several test charges completed

The final power connections involved running underground conduit from the central building's panel to the unit (see Figure 3.14). The conduit was connected to a 100 A breaker installed behind the FreeWire Boost Charger 200:



**Figure 3.14: Photos showing panel installed behind FreeWire Boost Charger 200 and protective rails**

Rails were installed next to the panel to protect it in the event of a vehicle collision (see Figure 3.14). The cables were then run to the front of the unit, where the final wire terminations were made.



**Figure 3.15: Main conduit wiring terminations on the front of FreeWire Boost Charger 200**

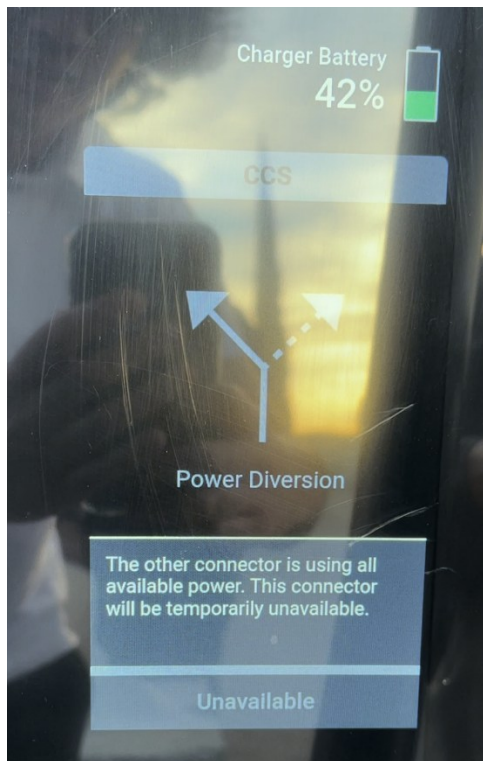
After power was supplied to the unit, wireless connections were verified (see the “FreeWire Boost Charger 200 Internet Connectivity” section) and the necessary software package was installed. Several charging tests were then carried out. The unit successfully charged a 2022 Tesla Model 3 (via CCS1 to NACS adapter) and a 2023 Chevrolet Silverado EV (see Figure 3.16).



**Figure 3.16: Photos showing testing FreeWire Boost Charger 200 during final commissioning process at Magaña Ortega Maintenance Yard**

These initial tests indicated that the unit could not deliver charge simultaneously from its two output connectors unless the unit's internal battery's

SOC is above 55% as indicated by the warning shown on the front display of the unit displayed in Figure 3.17.



**Figure 3.17: Front display of FreeWire Boost Charger 200 showing SOC indicator and warning indicating that the other CCS1 port was using all available power**

SpeedCharge later informed the team that dual vehicle charging is possible only when splitting the maximum charging rate between the two vehicles, meaning that the first connected vehicle accepts no more than 100 kW charging power.

## **FreeWire Boost Charger 200 Internet Connectivity**

Due to security concerns from Caltrans' Information Technology (IT) department, connecting the FreeWire Boost Charger 200 directly to Caltrans' private network was infeasible. An internet connection is necessary for data collection and monitoring the unit. The FreeWire Boost Charger 200 comes pre-installed with a Sierra Wireless MP70 wireless modem and SIM card; in this configuration, the unit can access the internet, allowing Caltrans and AHMCT engineers to access telemetry data.

The SIM card was pre-installed on the unit and activated during final commissioning on February 18, 2025. SpeedCharge and personnel at the

Magaña Ortega Maintenance Station verified that this connection operated correctly by ensuring data transfer from the modem.



**Figure 3.18: Sierra Wireless MP70 installed on Caltrans' FreeWire Boost Charger 200. After setup, the modem showed a solid green network and Wi-Fi LEDs. The activity LED was flashing amber, indicating that data was being transferred successfully via the ethernet port.**

**Table 3.5: Code description for indicator light-emitting diodes (LEDs) on Sierra Wireless MP70 [7]**

LED	Color/Pattern	Description
<b>Network</b>	Solid Green	Connected to an LTE network
	Solid Amber	Connected to a 3G or 2G network
	Flashing Green	Connecting to the network
	Flashing Red	No network available

LED	Color/Pattern	Description
	Flashing Red/Amber	Network Operator Switching is enabled, but the router is unable to locate the required firmware.
<b>Activity</b>	Flashing Green	Traffic is being transmitted or received over the WAN interface.
	Flashing Red	Traffic is being transmitted or received over the serial port. This behavior only appears if the MP70 is configured to display it.
	Flashing Amber	Traffic is being transmitted or received over both the WAN interface and the serial port.
<b>GNSS</b>	Green	The router has a GNSS fix.
	Flashing	No GNSS fix
	Off	GNSS is disabled.
<b>Wi-Fi</b>	Off	Wi-Fi is disabled.
	Solid Green	Wi-Fi is enabled.
	Solid Amber	Wi-Fi is enabled, and the router is connected to an Access Point (i.e., Wi-Fi is being used as the WAN connection)
	Flashing (Green or Amber)	Wi-Fi traffic is being sent or received.
<b>ALL</b>	Green LED chase	Radio module reconfiguration/firmware update or Network Operator Switching is in progress.
	Amber LED chase	ALEOS software update is in progress.

## Data Acquisition

Among the telemetry programs surveyed during this research, ChargePoint was the only software compatible with the charger. The AHMCT team aimed to collect the same parameters as the EVES-6060-NA. However, as outlined previously, this program did not provide the desired data or format to achieve

the intended research objectives. Instead, the research team requested the data that SpeedCharge collects for monitoring the system through their Asset Management Platform (AMP) software. AMP provides all necessary operational data for evaluation of the system. The data for analyzing all FreeWire Boost Charger 200 units mentioned above are also collected through AMP software.

# Chapter 4:

## EVESCO EVES-6060-NA System Evaluation

This section details Task 5 of the project: Evaluate Applicability and Feasibility of Systems. As outlined in the project proposal, the AHMCT team sought to evaluate the following items for the EVESCO EVES-6060-NA and FreeWire Boost Charger 200:

- System delivery with all required components.
- System's feasibility of supporting charging operations for Caltrans' light, medium, and heavy-duty EV fleet.
- System's charging output, duration, and total capacity.
- System's operating time on a single charge.
- Vendor support for installation, configuration, and ongoing operation.

The above items were addressed primarily through collection and analysis of the data for both units. Importantly, the AHMCT team also documented several qualitative parameters related to the units.

This section describes the evaluation of the EVESCO EVES-6060-NA unit. The testing period spanned nine (9) months between September 19, 2024, and June 30, 2025.

A test plan was developed to address the items listed above. Below is a list of specific conditions and objectives from this test plan:

- Test EVES-6060-NA discharging at normal temp. conditions (45° F – 75°F).
- Test EVES-6060-NA discharging at cold temp. conditions (30° F – 45° F).
- Test EVES-6060-NA discharging at hot temp. conditions (80° F – 100° F)
- Test EVES-6060-NA charging at normal temp. conditions (45° F – 75°F).
- Test EVES-6060-NA charging at cold temp. conditions (30° F – 45° F).
- Test EVES-6060-NA charging at hot temp. conditions (80° F – 100° F)
- Test compatibility between EVES-6060-NA and DCFC stations.
- Test compatibility between EVES-6060-NA and Caltrans fleet EVs.

The parameters observed for all testing are listed in Table 4.1.

**Table 4.1: Parameters recorded during compatibility testing**

Parameter	Units
<b>SOC (for EVES-6060-NA and recipient EV)</b>	Percent
<b>Current delivered or received.</b>	Amperes
<b>Voltage</b>	Volts
<b>Power delivered or received</b>	Kilowatts
<b>Energy delivered or received</b>	Kilowatt-Hours
<b>EVES-6060-NA battery cell temperatures (maximum/minimum)</b>	Degrees Fahrenheit

In addition to the defined parameters, the compatibility between the EVES-6060-NA and other EVs and charging stations was also assessed.

## Compatibility with Vehicles

A list of nine (9) EVs from Caltrans' fleet was initially provided to the AHMCT team with the objective of determining their compatibility with the EVES-6060-NA charger. Later the AHMCT team was informed by the panel that two of these vehicles (the Nissan Leaf and Toyota RAV4) will be retired soon, and therefore, no compatibility test was necessary for them. Table 4.2 summarizes the results of testing. EVs were considered compatible with the EVES-6060-NA if they successfully received a charge from the unit.

**Table 4.2: Compatibility between Caltrans' fleet EVs and the EVES-6060-NA**

EV Make	EV Model	EV Year	Compatibility	Notes
<b>Chevrolet</b>	Bolt	2022, 2023	Compatible	
<b>Chevrolet</b>	Silverado EV	2023	Compatible	
<b>Ford</b>	F150 Lightning	2023	Compatible	

EV Make	EV Model	EV Year	Compatibility	Notes
<b>Global</b>	M4 HSD	2019	Compatible	Functioned with EVES-6060-NA after being flashed for level 3 charging
<b>Tesla</b>	Model 3	2022	Compatible	Some trouble with the NACS connector and adapter
<b>Volkswagen</b>	ID.4	2022	Compatible	
<b>Volvo</b>	NRE62T	2023	Compatible	

As indicated in Table 4.2, all seven (7) tested vehicles were compatible with the EVES-6060-NA charger. Initially, the AHMCT team faced problems with charging the Global M4 HSD due to its inability to accept level 3 charging at the time. After the unit received a software update to accept level 3 charging, the EVES-6060-NA was able to charge the vehicle.

The AHMCT team encountered recurring issues when charging some Tesla models with the EVES-6060-NA. Multiple attempts were often needed to successfully initiate charging, both when using the unit's onboard NACS charging cable and when using a CCS1-to-NACS adapter. Similar problems were occasionally experienced with the Volkswagen ID.4. During failed attempts, the EVES-6060-NA either failed to recognize that the vehicle was connected or displayed an error message (0x10) when charging was initiated. EVESCO indicated that the problem was not related to the EVES-6060-NA.

The team tested three (3) additional vehicles that were not specified by Caltrans, which included a Chevrolet Equinox, Tesla Model S, and Tesla Model Y. These vehicles were found to be compatible with the unit. The following sections outline the charging statistics from tests conducted with each of the compatible vehicles.

# Chevrolet Bolt Compatibility Testing



**Figure 4.1: Chevrolet Bolt being charged by the EVES-6060-NA**

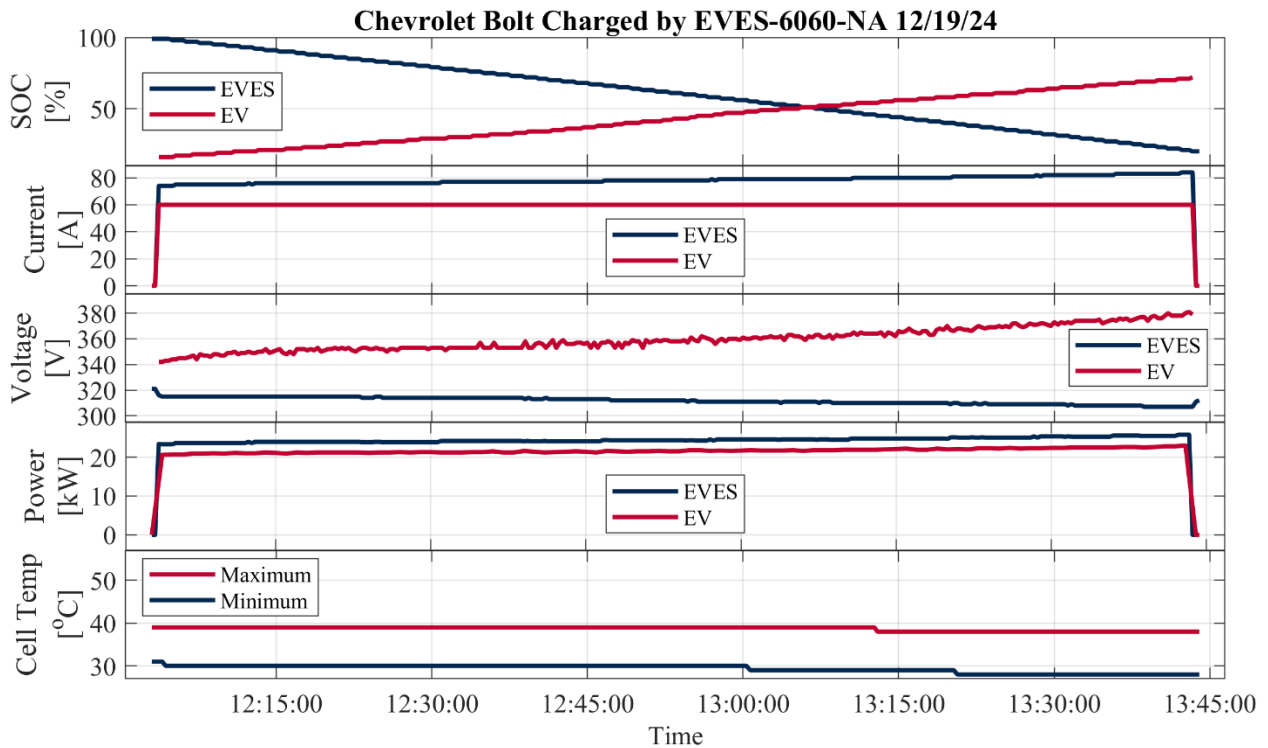
Charging the Chevrolet Bolt EV was tested in various weather conditions, including normal, hot, and cold temperatures. Figure 4.1 shows the Chevrolet Bolt being charged by the EVES-6060-NA unit during cold condition testing at the Kingvale maintenance station. Table 4.3 describes the charging sessions completed with the EVES-6060-NA.

**Table 4.3: Session data for EVES-6060-NA charging Chevrolet Bolt**

Date	11/ 13 24	12/ 18 24	12/ 18 24	12/ 19 24	02/ 26 25	02/ 26 25	06/ 04/ 25	06/ 16/ 25	06/ 17/ 25	06/ 18/ 25
<b>Total Charging Time [min]</b>	8	95	101	99	106	108	101	90	78	116
<b>EVES-6060-NA SOC Depletion</b>	100-95	95-19	98-20	99-20	96-8	99-13	100-23	99-29	100-38	99-11
<b>EV SOC Increase</b>	38-41	25-78	24-80	16-71	10-73	14-69	39-90	50-96	32-72	24-80
<b>Ambient Temperature Range [°F]</b>	57-58	34-43	34-36	44-44	39-45	32-34	91-93	89-95	93-94	98-100
<b>Cell Temperature Range [°F]</b>	57-59	48-73	68-84	42-102	64-81	75-99	86-104	73-93	93-104	93-109

Date	11/ 13 24	12/ 18 24	12/ 18 24	12/ 19 24	02/ 26 25	02/ 26 25	06/ 04/ 25	06/ 16/ 25	06/ 17/ 25	06/ 18/ 25
Energy Provided [kWh]	2.3 4	39. 86	41. 35	40. 75	42. 41	43. 93	39. 35	34. 67	30. 25	42. 96
Energy Received by the EV [kWh]	2.1 4	35. 03	36. 93	36. 09	38. 62	38. 68	35	30	27	38
Average Efficiency [%]	90. 11	87. 77	88. 53	88. 58	88. 76	88. 00	88. 20	86. 95	87. 71	87. 83
Maximum Power [kW]	16. 07	26. 10	26. 01	25. 79	25. 80	25. 62	26. 32	26. 10	25. 56	25. 93

Figure 4.2 shows the EVES-6060-NA and EV battery SOC, current, voltage, power, and minimum and maximum cell temperatures for the charging session on December 19, 2024. The other charging sessions plots are shown in Appendix A.



**Figure 4.2: EVES-6060-NA and EV SOC, current, voltage, power, and minimum and maximum battery cell temperatures for charging session of Chevrolet Bolt by the EVES-6060-NA unit**

# Chevrolet Equinox Compatibility Testing

The Chevrolet Equinox was tested on May 2, 2025, under normal weather conditions. This session was primarily completed to determine the compatibility between the Chevrolet Equinox and the EVES-6060-NA and thus was charged for a short duration. Figure 4.3 shows the vehicle being charged at ATIRC using the EVES-6060-NA.



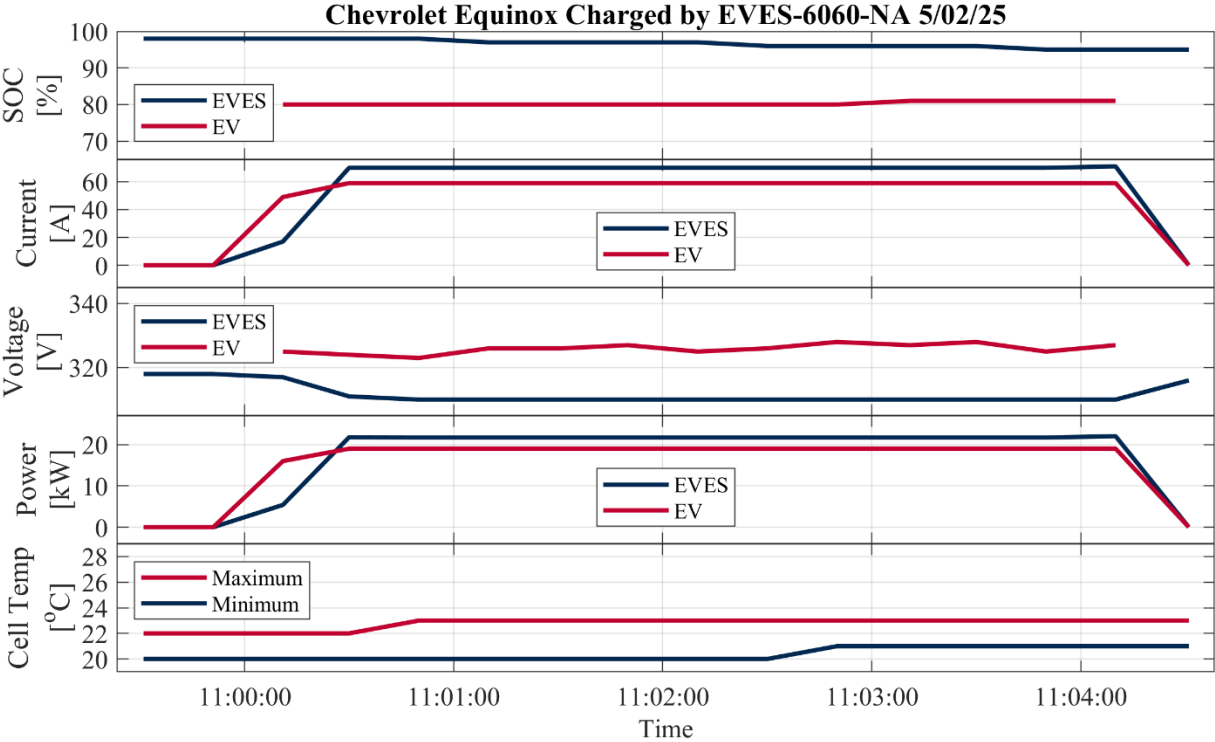
**Figure 4.3: Chevrolet Equinox being charged by the EVES-6060-NA**

Table 4.4 presents the data collected during a charging session with the Chevrolet Equinox.

**Table 4.4: Session data for EVES-6060-NA charging Chevrolet Equinox**

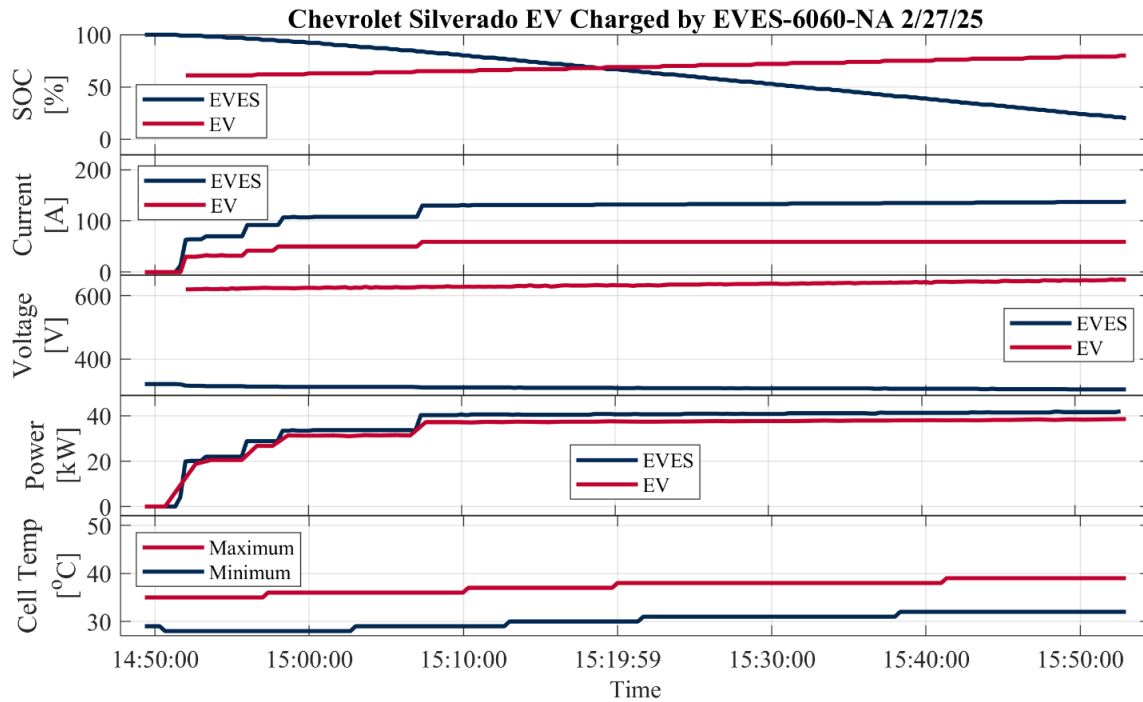
Date	05/02/2025
Total Charging Time [min]	4
EVES-6060-NA SOC Depletion	98-95
EV SOC Increase	80-81
Ambient Temperature Range [°F]	63-63
Cell Temperature Range [°F]	68-73
Energy Provided [kWh]	1.48
Energy Received by the EV [kWh]	1

<b>Date</b>	<b>05/02/2025</b>
<b>Average Efficiency [%]</b>	87.43
<b>Maximum Power [kW]</b>	22.01



**Figure 4.4: EVES-6060-NA and EV SOC, current, voltage, power, and minimum and maximum battery cell temperatures for charging session of Chevrolet Equinox by the EVES-6060-NA unit**

Figure 4.4 shows the EVES-6060-NA and EV battery SOC, current, voltage, power, and minimum and maximum cell temperatures for the charging session on May 2, 2025.



**Figure 4.5: EVES and EV SOC, current, voltage, power, and minimum and maximum battery cell temperatures for charging session of Chevrolet Silverado EV by the EVES-6060-NA unit**

## *Chevrolet Silverado EV Compatibility Testing*



**Figure 4.6: Chevrolet Silverado EV being charged by the EVES-6060-NA**

The results of the Chevrolet Silverado EV charging sessions are presented in Table 4.5, which includes data from multiple test conditions.

**Table 4.5: Session data for EVES-6060-NA charging Chevrolet Silverado EV**

Date	12/19/24	02/27/25
<b>Total Charging Time [min]</b>	65	60
<b>EVES-6060-NA SOC Depletion</b>	99-15	100-21
<b>EV SOC Increase</b>	37-59	61-80
<b>Ambient Temperature Range [°F]</b>	25-25	45-45
<b>Cell Temperature Range [°F]</b>	54-86	82-102
<b>Energy Provided [kWh]</b>	42.75	38.18
<b>Energy Received by the EV [kWh]</b>	39.28	35.76
<b>Average Efficiency [%]</b>	91.14	92.34
<b>Maximum Power [kW]</b>	40.53	41.79

Figures 4.5 and 4.7 show the EVES-6060-NA and EV battery SOC, current, voltage, power, and minimum and maximum cell temperatures for the charging sessions on February 27, 2025 and December 19, 2024. The other charging session plots are shown in Appendix A.

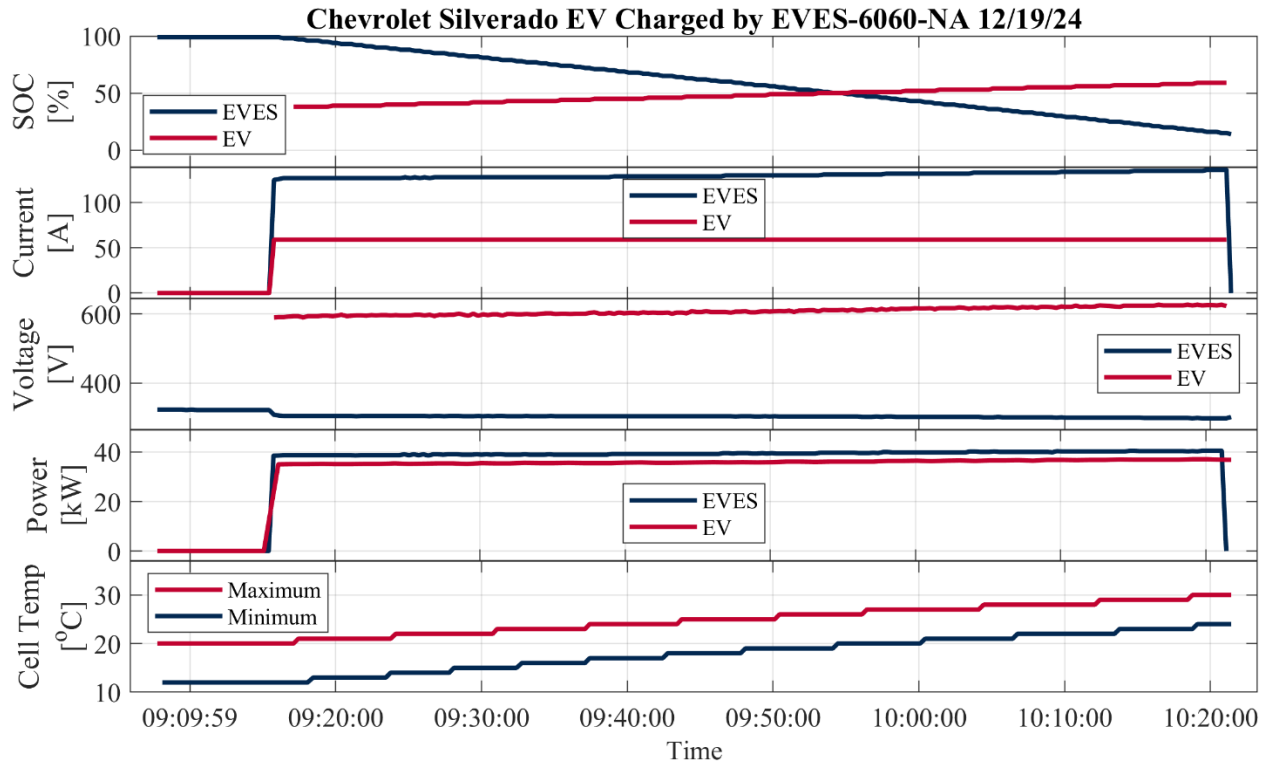


Figure 4.7: EVES and EV SOC, current, voltage, power, and minimum and maximum battery cell temperatures for charging session of Chevrolet Silverado EV by the EVES-6060-NA unit

## Ford F-150 Lightning Compatibility Testing



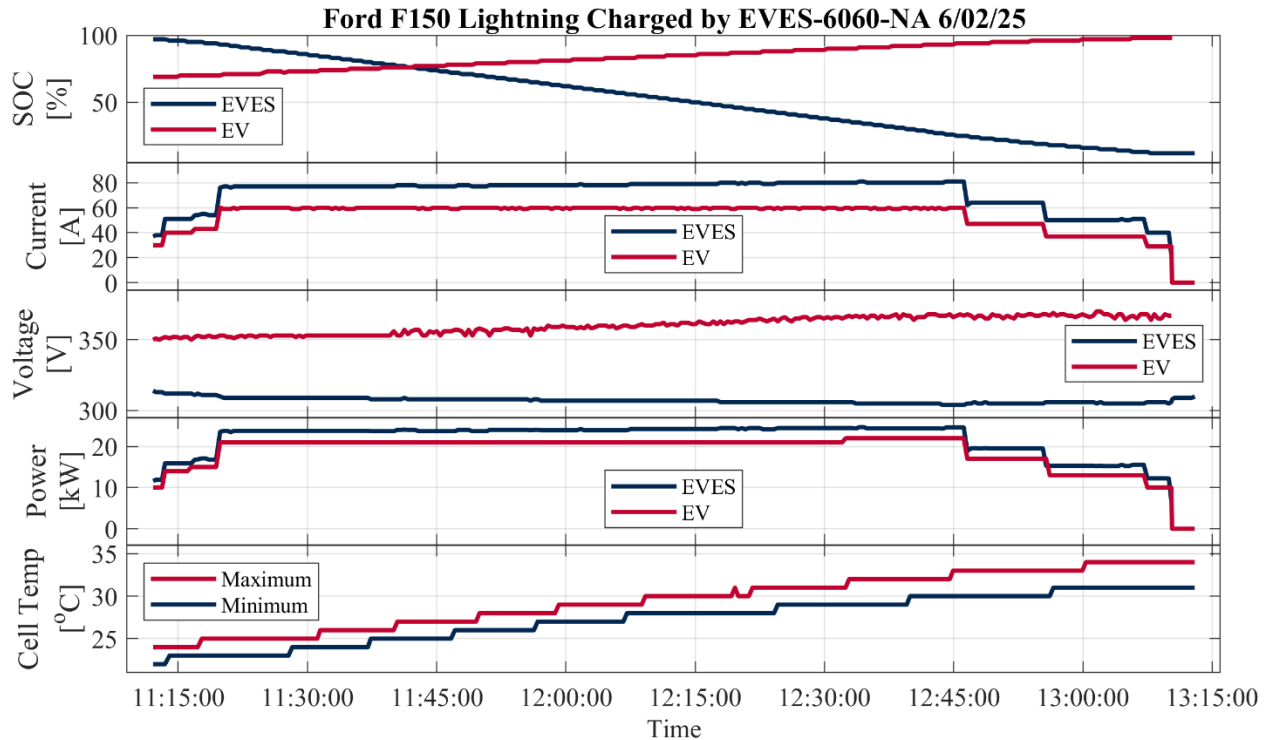
Figure 4.8: Ford F150 Lightning being charged by the EVES-6060-NA

On October 31, 2024, a Ford F150 Lightning was charged by the EVES-6060-NA unit with an ambient temperature of 60°F. As shown in Figure 4.8, the Ford F150 Lightning was successfully charged by the EVES-6060-NA unit during compatibility testing. A second Ford F150 Lightning was charged on June 2, 2025, to obtain a complete set of data. These data are listed seen in Table 4.6.

**Table 4.6: Session data for EVES-6060-NA charging Ford F150 Lightning**

Date	06/02/2025
<b>Total Charging Time [min]</b>	118
<b>EVES-6060-NA SOC Depletion</b>	97-12
<b>EV SOC Increase</b>	69-98
<b>Ambient Temperature Range [°F]</b>	77-80
<b>Cell Temperature Range [°F]</b>	72-93
<b>Energy Provided [kWh]</b>	43.40
<b>Energy Received by the EV [kWh]</b>	38
<b>Average Efficiency [%]</b>	87.63
<b>Maximum Power [kW]</b>	24.71

Figure 4.9 shows the EVES-6060-NA and EV battery SOC, current, voltage, power, and minimum and maximum cell temperatures for the charging session on June 2, 2025.



**Figure 4.9: EVES-6060-NA and EV SOC, current, voltage, power, and minimum and maximum battery cell temperatures for charging session of Ford 150 Lightning by the EVES-6060-NA unit**

## Global M4 HSD Compatibility Testing

The Global M4 HSD was charged successfully on May 5, 2025, at ATIRC using the EVES-6060-NA. The charge was completed under normal conditions. Figure 4.10 depicts the charging session.



**Figure 4.10: Global M4 HSD being charged by the EVES-6060-NA**

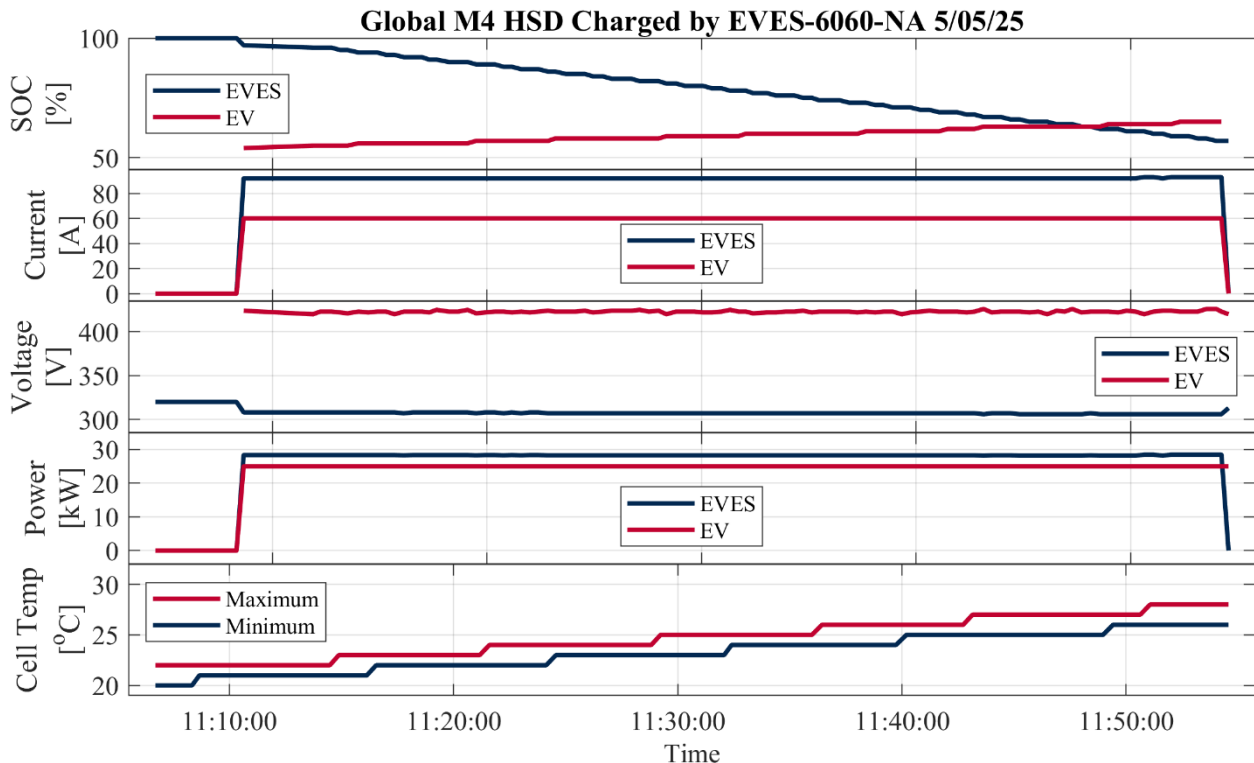
Table 4.7 presents the data collected during the charging session.

**Table 4.7: Session data for EVES-6060-NA charging Global M4 HSD**

Date	05/05/2025
Total Charging Time [min]	45
EVES-6060-NA SOC Depletion	100-57
EV SOC Increase	54-65
Ambient Temperature Range [°F]	77-80
Cell Temperature Range [°F]	68-82

Date	05/05/2025
Energy Provided [kWh]	21.63
Energy Received by the EV [kWh]	19
Average Efficiency [%]	88.41
Maximum Power [kW]	28.46

Figure 4.11 shows the EVES-6060-NA and EV battery SOC, current, voltage, power, and minimum and maximum cell temperatures for the charging session on May 5, 2025.



**Figure 4.11: EVES-6060-NA and EV SOC, current, voltage, power, and minimum and maximum battery cell temperatures for charging session of Global M4 HSD by the EVES-6060-NA unit**

# Tesla Model 3 Compatibility Testing

On February 27, 2024, a Tesla Model 3 was charged by the EVES-6060-NA unit. Figure 4.12 illustrates the Tesla Model 3 being charged by the EVES-6060-NA during compatibility testing.



**Figure 4.12: Tesla Model 3 being charged by the EVES-6060-NA**

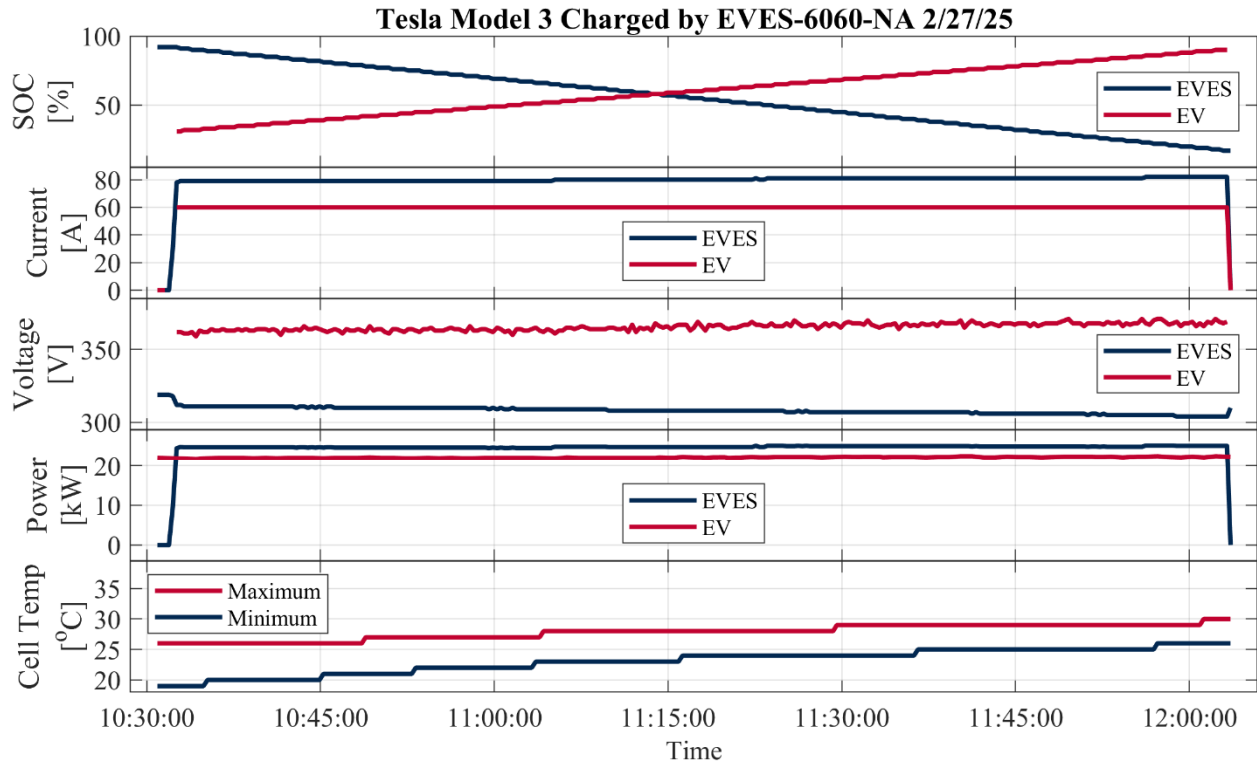
Table 4.8 presents the data collected during the charging session.

**Table 4.8: Session data for EVES-6060-NA charging Tesla Model 3**

Date	02/27/2025
Total Charging Time [min]	90
EVES-6060-NA SOC Depletion	92-17

Date	02/27/2025
EV SOC Increase	31-90
Ambient Temperature Range [°F]	45-50
Cell Temperature Range [°F]	66-86
Energy Provided [kWh]	37.49
Energy Received by the EV [kWh]	33.47
Average Efficiency [%]	89.08
Maximum Power [kW]	25.01

Figure 4.13 shows the EVES-6060-NA and EV battery SOC, current, voltage, power, and minimum and maximum cell temperatures for the charging session on February 27, 2025.



**Figure 4.13: EVES and EV SOC, current, voltage, power, and minimum and maximum battery cell temperatures for charging session of Tesla Model 3 by the EVES-6060-NA unit**

# Tesla Model S Compatibility Testing



**Figure 4.14: Tesla Model S being charged by the EVES-6060-NA**

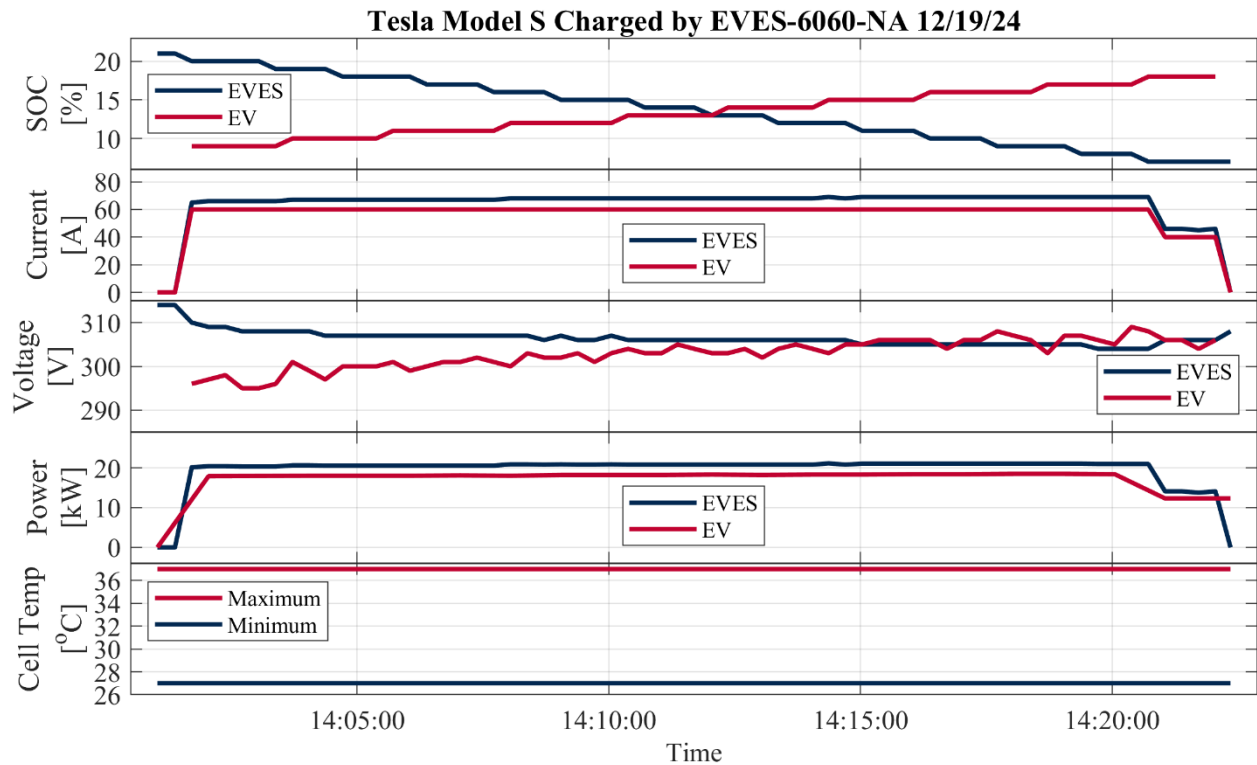
On December 19, 2024, the Tesla Model S was charged by the EVES-6060-NA unit with an ambient temperature of 45°F. The Tesla Model S required several attempts to charge successfully. Failed attempts were a result of a lack of data transmission between the EVES-6060-NA and the vehicle as indicated by a “0x10” error code shown on the unit. The team attempted to charge several times with both the NACS adapter on the EVES-6060-NA as well as a CCS1 to NACS adapter. Charging was eventually initiated via the NACS adapter. Table 4.9 presents the data collected during the charging session.

**Table 4.9: Session data for EVES-6060-NA charging Tesla Model S**

Date	12/19/2024
Total Charging Time [min]	20

Date	12/19/2024
<b>EVES-6060-NA SOC Depletion</b>	21-7
<b>EV SOC Increase</b>	9-18
<b>Ambient Temperature Range [°F]</b>	45-45
<b>Cell Temperature Range [°F]</b>	81-99
<b>Energy Provided [kWh]</b>	7.00
<b>Energy Received by the EV [kWh]</b>	6.17
<b>Average Efficiency [%]</b>	86.67
<b>Maximum Power [kW]</b>	21.11

Figure 4.15 shows the EVES-6060-NA and EV battery SOC, current, voltage, power, and minimum and maximum cell temperatures for the charging session on December 19, 2024.



**Figure 4.15: EVES and EV SOC, current, voltage, power, and minimum and maximum battery cell temperatures for charging session of Tesla Model S by the EVES-6060-NA unit**

## Tesla Model Y Compatibility Testing



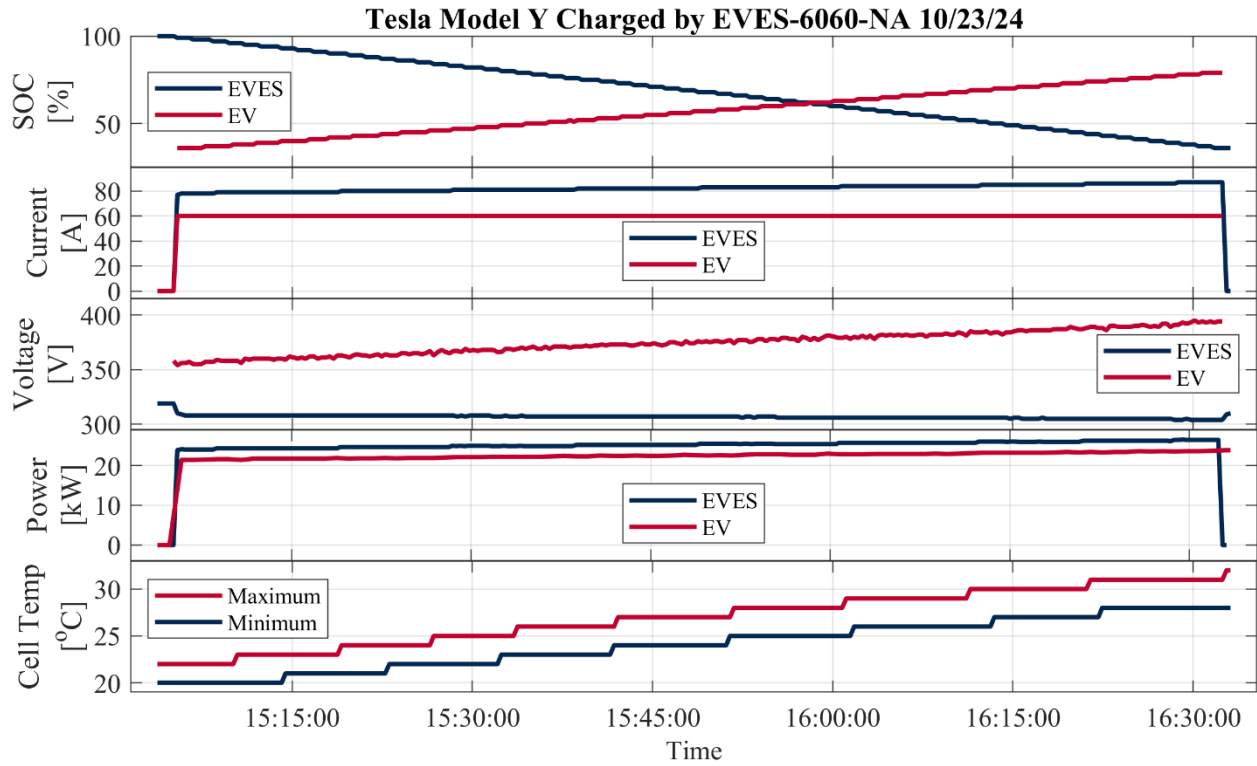
**Figure 4.16: Tesla Model Y being charged by the EVES-6060-NA**

Figure 4.16 shows the Tesla Model Y being charged by the EVES-6060-NA during compatibility testing. Table 4.10 describes the charging sessions completed for the Tesla Model Y with the EVES-6060-NA.

**Table 4.10: Session data for EVES-6060-NA charging Tesla Model Y**

Date	10/18/24	10/23/24	10/25/24	10/30/24
<b>Total Charging Time [min]</b>	52	86	122	108
<b>EVES-6060-NA SOC Depletion</b>	98-61	100-36	100-12	100-21
<b>EV SOC Increase</b>	49-90	36-79	18-78	37-89
<b>Ambient Temperature Range [°F]</b>	76-78	79-82	61-67	52-62
<b>Cell Temperature Range [°F]</b>	66-81	68-88	70-91	82-102
<b>Energy Provided [kWh]</b>	21.71	36.19	49.68	43.82
<b>Energy Received by EV [kWh]</b>	19.47	32.5	44.42	39.28
<b>Average Efficiency [%]</b>	89.32	89.18	88.62	89.18
<b>Maximum Power [kW]</b>	26.40	26.45	26.10	25.93

Figure 4.17 shows the EVES-6060-NA and EV battery SOC, current, voltage, power, and minimum and maximum cell temperatures for the charging session on October 23, 2024. The other charging sessions plots are shown in Appendix A.



**Figure 4.17: EVES and EV SOC, current, voltage, power, and minimum and maximum battery cell temperatures for charging session of Tesla Model Y by the EVES-6060-NA unit**

## Volkswagen ID.4 Compatibility Testing



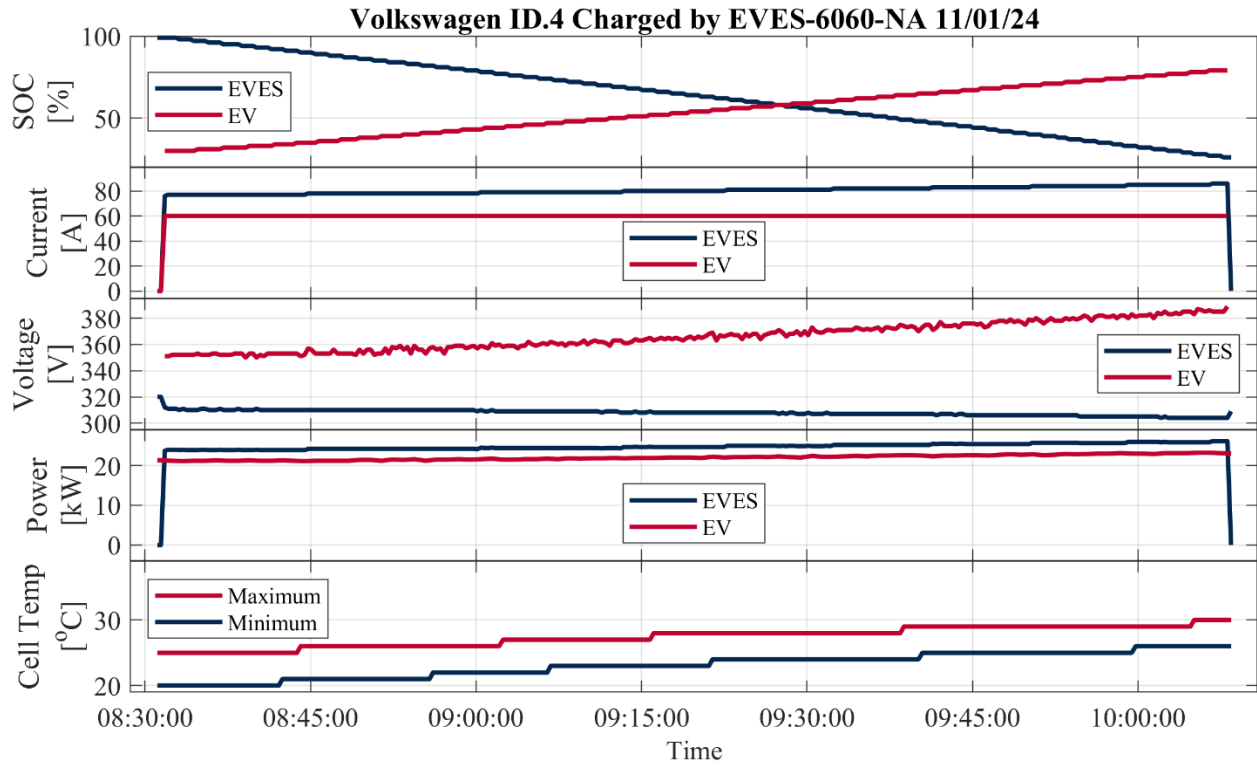
**Figure 4.18: Volkswagen ID.4 being charged by the EVES-6060-NA**

As illustrated in Figure 4.18, the Volkswagen ID.4 was connected to the EVES-6060-NA for compatibility testing. Table 4.11 describes the charging sessions completed for the Volkswagen ID.4 with the EVES-6060-NA.

**Table 4.11: Session data for EVES-6060-NA charging Volkswagen ID.4**

Date	09/19/24	10/29/24	11/01/24	11/14/24	06/05/25	06/11/25
<b>Total Charging Time [min]</b>	89	88	95	93	98	103
<b>EVES-6060-NA SOC Depletion</b>	96-33	100-35	99-27	95-24	100-23	100-19
<b>EV SOC Increase</b>	32-79	35-79	30-79	34-79	30-79	28-79
<b>Ambient Temperature Range [°F]</b>	69-71	51-52	44-55	61-63	83-86	74-80
<b>Cell Temperature Range [°F]</b>	75-90	68-86	68-86	14-27	33-39	24-33
<b>Energy Provided [kWh]</b>	37.58	36.42	39.16	38.08	38.91	40.38
<b>Energy Received by EV [kWh]</b>	34.16	32.60	35.19	33.49	34	35
<b>Average Efficiency [%]</b>	89.04	88.87	89.10	88.94	87.93	87.20
<b>Maximum Power [kW]</b>	25.93	26.01	26.14	25.97	25.79	25.93

Figure 4.19 shows the EVES-6060-NA and EV battery SOC, current, voltage, power, and minimum and maximum cell temperatures for the charging session on November 1, 2024. The other charging sessions plots are shown in Appendix A.



**Figure 4.19: EVES and EV SOC, current, voltage, power, and minimum and maximum battery cell temperatures for charging session of Volkswagen ID.4 by the EVES-6060-NA unit**

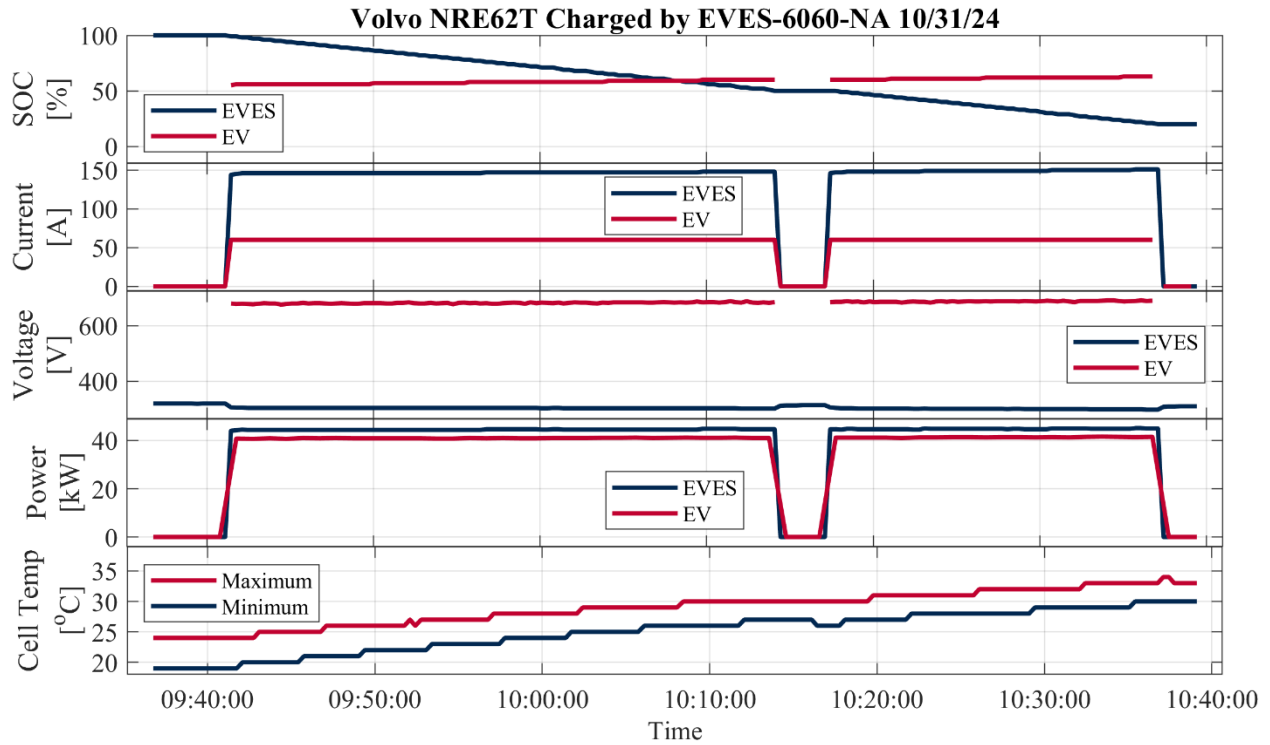
# Volvo NRE62T Compatibility Testing

On October 31, 2024, a Volvo NRE62T was charged by the EVES-6060-NA unit at the Caltrans Sacramento Head Quarters. Table 4.12 presents the data collected during the charging session.

**Table 4.12: Session data for EVES-6060-NA charging Volvo NRE62T**

Date	10/31/2024
Total Charging Time [min]	55
EVES-6060-NA SOC Depletion	100-20
EV SOC Increase	55-63
Ambient Temperature Range [°F]	55-57
Cell Temperature Range [°F]	19-34
Energy Provided [kWh]	39.44
Energy Received by the EV [kWh]	36.15
Average Efficiency [%]	91.33
Maximum Power [kW]	45.15

Figure 4.20 shows the EVES-6060-NA and EV battery SOC, current, voltage, power, and minimum and maximum cell temperatures for the charging session on October 31, 2024.



**Figure 4.20: EVES and EV SOC, current, voltage, power, and minimum and maximum battery cell temperatures for charging session of Volvo NRE62T by the EVES-6060-NA**

## Compatibility with 480V AC Charger

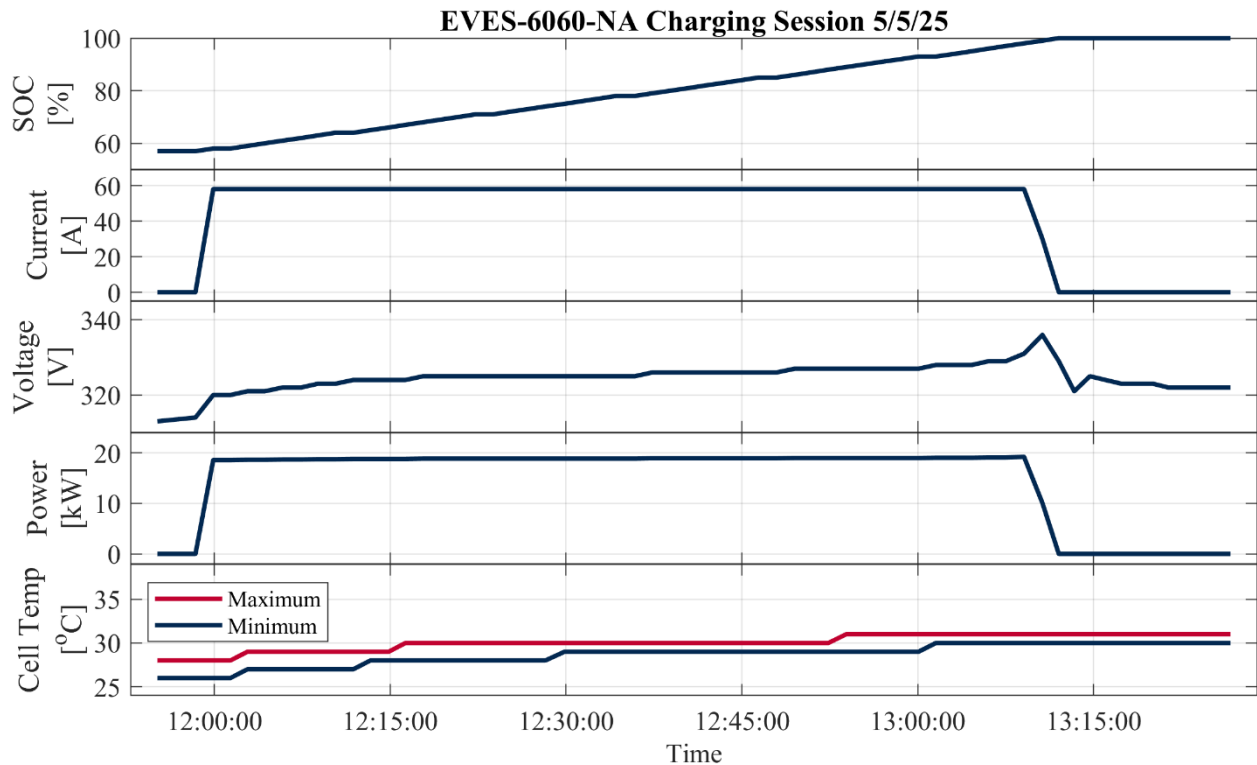
The EVES-6060-NA unit was able to be successfully charged at the ATIRC facility with 480V AC power. The charging statistics for such charging sessions are provided in Table 4.13.

**Table 4.13: Statistics for Charging Sessions for 6 sample charging sessions of the EVES-6060-NA unit at the ATIRC facility with 480V AC power**

Date	10/18/24	10/29/24	02/11/25	05/05/25	06/05/25	06/10/25
Total Charging Time [min]	73	121	121	70	128	127
SOC Range [%]	61-98	36-98	35-98	57-100	24-100	24-100

Date	10/18/24	10/29/24	02/11/25	05/05/25	06/05/25	06/10/25
<b>Ambient Temperature Range [°F]</b>	78-79	67-71	48-54	81-83	73-80	83-88
<b>Cell Temperature Range [°F]</b>	79-88	72-91	81-127	79-88	79-100	75-99
<b>Energy Transferred [kWh]</b>	22.99	28.15	37.97	22.48	40.24	40.05
<b>Max Power [kW]</b>	19.7	19.43	19.43	19.20	19.43	19.43

Figure 4.21 shows the EVES-6060-NA battery SOC, current, voltage, power, and minimum and maximum cell temperatures for the May 5 charging session. The data for the other sessions are depicted in Appendix A.



**Figure 4.21: SOC, current, voltage, power, and minimum and maximum battery cell temperatures for a charging session of EVES-6060-NA by 3-phase 480V AC power at ATIRC facility**

## Compatibility with DCFCs

Efforts were made to charge the EVES-6060-NA at several DCFC stations throughout the duration of the project. Findings from this test were used to evaluate the viability of using DCFC stations to charge the unit if it is incorporated into Caltrans' operations.

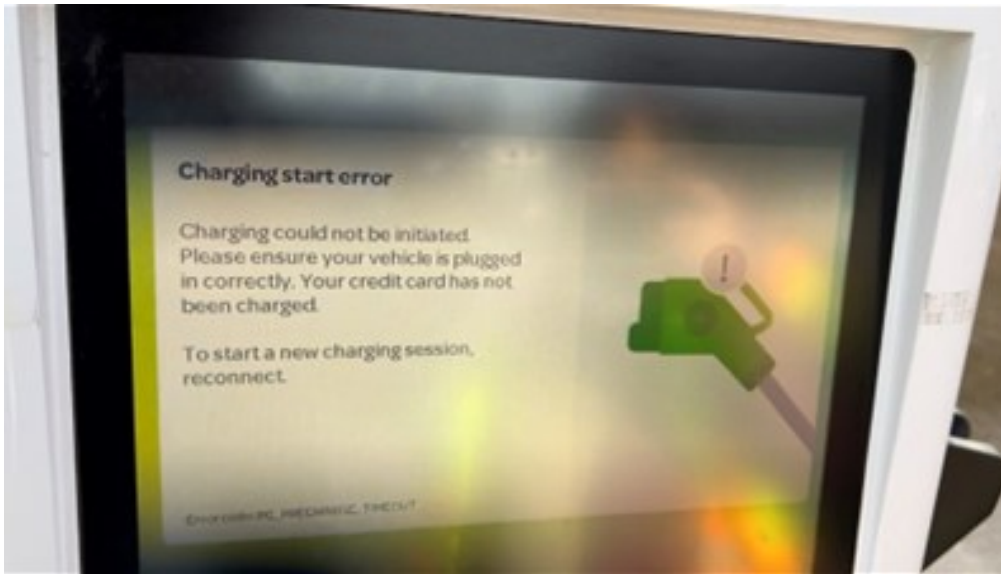
The results of such tests suggest that the compatibility between the EVES-6060-NA and other DCFC stations is unpredictable. In total, the EVES-6060-NA was tested at ten separate charging stations and with 23 individual chargers. Of these 23 chargers, eight (8) were operational (able to initiate and complete a full charge) with the EVES-6060-NA, suggesting an overall success rate of  $\approx 35\%$ . The results of this compatibility test are tabulated in Table 4.14.

**Table 4.14: Compatibility between EVES-6060-NA and other DCFCs**

Charger	Address	Max power (kW)	Adapter Used	Chargers tested	Functional with EVES-6060-NA
ChargePoint	90 Cisco Rd, Emigrant Gap, CA 95715	62.5	CCS1	2	1
ChargePoint	10069 Donner Pass Rd, Truckee, CA 96161	62.5	CCS1	2	1
ChargePoint	4010 Lake Rd, West Sacramento, CA 95691	125	CCS1	1	1
EVgo	2115 6th St, Sacramento, CA 95818	175	CCS1	1	1
EVgo	500 1st St, Davis, CA 95616, USA	50	CCS1	N/A	N/A

Charger	Address	Max power (kW)	Adapter Used	Chargers tested	Functional with EVES-6060-NA	
<b>EVgo</b>	100 W River Rd, Tahoe City, CA 96145	50	CCS1	3	0	
<b>Electrify America</b> (Did not function following update.)	325 E Street, Davis, California, 95616, US	150	CCS1	4	2	
<b>Electrify America</b>	1651 Alhambra Blvd, Sacramento, CA 95816	150	CCS1	3	0	
<b>Electrify America</b>	Broadway &, 2505 Riverside Blvd EB, Sacramento, CA 95818	150	CCS1	3	0	
<b>Electrify America</b>	11399 Deerfield Dr, Truckee, CA 96161	350	CCS1	2	2	
<b>Tesla Supercharger</b>	140 W Lake Blvd, Tahoe City, CA 96145	150	CCS1 (using NACS to CCS1 adapter)	2	0	
				Total	23	8

When attempting to charge the EVES-6060-NA, DCFCs frequently accepted payment but did not deliver charge; in these instances, the DCFC displayed an error screen indicating that it was unable to charge the unit (example shown in Figure 4.22).



**Figure 4.22: Error screen shown by Electrify America DCFC in Truckee when attempting to charge the EVES-6060-NA**

Despite contacting customer support for DCFCs that did not function with the EVES-6060-NA, no solutions were identified for each occurrence. Furthermore, EVESCO representatives informed the AHMCT team that the problems were not attributed to the unit.

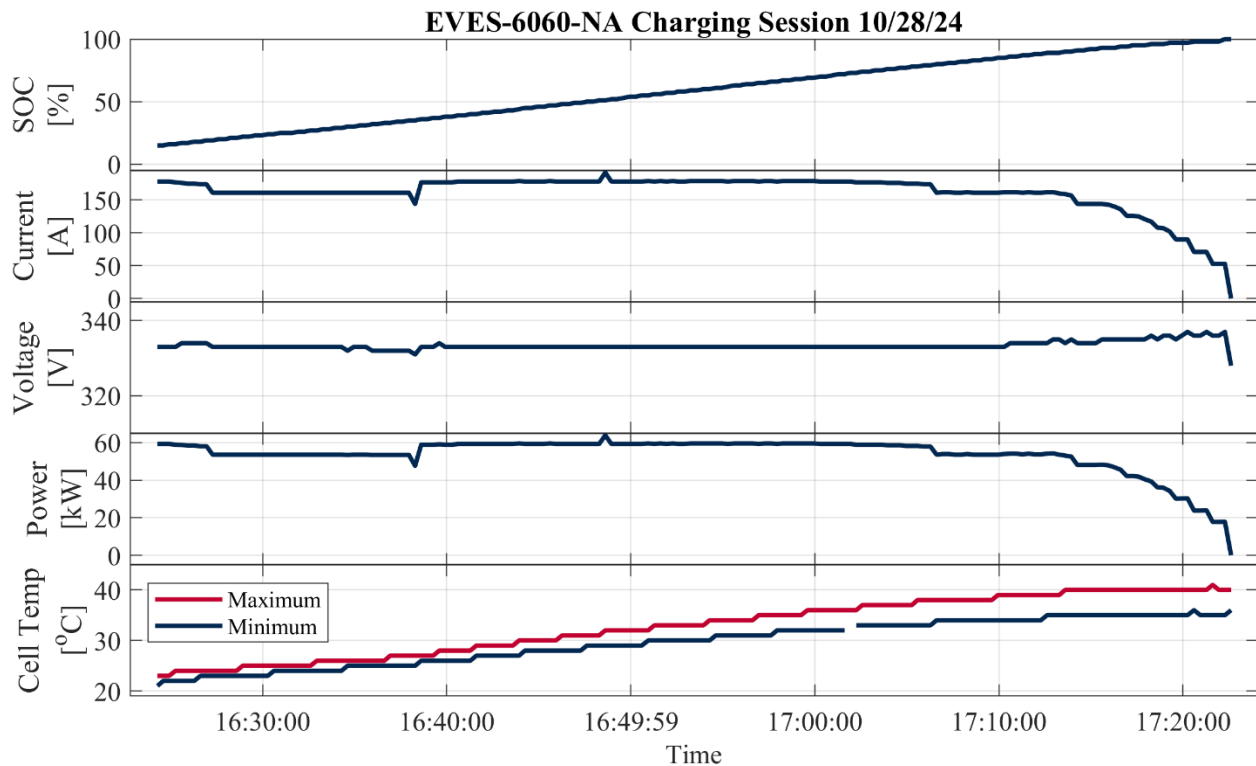
It was noted that the EVES-6060-NA does not accept charge from DCFC stations unless it is connected to the internet. When attempting to initiate charge without an internet connection, the EVES-6060-NA would display an error code indicating that no data had been transferred between the unit and the EV (0x10). However, the unit accepted AC charging without access to the internet.

**Table 4.15: Statistics for Charging Sessions of the EVES-6060-NA unit at the Electrify America DCFC located at the Davis Bank of America**

Date	10/7/24	10/28/24	10/30/24	10/31/24
<b>Total Charging Time [min]</b>	44	58	36	44
<b>SOC Range [%]</b>	34-98	15-100	21-89	18-100
<b>Ambient Temperature Range [°F]</b>	75-84	65-66	64-64	61-65

Date	10/7/24	10/28/24	10/30/24	10/31/24
Cell Temperature Range [°F]	79-108	70-104	77-111	79-117
Energy Transferred [kWh]	41.77	52.69	41.85	48.92
Max Power [kW]	65.40	59.61	69.93	73.81

Table 4.15 presents the detailed statistics for the charging sessions conducted with the EVES-6060-NA unit at the Electrify America DCFC located at the Davis Bank of America. These data points illustrate the charging performance across multiple testing dates. Figure 4.23 shows the EVES-6060-NA battery SOC, current, voltage, power, and minimum and maximum cell temperatures for the October 28 charging session. The data for the other sessions are depicted in Appendix A.



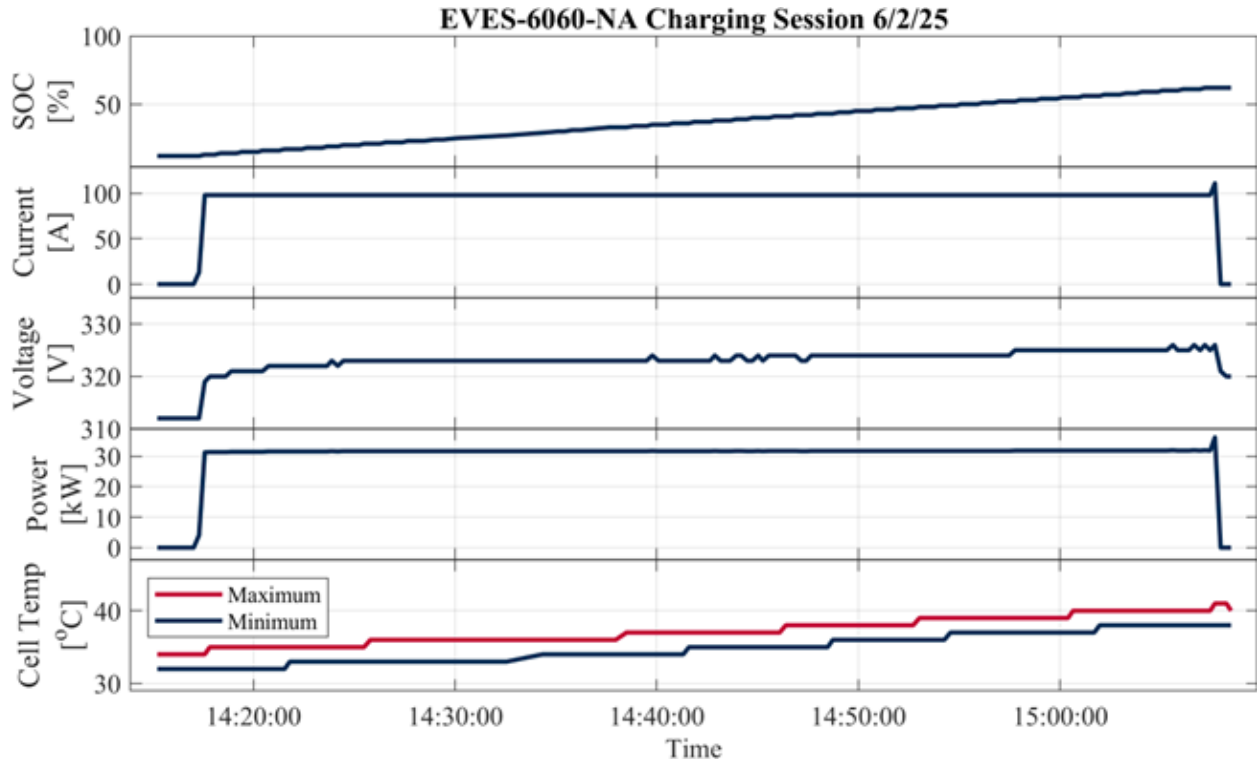
**Figure 4.23: SOC, current, voltage, power, and minimum and maximum battery cell temperatures for charging session of EVES-6060-NA at the Electrify America DCFC located at the Davis Bank of America**

Table 4.16 presents the detailed statistics for the charging sessions conducted with the EVES-6060-NA unit at the Davis EVgo DCFC. These data points illustrate the charging performance across multiple testing dates.

**Table 4.16: Statistics for Charging Sessions of the EVES-6060-NA unit at the EVgo DCFC located in Davis**

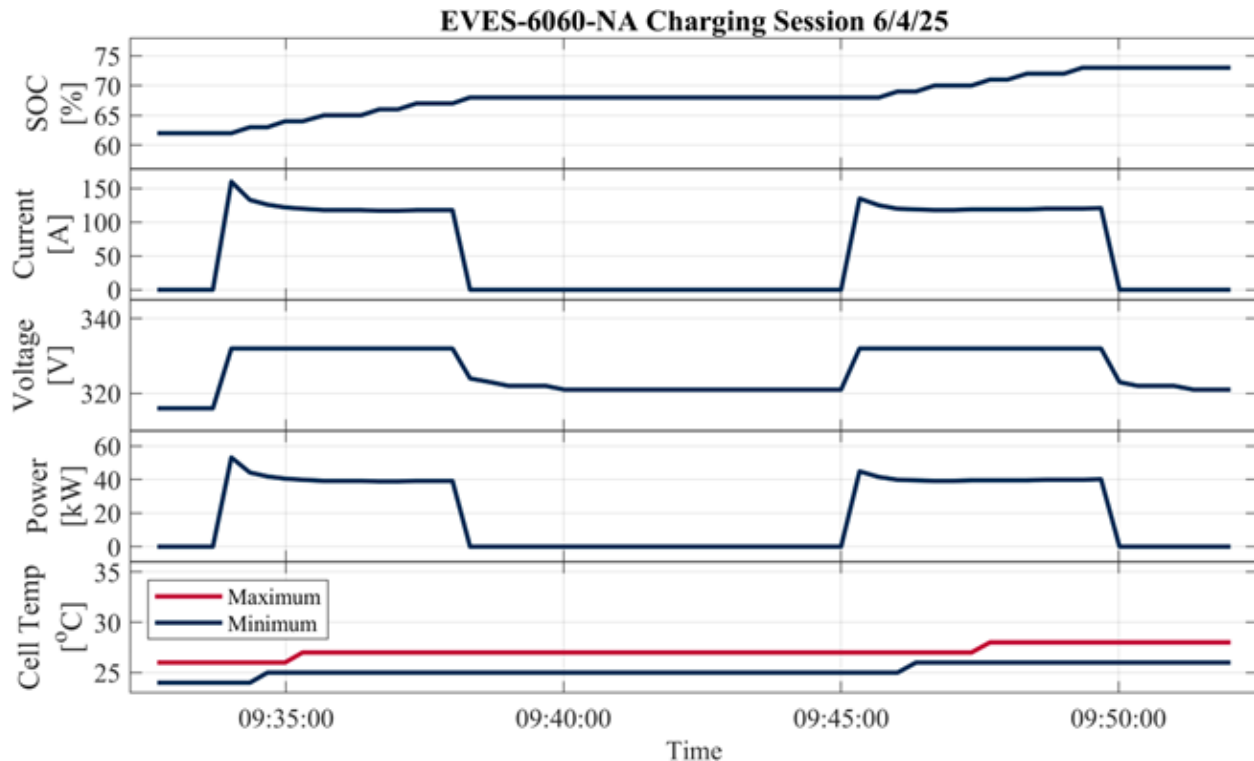
<b>Date</b>	<b>06/02/25</b>	<b>06/12/25</b>	<b>06/17/25</b>	<b>06/18/25</b>	<b>06/20/25</b>
<b>Total Charging Time [min]</b>	50	78	68	59	84
<b>SOC Range [%]</b>	12-62	19-100	30-100	39-100	12-100
<b>Ambient Temperature Range [°F]</b>	86-90	87-89	82-87	86-87	82-86
<b>Cell Temperature Range [°F]</b>	90-106	77-100	75-97	81-99	77-100
<b>Energy Transferred [kWh]</b>	26.66	42.08	36.81	31.97	45.34
<b>Max Power [kW]</b>	36.19	35.97	36.73	38.23	36.61

Figure 4.24 shows the EVES-6060-NA battery SOC, current, voltage, power, and minimum and maximum cell temperatures for the June 2 charging session. The data for the other sessions are depicted in Appendix A.



**Figure 4.24: SOC, current, voltage, power, and minimum and maximum battery cell temperatures for a charging session of EVES-6060-NA by the Davis EVgo DCFC**

Additionally, the EVES-6060-NA unit was charged with the Sacramento ChargePoint DCFC in hot weather on June 4. The charging session was idle for approximately 7 minutes in the middle of the charging session for unknown reasons. During the charging session, the EVES-6060-NA SOC increases from 62% to 73%, while 6.07 kWh of total energy is delivered in 15 minutes with a maximum power of 53.12 kW. The charging session occurs with an ambient temperature of 70°F to 75°F and a cell temperature from 75°F to 82°F. Figure 4.25 shows the EVES-6060-NA battery SOC, current, voltage, power, and minimum and maximum cell temperatures for the charging session.



**Figure 4.25: SOC, current, voltage, power, and minimum and maximum battery cell temperatures for a charging session of EVES-6060-NA by the Sacramento ChargePoint DCFC**

Finding compatible DCFCs that can charge the EVES-6060-NA was a primary challenge for operations outside the UC Davis campus, especially in unfamiliar areas during the cold weather tests. During the first cold temperature test, AHMCT team had one primary choice and one secondary choice for DCFC stations to be used to charge the EVES-6060-NA as seen in Table 4.8: an Electrify America charging station and a ChargePoint charging station, respectively.

At the Electrify America charging station, three chargers were available. Each accepted payment and attempted to initiate charging with the EVES-6060-NA model, but none successfully started the charging process. Despite multiple restarts of the EVES-6060-NA device and contacting Electrify America customer support, the issue persisted. Customer support attempted a remote restart of the charging unit, but this did not resolve the problem, and they offered no additional troubleshooting assistance.

The AHMCT team then tried to charge at a ChargePoint charging station but encountered similar problems; this charger also accepted payment but did not deliver charge. As such, the team then went to an EVgo charging station, which was closed at the time despite reportedly being operational according to several charger location applications and websites.

Subsequently, the team attempted to charge at a Tesla Supercharger using an NACS to CCS1 adapter. However, this was impossible since a Tesla vehicle identification number (VIN) must be provided in the Tesla app to initiate charging. The team was finally able to initiate charging at another ChargePoint charging station in Emigrant Gap. The locations of all of the charging stations tested are shown in the map in Figure 4.26.



**Figure 4.26: Locations of the charging stations tested for cold condition testing**

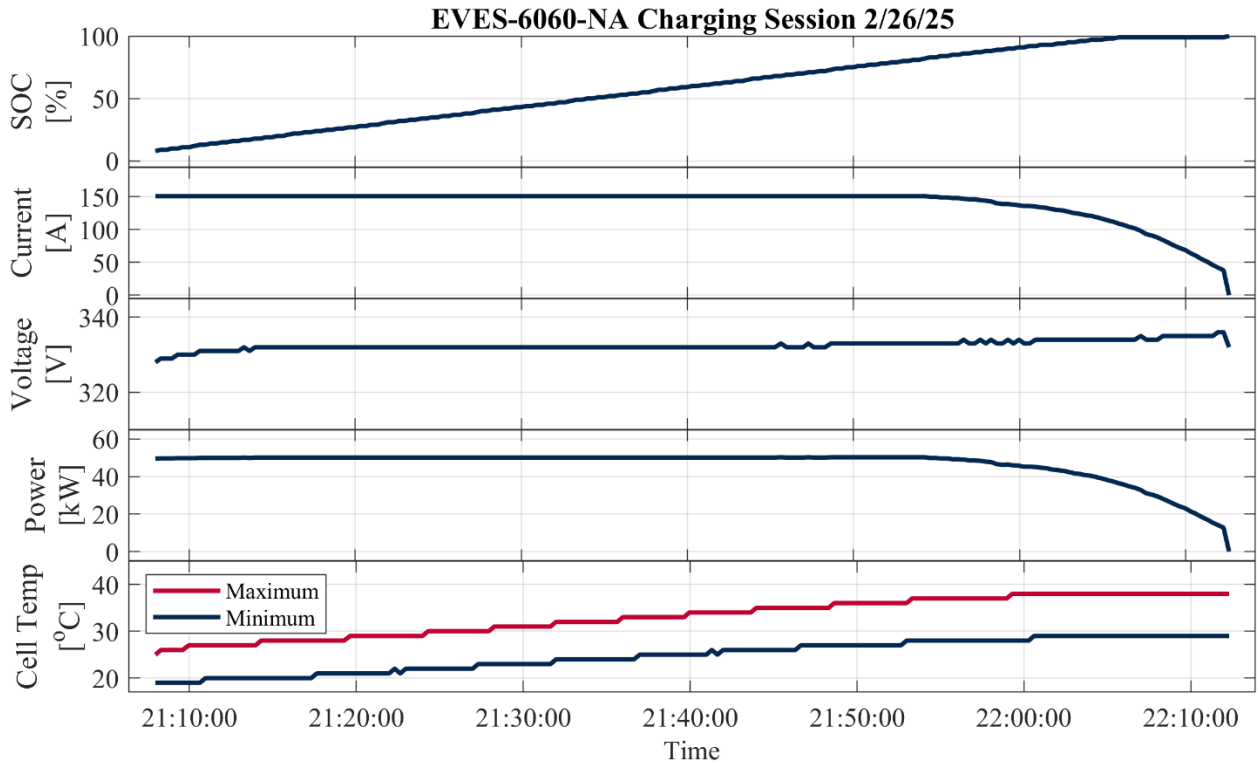
Table 4.17 describes charging statistics for the charging sessions at this public DCFC.

**Table 4.17: Statistics for Charging Sessions of the EVES-6060-NA unit at the ChargePoint DCFC located in Emigrant Gap**

Date	12/18/ 24	12/19/ 24	12/19/ 24	12/19/ 24	02/26/ 24	02/27/ 25	02/27/ 25
<b>Total Charging Time [min]</b>	74	146	58	61	64	106	106

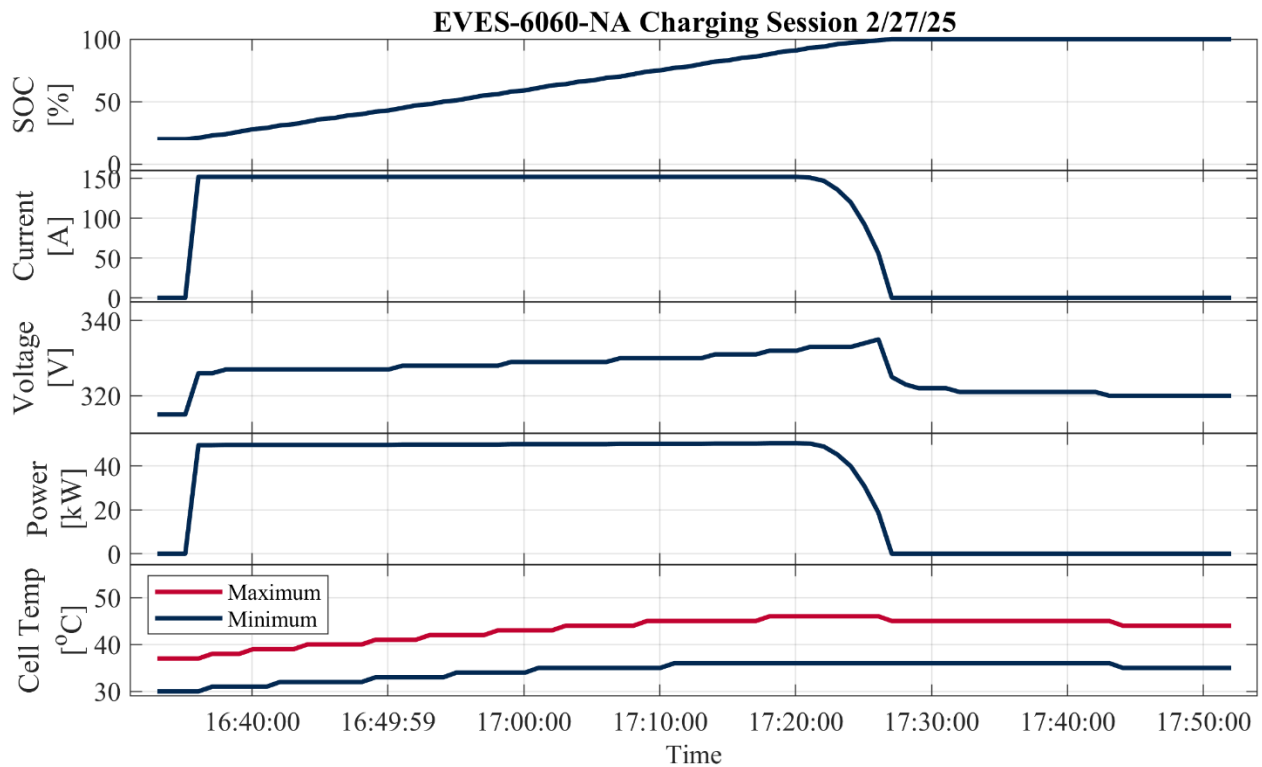
Date	12/18/ 24	12/19/ 24	12/19/ 24	12/19/ 24	02/26/ 24	02/27/ 25	02/27/ 25
<b>SOC Range [%]</b>	29-99	21-97	14-100	7-100	8-99	14-92	18-100
<b>Ambient Temp [°F]</b>	36-45	28-28	44-46	38-42	38-39	29-32	45-45
<b>Cell Temp [°F]</b>	55-88	37-72	73-104	75-113	66-100	44-81	79-97
<b>Energy [kWh]</b>	41.71	44.11	47.05	50.31	50.38	42.48	42.23
<b>Max Power [kW]</b>	39.75	23.18	50.28	50.28	50.28	24.72	24.64

Figure 4.27 shows the EVES-6060-NA battery SOC, current, voltage, power, and minimum and maximum cell temperatures for the February 26 charging session. The data for the other sessions are depicted in Appendix A.



**Figure 4.27: SOC, current, voltage, power, and minimum and maximum battery cell temperatures for charging session of EVES-6060-NA at the ChargePoint DCFC located in Emigrant Gap**

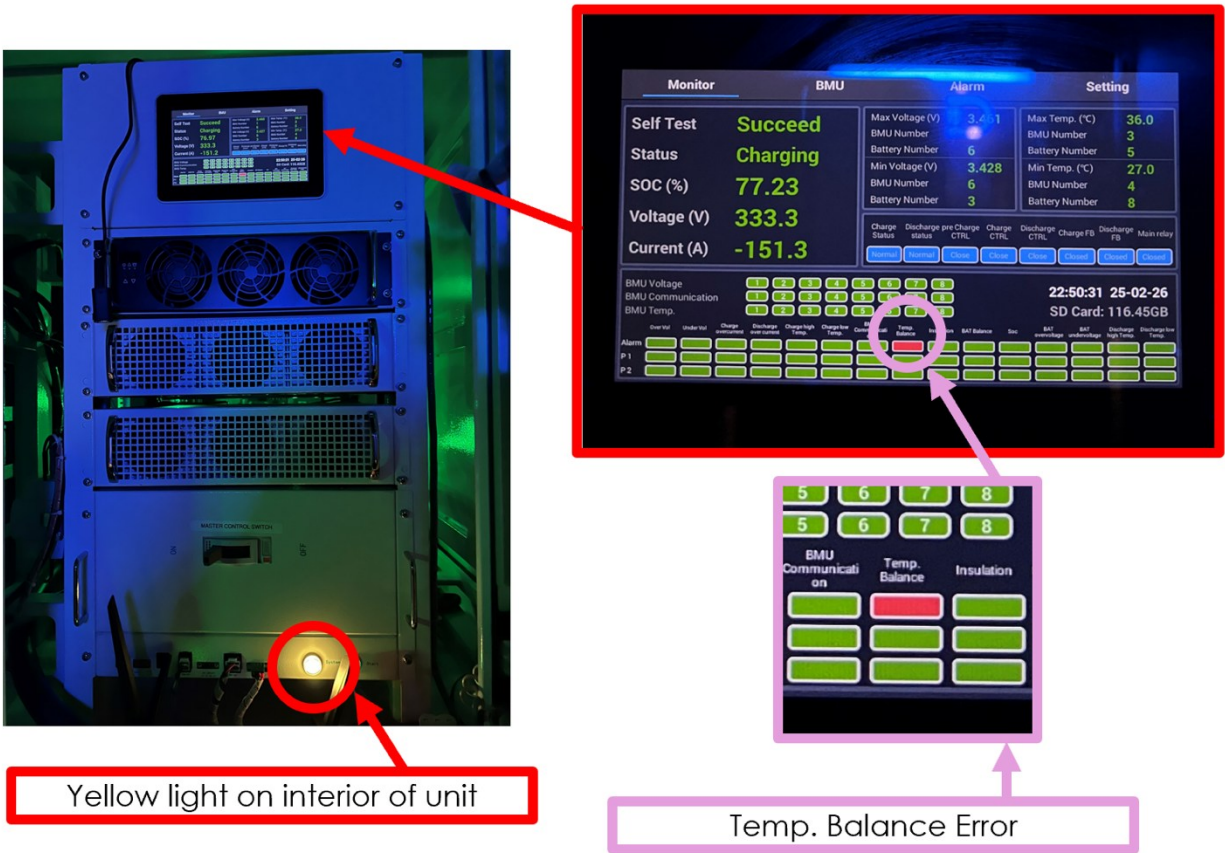
On February 27, 2025, the EVES-6060-NA unit was charged at the ChargePoint DCFC located in downtown Truckee at an ambient temperature of 40°F. The EVES-6060-NA was charged from a SOC of 20% to 100%. This charge took 50 minutes and provided 41.38 kWh of energy with a maximum power of 50.46 kW. Figure 4.28 shows the EVES-6060-NA battery SOC, current, voltage, power, and minimum and maximum cell temperatures for this charging session.



**Figure 4.28: SOC, current, voltage, power, and minimum and maximum battery cell temperatures for charging session of EVES-6060-NA at the ChargePoint DCFC located in downtown Truckee**

### *Temperature Balance Error*

While performing tests with the EVES-6060-NA in cold conditions, the AHMCT team noted a recurring error when the unit was exposed to temperatures between 29°F to 39°F. As can be seen in Figure 4.29, the indicator light on the inside of the unit turned yellow. (A green light indicates a normal status.) The interior display also showed a single cell icon as red, indicating that there was a temperature balance error.



**Figure 4.29: Temperature balance error seen on the EVES-6060-NA in cold conditions**

The temperature balance error made initiating charging sessions unpredictable. While the error was present, several attempts were required to initiate charge between the unit and public DCFCs. In each instance that charge failed to initiate, a "0x10" error code would appear on the screen, indicating that no data had been transmitted between the EVES-6060-NA and the EV or public DCFC.

The performance of the EV was not affected by this error, which was confirmed by comparing the parameters logged with the temperature balance error present against the parameters logged with no errors present.

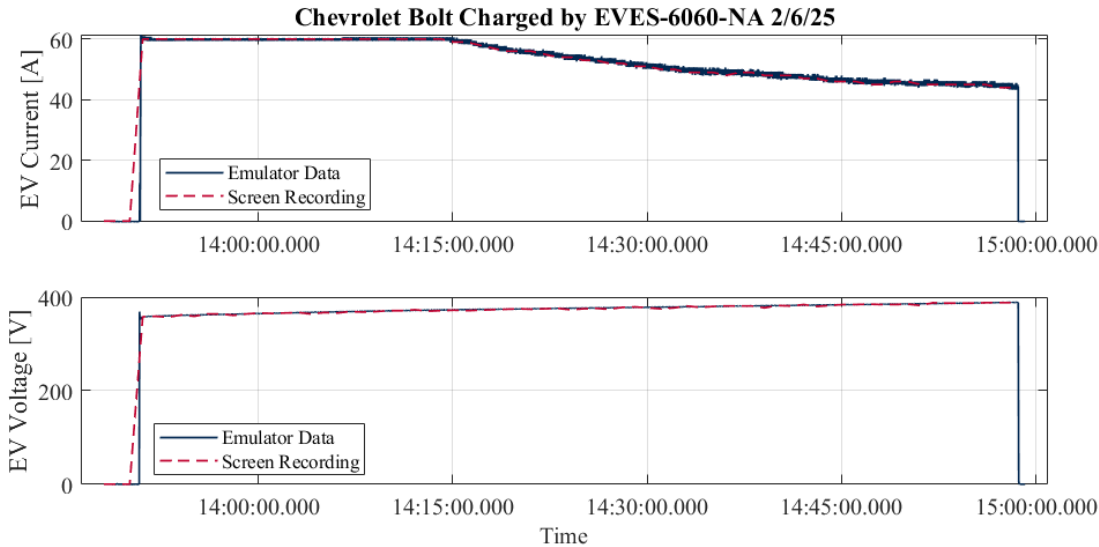
Since this error occurred only in low temperatures, a method of mitigating this issue is to preheat the unit's cells before use in cold conditions or to avoid storing the unit in temperatures below 39°F.

The AHMCT team noted that this error did not occur when conducting charging sessions in hot weather conditions. Even in temperatures exceeding 100°F, the system operated normally.

# Battery Emulator Testing

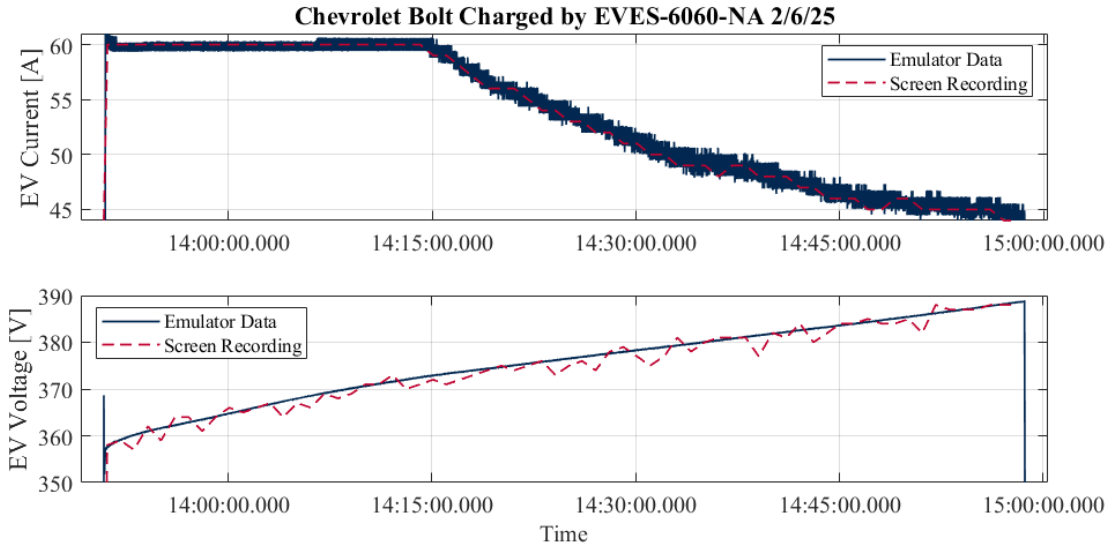
## Man in the Middle Testing

To independently verify the data reported on the EVES-6060-NA screen and to measure the real time, accurate, high resolution charging current and voltage provided by the EVES-6060-NA during EV charging, a Keysight SL1040A battery emulator was used in “man in the middle” mode. In this configuration, the emulator is connected in between the EVES-6060-NA and the EV so it can measure the parameters of the charging power. Figure 4.30 shows the current and voltage provided to the Chevrolet Bolt from the EVES-6060-NA measured from both the screen recording and emulator.



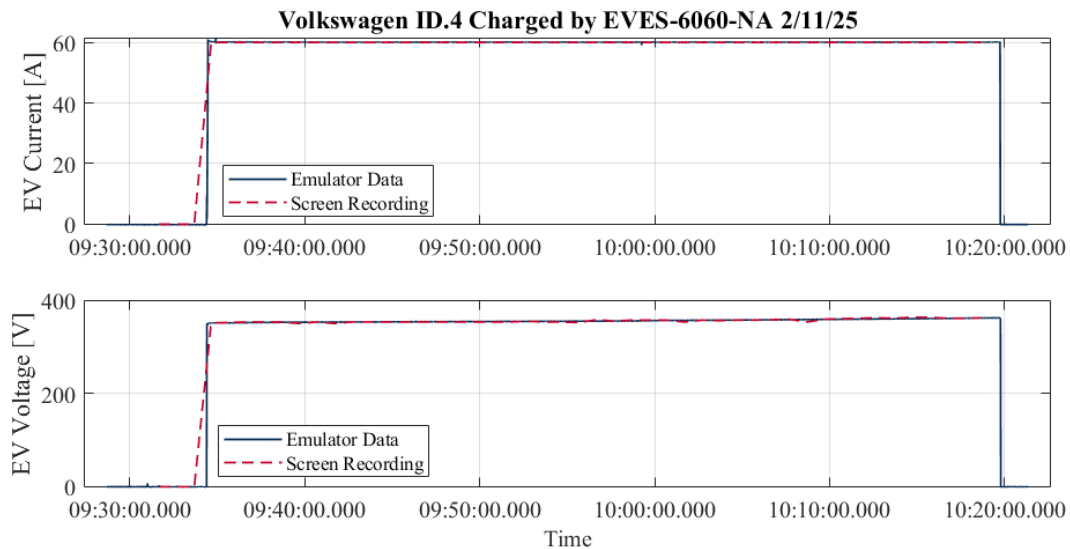
**Figure 4.30: Current and voltage for a charging session of the Chevrolet Bolt by the EVES-6060-NA measured by the emulator and through screen recording**

A closer look at the charging current and voltage is shown in Figure 4.31 where the higher resolution of the emulator data can be seen. Additionally, the data displayed on the screen for the current and voltage are rounded to the nearest Ampere (A) or Volt (V) whereas the emulator provides a more accurate measurement of these values during the charging session.



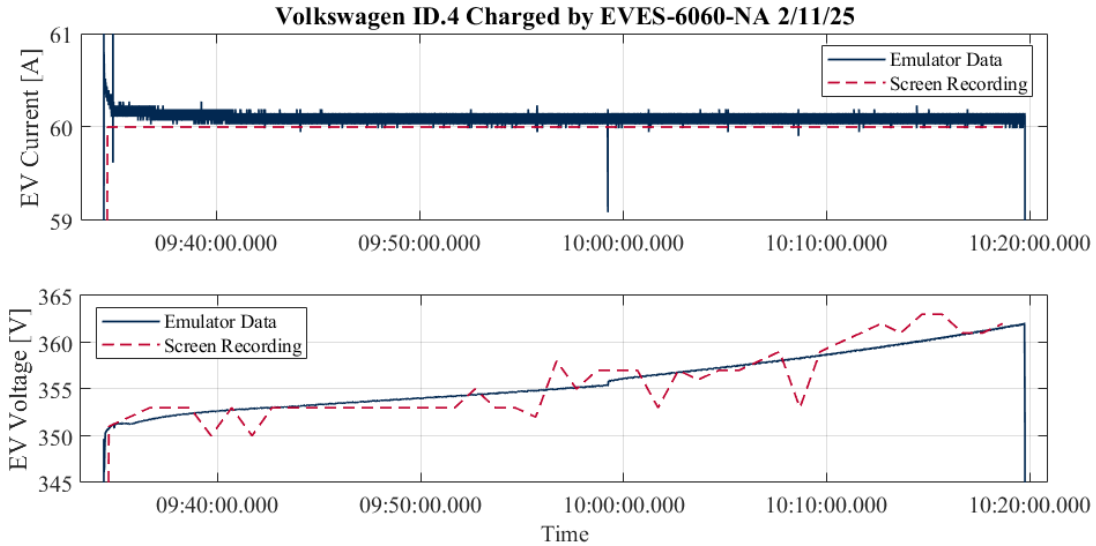
**Figure 4.31: Close up of the current and voltage for a charging session of the Chevrolet Bolt by the EVES-6060-NA measured by the emulator and through screen recording**

Figure 4.32 shows the current and voltage provided to the Volkswagen ID.4 from the EVES-6060-NA measured from both the screen recording and emulator.



**Figure 4.32: Current and voltage for a charging session of the Volkswagen ID.4 by the EVES-6060-NA measured by the emulator and through screen recording**

A closer look at the charging current and voltage is shown in Figure 4.33 where the higher resolution of the emulator data can be seen.



**Figure 4.33: Close up of the current and voltage for a charging session of the Volkswagen ID.4 by the EVES-6060-NA measured by the emulator and through screen recording**

Results from the tests performed using the battery emulator and a Vector sniffer tool (VH5110A) suggested an answer to the compatibility problems between the EVES-6060-NA and commercial chargers. The Vector sniffer tool suggested that the EVES-6060-NA utilizes the DIN spec 70121:2012 charging protocol. This charging protocol is outdated; the ISO 15118 protocol is now the standard used by new public chargers and EVs. As such, the AHMCT team infers that the EVES-6060-NA was unable to initiate charging sessions with more recent public DCFCs due to a lack of support for the DIN spec 70121:2013 charging protocol.

```

33.393711 SV: 2 0 1 ::Common::SysProtocolBar = 3
33.450510 ETH 1 Rx 86:001823A844608C34FD055DD986DD600000002006FFFE00000000000000C34FDFEF
33.450679 SV: 3 0 1 ::SCC::Monitor::Common::SchemaNamespace = "urn:din:70121:2012:MsgDef"
33.450679 SV: 2 0 1 ::SCC::Monitor::Common::SchemaVersionMajor = 2

```

**Figure 4.34: Vector log indicating that the EVES-6060-NA utilizes the DIN spec 70121:2012 charging protocol Close up of the Current and Voltage for a charging session of the Volkswagen ID.4 by the EVES-6060-NA measured by the emulator and through screen recording**

Despite the small differences between the emulator's reported values and the data displayed by the EVES-6060-NA, the measurements are generally consistent. This consistency validates all reported measurements for EVES-6060-NA experiments disclosed throughout this chapter. In addition, the Vector sniffer tool is capable of reading and displaying the communication signals between the charger and the EV. Reading these communication signals, it was discovered that EVES-6060-NA supports EV battery voltage up to 900 V. Given

that the charging current is limited to 60 A, this will result in 54kW of maximum power transfer rate for charging.

```
133.254443 SV: 3 0 1 ::SCC::Monitor::Response_Parameters::EVSEIsolationStatus = "Valid"
133.254443 SV: 3 0 1 ::SCC::Monitor::Response_Parameters::EVSEStatusCode = "EVSE_Ready"
133.254443 SV: 3 0 1 ::SCC::Monitor::Response_Parameters::EVSENotification = "None"
133.254443 SV: 2 0 1 ::SCC::Monitor::Response_Parameters::NotificationMaxDelay = 10
133.254443 SV: 1 0 1 ::SCC::Monitor::Response_Parameters::EVSEMaximumCurrent = 60
133.254443 SV: 1 0 1 ::SCC::Monitor::Response_Parameters::EVSEMaximumPower = 54000
133.254443 SV: 1 0 1 ::SCC::Monitor::Response_Parameters::EVSEMaximumVoltage = 900
133.254443 SV: 1 0 1 ::SCC::Monitor::Response_Parameters::EVSEPresentCurrent = 60.8
133.254443 SV: 1 0 1 ::SCC::Monitor::Response_Parameters::EVSEOutputPower = 21462.4
133.254443 SV: 2 0 1 ::SCC::Monitor::Response_Parameters::EVSEVoltageLimitAchieved = 0
133.254443 SV: 2 0 1 ::SCC::Monitor::Response_Parameters::EVSECurrentLimitAchieved = 0
```

**Figure 4.35: Vector log indicating that the maximum output power of the EVES-6060-NA is 54 KW**

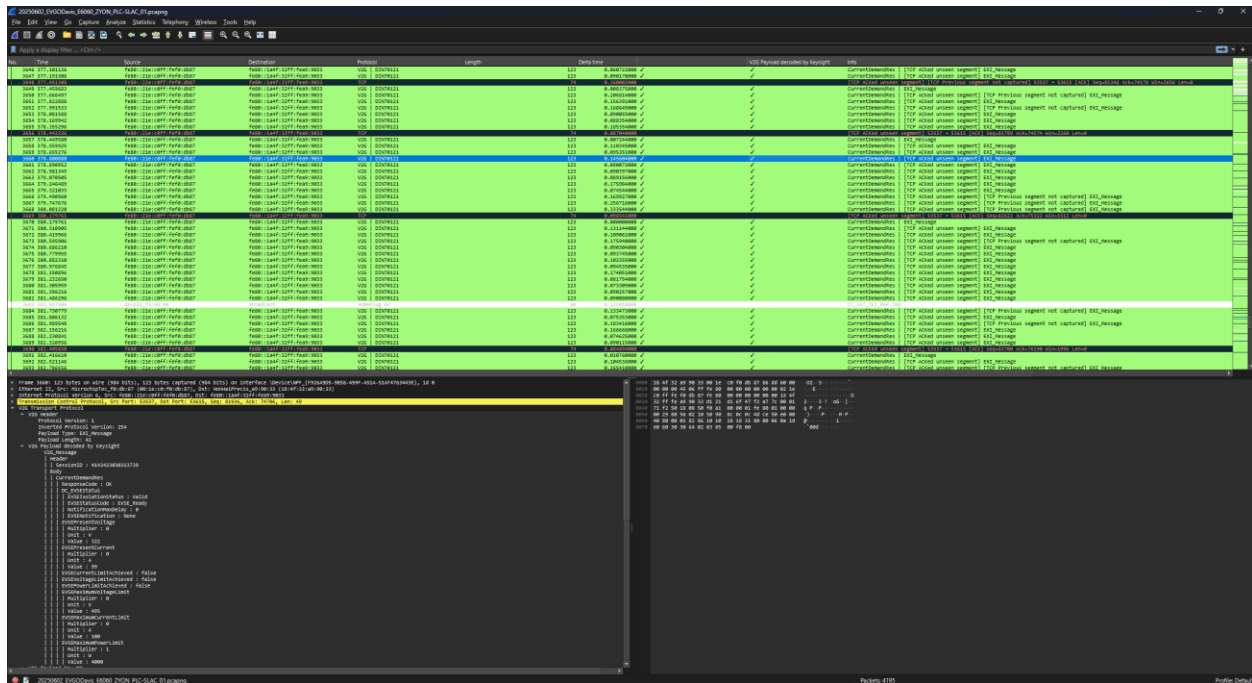
## DCFC Compatibility Diagnostics (Keysight PLC Tracer)

To identify root causes of incompatibility issues between EVES-6060-NA and public DCFCs, a power line communication (PLC) tracer analysis was conducted. A PLC tracer is a diagnostic tool that captures and analyzes ISO 15118 vehicle-to-grid (V2G) communication protocol messages exchanged between the EV (here, EVE-6060-NA acts as the EV when being charged) and the charging station during a charging session. By examining these communication logs, we could identify specific protocol failures, timing issues, and authentication problems that prevent successful charging sessions.

The following lists the data collection and analysis methodology:

- Hardware Setup: [SL1556A CCS Charging Protocol Tracer \(https://www.keysight.com/us/en/product/SL1556A/ccs-charging-protocol-tracer.html\)](https://www.keysight.com/us/en/product/SL1556A/ccs-charging-protocol-tracer.html) device was connected between the EVES-6060-NA and the charging station to capture all HomePlug Green PHY communication signals during charging sessions
- Data Capture: The tracer recorded raw PLC communication data including all V2G protocol messages, timestamps, and TCP/IP packet information
- Data Processing: Captured data were analyzed using the Wireshark network protocol analyzer with the Keysight V2G plugin extension, which enables:

- Decoding of ISO 15118 protocol messages (SessionSetupReq/Res, AuthenticationReq/Res, etc.)
- Identification of EXI (Efficient XML Interchange) encoded V2G messages
- Analysis of TCP packet health and retransmission rates
- Precise timing analysis of protocol handshaking sequences



**Figure 4.36: PLC trace showing decoded ServiceDiscoveryRes during ISO 15118 V2G communication between EVESCO EVES-6060-NA and EVgo DCFC**

- Analysis method: Each charging session log was examined for:
  - Protocol phase completion status
  - Message retry counts and timeout events
  - TCP packet loss rates and communication quality
  - Specific error codes and failure points
- The V2G communication protocol follows a structured sequence of phases, each serving a specific purpose:
  - Protocol negotiation: Initial handshake where EV and charger agree on communication protocol version
  - Session setup: Establishes a secure communication session between EV and charger

- Service discovery: EV learns what services the charger offers (DC charging, payment options, etc.)
- Payment selection: EV selects payment method (contract-based or external payment)
- Contract authentication: Verification of charging contract certificates and authorization
- Charge parameters discovery: EV and charger exchange battery parameters and charging limits
- Cable check: Tests cable insulation and ensures safe electrical connection
- Pre-charge: Aligns voltage between charger and EV battery before main power transfer
- Power delivery: Initiates main DC power transfer to the vehicle
- Current demand: Continuous power transfer with EV requesting current based on battery needs
- Welding detection: Checks if contactors are welded before disconnection
- Session stop: Safely terminates charging session and disconnects

**Table 4.18: PLC Tracer Analysis Summary for EVES-6060-NA Compatibility with Public DCFCs**

Charging Network	Charging Achieved	Failure Point	Root Cause	Recommended Action
<b>ChargePoint</b>	Yes	None - Successful	N/A	Monitor infrastructure
<b>EVgo</b>	Yes	Multiple phases	Infrastructure degradation	Infrastructure maintenance required
<b>Electrify America</b>	No	Authentication (19s timeout)	Certificate/protocol incompatibility	Software update for authentication

Charging Network	Charging Achieved	Failure Point	Root Cause	Recommended Action
<b>Tesla Supercharger</b>	No	Protocol negotiation	Proprietary protocol	Not compatible with CCS1/ISO 15118

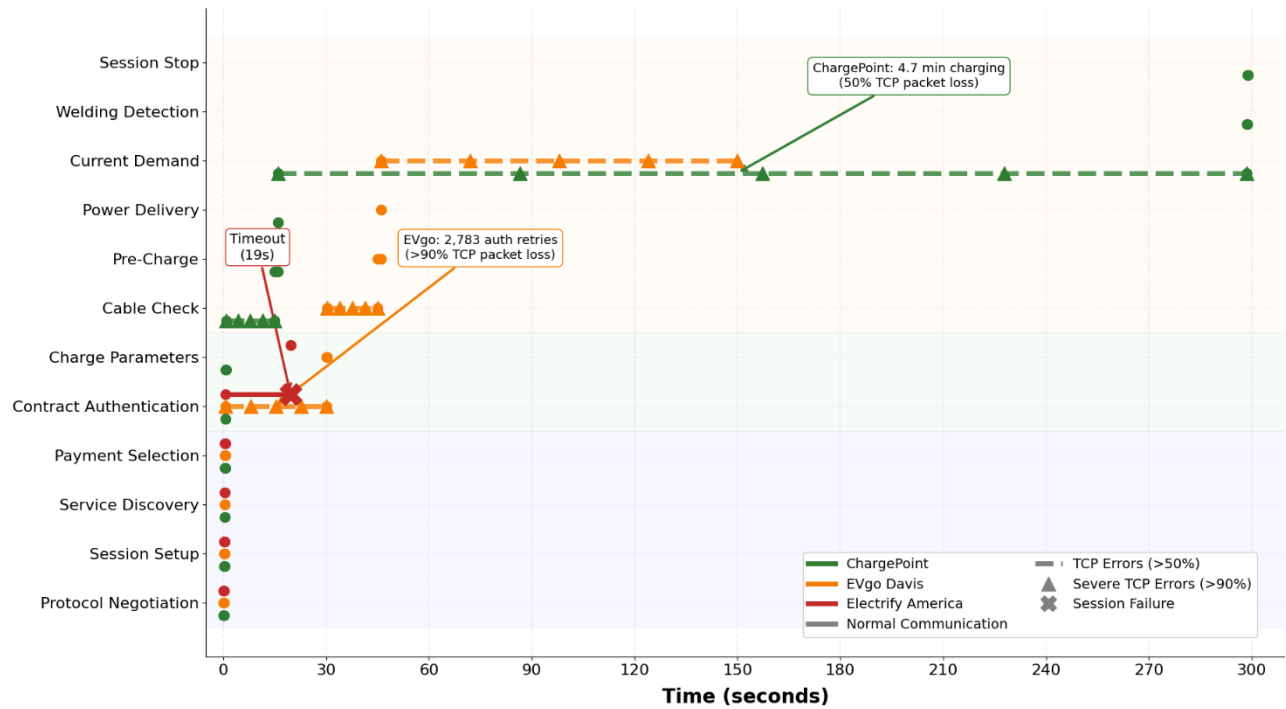
**Table 4.19: Detailed V2G Communication Phase Analysis**

V2G Phase	ChargePoint Sacramento	EVgo Davis	Electrify America (Davis and Sacramento)	Tesla (Davis and Tahoe)
<b>Protocol Negotiation</b>	Pass (143ms)	Pass	Pass	Fail
<b>Session Setup</b>	Pass (253ms)	Pass	Pass	-
<b>Service Discovery</b>	Pass (72ms)	Pass	Pass	-
<b>Payment Selection</b>	Pass (106ms)	Pass	Pass	-
<b>Contract Authentication</b>	Pass (110ms)	2,783 retries (93% TCP errors)	Timeout (19s)	-
<b>Charge Parameters</b>	Pass (110ms)	Pass	Pass	-
<b>Cable Check</b>	Pass (14.2s, 44% TCP errors)	Pass (95% TCP errors)	Not reached	-
<b>Pre-Charge</b>	Pass (895ms)	Pass (93% TCP errors)	Not reached	-

V2G Phase	ChargePoint Sacramento	EVgo Davis	Electrify America (Davis and Sacramento)	Tesla (Davis and Tahoe)
Power Delivery	Pass (84ms)	Started	Not reached	-
Current Demand	1,895 msggs (55% TCP errors)	401 msggs (92% TCP errors)	Not reached	-
Welding Detection	Pass (358ms)	Unknown	Not reached	-
Session Stop	Success	Unknown	Not reached	-

**Legend:**  = Successful completion |  = Completed with issues |  = Failed/Not reached | - = Not applicable

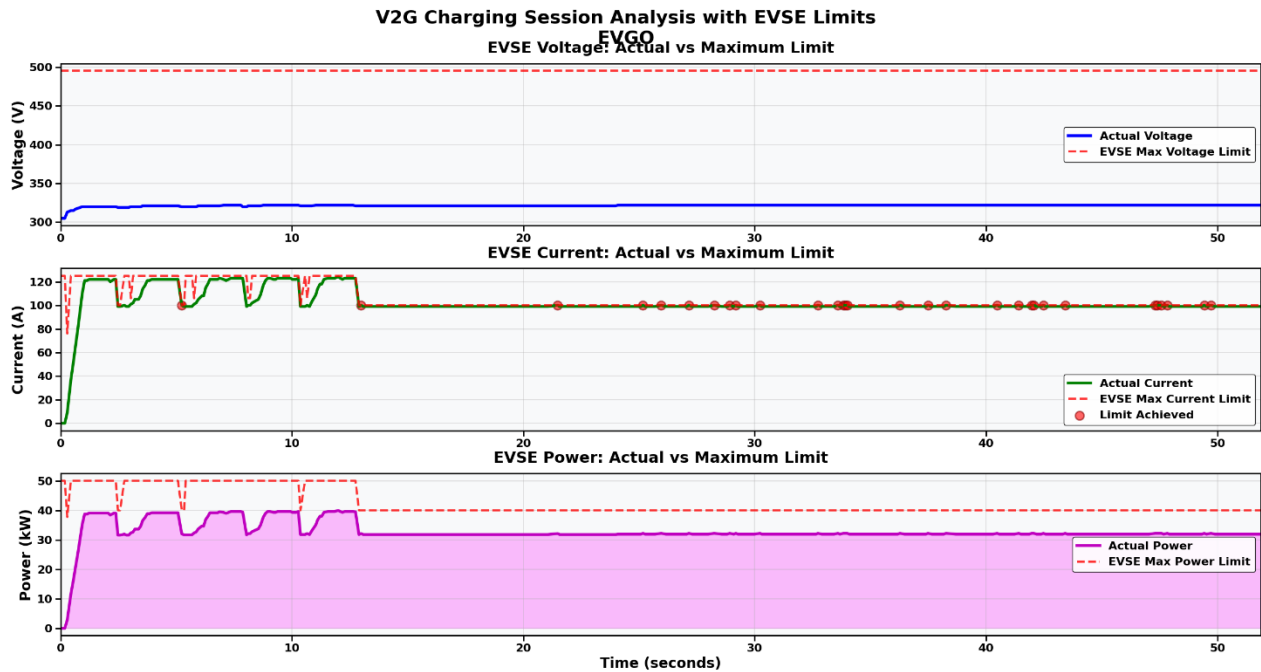
**V2G Communication Phase Progression Comparison EVES-6060-NA at Different Charging Networks**



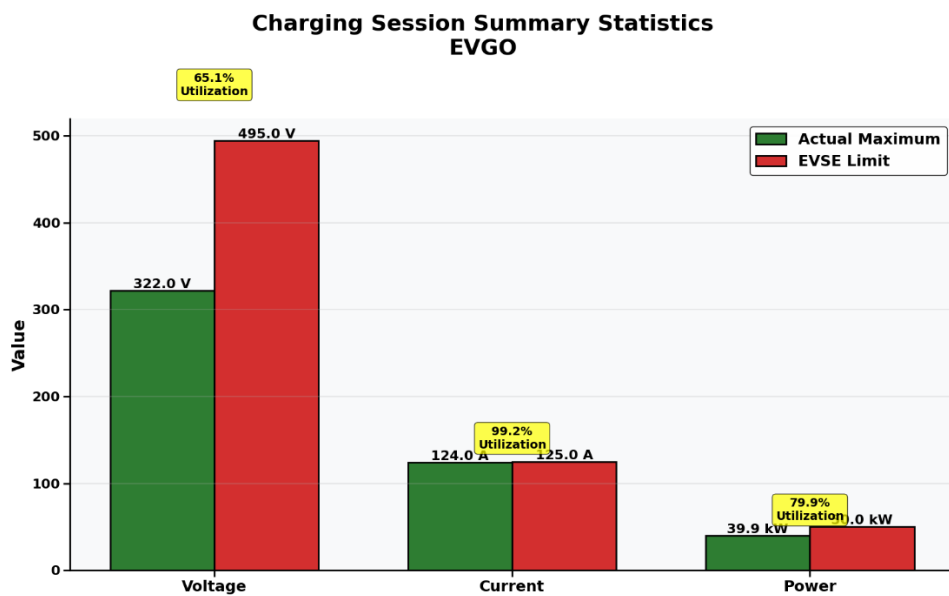
Data captured using Keysight PLC tracer and analyzed with Wireshark V2G plugin

**Figure 4.37: Comparative phase progression of V2G communications between EVES-6060-NA and different public DCFCs**

- The V2G communication protocol follows a structured sequence of phases, each serving a specific purpose. The PLC tracer results revealed distinct failure patterns for incompatible charging networks:
  - America (Davis and Sacramento locations): Analysis showed authentication protocol timeout after 19 seconds. The EVES-6060-NA successfully completed the initial handshake (SupportedAppProtocolRes, SessionSetupRes, ServiceDiscoveryRes) but failed during the ContractAuthenticationReq phase. This finding indicates certificate validation or protocol version incompatibility rather than a hardware issue.
  - EVGO Davis: While charging was achieved, PLC traces revealed severe TCP/IP communication degradation with > 90% packet loss across all message types. The station processed 2,783 authentication retry messages (compared to normal 1-2 messages), indicating infrastructure-level communication issues. Despite these challenges, the robust retry mechanism allowed the charging session to proceed. The severe communication issues (> 90% TCP packet loss) likely resulted in:
    - Unstable charging session with frequent communication retries
    - Extended session setup time due to 2,783 authentication attempts
    - Potential charging interruptions as the system struggled to maintain stable communication



**Figure 4.38: Current, voltage, and power of EVgo charging station captured through Keysight PLC tracer and their actual values vs. maximum limits of EVSE**

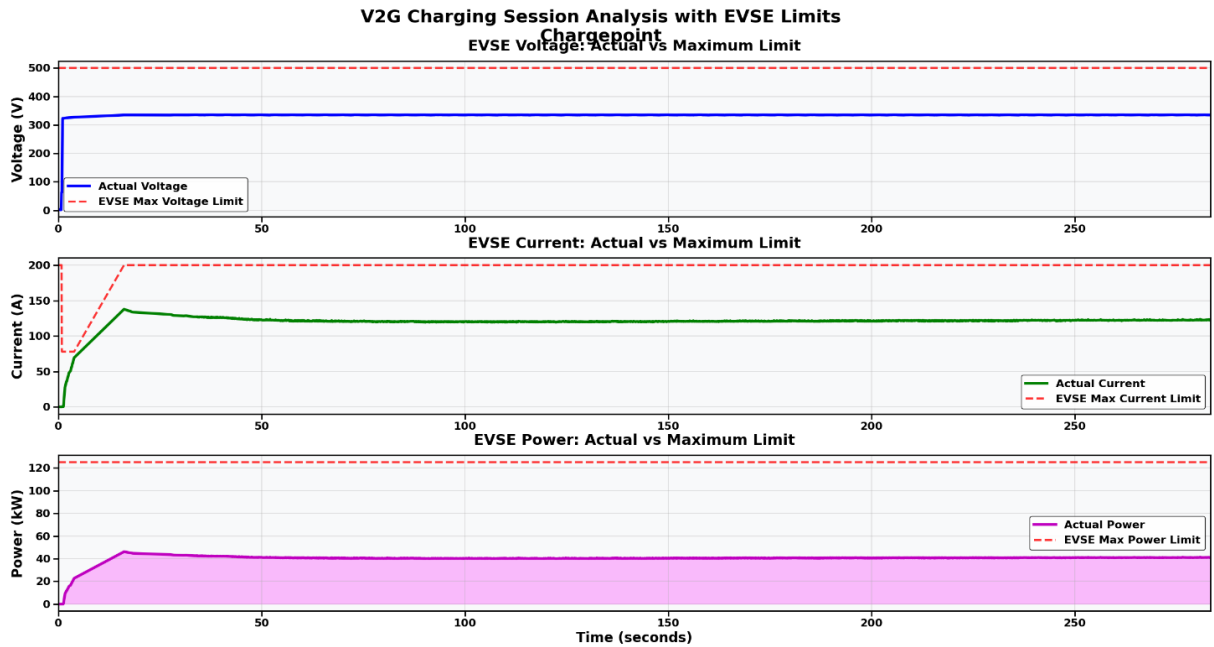


**Figure 4.39: EVgo session summary showing peak utilization and time-series comparison of voltage, current, and power against EVSE limits**

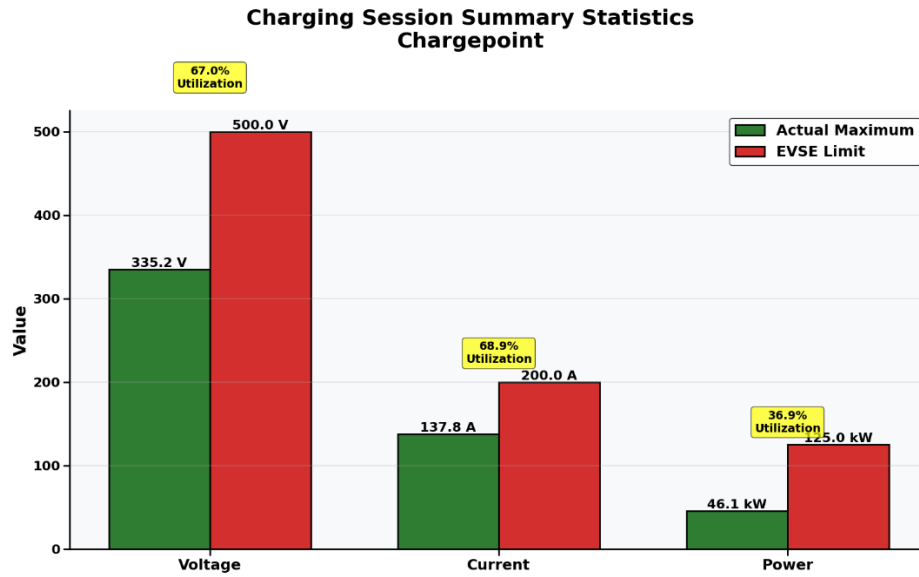
- ChargePoint West Sacramento: PLC analysis confirmed successful V2G communication with moderate TCP issues ( $\approx 50\%$  packet loss). The system completed all protocol phases, including 1,895

CurrentDemandRes messages over 4.7 minutes of active charging, demonstrating that the EVES-6060-NA V2G implementation functions correctly when the charging infrastructure supports proper error handling.

- Tesla Supercharger: Incompatibility was expected as Tesla's proprietary protocol differs from the CCS1/ISO 15118 standard implemented in the EVES-6060-NA, even when using NACS to CCS1 adapters.



**Figure 4.40: Current, voltage, and power of Chargepoint charging station captured through Keysight PLC tracer and their actual values vs. maximum limits of EVSE**



**Figure 4.41: ChargePoint session summary showing peak utilization and time-series comparison of voltage, current, and power against EVSE limits**

# Chapter 5:

## FreeWire Boost Charger 200 System Evaluation

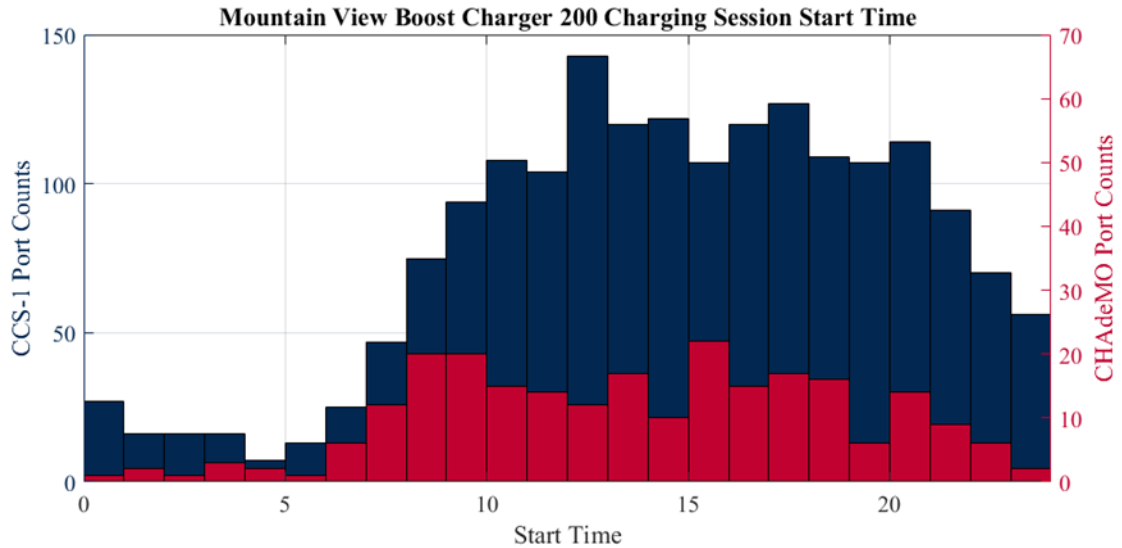
This chapter presents a comprehensive evaluation of the FreeWire Boost Charger 200. Despite the unit's delayed commissioning, we were able to gather historical operation data for three additional FreeWire Boost Charger 200 units in addition to the unit procured in this project. These included two chargers owned and operated by FreeWire in Mountain View and Morgan Hill, CA, and one unit owned by Fleet Services on the UC Davis campus.

The following sections detail the type of data available for each unit and offer a thorough statistical analysis of this information.

### Mountain View FreeWire Boost Charger 200 Evaluation

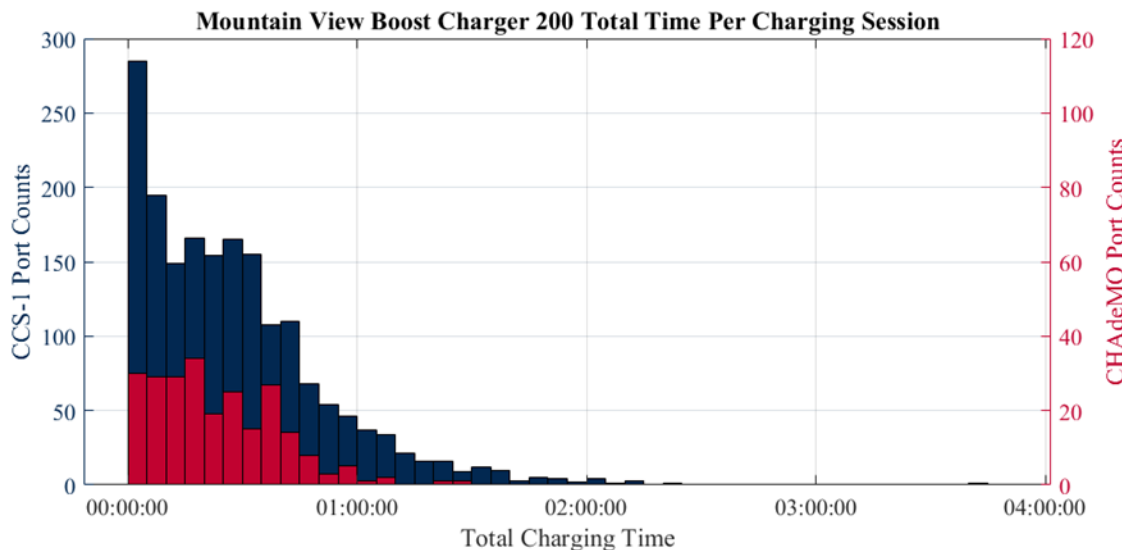
FreeWire operates a public Boost Charger 200 in Mountain View, CA for which they have provided usage data from March 2023 to June 2024. The unit has two ports, one of which has a CCS1 connector and the other a CHAdeMO connector. The available data include current, voltage, power, and energy transfer of each charging port as well as battery parameters, such as the SOC and the minimum and maximum cell temperature at time steps of roughly 20 seconds.

Figure 5.1 shows the times when charging sessions are initiated at the Mountain View charger. These times tend to be during daylight hours; although, there is some usage overnight. It can be seen that the CCS1 port is far more popular than the CHAdeMO port, likely due to the rarity of CHAdeMO-integrated EVs in California.



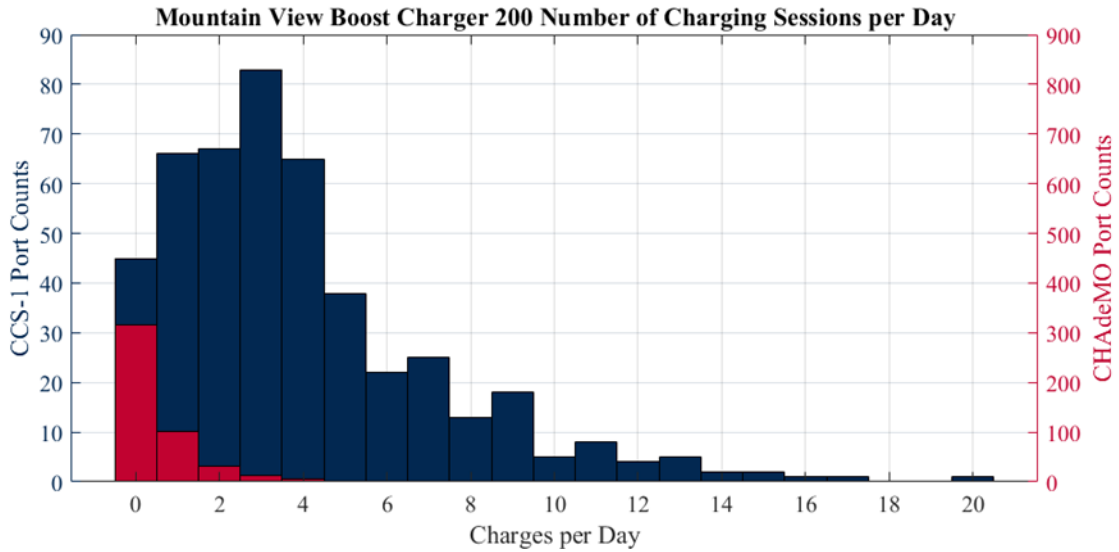
**Figure 5.1: Charging start times of the CCS1 and CHAdEMO ports of the Mountain View FreeWire Boost Charger 200**

Figure 5.2 describes the typical length of time for each charging session at the Mountain View FreeWire Boost Charger 200 for both port types. Ninety-one percent of charging sessions lasted less than one hour, but there were 10 charging sessions that lasted over 2 hours.



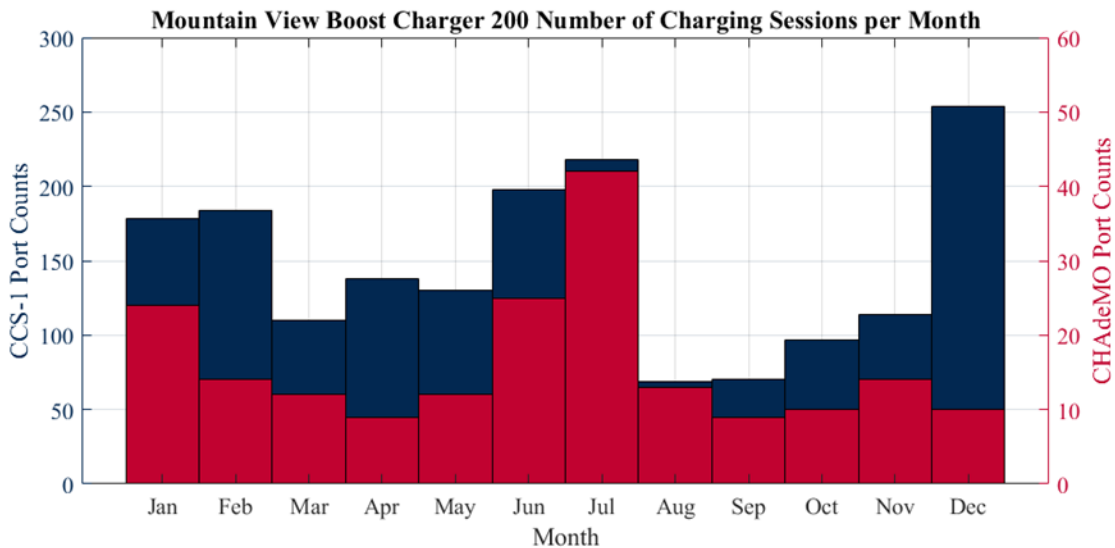
**Figure 5.2: Total charging session times of the CCS1 and CHAdEMO ports of the Mountain View FreeWire Boost Charger 200**

Figure 5.3 shows the charging session frequency per day for the entire historical data. A maximum of 20 charging sessions has been recorded in a day; nonetheless, a typical day included only three charging sessions for the CCS1 connector.



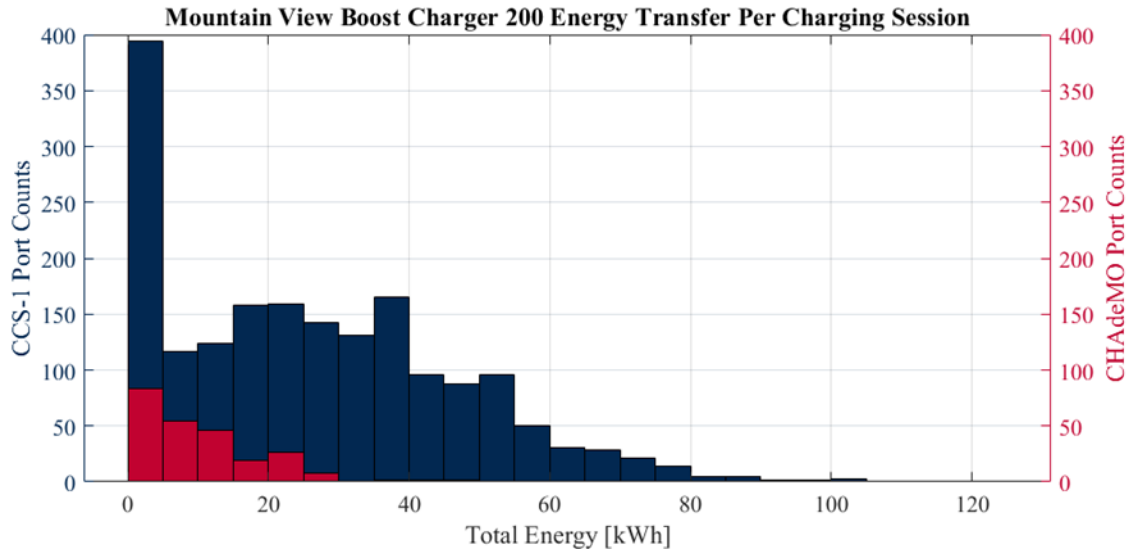
**Figure 5.3: Number of charging sessions per day of the CCS1 and CHAdeMO ports of the Mountain View FreeWire Boost Charger 200**

Figure 5.4 shows the charging session frequency per month for both ports. These statistics are from one year of usage data, from June 14, 2023, to June 13, 2024. The month of December had the maximum number of charging sessions for the CCS1 port, and July had the maximum charging sessions for the CHAdeMO connector.



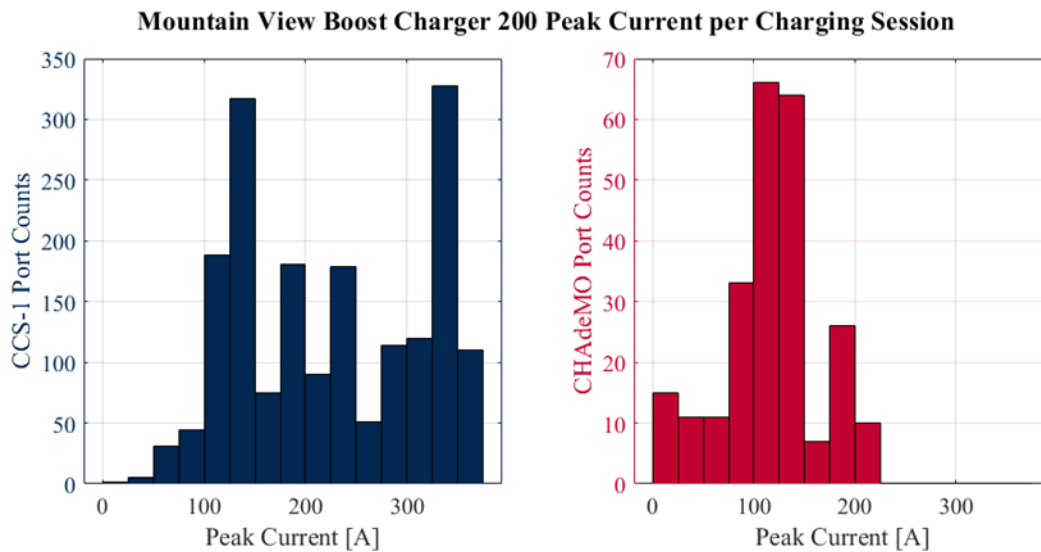
**Figure 5.4: Number of charging sessions per month of the CCS1 and CHAdeMO ports of the Mountain View FreeWire Boost Charger 200**

Figure 5.5 shows the total energy transferred during each charging session, which is less than 60 kWh in 94.5% of charging sessions.



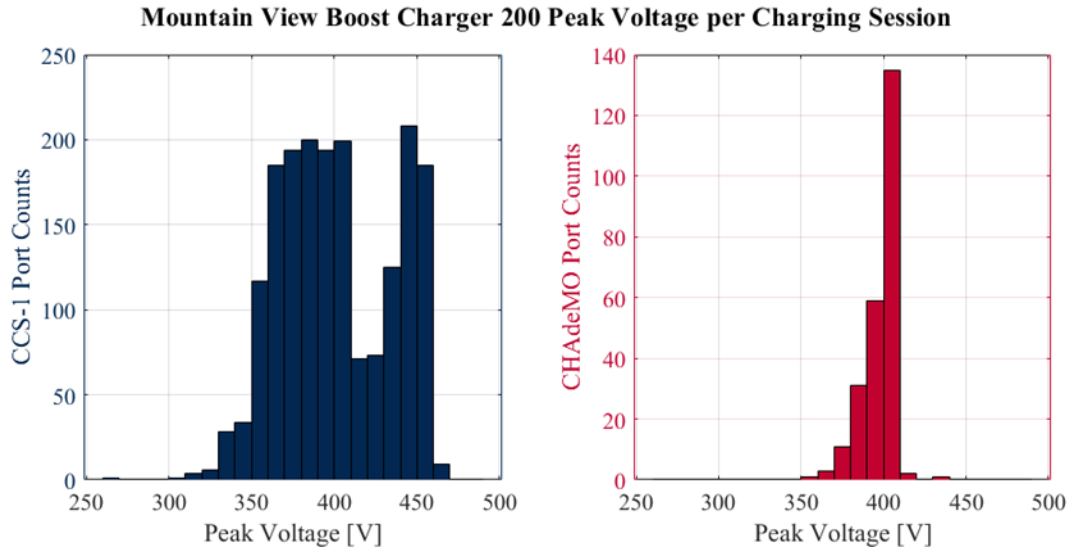
**Figure 5.5: Total energy transferred per charging session of the CCS1 and CHAdEMO ports of the Mountain View FreeWire Boost Charger 200**

Figure 5.6 shows the peak current during each charging session for both ports. The CHAdEMO port tends to provide lower currents than the CCS1 port.



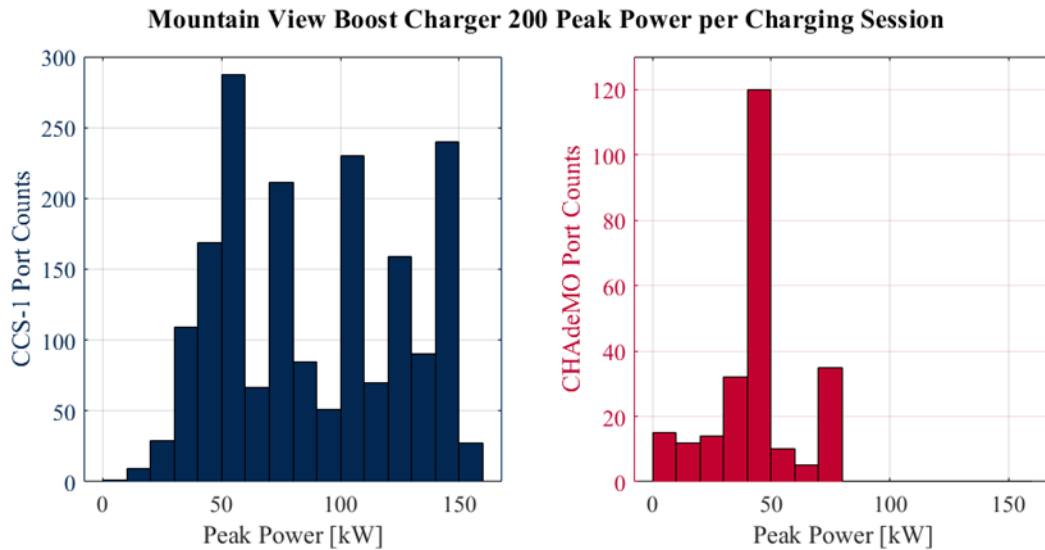
**Figure 5.6: Peak current per charging session of the CCS1 and CHAdEMO ports of the Mountain View FreeWire Boost Charger 200**

Figure 5.7 describes the peak voltage during each charging session, which has large clusters around 400 V for both ports. The CCS1 port also reaches 450 V often.



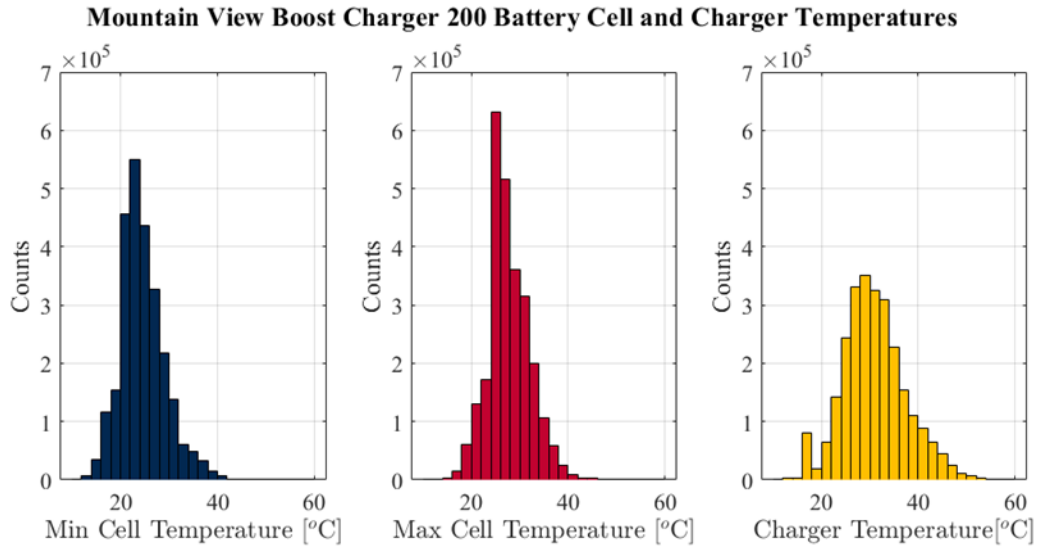
**Figure 5.7: Peak voltage per charging session of the CCS1 and CHAdeMO ports of the Mountain View FreeWire Boost Charger 200**

Figure 5.8 shows the peak power during each charging session. The CCS1 port provides up to 150 kW, and the CHAdeMO port provides up to 76 kW.



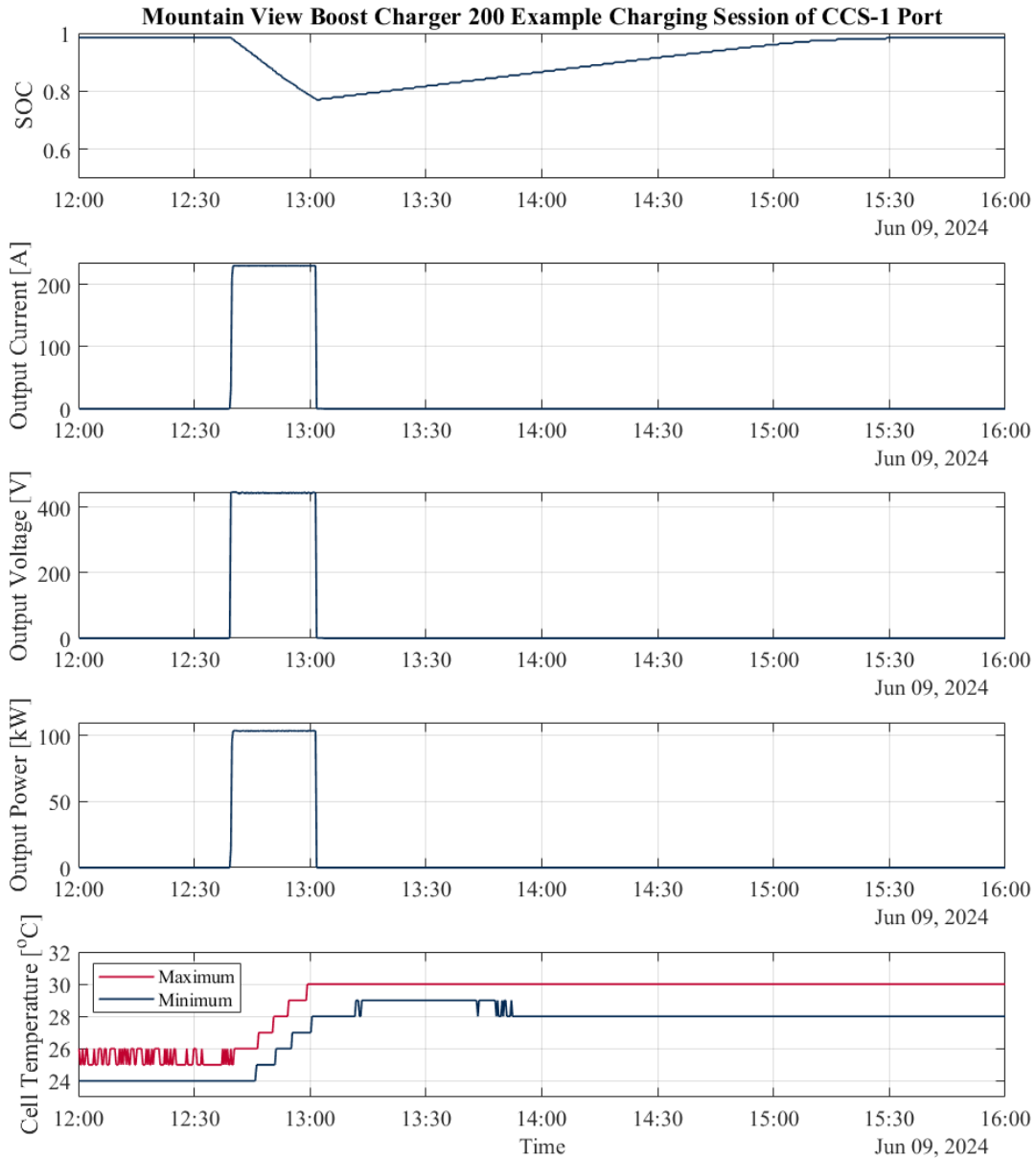
**Figure 5.8: Peak power per charging session of the CCS1 and CHAdeMO ports of the Mountain View FreeWire Boost Charger 200**

Figure 5.9 shows the statistics of the minimum and maximum battery cell temperatures over the whole usage dataset. The cell temperatures are contained between 10°C and 40°C other than a few outliers, but the charger temperature has a higher range up to 59°C.



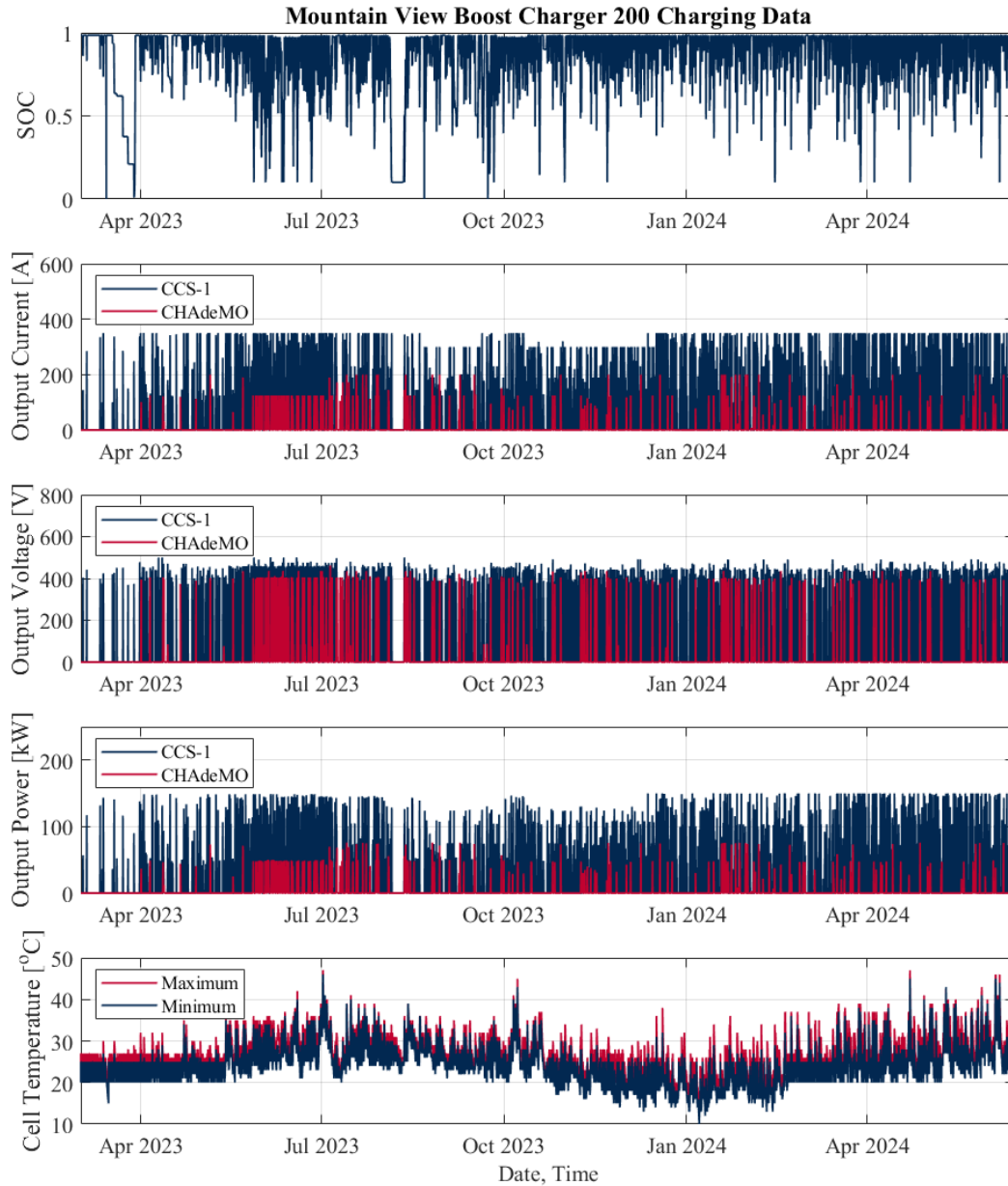
**Figure 5.9: The maximum and minimum cell temperatures and the charger temperature of the Mountain View FreeWire Boost Charger 200**

For one representative charging event, Figure 5.10 shows the Boost Charger 200 battery's SOC, minimum and maximum cell temperature as well as the charging current, voltage, and power. The battery SOC decreases as roughly 100 kW of power is provided to the vehicle, and once the charge is completed, it charges itself from its AC grid connection at a lower power. Thus, the SOC depleted from a 22-minute charging session is recharged in 2 hours and 28 minutes. The charging event raises the temperature of the entire battery by roughly 5°C.



**Figure 5.10: Battery SOC, output current, output voltage, output power, and cell temperatures for an example charging session of the CCS1 Port of the Mountain View FreeWire Boost Charger 200**

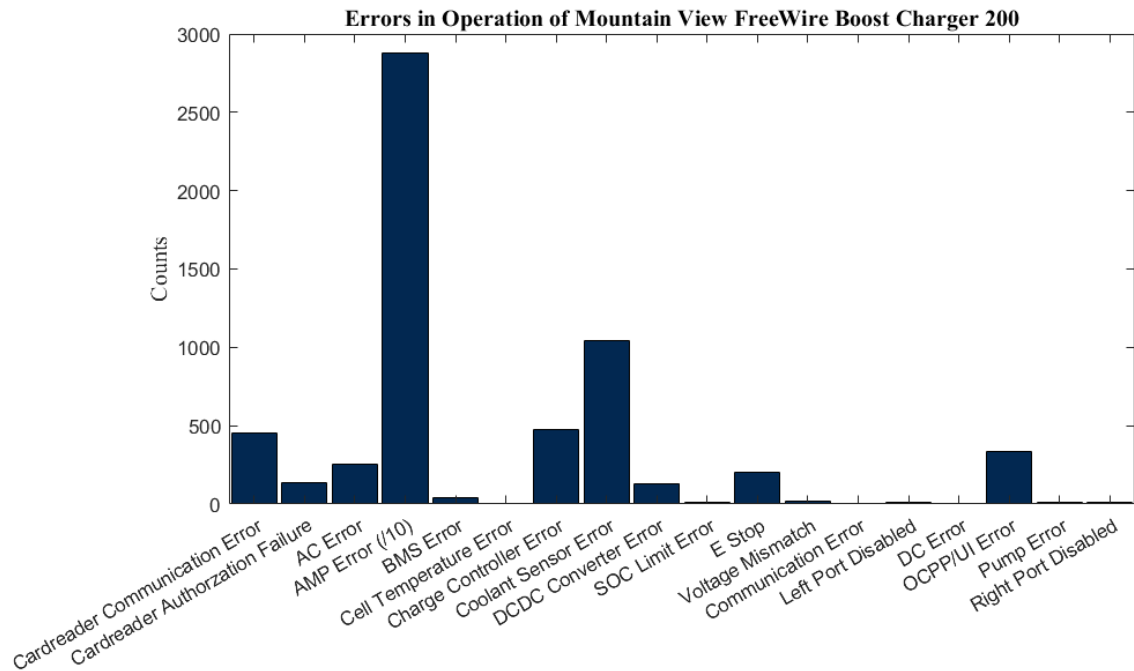
Figure 5.11 shows the Boost Charger 200 battery's SOC, charging current, voltage, power, and minimum and maximum cell temperature for the entire Mountain View location dataset. The data show the higher output current used by the CCS1 connector compared to the CHAdeMO port.



**Figure 5.11: Battery SOC, output current, output voltage, output power, and cell temperatures for the charging session data of the CCS1 and CHAdeMO ports of the Mountain View FreeWire Boost Charger 200**

The data available from the FreeWire operation includes error messages, which have been tabulated in Figure 5.12. The most common error codes relate to software problems, such as card-reader errors, AMP, and open charge point protocol (OCPP) communication issues. Other errors relate to cell temperatures that are too low or high for operation, or errors with the coolant temperature.

Electrical operation errors manifest in issues with the AC input, battery management system (BMS), charge controller, and DCDC converter.

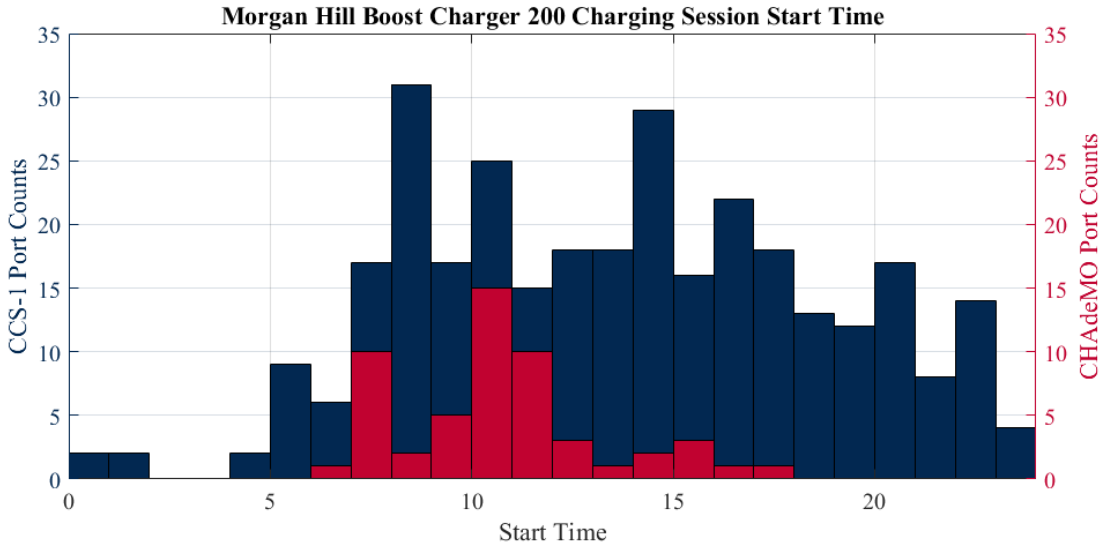


**Figure 5.12: Error codes during historical operation of the Mountain View FreeWire Boost Charger 200**

## Morgan Hill FreeWire Boost Charger 200 Evaluation

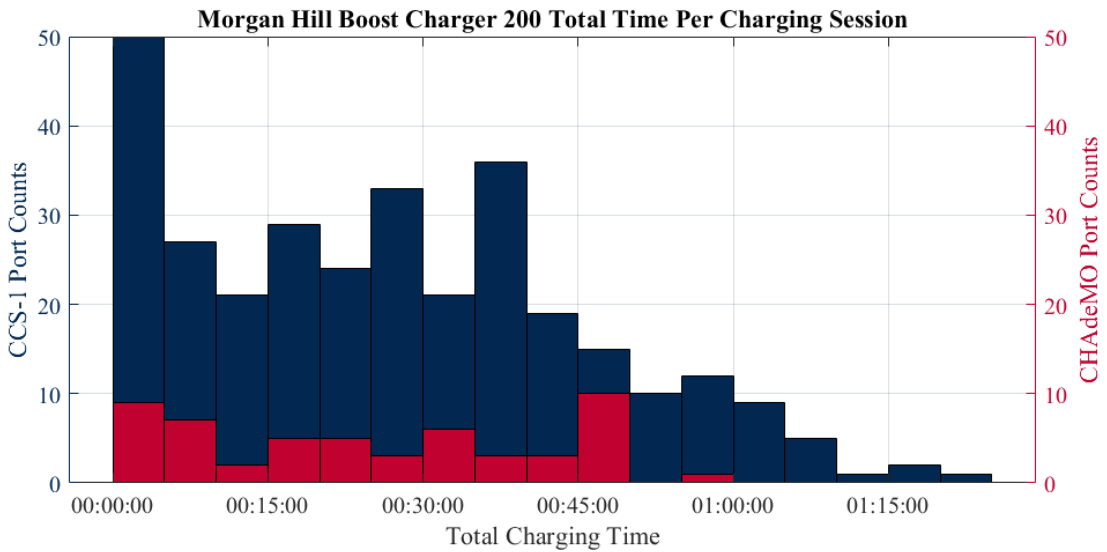
FreeWire operates a public Boost Charger 200 in Morgan Hill, CA, for which they have provided usage data since it was installed in March 2024 until June 2024. The unit has two ports, one of which has a CCS1 connector and the other a CHAdeMO connector. The type and resolution of these data are the same as the Mountain View unit.

Figure 5.13 shows the times for which charging sessions are initiated at the Morgan Hill charger. These tend to be during daylight hours, and there is almost no usage in the early hours of the morning. It can be seen that the CCS1 port is far more popular than the CHAdeMO port, likely due to the rarity of CHAdeMO-integrated EVs in California.



**Figure 5.13: Charging start times of the CCS1 and CHAdeMO ports of the Morgan Hill FreeWire Boost Charger 200**

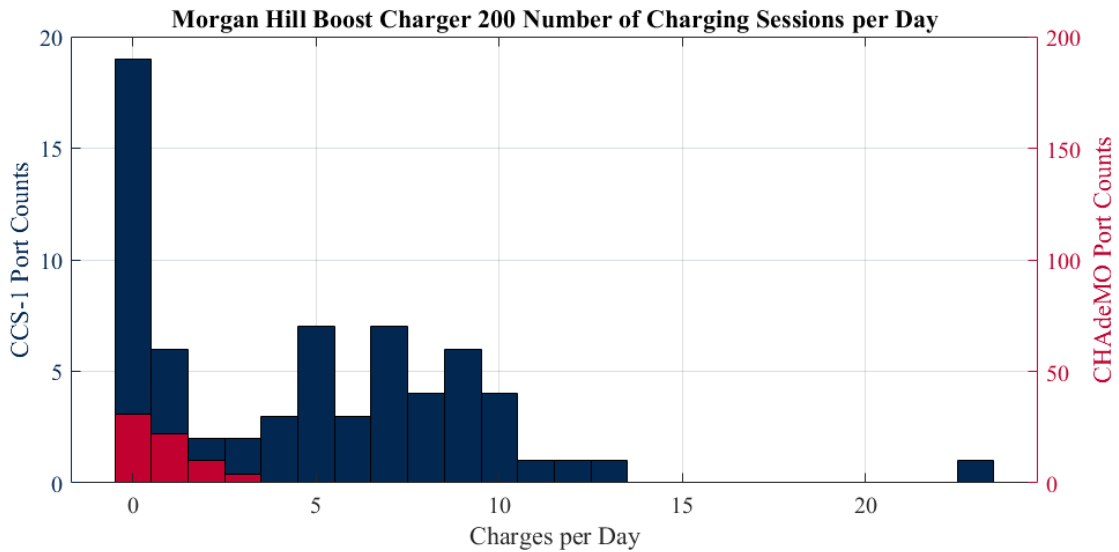
Figure 5.14 describes the typical length of time for each charging session at the Morgan Hill FreeWire Boost Charger 200 for both port types. Eighty-two percent of charging sessions last less than 45 minutes, but there are three charging sessions that last over 1 hour and 15 minutes.



**Figure 5.14: Total charging session times of the CCS1 and CHAdeMO ports of the Morgan Hill FreeWire Boost Charger 200**

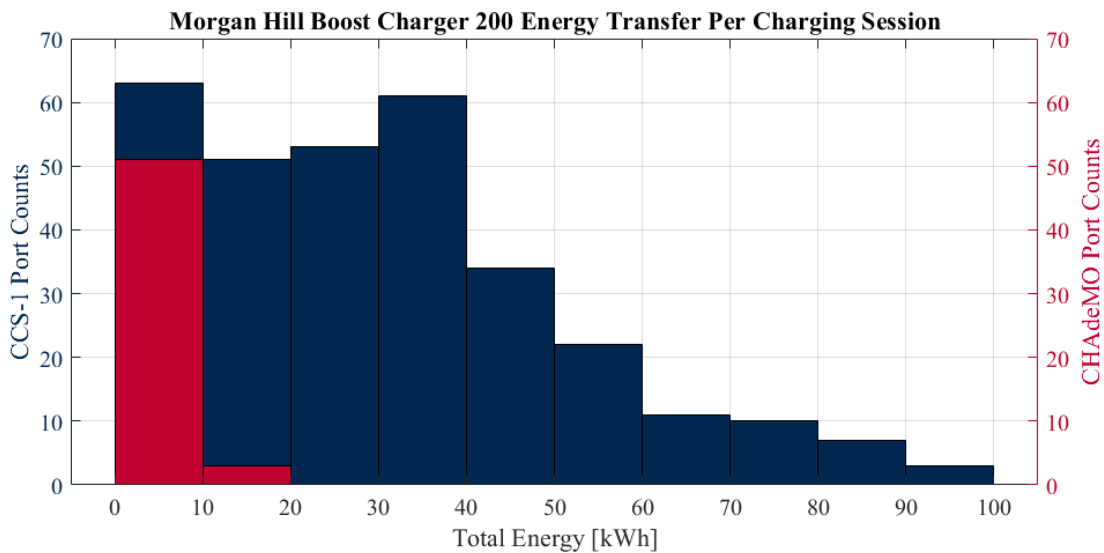
Figure 5.15 shows the charging session frequency per day for the whole of the historical data. For the CCS1 port, 28% of days have no charging session

initiated, but there is one day with 23 charging sessions. Forty-six percent of days have no charging session initiated for the CHAdeMO connector.



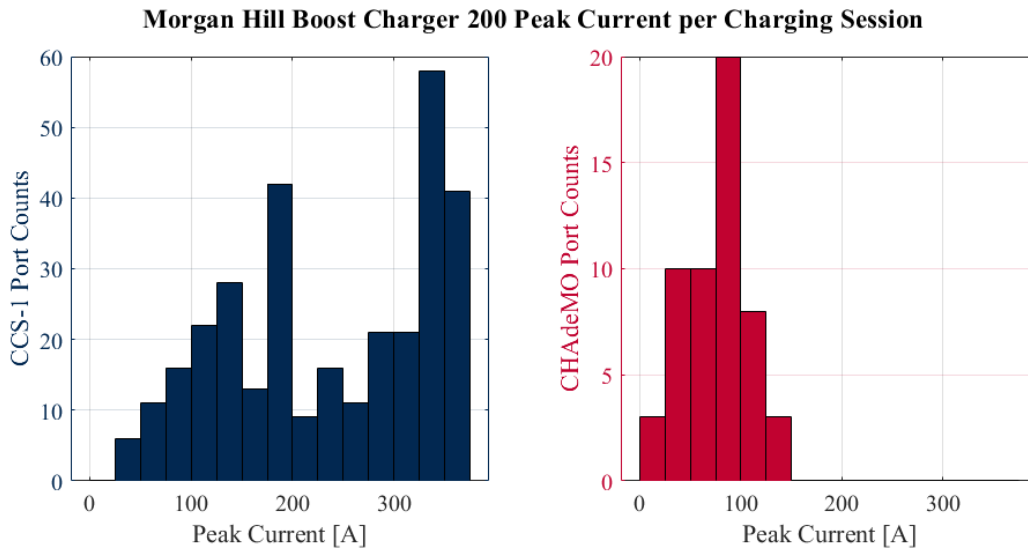
**Figure 5.15: Number of charging sessions per day of the CCS1 and CHAdeMO ports of the Morgan Hill FreeWire Boost Charger 200**

Figure 5.16 shows the total energy transferred during each charging session, which is 60 kWh or less 90% of the time. The CHAdeMO port sees very short charging session with only up to 20 kWh of energy transfer.

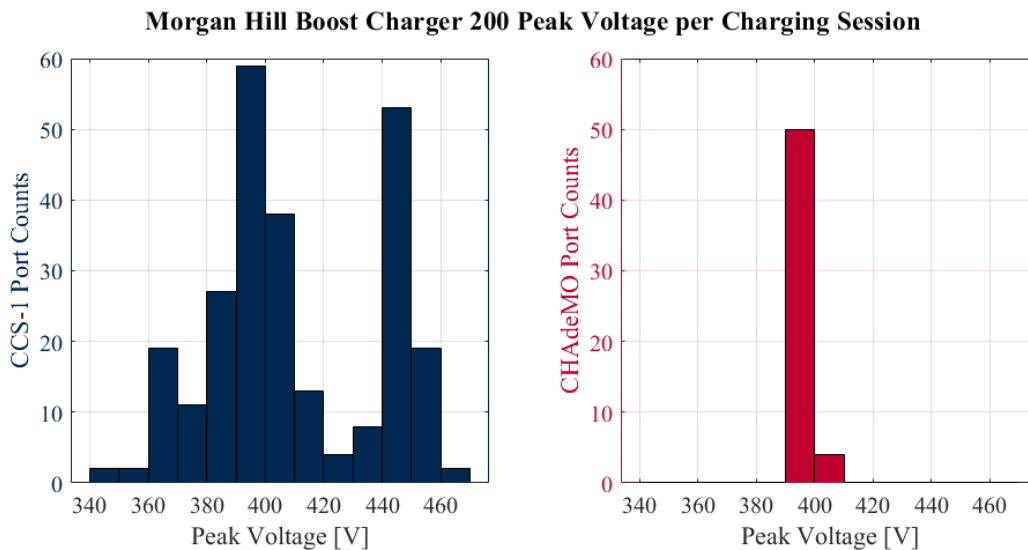


**Figure 5.16: Total energy transferred per charging session of the CCS1 and CHAdeMO ports of the Morgan Hill FreeWire Boost Charger 200**

Figure 5.17 shows the peak current during each charging session for both ports. The CHAdeMO port tends to provide lower currents than the CCS1 port.

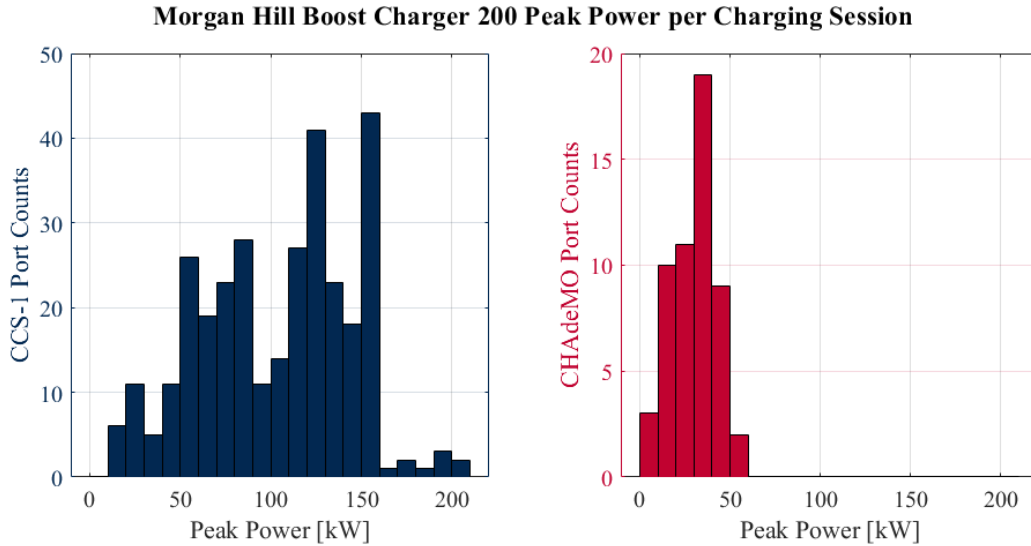


**Figure 5.17: Peak current per charging session of the CCS1 and CHAdeMO ports of the Morgan Hill FreeWire Boost Charger 200**



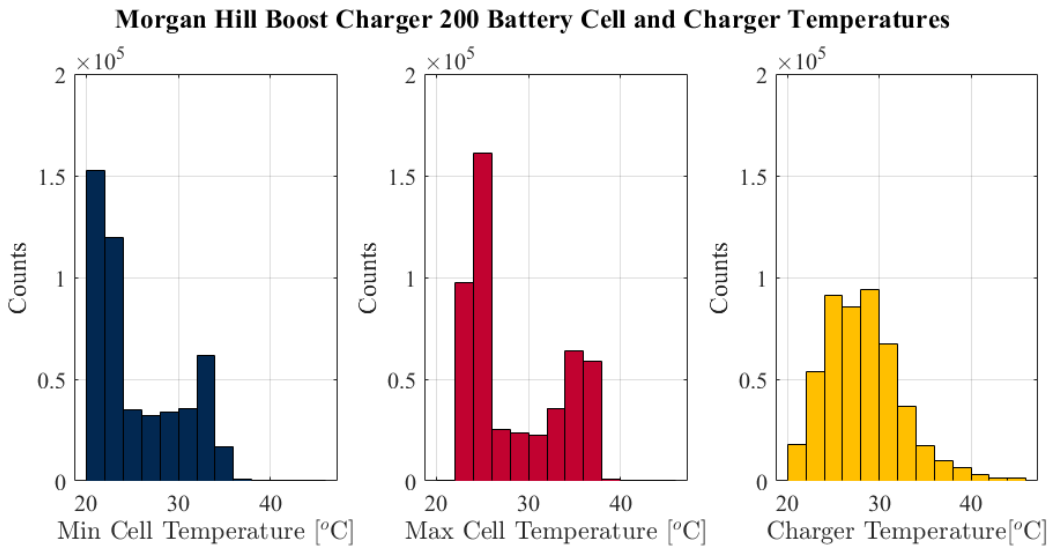
**Figure 5.18: Peak voltage per charging session of the CCS1 and CHAdeMO ports of the Morgan Hill FreeWire Boost Charger 200**

Figure 5.19 shows the peak power during each charging session. The CCS1 port often provides up to around 150 kW but can exceed 200 kW, and the CHAdeMO port provides up to around 60 kW.



**Figure 5.19: Peak power per charging session of the CCS1 and CHAdeMO ports of the Morgan Hill FreeWire Boost Charger 200**

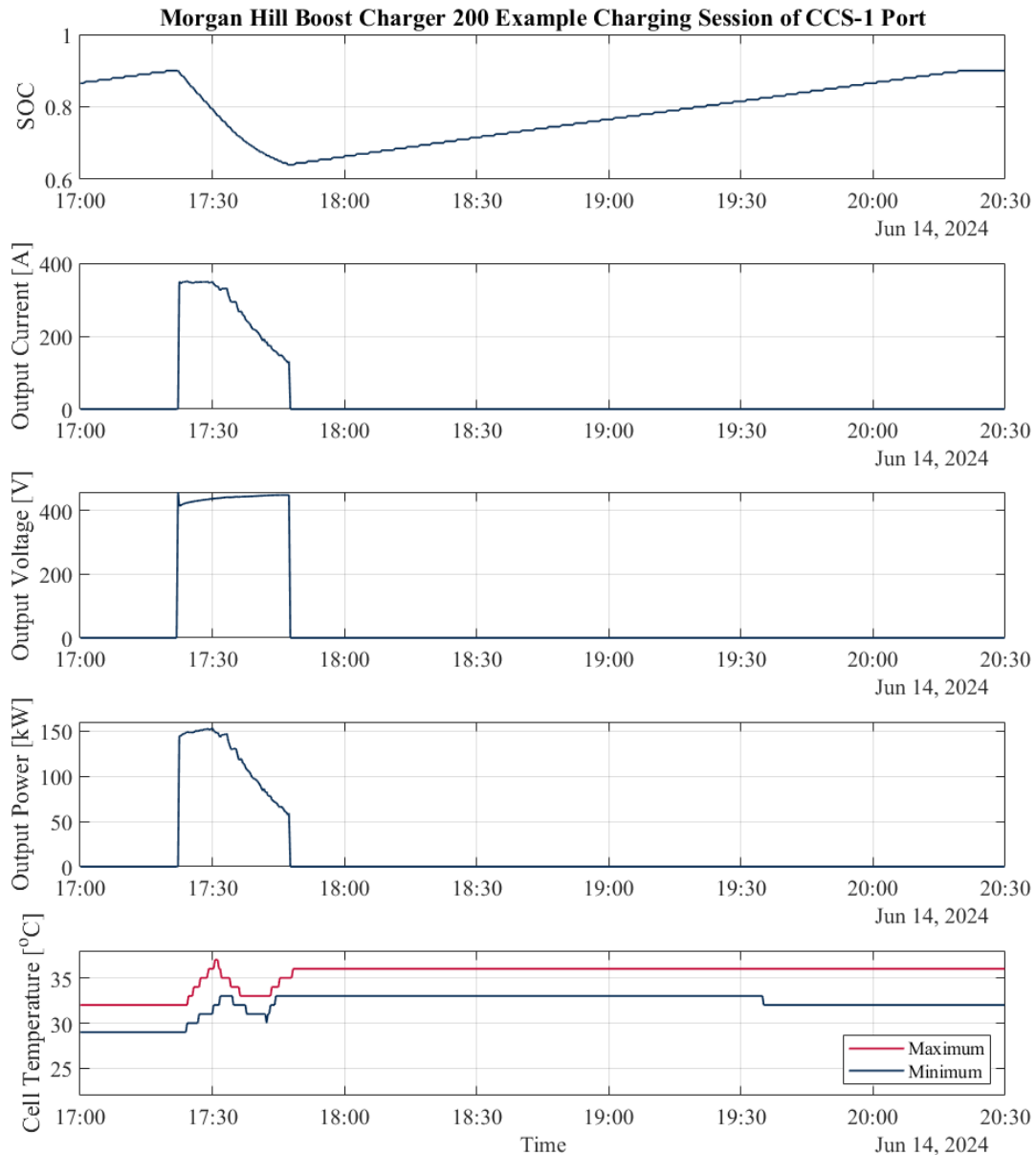
Figure 5.20 shows the statistics of the minimum and maximum battery cell temperatures over the full set of usage data. The cell temperatures range from 20°C and 40°C, but the charger temperature has a higher range up to 46°C.



**Figure 5.20: The maximum and minimum cell temperatures and the charger temperature of the Morgan Hill FreeWire Boost Charger 200**

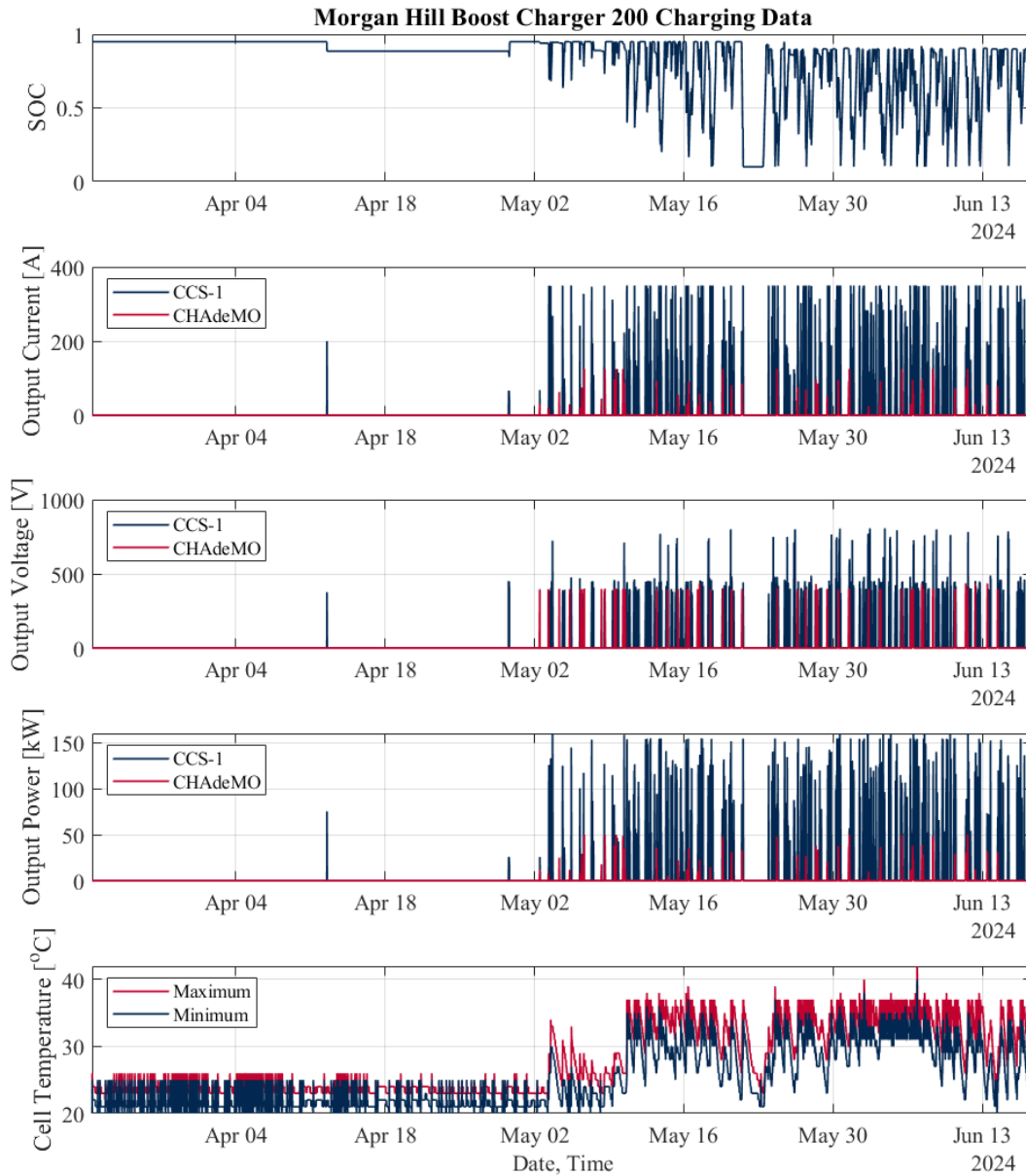
For one representative charging event, Figure 5.21 shows the Boost Charger 200 battery's SOC, minimum and maximum cell temperature as well as the charging current, voltage, and power. The FreeWire Boost Charger 200 uses the grid to charge it up to its setpoint of 0.9, and then the SOC of the battery

decreases as roughly 150 kW of power is provided to the vehicle. Once the charge is completed, it charges itself from its AC grid connection at a lower power. Thus, the SOC depleted from a 25-minute charging session is recharged in 2 hours and 48 minutes. The charging event raises the temperature of the entire battery by roughly 4°C.



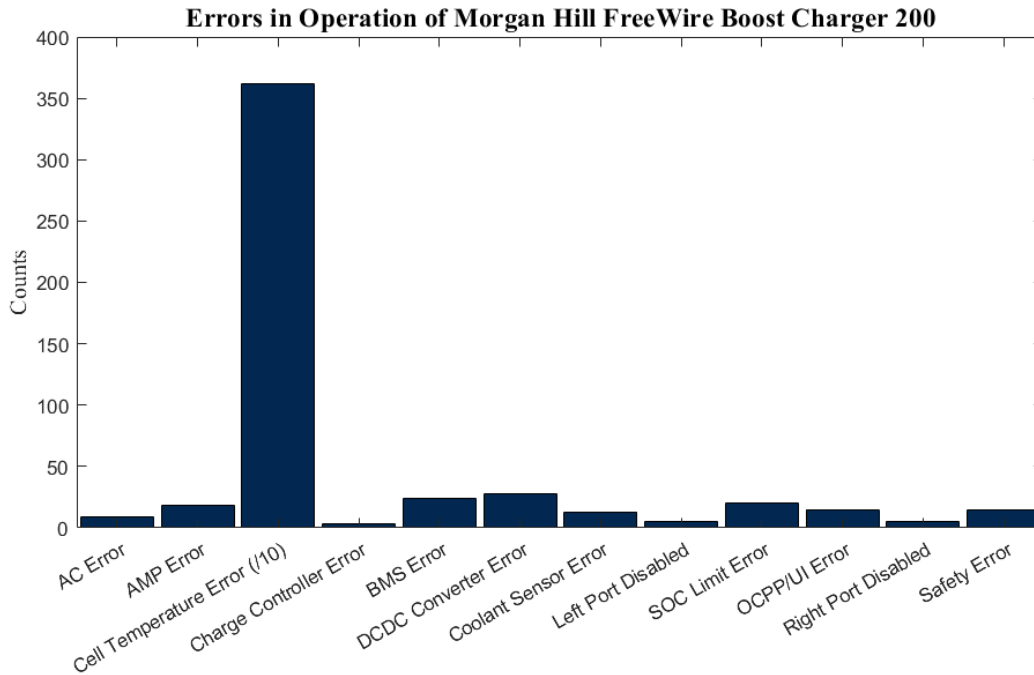
**Figure 5.21: Battery SOC, output current, output voltage, output power, and cell temperatures for an example charging session of the CSS-1 Port of the Morgan Hill FreeWire Boost Charger 200**

Figure 5.22 shows the Boost Charger 200 battery's SOC, charging current, voltage, power, and minimum and maximum cell temperature for the entire set of data for the Morgan Hill location. The charger was used very infrequently for the first month that it was operational, likely due to being unknown by EV users in the area. The data show the higher output current used by the CCS1 connector compared to the CHAdeMO port.



**Figure 5.22: Battery SOC, output current, output voltage, output power, and cell temperatures for the charging session data of the CCS1 and CHAdeMO ports of the Morgan Hill FreeWire Boost Charger 200**

The data available from the FreeWire operation includes error messages, which have been tabulated in Figure 5.23. The most common error codes relate to cell temperature problems. Other errors are the result of electrical issues with the AC power, BMS, charge controller, and DCDC converter or communication issues with AMP and OCPP. An error can also result from a SOC limit being reached or a safety issue.

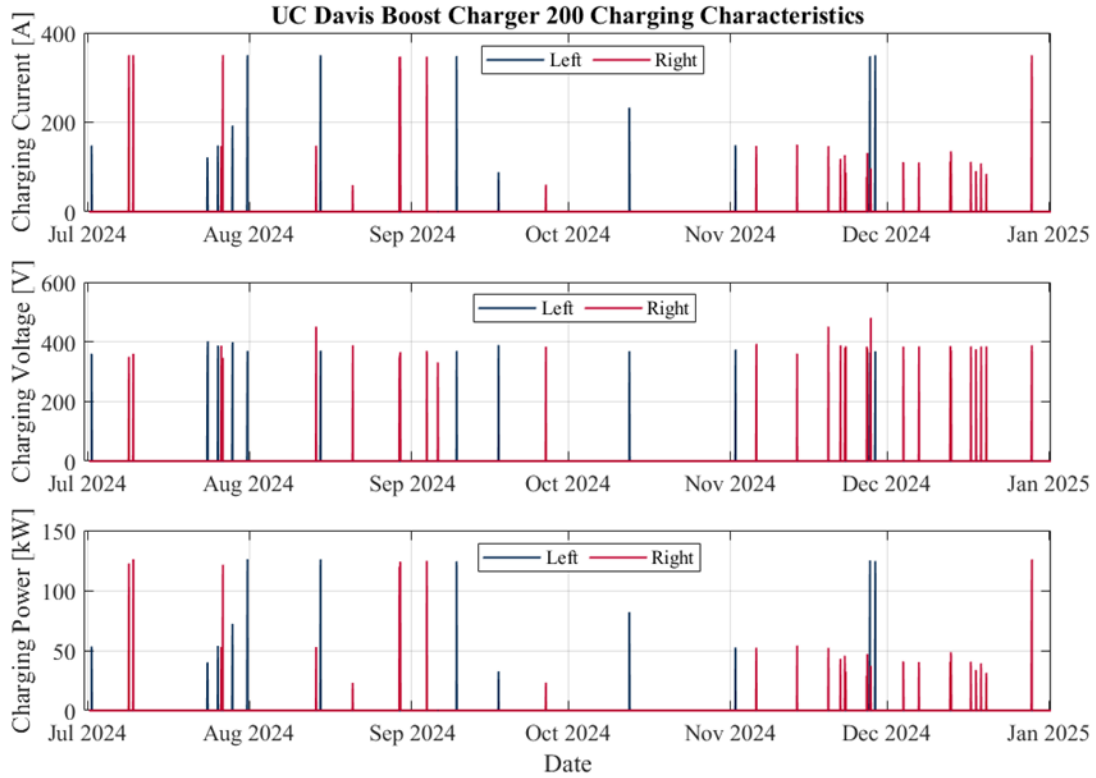


**Figure 5.23: Error codes during historical operation of the Morgan Hill FreeWire Boost Charger 200**

## UC Davis FreeWire Boost Charger 200 Evaluation

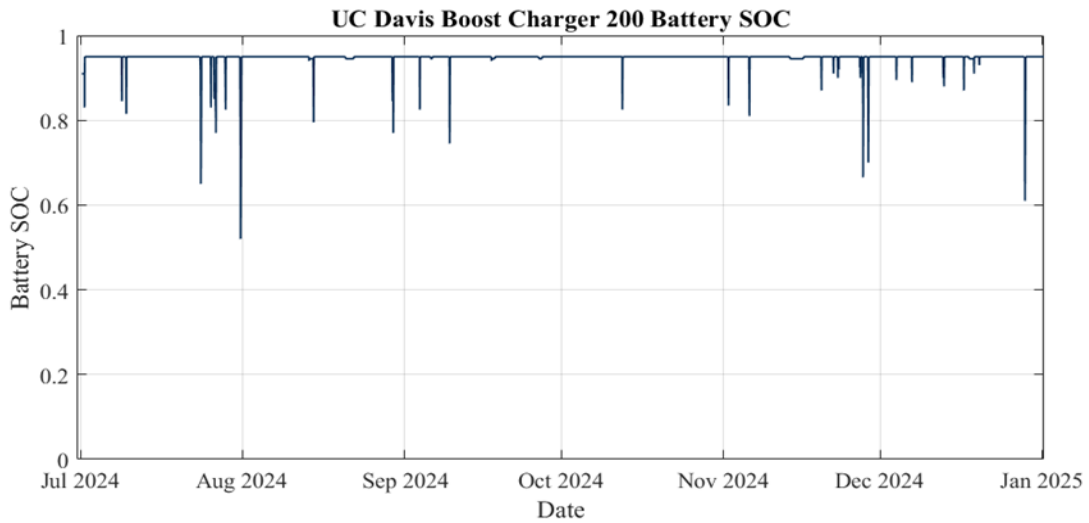
In summer 2024, UC Davis Fleet Services purchased and installed a FreeWire Boost Charger 200 unit on campus that has two CCS1 type charging ports. This unit is not a public charger and is specifically used by UC Davis Fleet Services to charge their EVs. Usage data were provided by FreeWire for July 2024 to December 2024 and follow the same data and resolution patterns as seen with the public chargers in Mountain View and Morgan Hill.

Figure 5.24 shows the charging current, voltage, and power for the entire six-month dataset, elucidating the pattern of infrequent usage. The figure shows the charging events provided from the left and right charging port, both of which are CCS1 connectors.



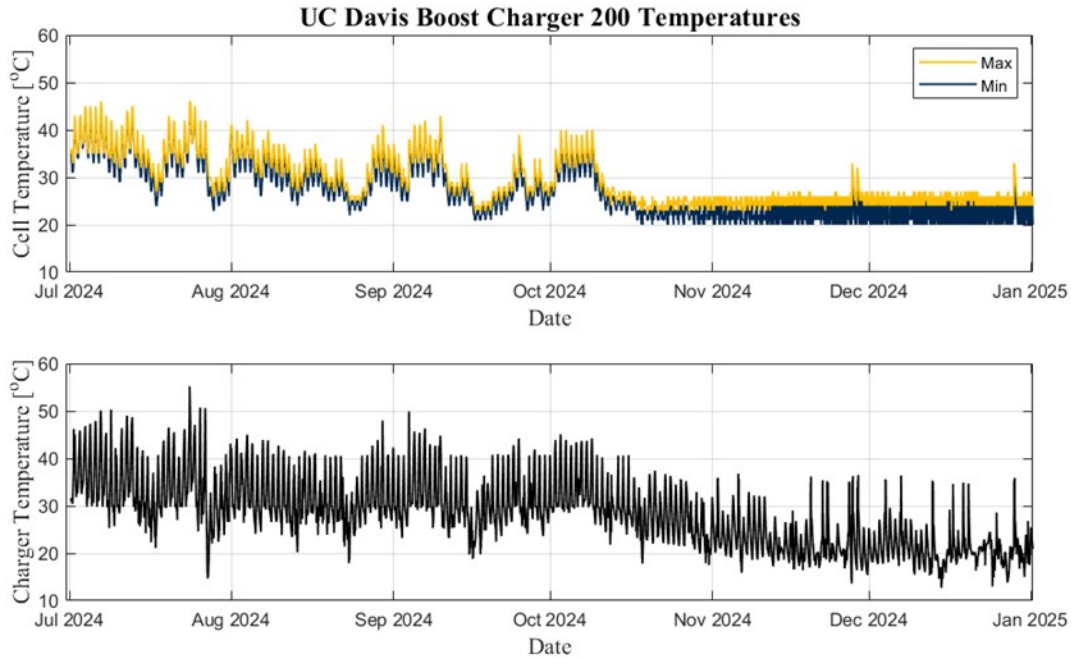
**Figure 5.24: Charging current, voltage, and power of both CCS1 ports of the FreeWire Boost Charger 200 installed on UC Davis campus**

Figure 5.25 shows the SOC of the Boost Charger 200 integrated battery. The low levels of usage mean that the battery is often at a high SOC value and is never discharged below 0.5 or 50%.



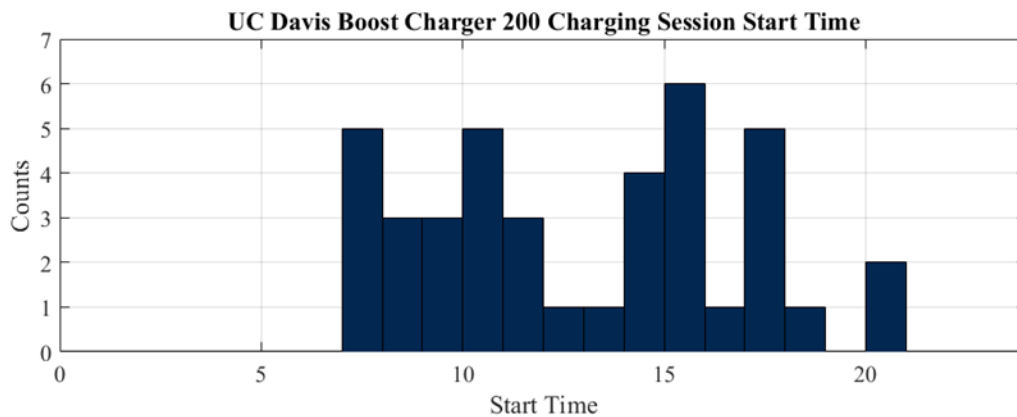
**Figure 5.25: SOC of the FreeWire Boost Charger 200 installed on UC Davis campus**

Figure 5.26 shows the minimum and maximum battery cell temperatures as well as the temperature of the charger itself. The temperatures vary in the warmer summer months, but in the later winter months they are more constant. The temperatures of the system are impacted by the outside ambient temperature much more than from charging.



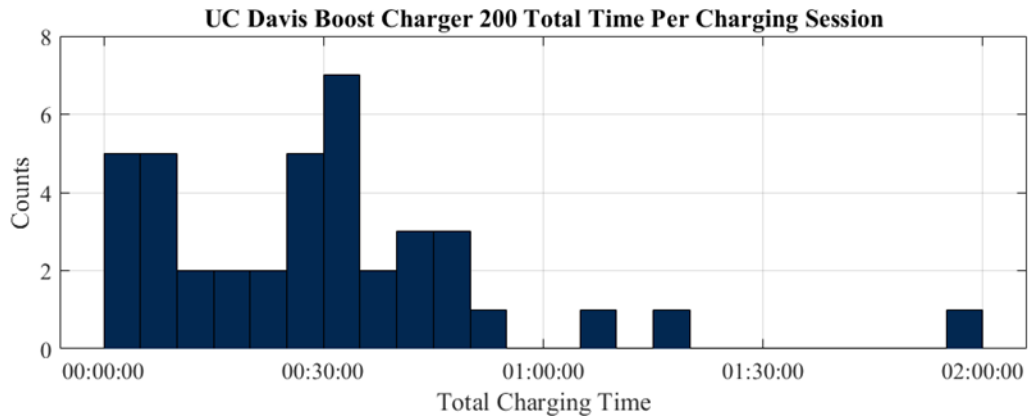
**Figure 5.26: The maximum and minimum cell temperatures and the charger temperature of the FreeWire Boost Charger 200 installed on UC Davis campus**

The times when charging sessions are initiated can be seen in Figure 5.27. Charging sessions occur during work hours or just afterward when vehicles were returned to Fleet Services.



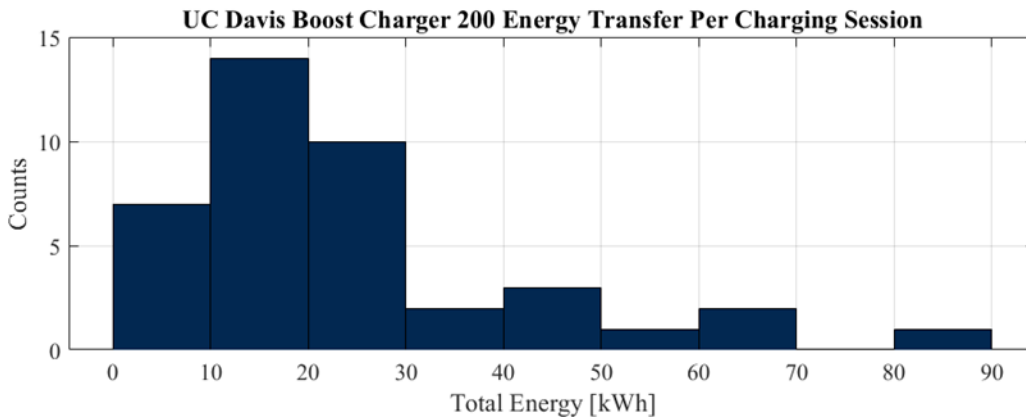
**Figure 5.27: Charging start times of the FreeWire Boost Charger 200 installed on UC Davis campus**

Figure 5.28 describes the typical length of time for each charging session at the UC Davis FreeWire Boost Charger 200; 92.5% of charging sessions last less than one hour.



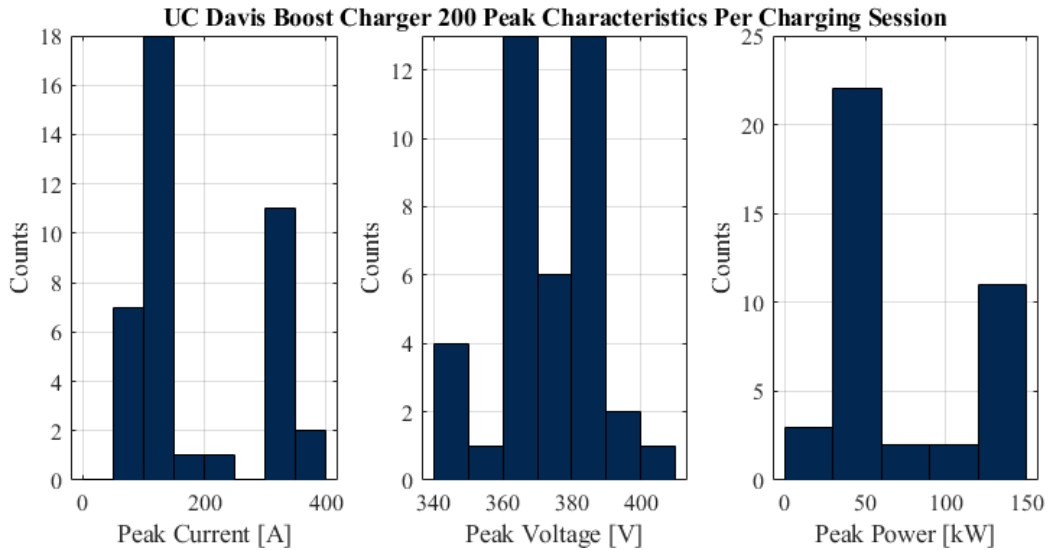
**Figure 5.28: Total charging session times of the FreeWire Boost Charger 200 installed on UC Davis campus**

Figure 5.29 shows the total energy transferred during each charging session, which is 30 kWh or less in 77.5% of charging sessions.



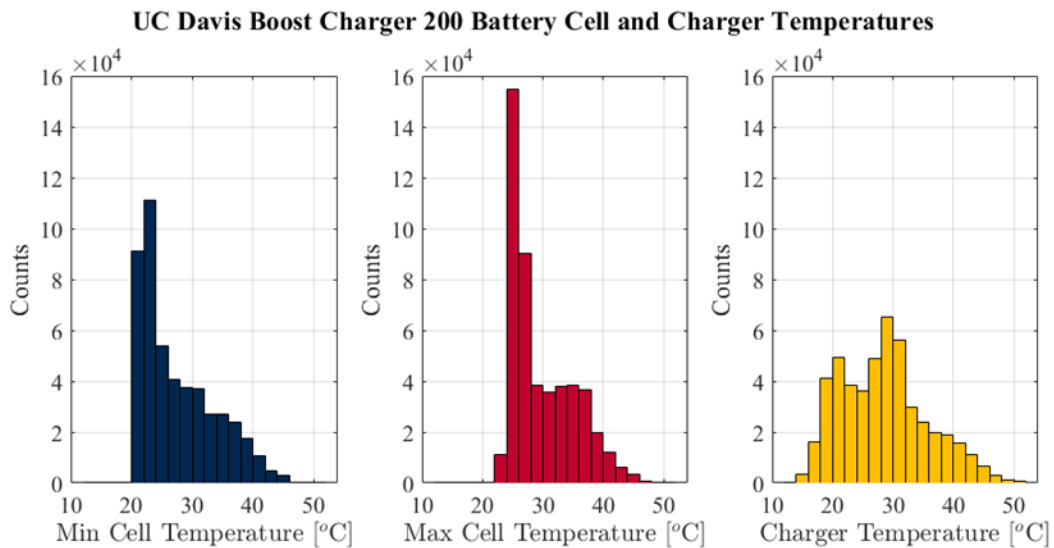
**Figure 5.29: Total energy transferred per charging session of the FreeWire Boost Charger 200 installed on UC Davis campus**

Figure 5.30 shows the peak current, voltage, and power of each charging session. The BMS of the EV controls the power, and therefore, current requested from the charger, so the higher power charging sessions likely correspond to the larger F150 Lightning owned by UC Davis Fleet Services, while the lower power charging sessions correspond to smaller EVs.



**Figure 5.30: The peak current, voltage, and power of each charging session of the FreeWire Boost Charger 200 installed on UC Davis campus**

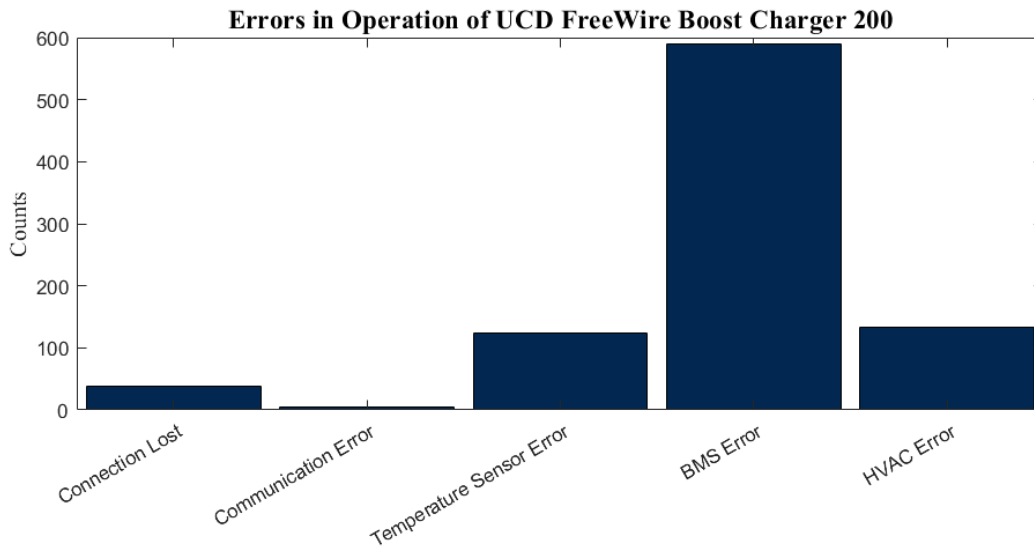
In Figure 5.31, the temperature statistics of the FreeWire Boost Charger 200 installed on UC Davis campus can be seen. Overall, the minimum and maximum cell temperatures tend to be steady at their minimum values of 20°C and 24°C respectively, but the temperature of the whole charger varies significantly more.



**Figure 5.31: The maximum and minimum cell temperatures and the charger temperature of the FreeWire Boost Charger 200 installed on UC Davis campus**

The error messages associated with the operation of the UC Davis Campus FreeWire unit are shown in Figure 5.32. Since there is no payment

needed for the private device, there are no card-reader errors, and the majority of errors are from the BMS. Other significant errors relate to the temperature and heating, ventilation, and air conditioning (HVAC) sensors. There are some errors that relate to problems with the connection and communication; although, most of these errors resolve themselves and do not result in a lack of charging ability.

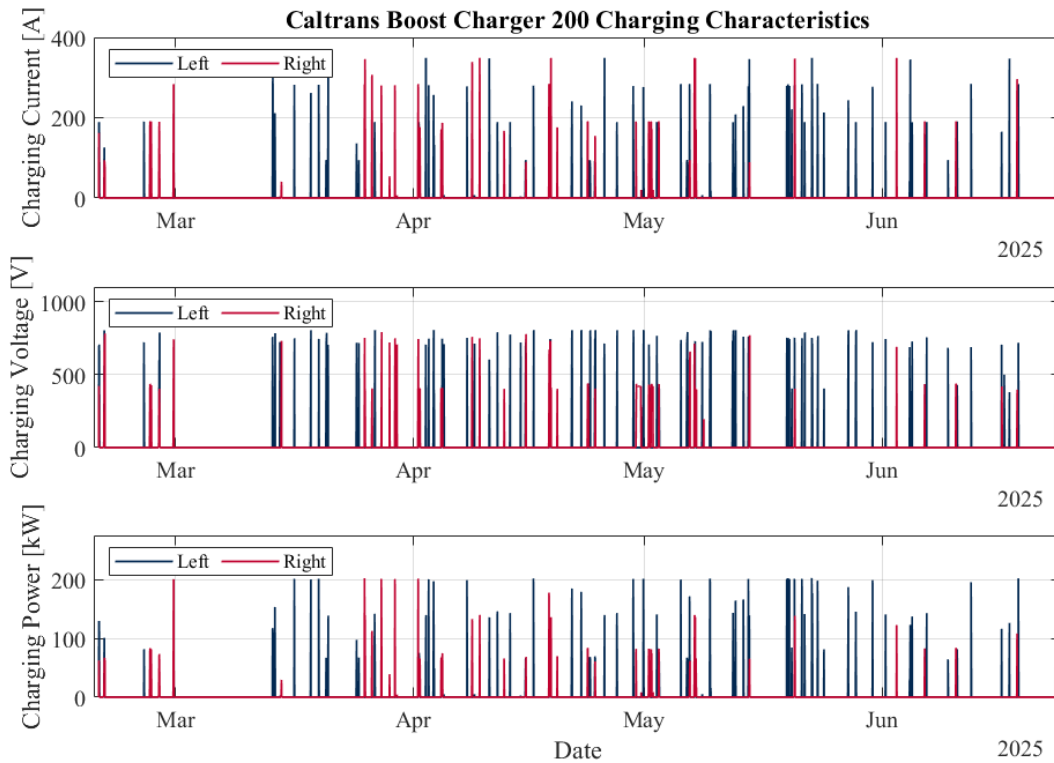


**Figure 5.32: Error codes during operation of the FreeWire Boost Charger 200 installed on UC Davis campus**

## Caltrans FreeWire Boost Charger 200 Evaluation

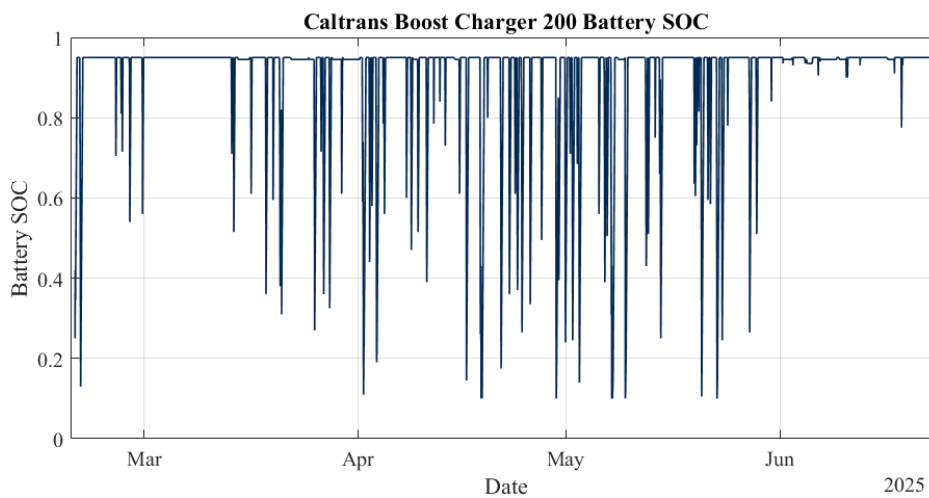
In late February 2025, the FreeWire Boost Charger 200 unit that was purchased for this project was installed at the Caltrans facility in Bloomington, CA. This private charger has two CCS1 type charging ports. Usage data were provided by FreeWire for February 2025 to June 2025, and the report shows the same data and resolution patterns as the previous analyses.

Figure 5.33 shows the charging current, voltage, and power for the 4.5-month dataset showing the brief periods during the set up when it wasn't operating and the frequent daily usage. The figure shows the charging events provided from the left and right charging port, both of which are CCS1 connectors.



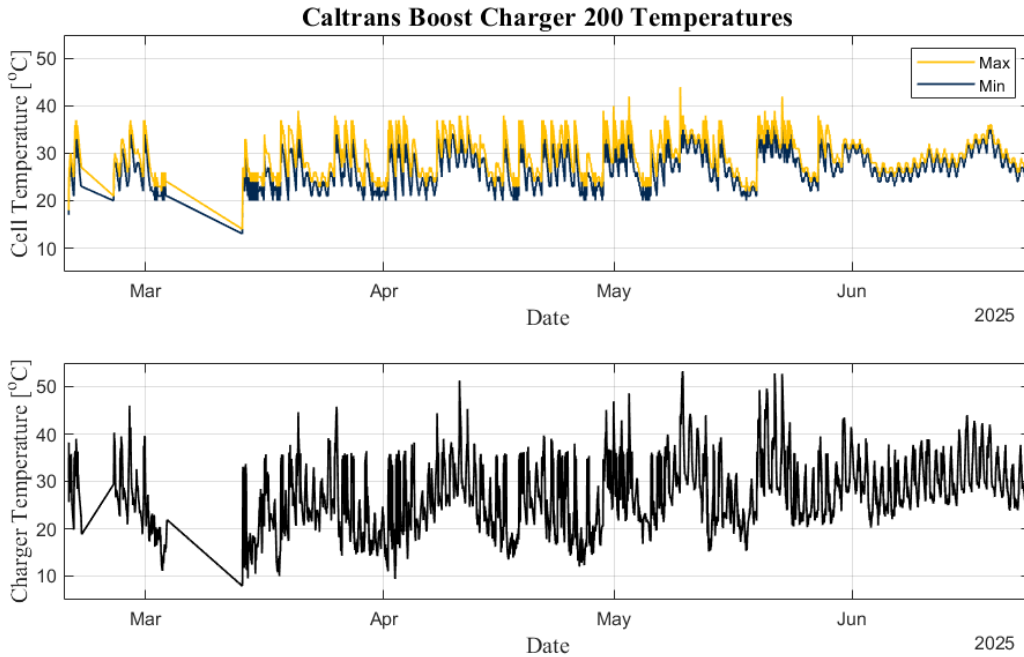
**Figure 5.33: Charging current, voltage, and power of both CCS1 ports of the FreeWire Boost Charger 200 installed at Caltrans**

Figure 5.34 shows the SOC of the Boost Charger 200 integrated battery. The low levels of usage mean that the battery is often at a high SOC value, but longer charging sessions bring the SOC down to close to 10%.



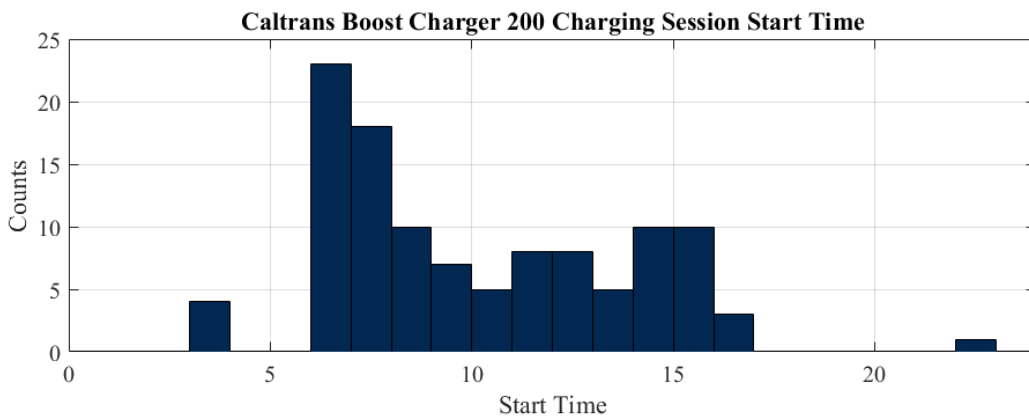
**Figure 5.34: SOC of the FreeWire Boost Charger 200 installed at Caltrans**

Figure 5.35 shows the minimum and maximum battery cell temperatures as well as the temperature of the charger itself. The temperatures vary daily and are impacted by the outside ambient temperature much more than any heating from charging.



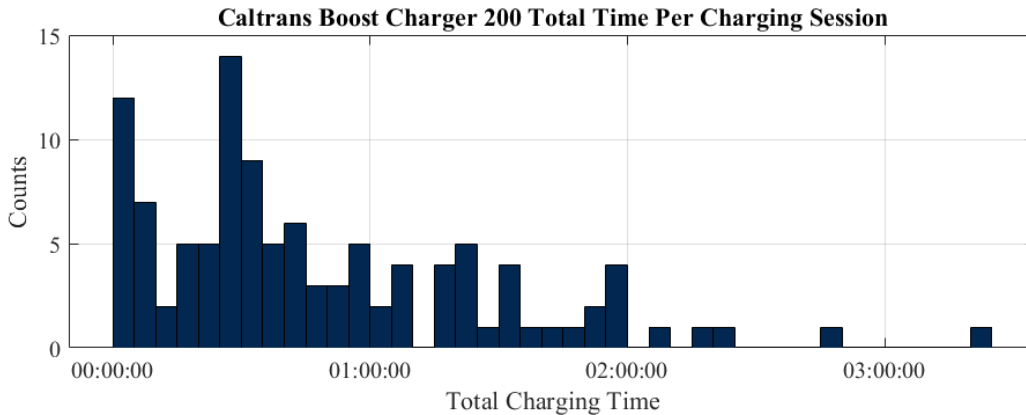
**Figure 5.35: The maximum and minimum cell temperatures and the charger temperature of the FreeWire Boost Charger 200 installed at Caltrans.**

Figure 5.36 shows the times when charging sessions are initiated. Charging sessions often occur during work hours, but there are a few early morning sessions and one late at night.



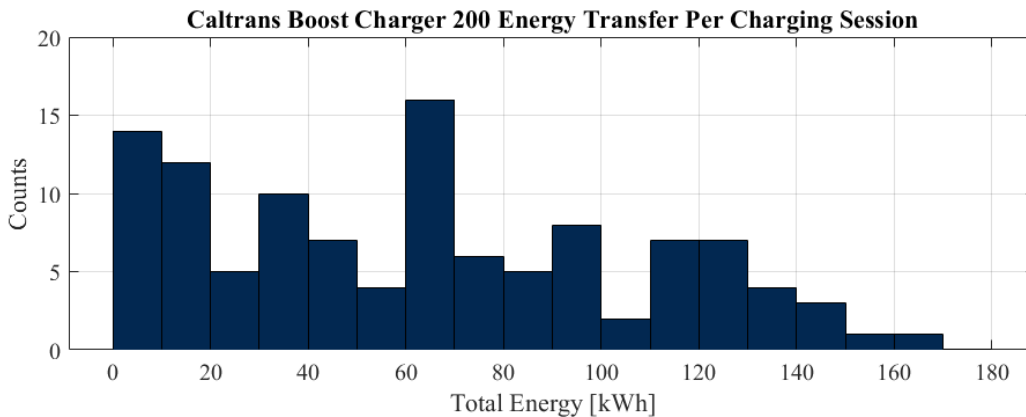
**Figure 5.36: Charging start times of the FreeWire Boost Charger 200 installed at Caltrans**

Figure 5.37 describes the typical length of time for each charging session at the Caltrans FreeWire Boost Charger 200; 69.1% of the charging sessions last less than one hour.



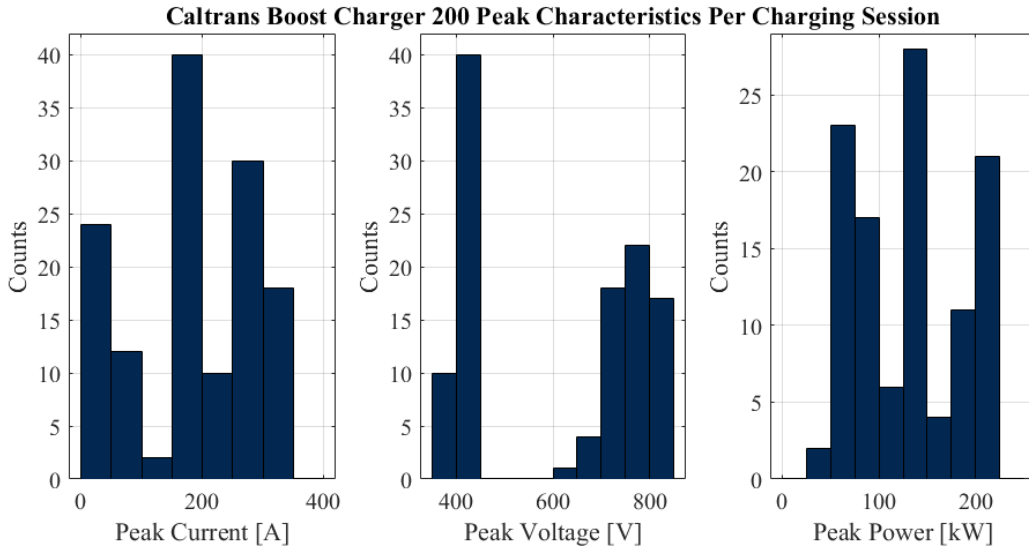
**Figure 5.37: Total charging session times of the FreeWire Boost Charger 200 installed at Caltrans**

Figure 5.38 shows the total energy transferred during each charging session, which is 100 kWh or less in 79.1% of charging sessions.



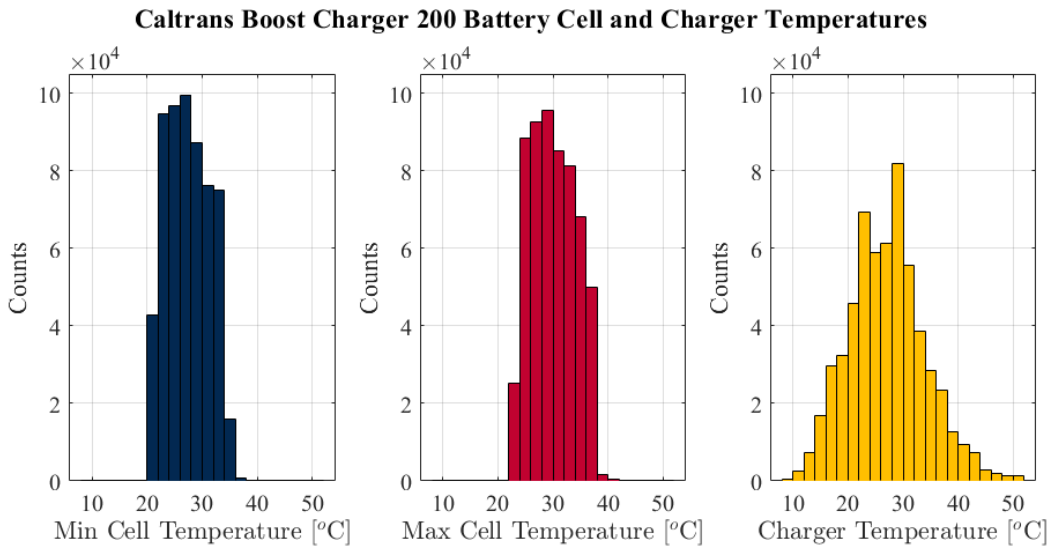
**Figure 5.38: Total energy transferred per charging session of the FreeWire Boost Charger 200 installed at Caltrans**

Figure 5.39 shows the peak current, voltage, and power of each charging session. The Boost Charger 200 will provide up to 200 kW of power to charge one vehicle, but if two vehicles are charging simultaneously, they can only receive 100 kW each.



**Figure 5.39: The peak current, voltage, and power of each charging session of the FreeWire Boost Charger 200 installed at Caltrans**

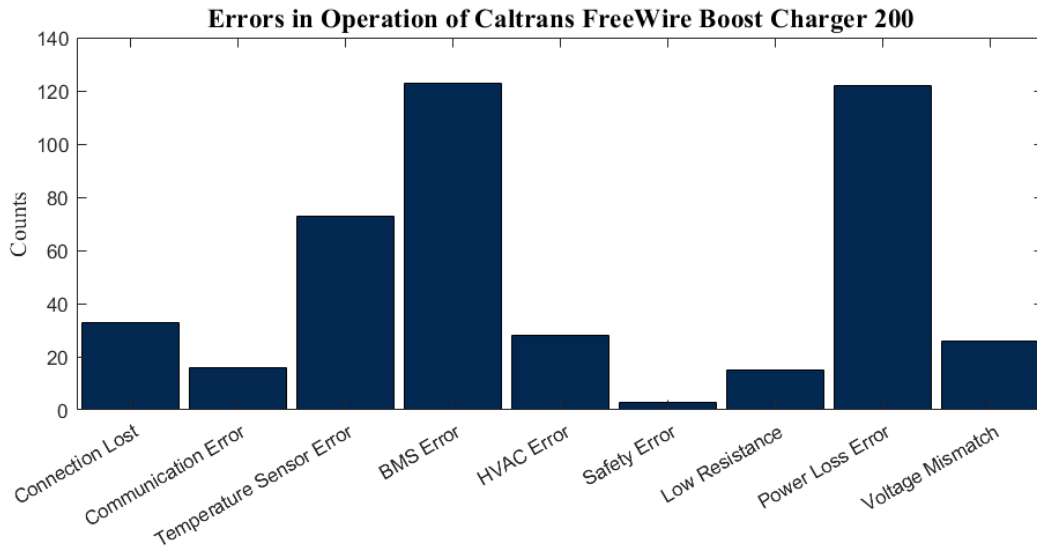
The FreeWire Boost Charger 200 temperature statistics can be seen in Figure 5.40. Overall, the minimum and maximum cell temperatures tend to be steady at between 20°C to 38°C and 22°C to 42°C respectively, but the temperature of the whole charger varies significantly more.



**Figure 5.40: The maximum and minimum cell temperatures and the charger temperature of the FreeWire Boost Charger 200 installed at Caltrans**

The error messages associated with the operation of the Caltrans FreeWire unit are shown in Figure 5.41. Most errors are from the temperature sensors, the BMS, or power loss errors. Other significant errors relate to the connection,

communication, HVAC, safety, low resistance, and voltage mismatch; although, most of these errors resolve themselves and do not result in a lack of charging ability.



**Figure 5.41: Error codes during operation of the FreeWire Boost Charger 200 installed at Caltrans**

The specific vehicles that were charged at this facility were recorded. The charging session of a Chevrolet Silverado EV on May 27, 2025 is depicted in Figure 5.42. The other charging sessions are found in Appendix D.

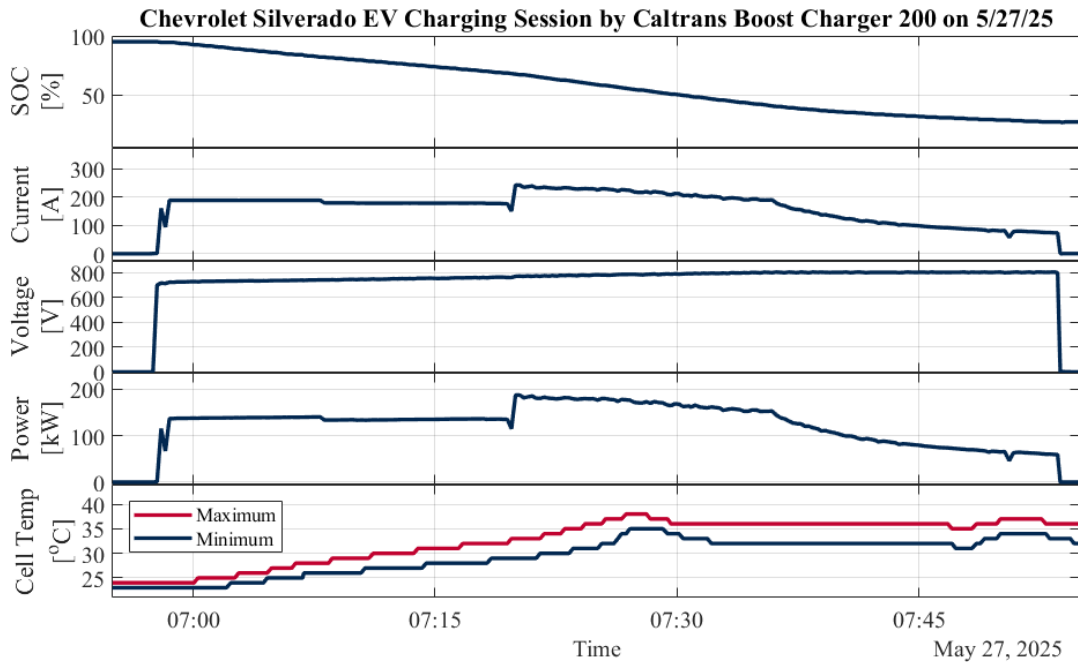


Figure 5.42: FreeWire Boost Charger 200 installed at Caltrans. SOC, current, voltage, power, and minimum and maximum cell temperatures while charging Chevrolet Silverado EV.



Figure 5.43: FreeWire Boost Charger 200 replacement unit commissioning process at SpeedCharge HQ: operational interface (left), unit in testing facility (middle), technical specifications (right)

In addition to the Chevrolet Silverado EV, which is the main vehicle being charged by the Boost Charger 200 at the Caltrans site, the electric sweeper Global M4 HSD was successfully tested with the charger installed at UC Davis. Overall, no compatibility issue with EVs has been reported for the Boost Charger 200.

The original FreeWire Boost Charger 200 unit experienced battery-related issues that necessitated a complete unit replacement. As confirmed in correspondence with SpeedCharge Services, the integrated battery system design prevents isolated battery replacement, requiring removal of the entire charger for installation of a new unit. The replacement Boost Charger 200 underwent comprehensive testing and commissioning at SpeedCharge's headquarters (HQ) facility in Newark, CA before delivery to Bloomington, CA. The commissioning process included extensive validation testing as documented in Appendix E, covering safety requirements, system components, and operational validation. Figure 5.43 shows the replacement unit during successful testing at SpeedCharge HQ, displaying operational parameters and confirming proper functionality before installation.

## **FreeWire Boost Charger 200 Battery Capacity Degradation from Long-term Usage**

The FreeWire Boost Charger 200 DCFC is integrated with a 160 kWh lithium nickel cobalt manganese oxide (NMC) battery. Lithium-ion batteries show promise for stationary energy storage applications since they have high energy density, high efficiency, and a low self-discharge rate; however, some barriers still exist in terms of high cost and limited battery lifetime.

Lithium-ion batteries work by transferring lithium ions between a positive electrode (cathode) and a negative electrode (anode) as a charging or discharging current passes outside of the battery. The total capacity of the battery describes the total energy storage capability, which relates to the amount of lithium ions that can be transferred from cathode to anode (during charging) and from anode to cathode (during discharging). As the battery degrades, it can store less and less energy; thus, the primary metric to describe the aging of lithium-ion batteries is battery capacity fade.

Capacity aging mechanisms relate to the loss of active lithium ions primarily through solid electrolyte interphase (SEI) formation. The SEI is a layer of lithium compounds, such as lithium carbonate and lithium oxide, that forms on the surface of the electrodes at the first cycling of the battery. This first thin layer is vital for battery operation, but further growth of the SEI consumes active lithium ions, which depletes the capacity of the battery. Wang et al. [8] observed different aging mechanisms at low and high temperatures. At low temperatures

the graphite node has slow kinetics, so forcing high currents leads to surface cracks and thus more SEI formation. On the other hand, high temperatures accelerate the chemical side reactions that lead to SEI growth.

The battery integrated in the FreeWire Boost Charger 200 is equivalent to four Nissan Leaf batteries, which have a series-parallel configuration. Therefore, the aging for this unit is estimated with a model validated for a Nissan Leaf battery [9].

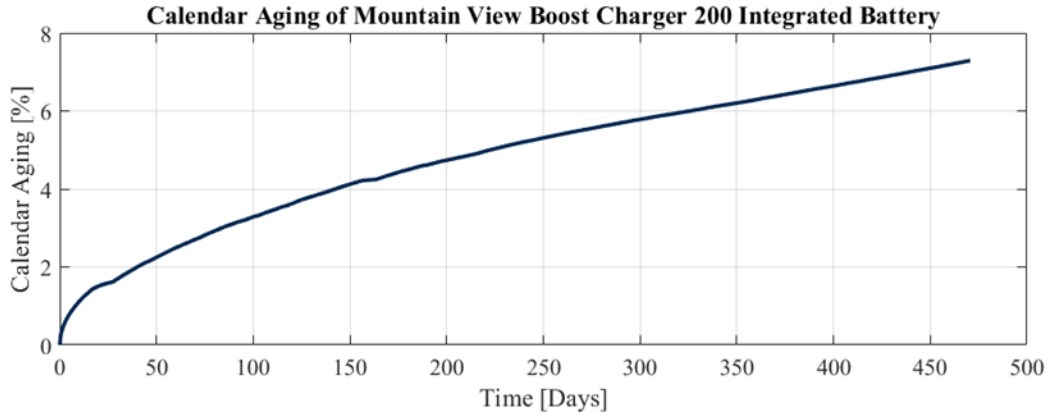
Semi-empirical models have been developed to describe the capacity degradation in two forms: calendar aging, which describes the capacity loss that occurs throughout time, and cyclic aging, which is directly from the cycling applied to the battery.

Marinelli et al. [9] describe the model for calendar aging as:

$$q_{cal} = 1/\Delta t \int \left( f \cdot e^{((-E_a)/RT)} \cdot \sqrt{t} - f \cdot e^{((-E_a)/RT)} \cdot \sqrt{(t - \Delta t)} \right) dt \quad (1)$$

where  $f$ , the pre-exponential factor, is dependent on the SOC of the battery and is higher at high SOC values. Storing a battery at high temperatures and high SOC values will negatively impact its useful lifetime.  $E_a$  is the activation energy, and  $R$  is the gas constant. The SEI growth is thermally activated, which is described with the Arrhenius dependence on temperature,  $T$ , and it is a diffusion limited process, so it has a square root of time,  $t$ , relationship.

Since the data provided for the Mountain View FreeWire Boost Charger 200 covers the longest duration, we can apply this model to the data for 470 days of operation. The data describes the maximum and minimum cell temperatures, so if we consider the entire battery to be at the mean temperature, the calendar aging of the Mountain View Boost Charger 200's battery can be estimated as shown in Figure 5.44.



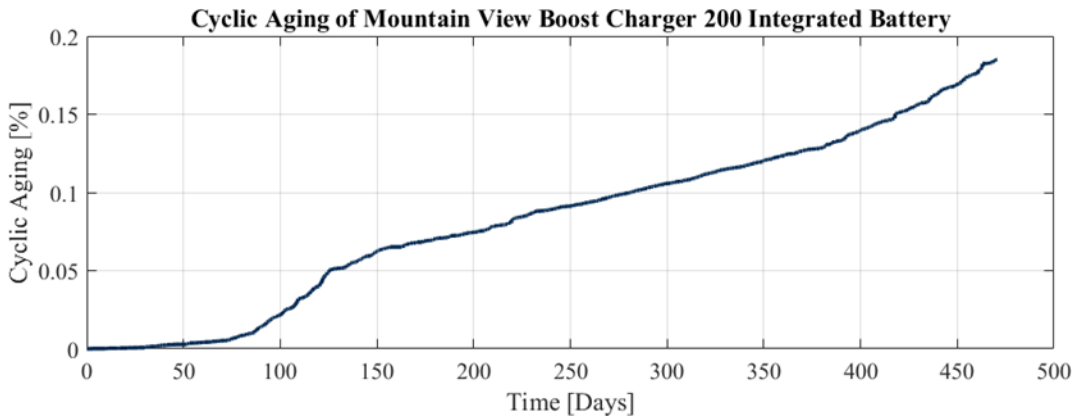
**Figure 5.44: Modeled calendar aging of the Mountain View FreeWire Boost Charger 200 from 470 days of historical data**

The model for cyclic aging as described by Marinelli et al. [2] is:

$$q_{cyc} = \int (aT^2 + bT + c) \cdot e^{((dT+e)I/Q)} \cdot I/(3600Q) dt \quad (2)$$

which is dependent on temperature,  $T$ , and the discharge current applied. The constants  $a$ ,  $b$ ,  $c$ ,  $d$ , and  $e$  describe the influence of temperature on the pre-exponential and exponential factors.  $Q$  is the battery capacity, and  $I$  is the discharge current applied to the battery.

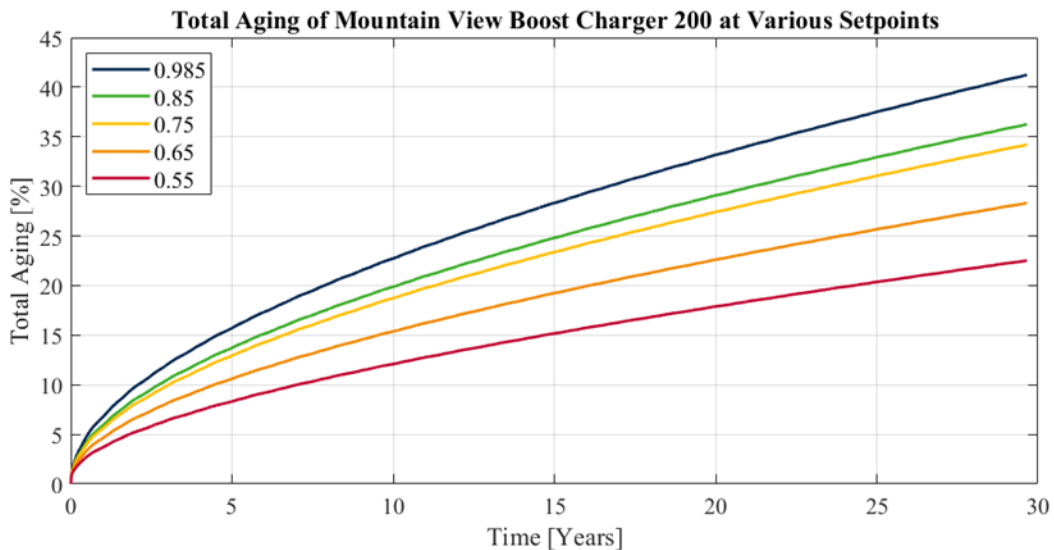
The cyclic aging model can be similarly applied to the usage data as shown in Figure 5.45 for the Mountain View Boost Charger 200's battery.



**Figure 5.45: Modeled cyclic aging of the Mountain View FreeWire Boost Charger 200 from 470 days of historical data**

As is evident, the degree of calendar aging is significantly greater than that of cyclic aging, which is consistent with experimental results for capacity degradation of NMC batteries [9]. This is a result of the SOC "setpoint", or the

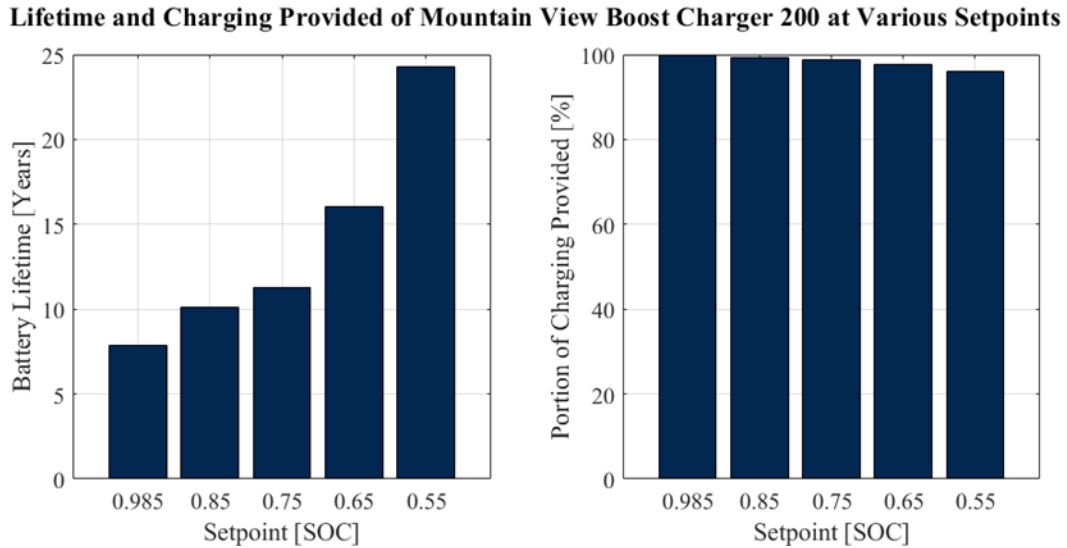
SOC value to which that the system will charge itself. So, when a vehicle is charged and depletes the boost charger’s battery, it will recharge itself up to the setpoint. Since the charger is only in use for a small fraction of the time, much of the time it is at this high setpoint of 0.985. Storing a NMC battery at a high SOC significantly increases calendar degradation. Therefore, if the SOC setpoint was to be lowered, the calendar aging could be significantly reduced; however, this poses a risk for the Boost Charger to be unable to complete some charging sessions. Assuming the same pattern of usage, the historical data have been extrapolated for approximately 30 years of operation at various setpoints shown in Figure 5.46 to show the total aging at each one. While keeping the battery SOC setpoint at 0.985 results in over 30% capacity degradation after 20 years of operation, reducing this setpoint to 0.55 improves this degradation to less than 20% over 20 years.



**Figure 5.46: Modeled total aging of the Mountain View FreeWire Boost Charger 200 extended to 30 years. Data are shown for different setpoints that describe the SOC which the unit will recharge up to after it has been depleted from a vehicle charging event.**

While there is no standard for stationary purposes, vehicle batteries’ end-of-life is considered when the capacity has degraded by 20%. Assuming 20% capacity loss as the end-of-life, the total lifetime of the Mountain View Boost Charger 200’s battery is approximated for each of the setpoints considered in Figure 5.45. At the current operating SOC setpoint of 0.985, the battery lifetime is approximately 8 years, but if the setpoint is changed to 0.55, the lifetime can be increased to approximately 24 years.

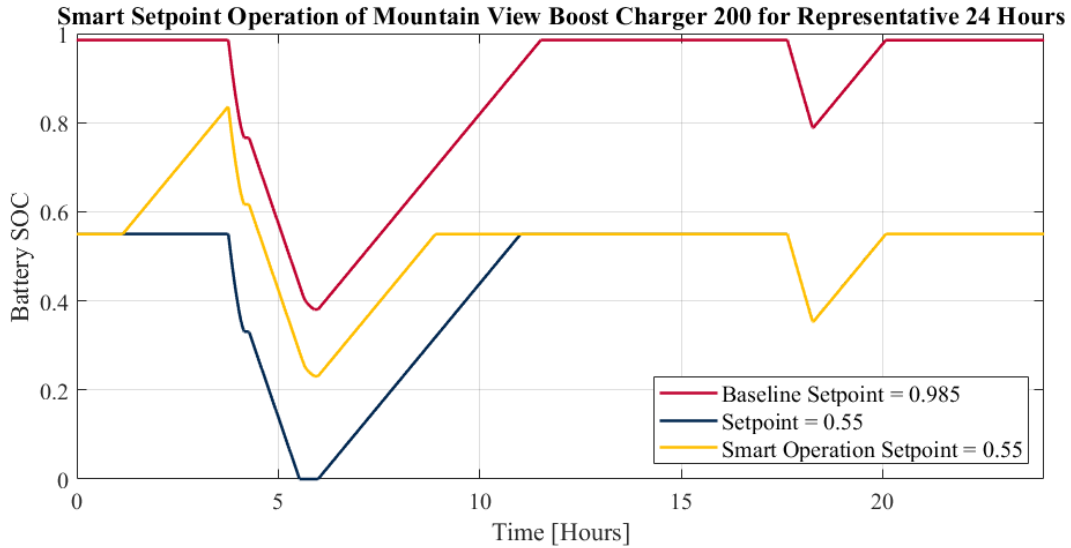
If the SOC setpoint is lowered, in each of the cases discussed above, there are some charging sessions that could not be covered, so Figure 5.47 shows the percentage of charging current provided in relation to the base setpoint. If the SOC setpoint is changed to 0.55, the percentage of charging that can still be provided is 96%.



**Figure 5.47: Battery expected lifetime assuming end-of-life at 20% capacity loss (left) and percentage of charging provided at various SOC setpoints (right) by the Mountain View FreeWire Boost Charger 200**

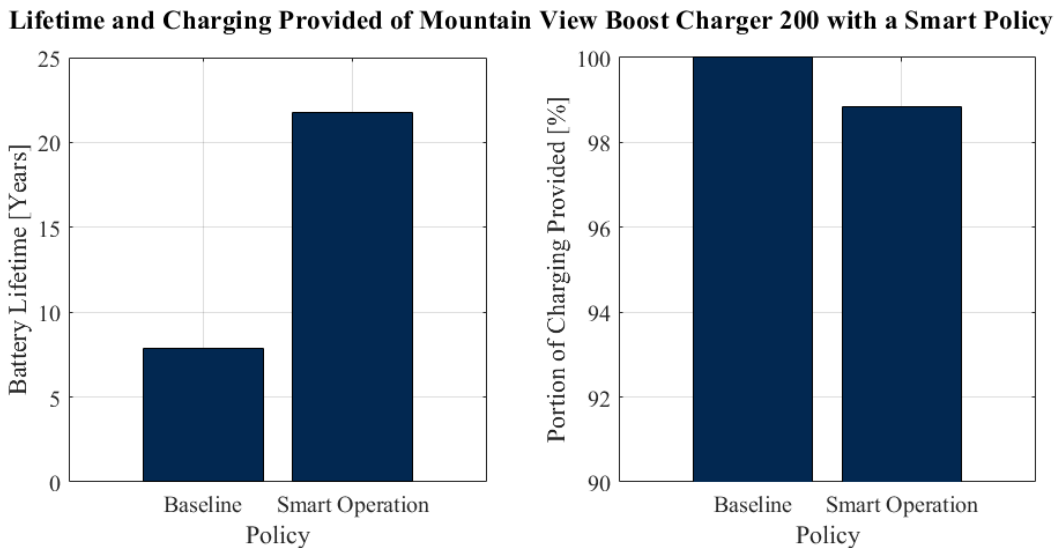
## *Smart Operation of FreeWire Boost Charger 200*

To preserve the life of the battery and increase the percentage of charging which can be provided, a “smart charging” policy can be adopted assuming some future knowledge of an upcoming charging event. If we assume the charging system knows 3 hours ahead of time that there will be a significantly large charging event, the battery can be pre-charged to have more available energy. This smart setpoint policy can be seen as a representative 24 hours in Figure 5.48 compared to the data baseline with a setpoint of 0.985 and the simple operation at a setpoint of 0.55.



**Figure 5.48: Battery SOC for smart setpoint operation of the Mountain View FreeWire Boost Charger 200**

This smarter operation may lead to some increased aging compared to keeping the SOC set point low at all times; however, this strategy will allow for more charging sessions to be completed. Figure 5.49 shows the battery lifetime of the smart operation policy compared to the baseline operation from the historical data. The smart operation allows the lifetime to be increased to 22 years and is able to provide 99% of the requested charging.



**Figure 5.49: Battery expected lifetime assuming end-of-life at 20% capacity loss (left) and percentage of charging provided (right) based on the baseline and smart SOC policy used by the Mountain View FreeWire Boost Charger 200**

The following conclusions can be made about the degradation and lifetime of the Mountain View Boost Charger 200's battery:

- The primary mechanism for aging of the Boost 200 battery is calendar aging, which is the degradation that occurs overtime regardless of usage.
- Calendar aging is mostly influenced by the SOC of the battery. The current control strategy results in expedited aging since it keeps the battery at almost full charge when not in operation.
- Changing the charging policy to have a lower SOC setpoint that the system will charge up to after the battery is depleted from a vehicle charging event can increase the lifetime of the battery by 15 years, while only being unable to provide 4% of the vehicle charging events, according to the battery usage profile for the Mountain View installation.
- Furthermore, implementing a smart charging policy that can predict large charging sessions and pre-charges the battery can provide 99% of the charging, while increasing the life of the system to around 22 years compared to only 8 years for the baseline policy.
- Overall, battery degradation should be taken into account when programming the DCFC unit and planning the usage of the charger. If the timing of charging events is known in advance, a smart policy can be highly effective in prolonging the lifetime of the system and decreasing the total cost of ownership.

## Reported Specifications

The AHMCT team evaluated the FreeWire Boost Charger 200 through the analysis of the historical data provided for the project unit and additional three units in California. Table 5.1 describes the reported specifications for the FreeWire Boost Charger 200 compared to the maximum values present in the historical usage data.

**Table 5.1: Charging specifications reported from FreeWire compared to historical usage data**

Specifications	Reported values from FreeWire	Values from Usage Data
<b>CCS1 Max Output Power</b>	200 kW	200.8 kW
<b>CHAdeMO Max Output Power</b>	100 kW	76.1 kW

Specifications	Reported values from FreeWire	Values from Usage Data
<b>CCS1 Max Output Current</b>	300 A	351.5 A
<b>CHAdeMO Max Output Current</b>	200 A	200.0 A
<b>Minimum Operating Temperature</b>	-20 °C	11.8 °C
<b>Maximum Operating Temperature</b>	55 °C	59.3 °C
<b>Battery Capacity</b>	160 kWh	154.7 kWh

The CCS1 connector reaches the manufacturer specified maximum power of 200 kW; however, the maximum power experienced by the CHAdeMO port was 76.1 kW. Since the charging power is determined by the EV, this number does not indicate the maximum power that the FreeWire Boost Charger 200 can provide through this port. The maximum current for both charging connector types meets the manufacturer specifications, and for the CCS1 port, it exceeds the manufacturer claims. This may be due to high current requirements for the charging vehicle, and the current at the battery would be lower because the power is converted by the DCDC converter. Due to the temperate climate at all four FreeWire Boost Charger 200 locations, the minimum temperature experienced was only 11.8 °C; however, the maximum temperature exceeded the operating limit of 55 °C. The true battery capacity is calculated by determining the throughput of a charging session and comparing that to the change in the Boost Charger 200's battery SOC.

# Chapter 6:

## Conclusions and Future Research

### Conclusions and Recommendations

This research evaluated two mobile and semi-permanent EV charging solutions, EVESCO EVES-6060-NA and FreeWire Boost Charger 200, to determine their suitability for Caltrans' EV fleet. The study assessed each system's delivery, operational capabilities, charging performance, and vendor support.

### *Research Fulfillment and Achievement*

The research successfully evaluated both mobile charging systems in performance and potential for implementation in Caltrans' operations. However, FreeWire Boost Charger 200 testing was limited by permitting delays, necessitating the use of historical data from three existing units. Despite this adaptation, the analysis provided valuable insights into performance patterns and battery degradation over time.

### *Deviations from Planned Research*

The research encountered several unexpected challenges:

- **Data Collection Limitations:** The EVESCO unit lacked both cloud-based and onboard data collection capabilities, contrary to vendor claims, requiring manual data collection methods through screen recording.
- **Permitting and Installation Delays:** The FreeWire Boost Charger 200 unit, despite being labeled "semi-permanent", required substantial foundation work and fire marshal permits, delaying installation until February 2025.
- **Compatibility Issues:** The EVESCO unit's unreliable compatibility with public DCFC charging stations necessitated more extensive testing than initially planned.

# Summary of Key Findings

## *EVESCO EVES-6060-NA Key Findings*

1. **Vehicle Compatibility:** The EVESCO unit is compatible with all tested Caltrans EVs; although, Tesla vehicles presented occasional connection difficulties with the NACS port and often required a CCS1-to-NACS adapter.
2. **Charging Performance:** Testing confirmed a maximum current of 60 A as specified in the manual, limiting power delivery capabilities to 54 kW.
3. **Battery Capacity Considerations:** The 60-kWh battery allows for a full charge on only one light-duty vehicle before requiring a recharge. (Specifically, for EVs from Caltrans' EV list as described in Table 4.2.)
4. **Infrastructure Compatibility:** The unit was able to initiate charging sessions with only 7 of 21 public DCFCs tested. The unit worked reliably with 3-phase 480 V AC power.
5. **Cold Weather Performance:** The unit was functional in cold conditions but displayed battery warning messages during prolonged exposure to cold.
6. **Data Collection:** The unit does not have integrated data collection systems, preventing automated performance monitoring.
7. **Delivery Timeline:** There were significant delays in receiving the unit from the manufacturer.
8. **Portability:** The unit is portable but requires a dedicated trailer for transportation.
9. **Connectivity Requirements:** The unit requires internet connection to charge from DCFC stations.

## *FreeWire Boost Charger 200 Key Findings*

1. **Installation Requirements:** The FreeWire Boost Charger 200 requires a permanent foundation despite its "semi-permanent" designation.
2. **Infrastructure Compatibility:** The FreeWire Boost Charger 200 requires minimum of 3-phase 208 V AC power to charge its internal battery.
3. **Permitting:** Significant delays to installation and testing were caused by OSFM permit requirements.

4. **Installation Timeline:** Final installation occurred in February 2025, limiting direct testing opportunities.
5. **Data Analysis:** Research relied on historical data from three existing units.
6. **Vehicle Compatibility:** No compatibility issues were reported with UC Davis fleet vehicles or Caltrans-owned vehicles at the Magana Ortega site.
7. **Usage Patterns:** The public chargers averaged roughly 4 charging sessions per day for the CCS1 port, while the CHAdeMO port is only used 4 times a week. The private charger on UC Davis campus was used rarely, only averaging 8 charges a month.
8. **Battery Degradation:** The high SOC setpoint (98.5%) significantly accelerates battery degradation in the NMC battery chemistry used in the FreeWire Boost Charger 200.
9. **Warranty and Service Requirements:** Caltrans should consider purchasing extended warranty services for these systems as battery maintenance and repairs require specialized expertise that may not be readily available from third-party service providers.

## Value for Caltrans

This research provides valuable insights to Caltrans through:

- **Informed Purchasing Decisions:** Detailed comparison of mobile charging options aligned with operational needs.
- **Lifecycle Cost Understanding:** Identification of battery management strategies to reduce long-term costs.
- **Deployment Planning:** Compatibility testing with both vehicles and charging infrastructure to guide implementation.
- **Risk Identification:** Clear documentation of limitations in cold weather performance, connectivity requirements, and data collection capabilities.

## Recommendations

Based on our findings, the AHMCT team recommends the following:

## *For EVESCO EVES-6060-NA Deployment*

1. **Target Deployment:** Best suited for light-duty EV charging where 480 V AC power or public DCFCs with known compatibility are available.
2. **Transportation Planning:** Ensure dedicated trailers are available for unit mobility.
3. **Internet Connectivity:** Verify reliable internet access at deployment locations or implement a mobile solution, such as a wireless cellular modem.
4. **Cold Weather Protocols:** Understand effects of cold conditions on performance and functionality of the unit. Implement a method for mitigating these effects, such as pre-heating the unit for extended cold exposure.
5. **Manual Data Collection:** System operators must implement a regular monitoring protocol to track the unit's SOC and operational parameters. Schedule proactive charging based on usage patterns and available downtime to ensure continuous availability. The previous screen recording methodology is unsuitable for field deployment and should be replaced with a standardized logging procedure that captures critical performance metrics, charging cycles, and any operational anomalies.
6. **Procurement Planning:** Account for potential manufacturer delays in future purchases.

## *For FreeWire Boost Charger 200 Deployment*

7. **Installation Planning:** Budget for foundation work and construction.
8. **Permitting Process:** Start fire marshal permitting early to avoid delays.
9. **Battery Management:** Reduce the SOC setpoint from 98.5% to 55% to 70% to extend battery life. Use smart charging algorithms to extend the system life while supporting the operational needs of the heavy-duty vehicles with large energy demand.
10. **Strategic Placement:** Deploy units based on anticipated usage to prevent underutilization.
11. **Data Access:** Maintain appropriate subscriptions for continued access to system data.

## Lessons Learned

- **Recommended mobile DCFC specification:** To bridge the gap between the EVESCO EVES-6060-NA and the semi-permanent FreeWire Boost Charger 200, it is recommended to employ a mid-size, trailer-movable, battery-buffered DCFC with ~100–150 kWh and ~90–120 kW, equipped with dual CCS1/NACS leads, and 208–240 V 3-phase AC recharge to avoid 480 V upgrades and foundations. For communication standards, Caltrans should require DIN 70121 and ISO 15118 (-2/-20) support on the DC side, with CCS1/NACS outlets as the default (CHAdeMO optional for legacy compatibility), and OCPP (≥1.6-J; 2.0.1 preferred) for back-end management and vendor interoperability. These choices directly reflect field findings on EVESCO EVES-6060-NA limited DCFC compatibility and protocol/authentication issues, FreeWire Boost Charger 200 installation/permitting constraints, and observed port usage patterns.
- **Ensure compatibility:** Confirm that future mobile DCFCs support up-to-date communication protocols to ensure interoperability with both EVs and charging equipment.
- **Match system to application:** The EVESCO EVES-6060-NA is well-suited for light-duty and emergency-response applications, but consider systems with larger battery capacity for heavy-duty needs. The Boost Charger is suitable for both light- and heavy-duty use, though it lacks mobility.
- **Protect the investment:** Purchase a battery warranty for the system, if available.
- **Assess manufacturer viability:** Select manufacturers with demonstrated stability and long-term viability.
- **Require configurable battery SoC caps:** Chargers shall provide operator-configurable battery state-of-charge upper limits and charge/hold schedules (e.g., 50–70% SoC) accessible via local UI and remote management (OCPP).

## Future Research Directions

Several possible research directions emerged from this evaluation:

- **Extended Testing:** Conduct longer-term testing with more vehicles and scenarios, especially for the FreeWire Boost Charger 200 system.
- **Additional Technologies:** Evaluate mobile charging solutions from other manufacturers for comparison.
- **Battery Longevity Verification:** Monitor FreeWire Boost Charger 200 battery degradation to confirm the benefits of optimized SOC management.
- **Cold Weather Performance:** Further investigate EVESCO's performance during prolonged exposure to cold.
- **Charging Protocol Evolution:** Track compatibility between EVESCO and evolving public charging standards.

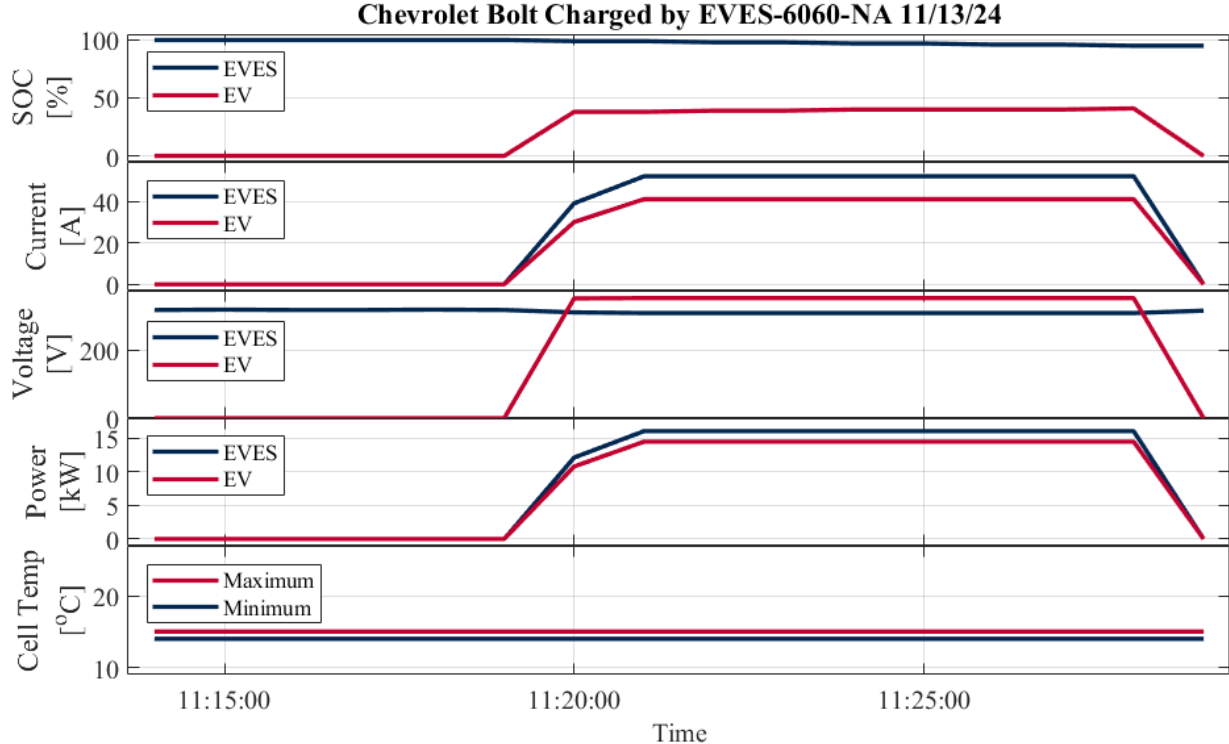
This evaluation shows that mobile charging solutions can effectively support Caltrans' transition to an EV fleet, but success requires careful planning and management to address the identified limitations. By implementing these recommendations, Caltrans can maximize the benefits of these technologies while minimizing operational risks.

# References

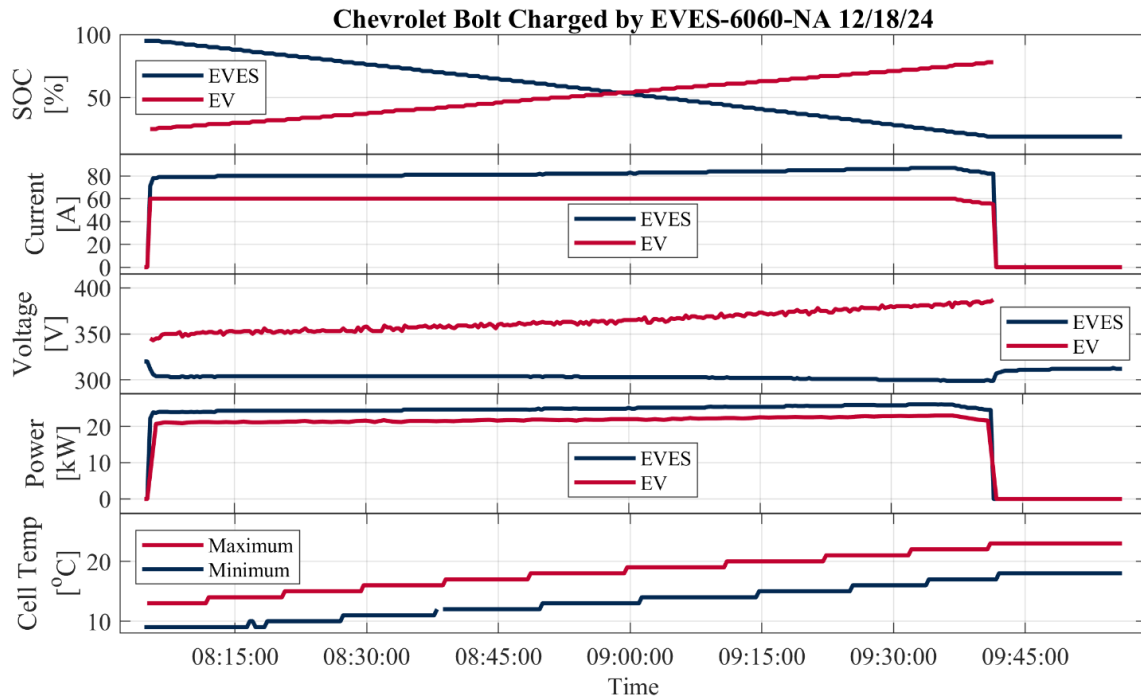
- [1] California Office of the Governor, "Executive Order N-79-20: Climate Change & Zero-Emission Vehicles," 2020. [Online]. Available: <https://www.gov.ca.gov/wp-content/uploads/2020/09/9.23.20-EO-N-79-20-Climate.pdf>
- [2] California Air Resources Board, "Advanced Clean Fleets Regulation (ACF)," 2023. [Online]. Available: <https://ww2.arb.ca.gov/our-work/programs/advanced-clean-fleets>
- [3] SIEPR, "Overcoming Roadblocks in California's Public EV Charging Infrastructure," Stanford University, 2023. [Online]. Available: <https://siepr.stanford.edu/publications/policy-brief/overcoming-roadblocks-californias-public-ev-charging-infrastructure>
- [4] California Energy Commission, "EV Charging Infrastructure Permitting," 2023. [Online]. Available: <https://www.energy.ca.gov/>
- [5] Caltrans, "Fleet Electrification Strategy Report," 2024. [Online]. Available: <https://dot.ca.gov/>
- [6] National Renewable Energy Laboratory (NREL), "Infrastructure Planning for Electric Fleets: Risks and Uncertainties," 2022. [Online]. Available: <https://www.nrel.gov/>
- [7] Airlink MP70 Series Hardware User Guide. 2016, source.sierrawireless.com/resources/airlink/hardware\_reference\_docs/airlink\_mp\_series\_userguide/#sthash.CFDogwl5.dpbs.
- [8] J. Wang et al., "Degradation of lithium-ion batteries employing graphite negatives and nickel–cobalt–manganese oxide+ spinel manganese oxide positives: Part 1, aging mechanisms and life estimation," *Journal of Power Sources*, vol. 269, pp. 937-948, 2014.
- [9] M. Marinelli, L. Calearo, and J. Engelhardt, "A Simplified Electric Vehicle Battery Degradation Model Validated with the Nissan LEAF e-plus 62-kWh," in *Proc. 6th Int. Electric Vehicle Technology Conf.*, 2023.

# Appendix A: Charging Performance Data and SOC Analysis for EVES-6060-NA Sessions

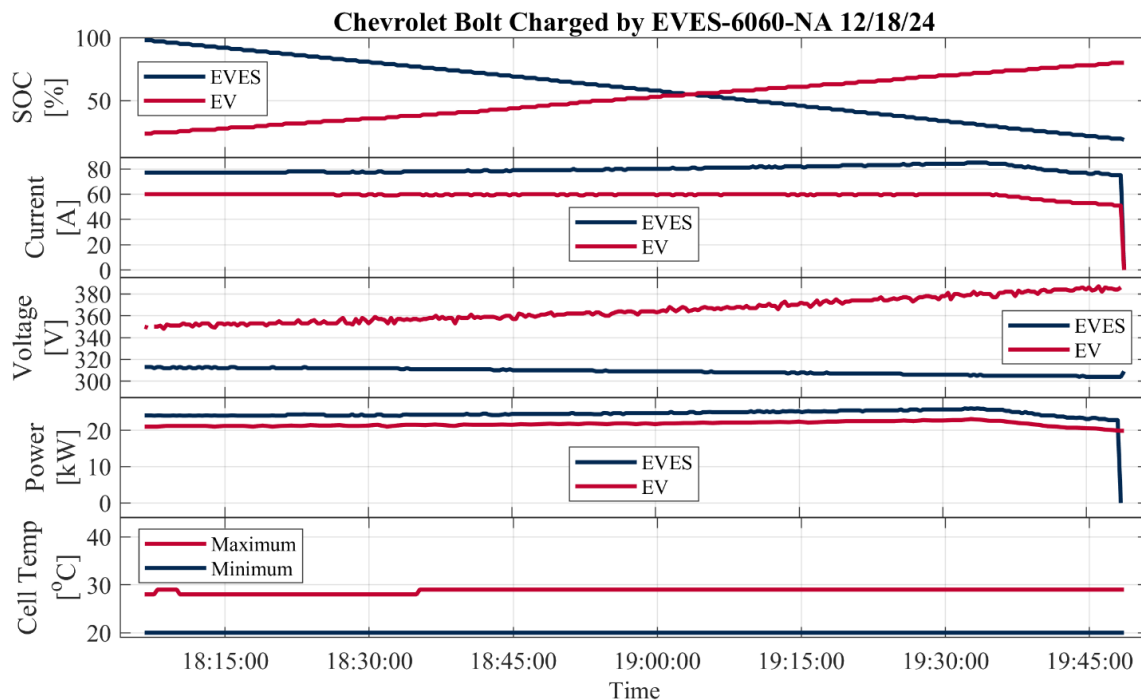
## Vehicle Charging



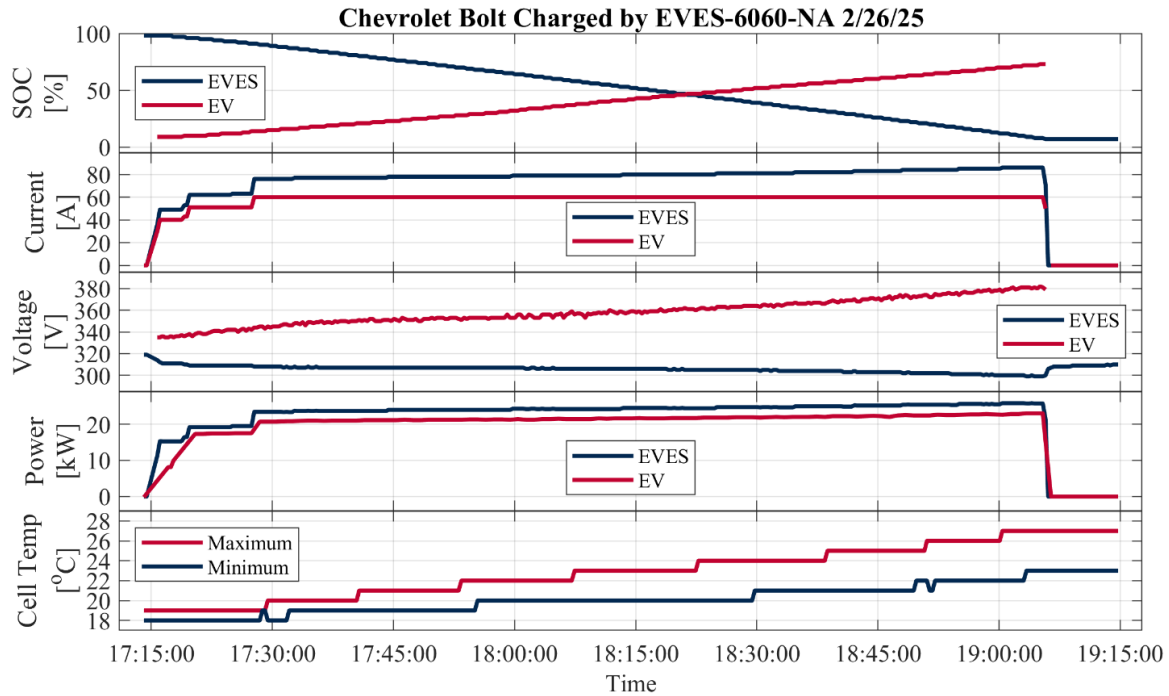
**Figure A.1: EVES and EV SOC, current, voltage, power, and minimum and maximum battery cell temperatures for charging session of Chevrolet Bolt by the EVES-6060-NA unit**



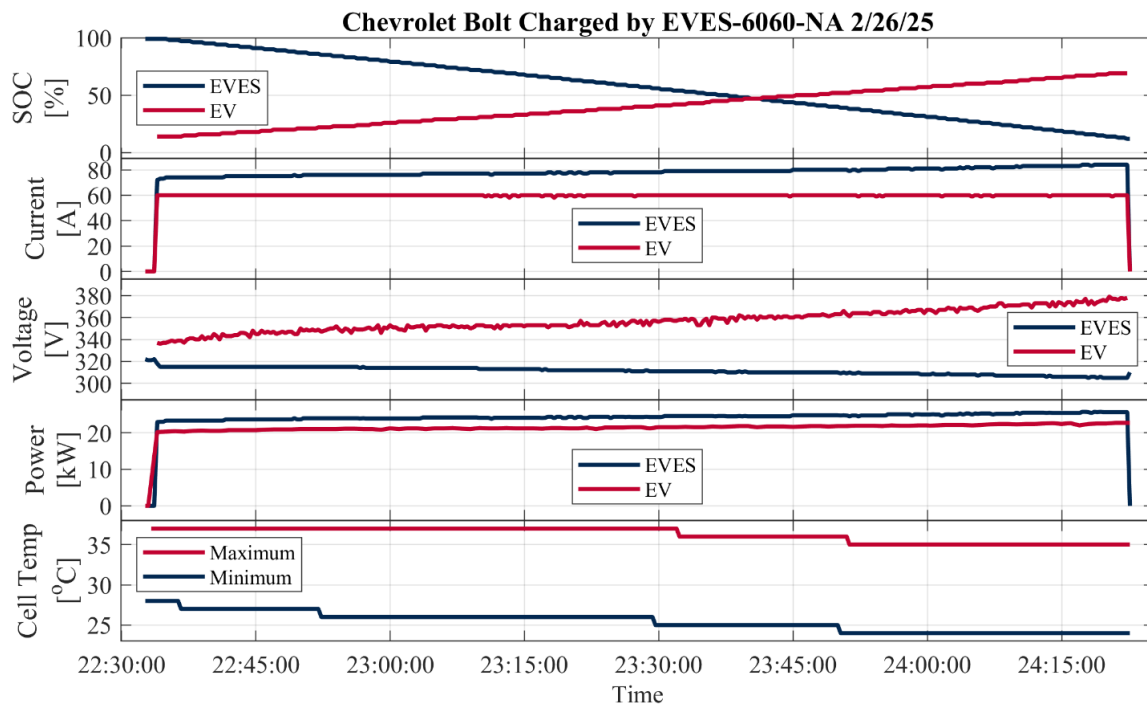
**Figure A.2: EVES and EV SOC, current, voltage, power, and minimum and maximum battery cell temperatures for charging session of Chevrolet Bolt by the EVES-6060-NA unit**



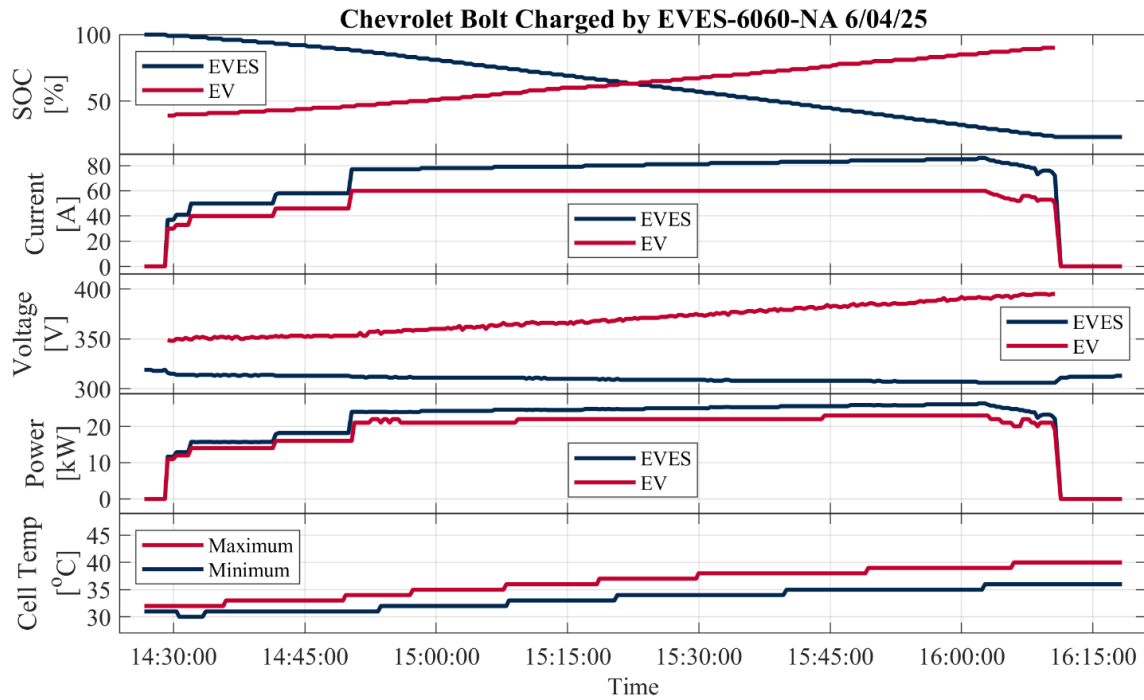
**Figure A.3: EVES and EV SOC, current, voltage, power, and minimum and maximum battery cell temperatures for charging session of Chevrolet Bolt by the EVES-6060-NA unit**



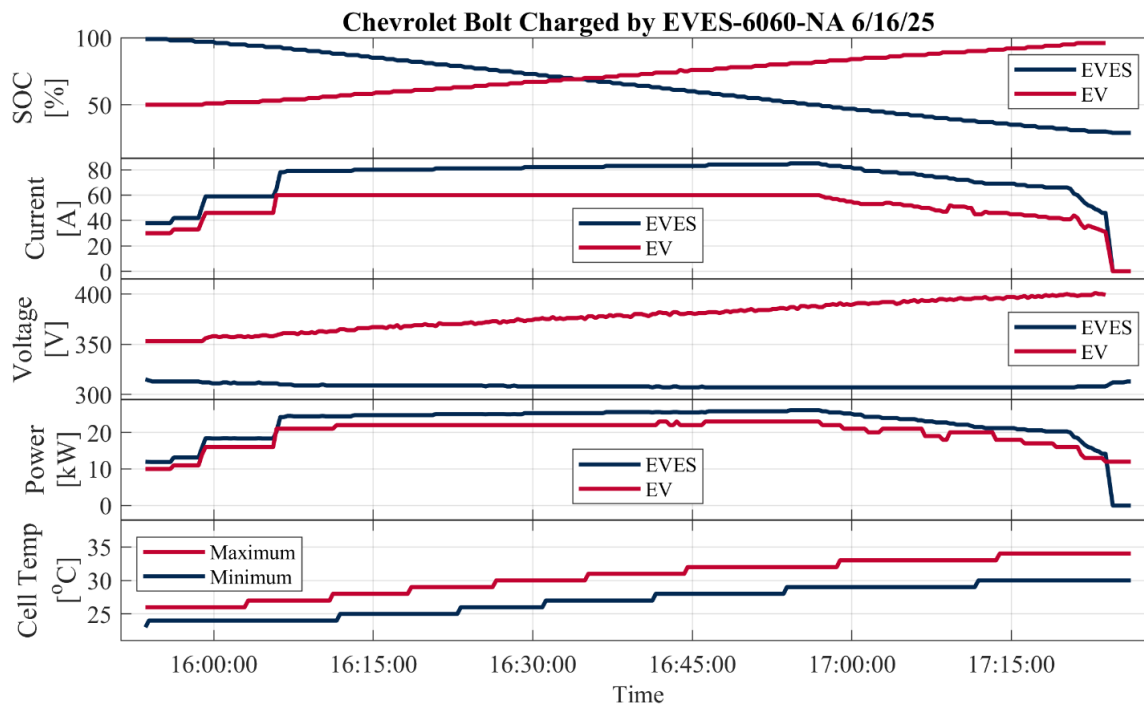
**Figure A.4: EVES and EV SOC, current, voltage, power, and minimum and maximum battery cell temperatures for charging session of Chevrolet Bolt by the EVES-6060-NA unit**



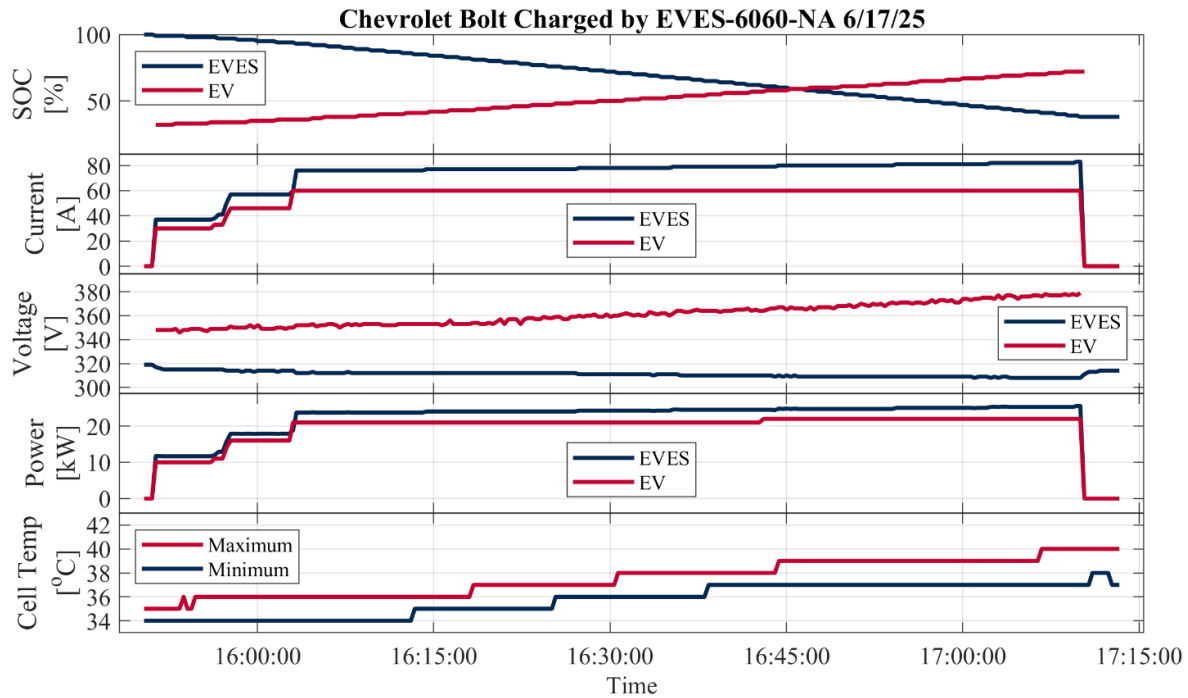
**Figure A.5: EVES and EV SOC, current, voltage, power, and minimum and maximum battery cell temperatures for charging session of Chevrolet Bolt by the EVES-6060-NA unit**



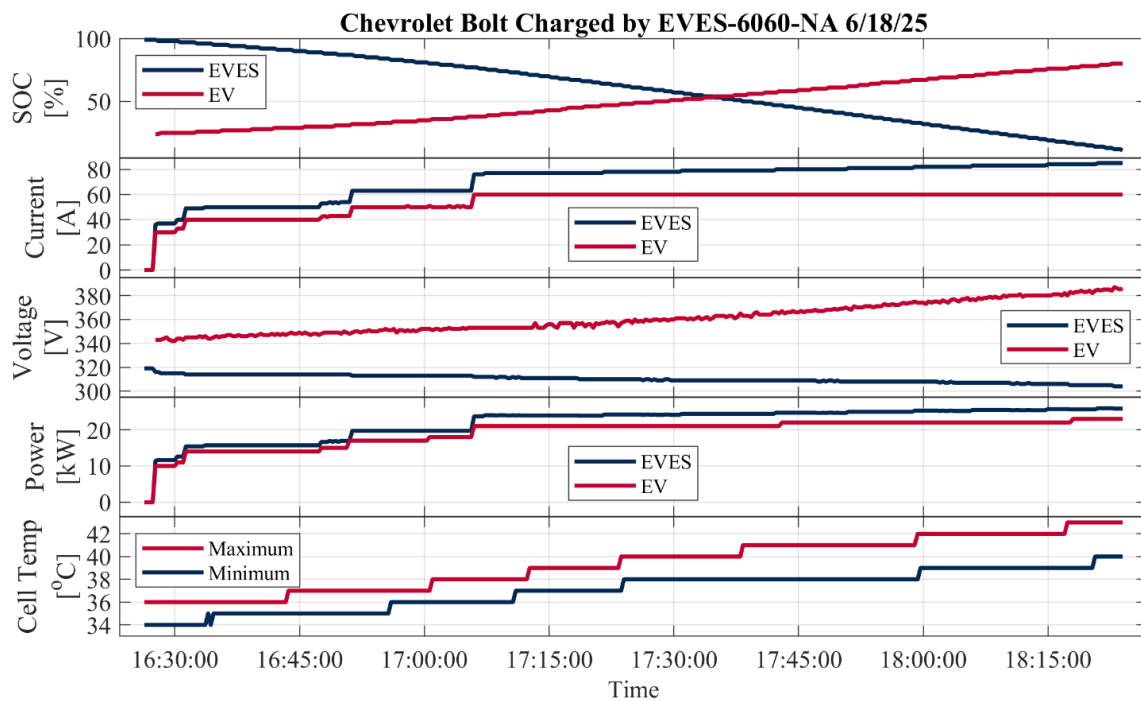
**Figure A.6: EVES and EV SOC, current, voltage, power, and minimum and maximum battery cell temperatures for charging session of Chevrolet Bolt by the EVES-6060-NA unit**



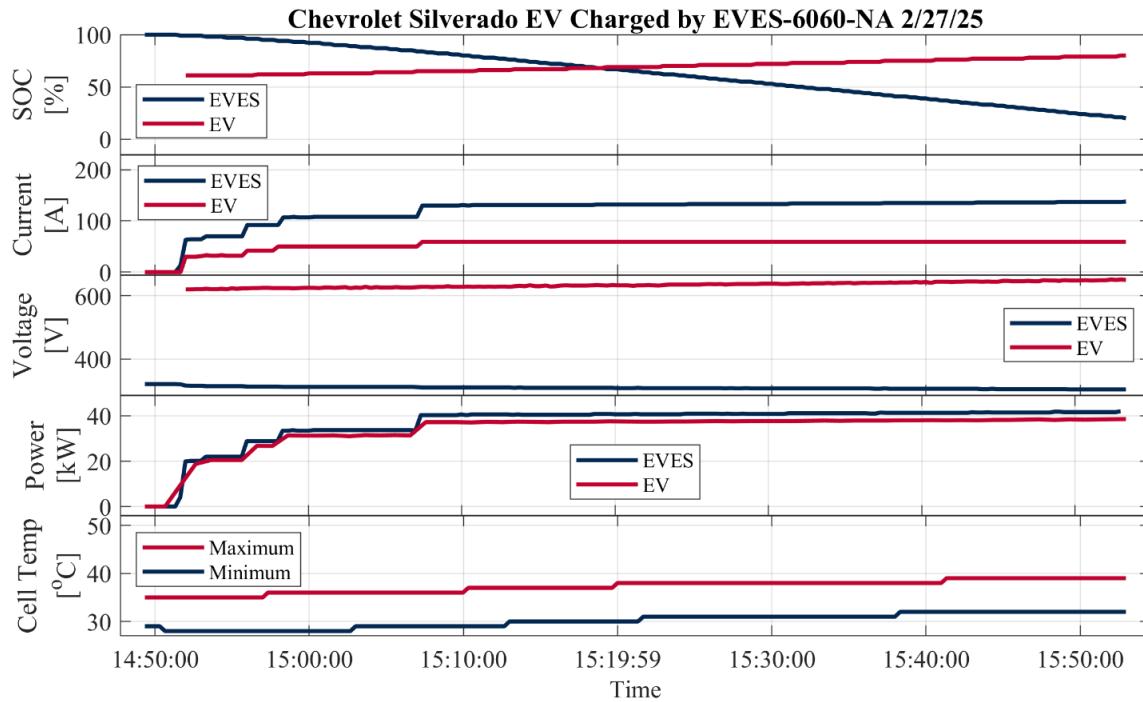
**Figure A.7: EVES and EV SOC, current, voltage, power, and minimum and maximum battery cell temperatures for charging session of Chevrolet Bolt by the EVES-6060-NA unit**



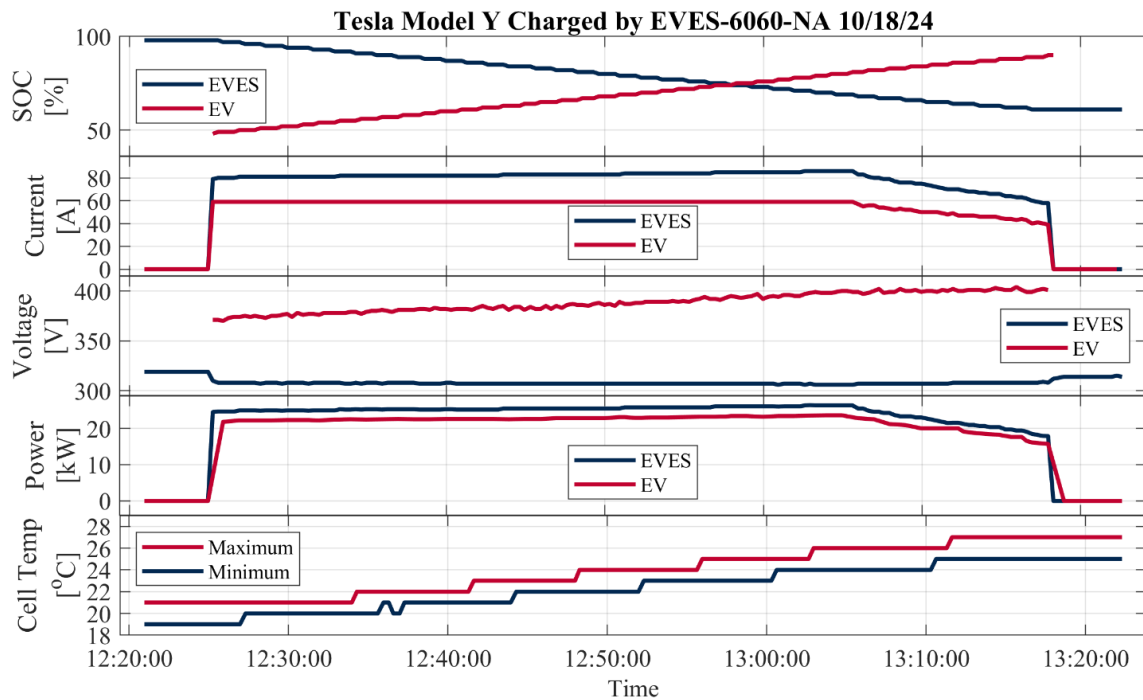
**Figure A.8: EVES and EV SOC, current, voltage, power, and minimum and maximum battery cell temperatures for charging session of Chevrolet Bolt by the EVES-6060-NA unit**



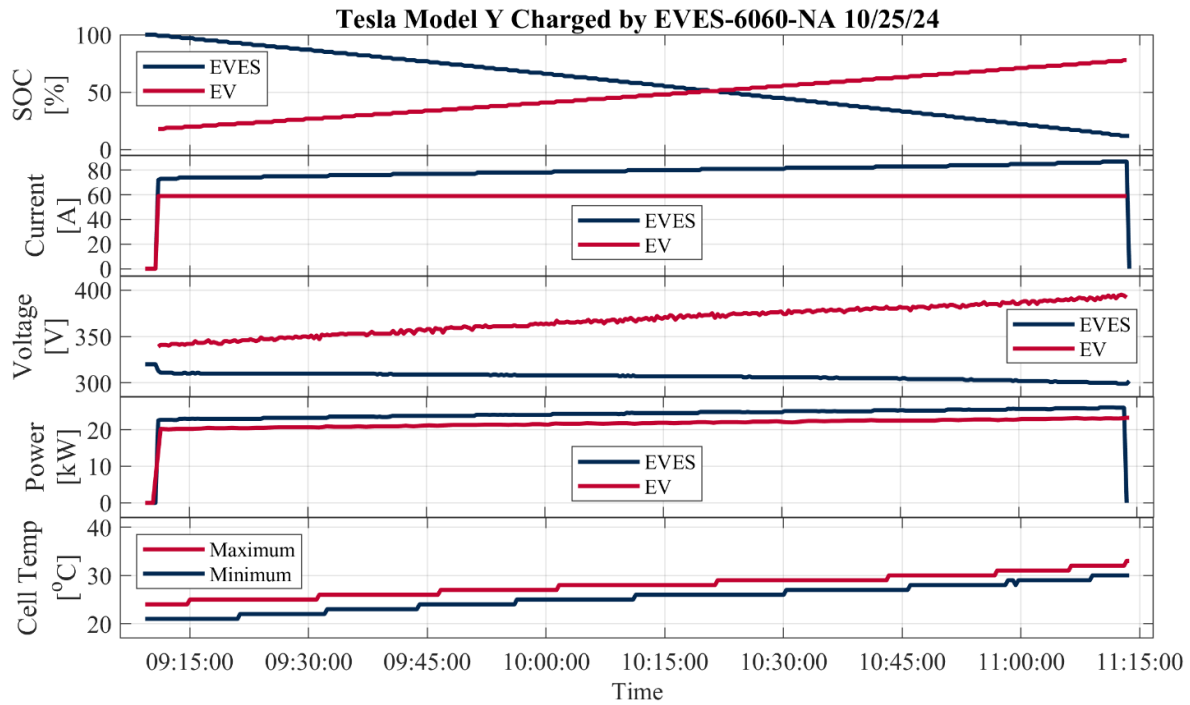
**Figure A.9: EVES and EV SOC, current, voltage, power, and minimum and maximum battery cell temperatures for charging session of Chevrolet Bolt by the EVES-6060-NA unit**



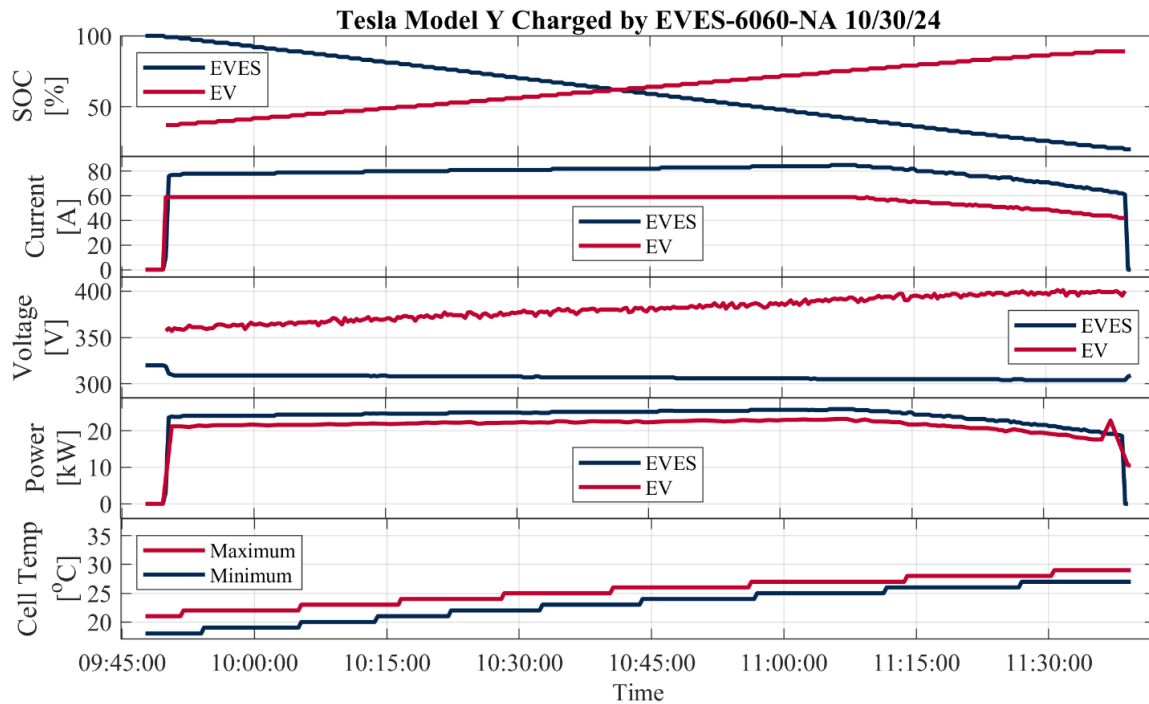
**Figure A.10: EVES and EV SOC, current, voltage, power, and minimum and maximum battery cell temperatures for charging session of Chevrolet Silverado by the EVES-6060-NA unit**



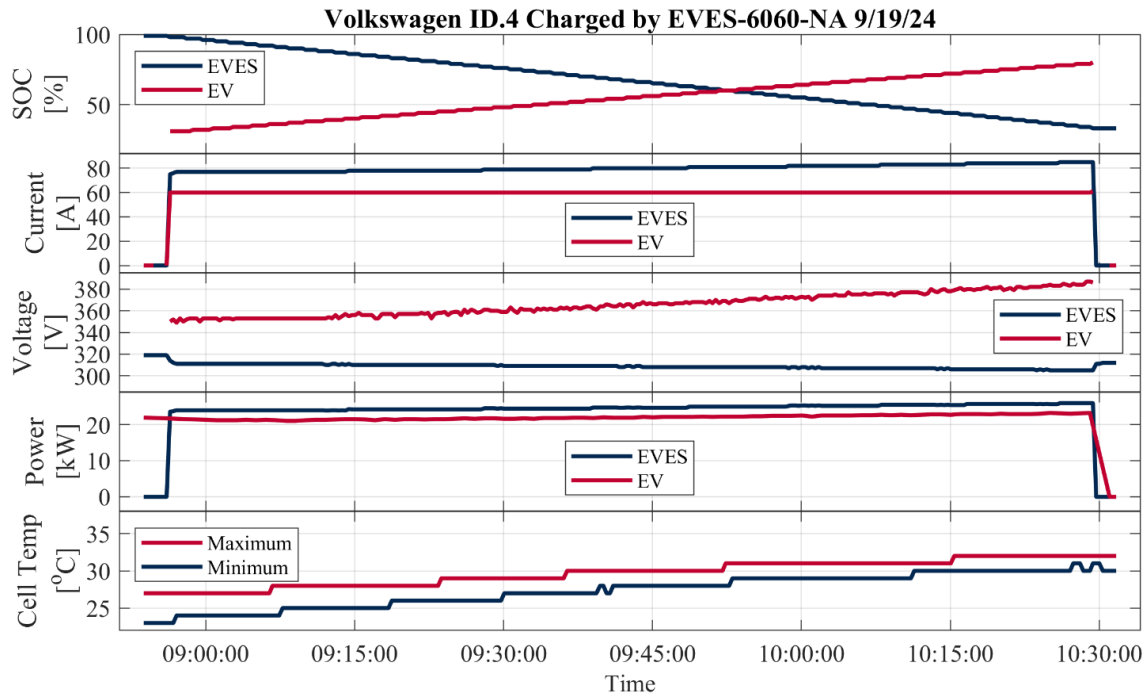
**Figure A.11: EVES and EV SOC, current, voltage, power, and minimum and maximum battery cell temperatures for charging session of Tesla Model Y by the EVES-6060-NA unit**



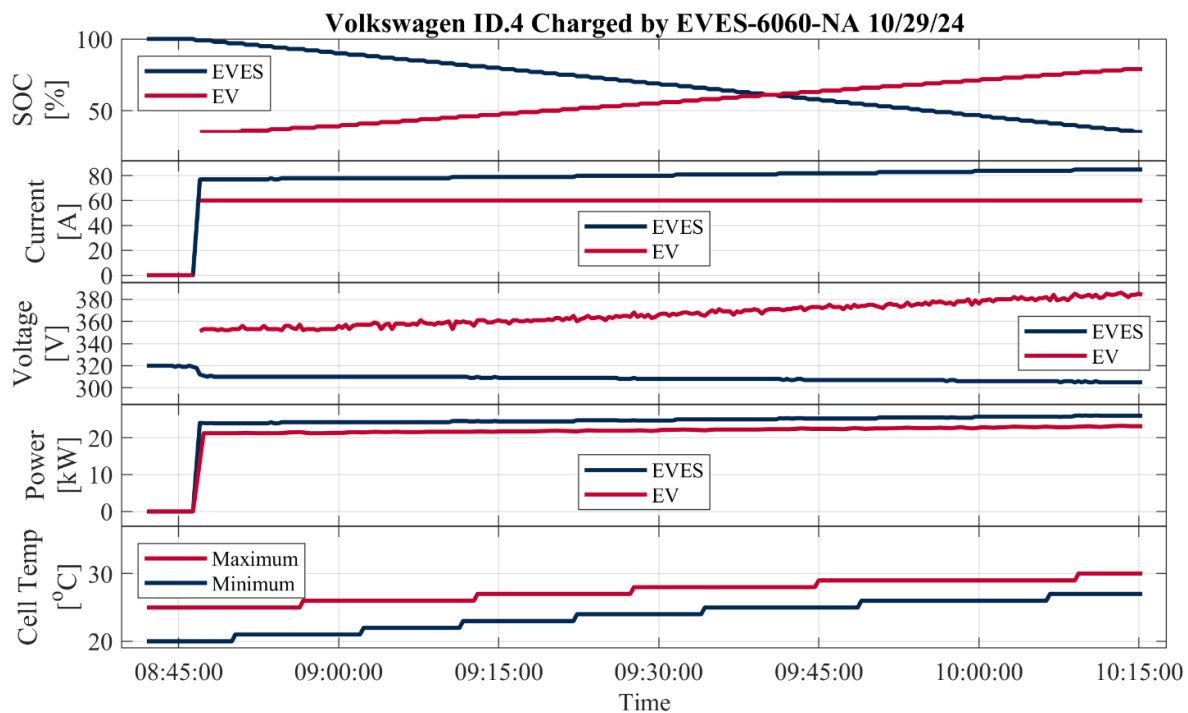
**Figure A.12: EVES and EV SOC, current, voltage, power, and minimum and maximum battery cell temperatures for charging session of Tesla Model Y by the EVES-6060-NA unit**



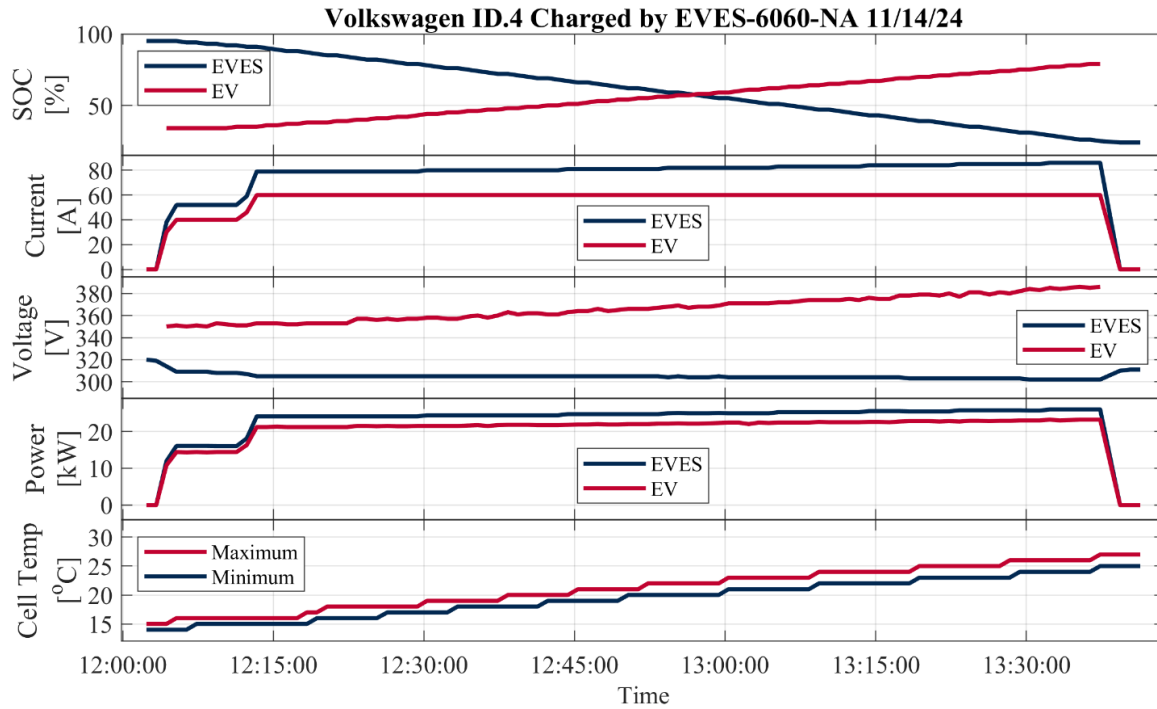
**Figure A.13: EVES and EV SOC, current, voltage, power, and minimum and maximum battery cell temperatures for charging session of Tesla Model Y by the EVES-6060-NA unit**



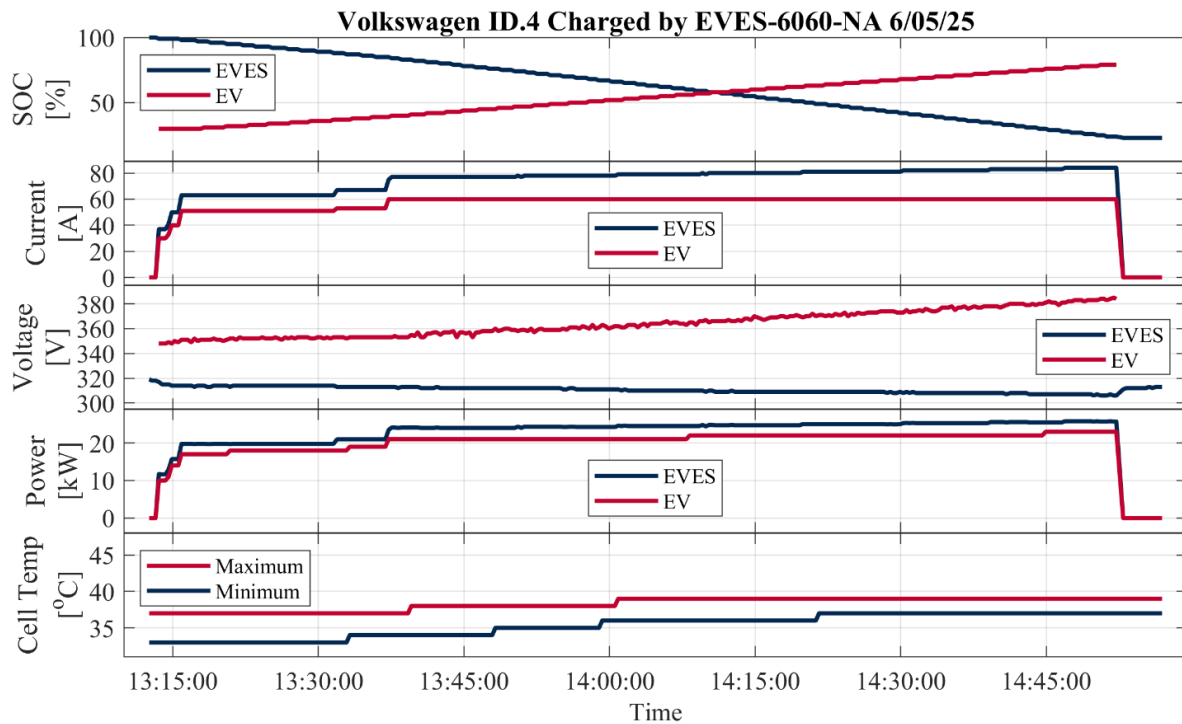
**Figure A.14: EVES and EV SOC, current, voltage, power, and minimum and maximum battery cell temperatures for charging session of Volkswagen ID.4 by the EVES-6060-NA unit**



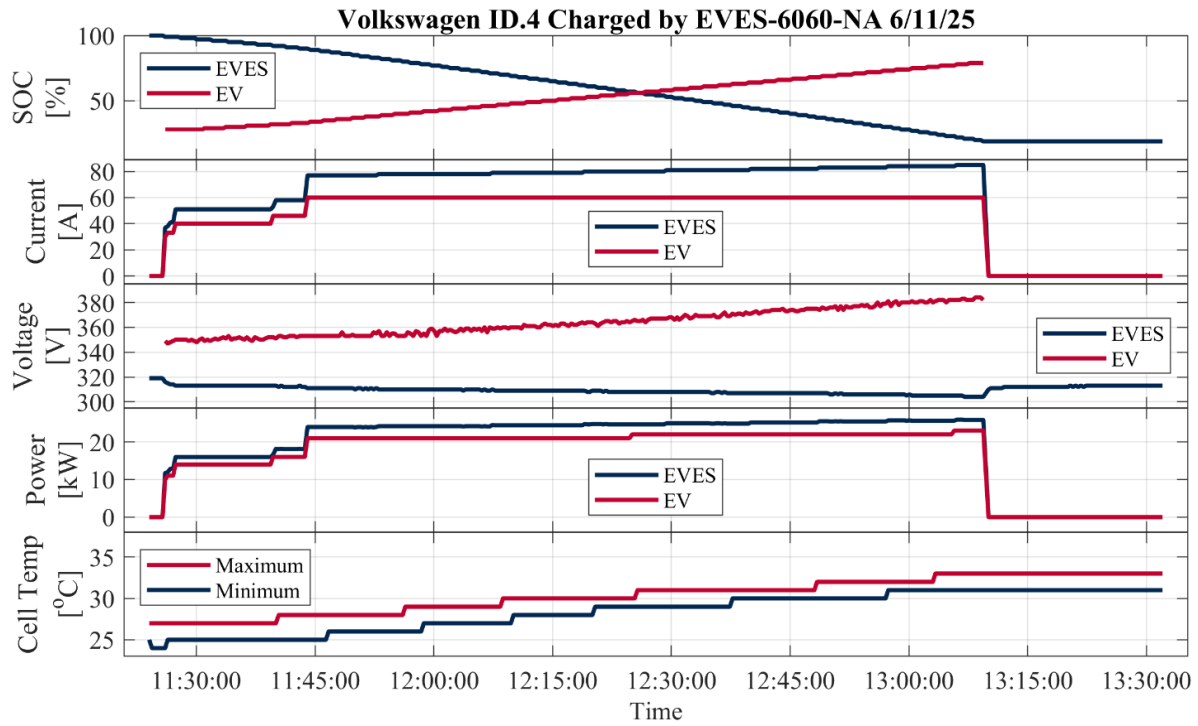
**Figure A.15: EVES and EV SOC, Current, Voltage, Power, and Min and Max Battery Cell temperatures for charging session of Volkswagen ID.4 by the EVES-6060-NA unit**



**Figure A.16: EVES and EV SOC, current, voltage, power, and minimum and maximum battery cell temperatures for charging session of Volkswagen ID.4 by the EVES-6060-NA unit**

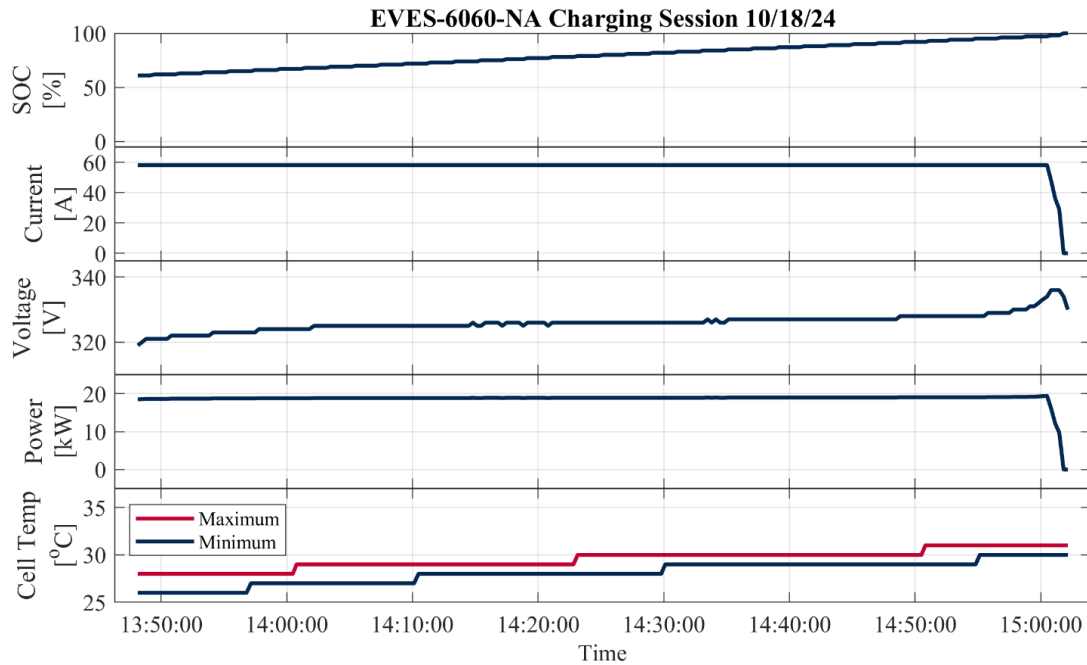


**Figure A.17: EVES and EV SOC, current, voltage, power, and minimum and maximum battery cell temperatures for charging session of Volkswagen ID.4 by the EVES-6060-NA unit**

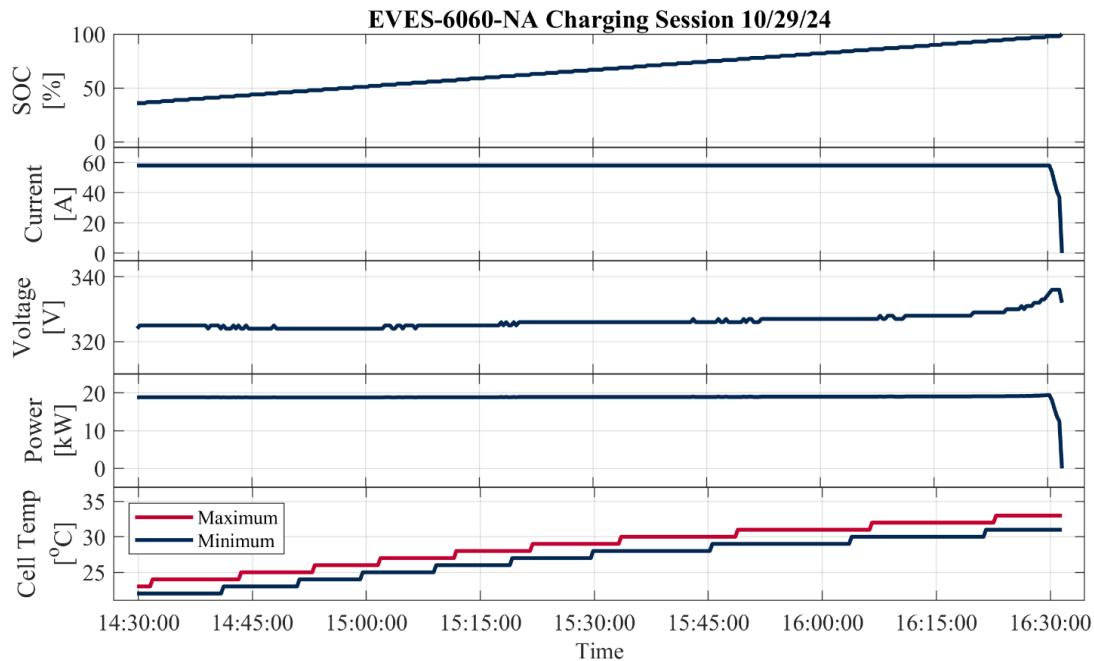


**Figure A.18: EVES and EV SOC, current, voltage, power, and minimum and maximum battery cell temperatures for charging session of Volkswagen ID.4 by the EVES-6060-NA unit**

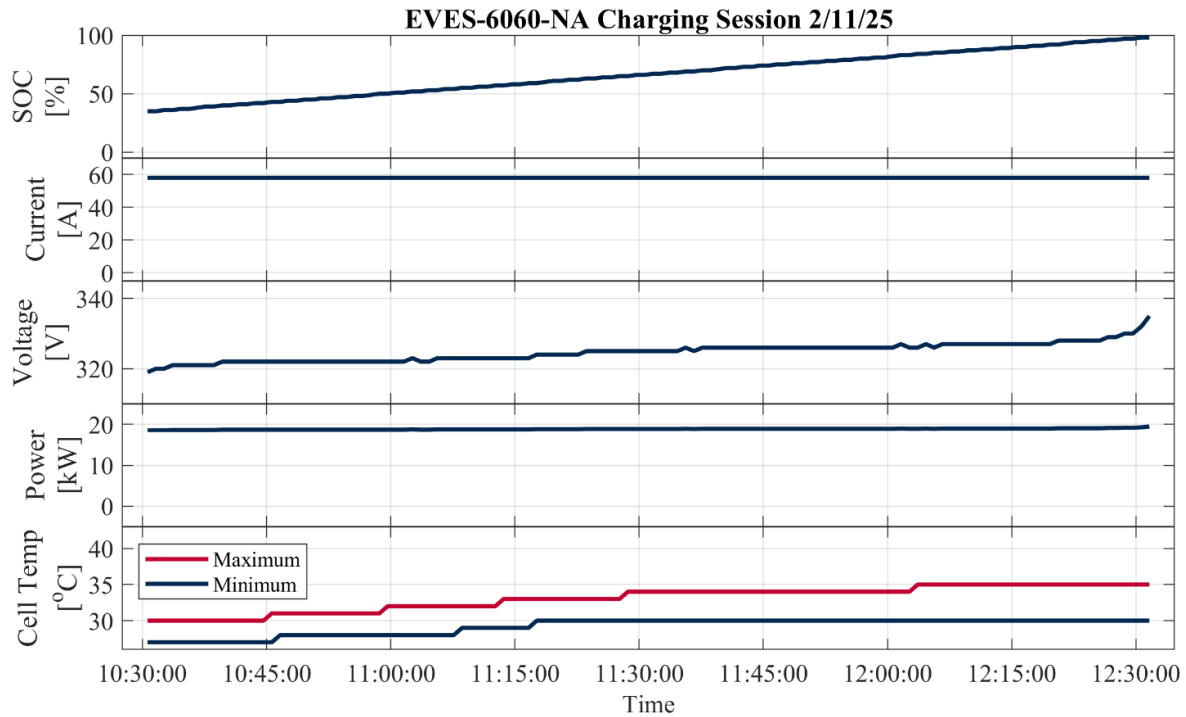
# Grid Charging (480V AC)



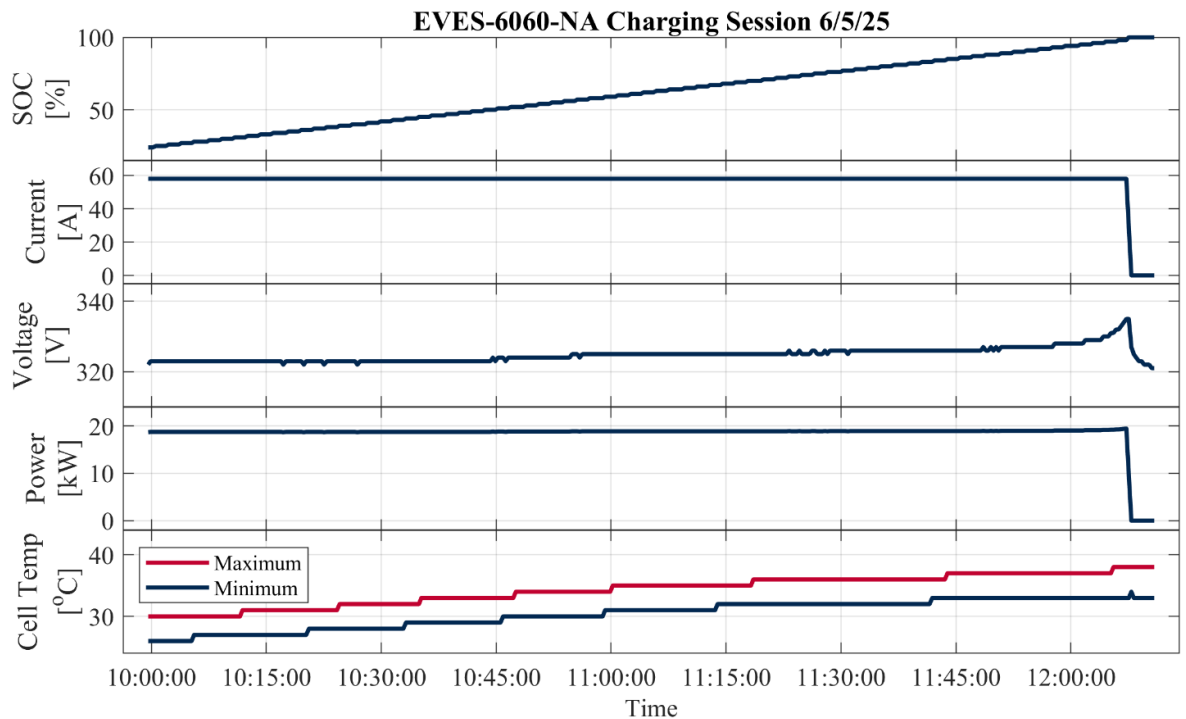
**Figure A.19: SOC, current, voltage, power, and minimum and maximum battery cell temperatures for charging session of EVES-6060-NA by 3-phase 480V AC power at ATIRC facility**



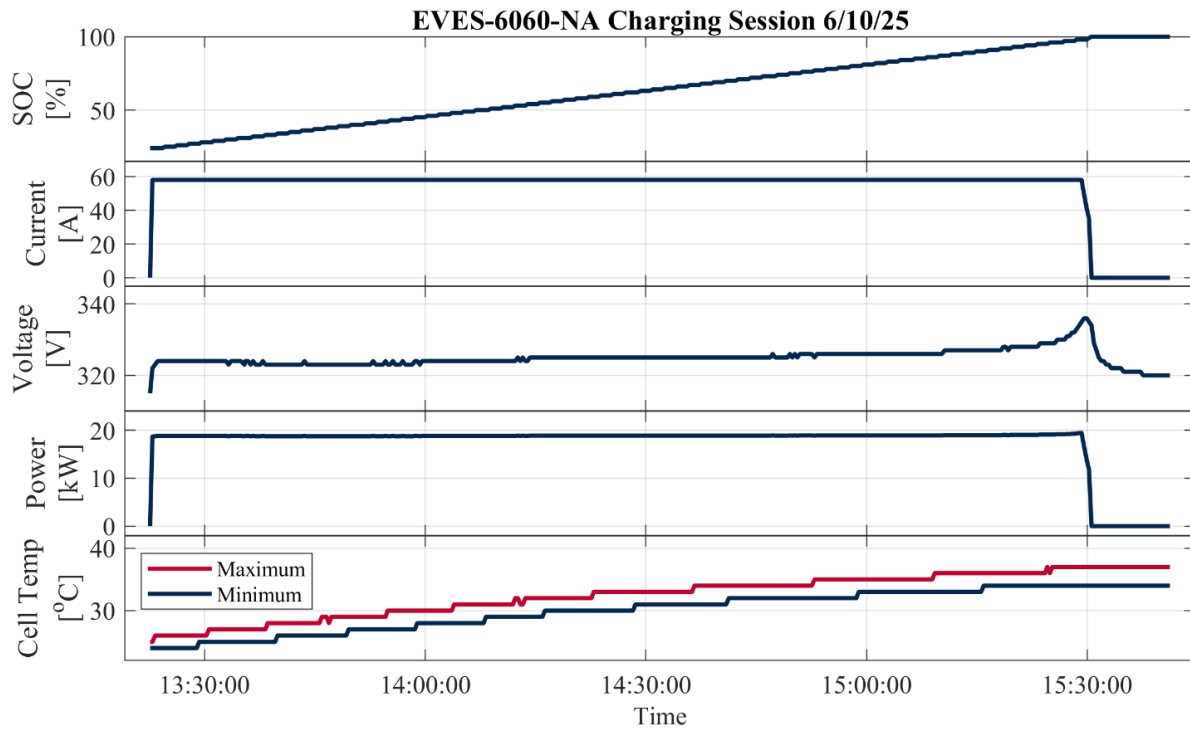
**Figure A.20: SOC, current, voltage, power, and minimum and maximum battery cell temperatures for charging session of EVES-6060-NA by 3-phase 480V AC power at ATIRC facility**



**Figure A.21: SOC, current, voltage, power, and minimum and maximum battery cell temperatures for charging session of EVES-6060-NA by 3-phase 480V AC power at ATIRC facility**

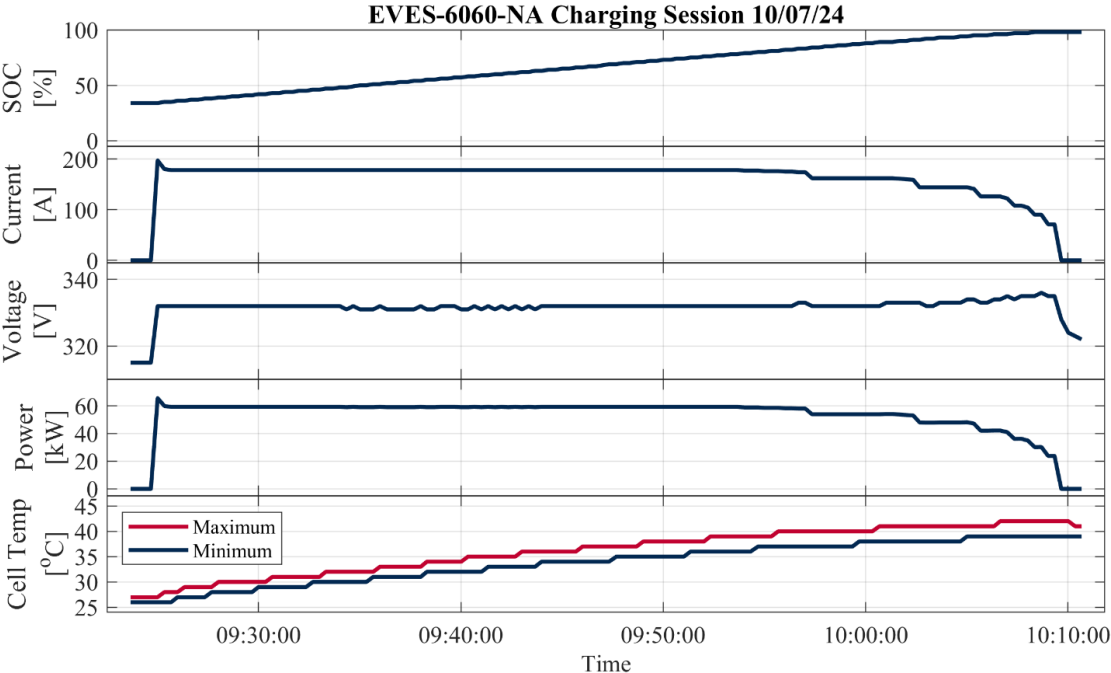


**Figure A.22: SOC, current, voltage, power, and minimum and maximum battery cell temperatures for charging session of EVES-6060-NA by 3-phase 480V AC power at ATIRC facility**

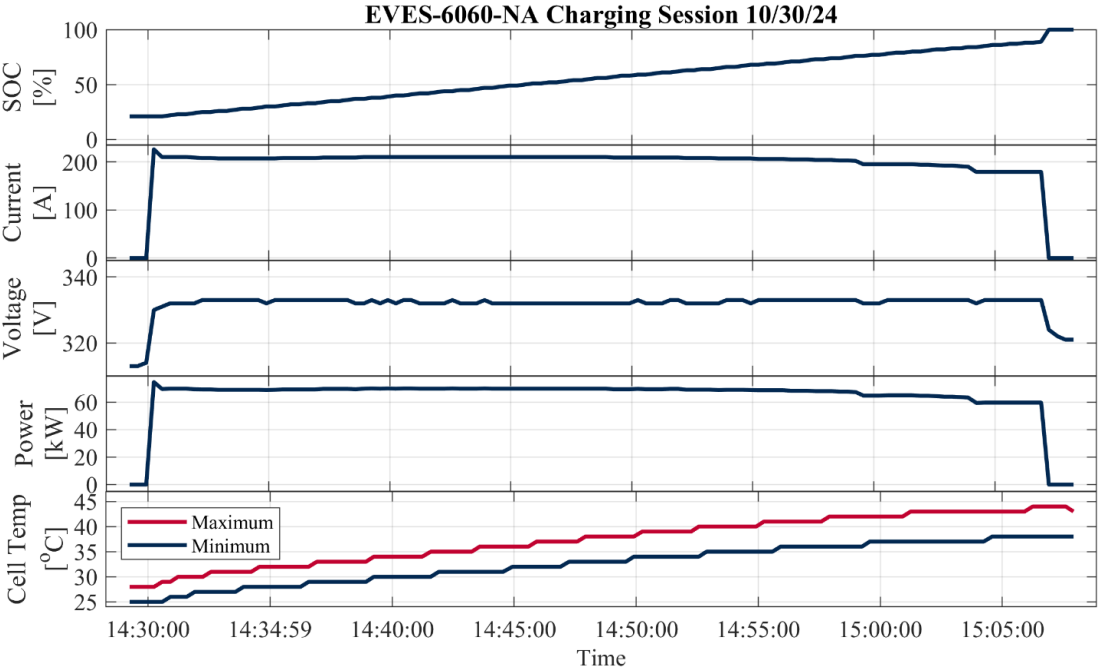


**Figure A.23: SOC, current, voltage, power, and minimum and maximum battery cell temperatures for charging session of EVES-6060-NA by 3-phase 480V AC power at ATIRC facility**

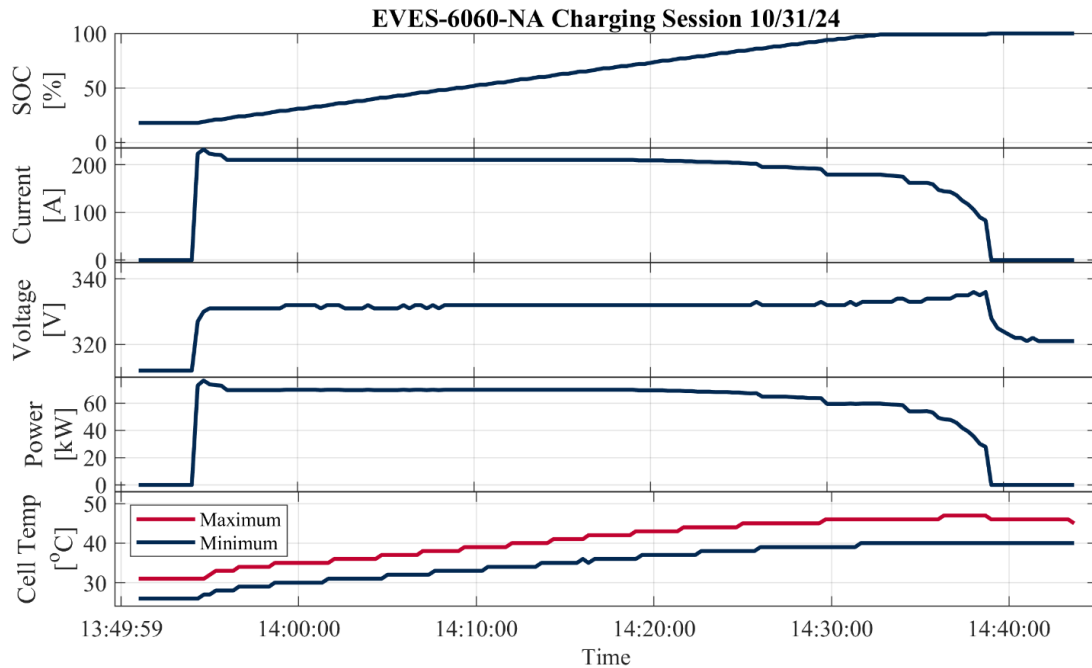
# DC Fast Charging



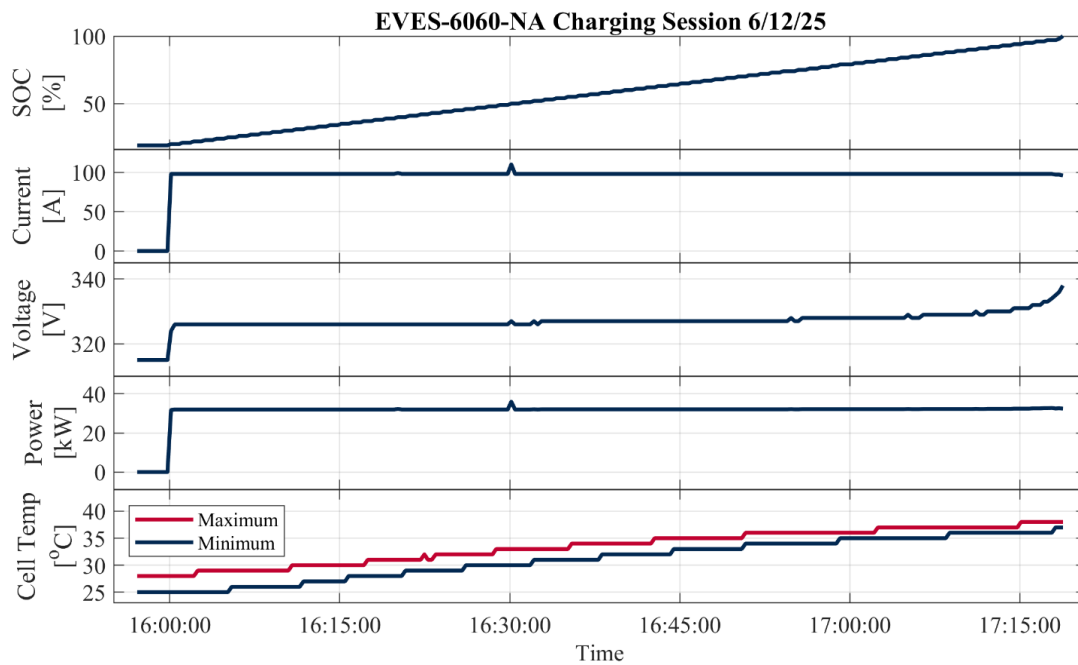
**Figure A.24: SOC, current, voltage, power, and minimum and maximum battery cell temperatures for charging session of EVES-6060-NA at the Electrify America DCFC located at the Davis Bank of America**



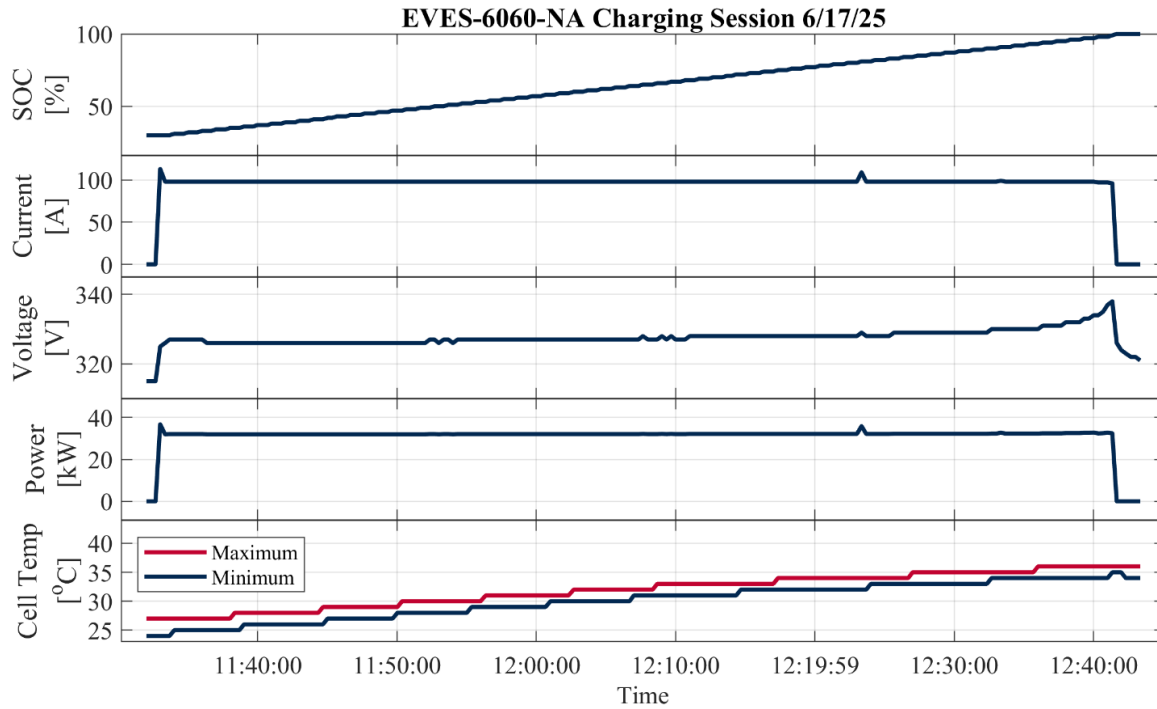
**Figure A.25: SOC, current, voltage, power, and minimum and maximum battery cell temperatures for charging session of EVES-6060-NA at the Electrify America DCFC located at the Davis Bank of America**



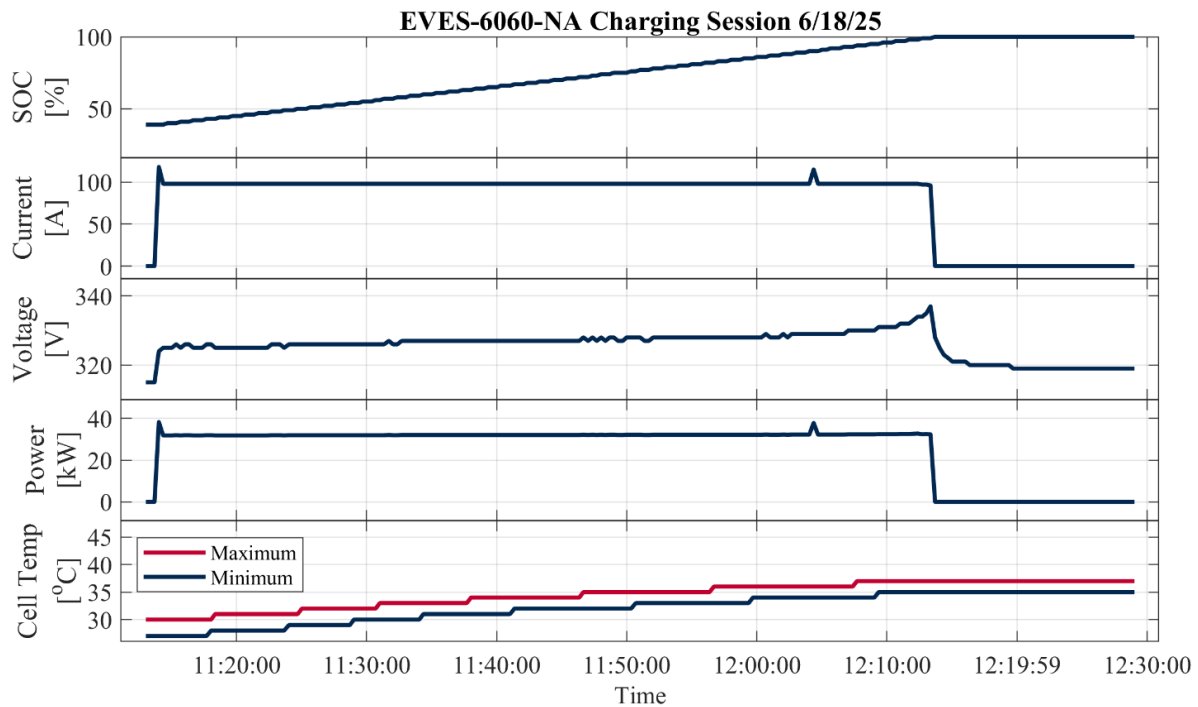
**Figure A.26: SOC, current, voltage, power, and minimum and maximum battery cell temperatures for charging session of EVES-6060-NA at the Electrify America DCFC located at the Davis Bank of America**



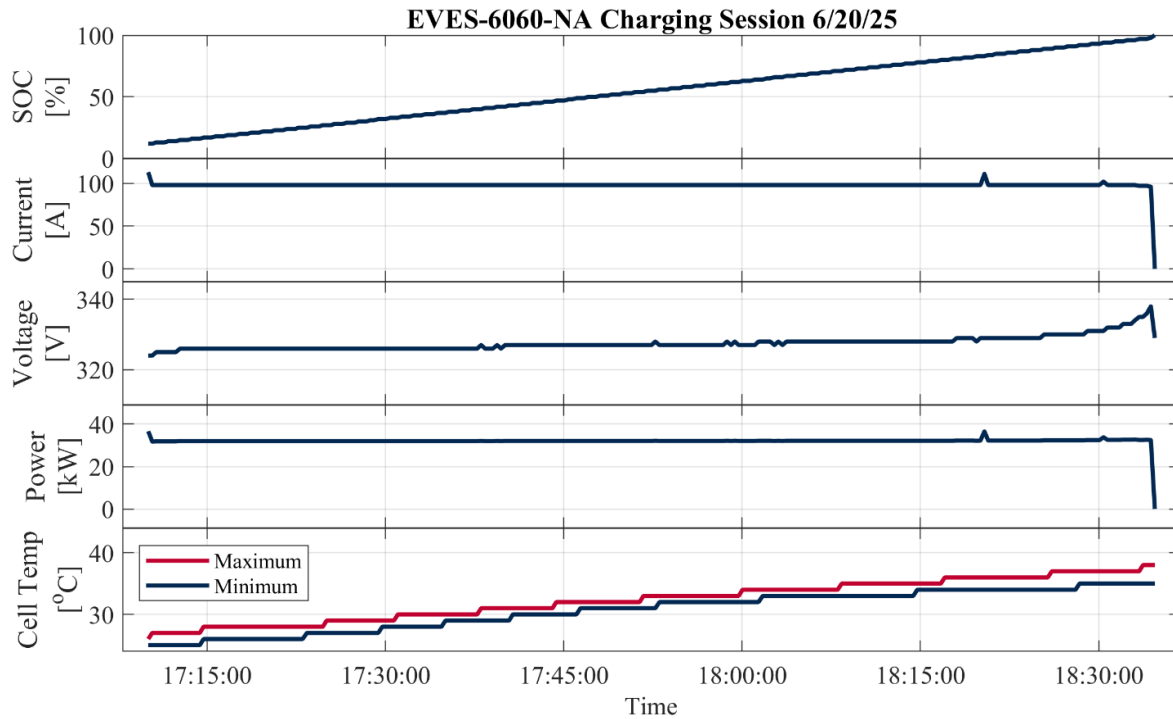
**Figure A.27: SOC, current, voltage, power, and minimum and maximum battery cell temperatures for a charging session of EVES-6060-NA by the Davis EVgo DCFC**



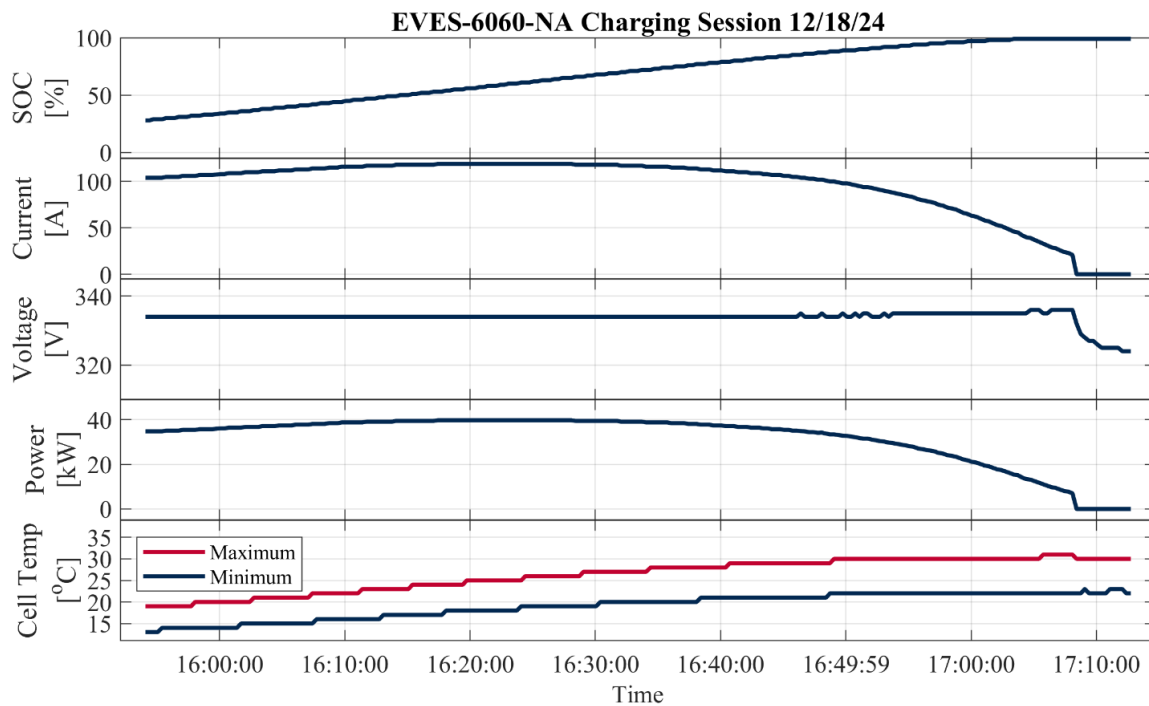
**Figure A.28: SOC, current, voltage, power, and minimum and maximum battery cell temperatures for a charging session of EVES-6060-NA by the Davis EVgo DCFC**



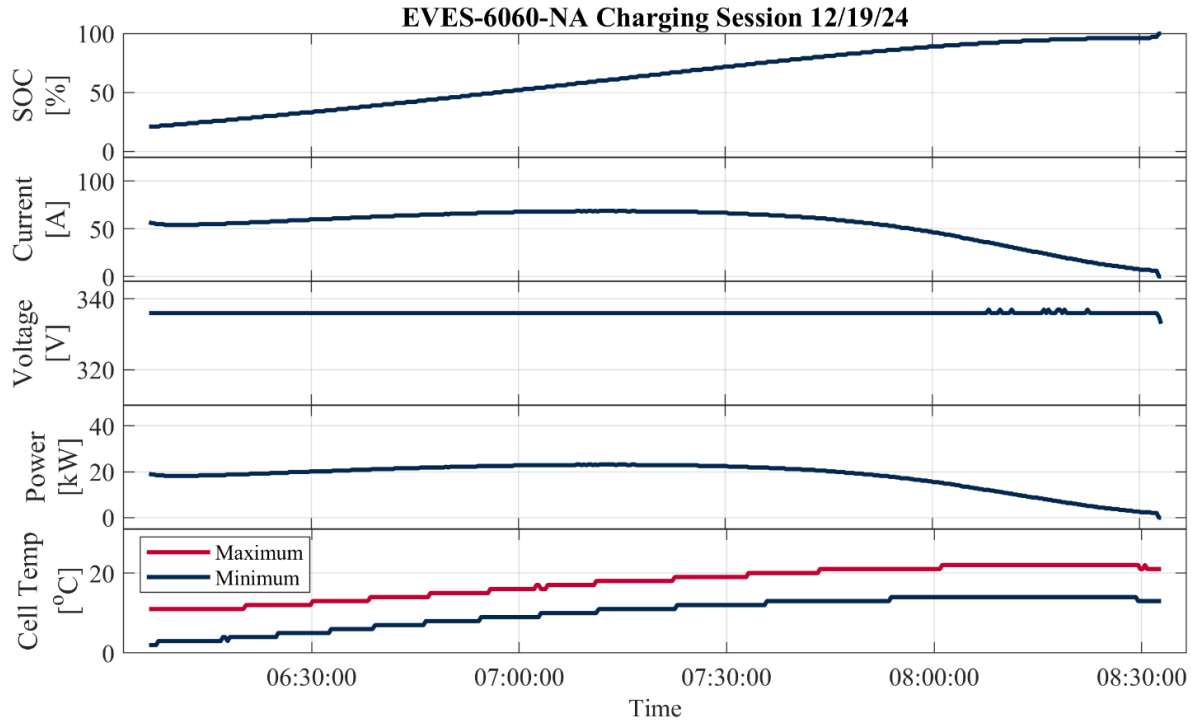
**Figure A.29: SOC, current, voltage, power, and minimum and maximum battery cell temperatures for a charging session of EVES-6060-NA by the Davis EVgo DCFC**



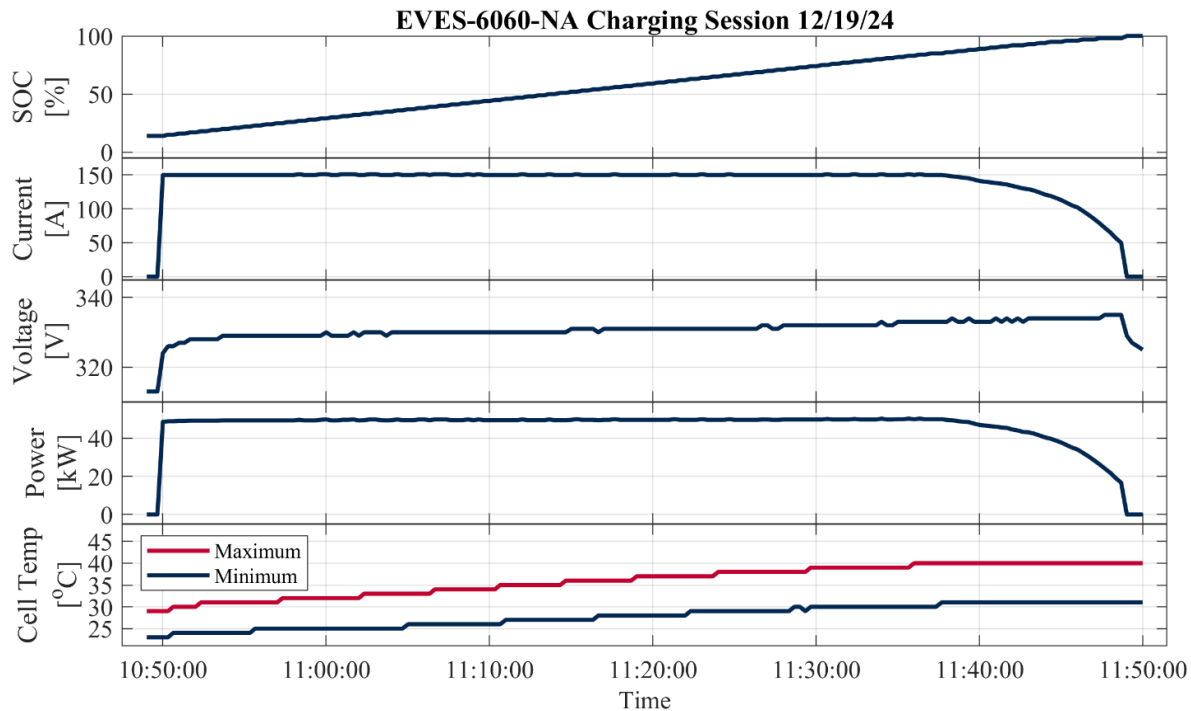
**Figure A.30: SOC, current, voltage, power, and minimum and maximum battery cell temperatures for a charging session of EVES-6060-NA by the Davis EVgo DCFC**



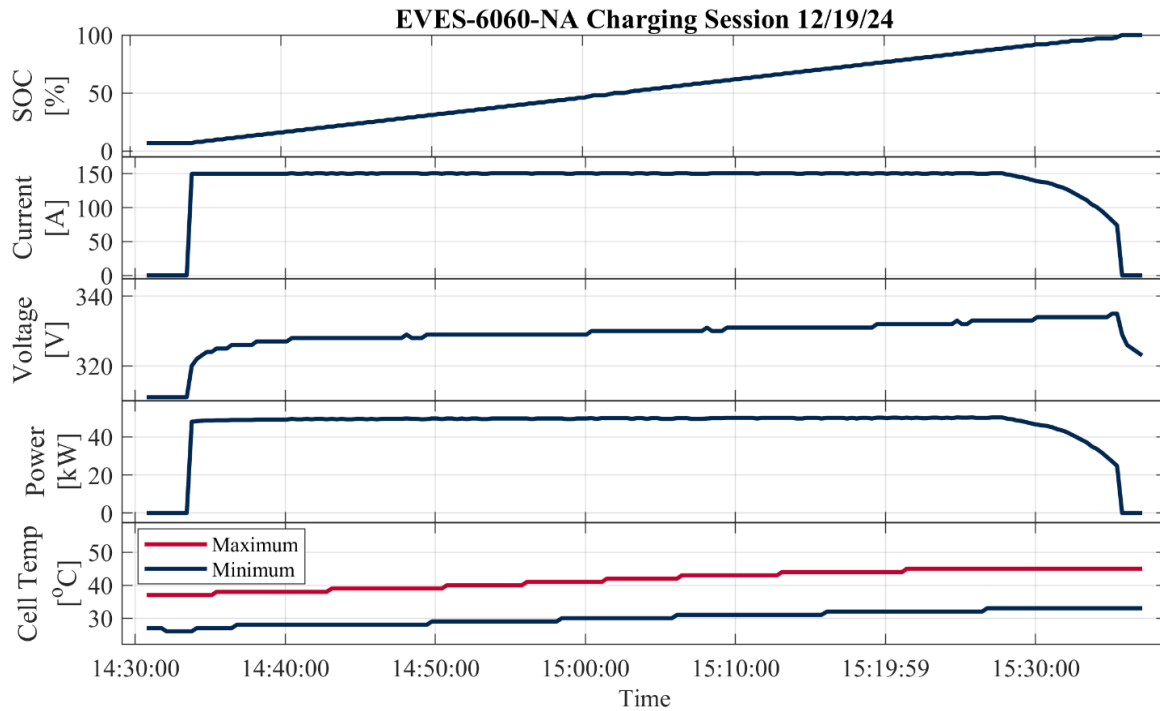
**Figure A.31: SOC, current, voltage, power, and minimum and maximum battery cell temperatures for charging session of EVES-6060-NA at the ChargePoint DCFC located in Emigrant Gap**



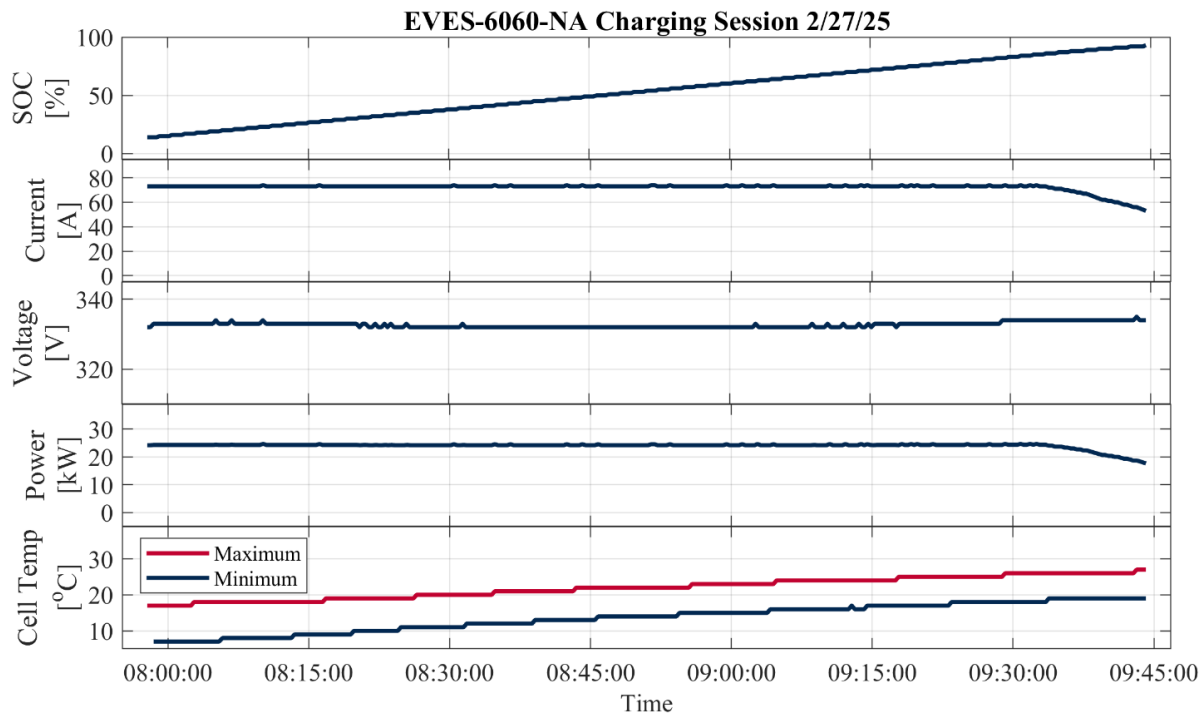
**Figure A.32: SOC, current, voltage, power, and minimum and maximum battery cell temperatures for charging session of EVES-6060-NA at the ChargePoint DCFC located in Emigrant Gap**



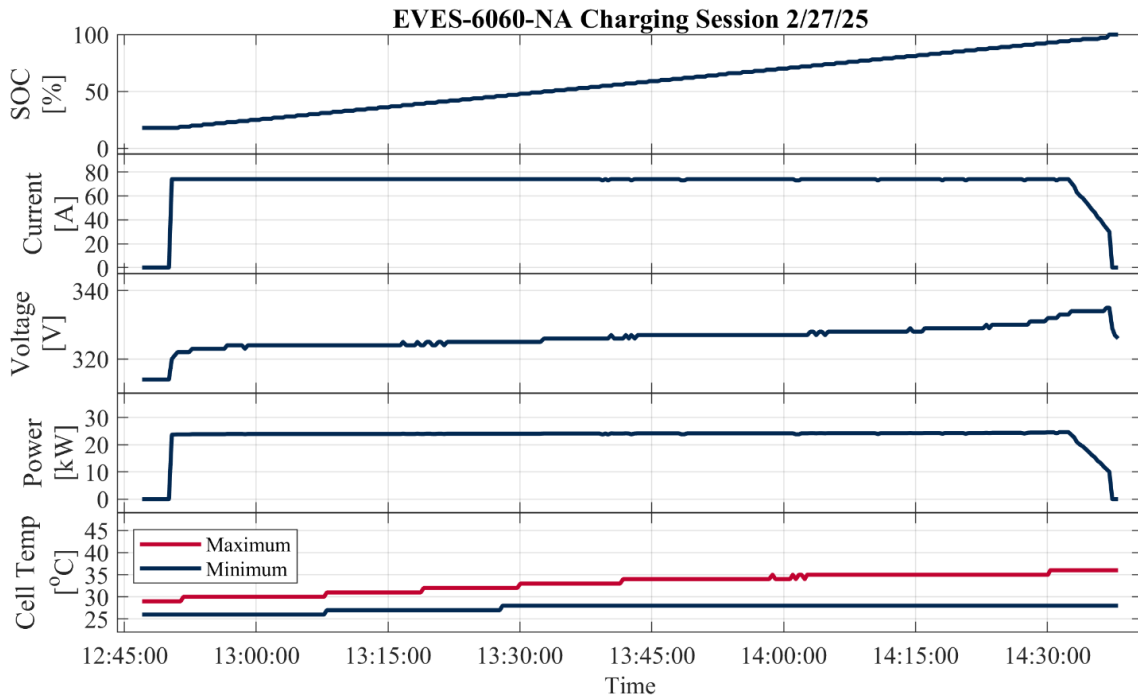
**Figure A.33: SOC, current, voltage, power, and minimum and maximum battery cell temperatures for charging session of EVES-6060-NA at the ChargePoint DCFC located in Emigrant Gap**



**Figure A.34: SOC, current, voltage, power, and minimum and maximum battery cell temperatures for charging session of EVES-6060-NA at the ChargePoint DCFC located in Emigrant Gap**



**Figure A.35: SOC, current, voltage, power, and minimum and maximum battery cell temperatures for charging session of EVES-6060-NA at the ChargePoint DCFC located in Emigrant Gap**



**Figure A.36: SOC, current, voltage, power, and minimum and maximum battery cell temperatures for charging session of EVES-6060-NA at the ChargePoint DCFC located in Emigrant Gap**

# Appendix B:

## EVES-6060-NA Operating Instructions

**Note: EVES-6060-NA has been compatible only with select DCFC stations and EVs. Document any compatibility issues for future reference.**

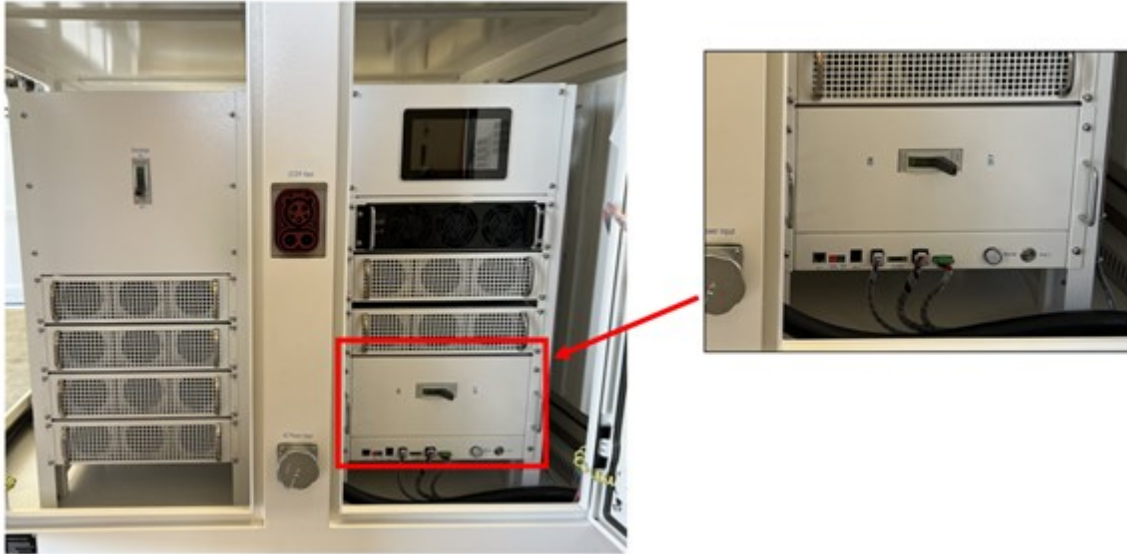
**Warning: do not charge an EV at the same time that the EVES-6060-NA battery is being charged.**

### Before Energizing

1. Ensure that the truck is not running.
2. Ensure that discharge switch is set to "OFF" position.
3. Apply wheel chucks to the truck and place keys next to chucks to ensure that they are removed before driving.
4. Before discharging the unit to another EV, ensure that the EV has been driven for at least five minutes.
5. Record the following information:
  - a. Date, time, and location of charge.
  - b. Recipient EV make, model, and year.
  - c. Minimum SOC of EV at the beginning of charging session.
  - d. Maximum SOC of EVES-6060 at the beginning of charging session.
  - e. Minimum SOC of EVES-6060 at the end of charging session
  - f. Maximum SOC of EV at the end of charging session
  - g. Vehicle errors should be documented.
  - h. Drive the vehicle after test for at least 5 minutes. Document any issues.
6. Ensure that a video is taken when connecting the charger to another EV and when the charger is connected to another DCFC station.

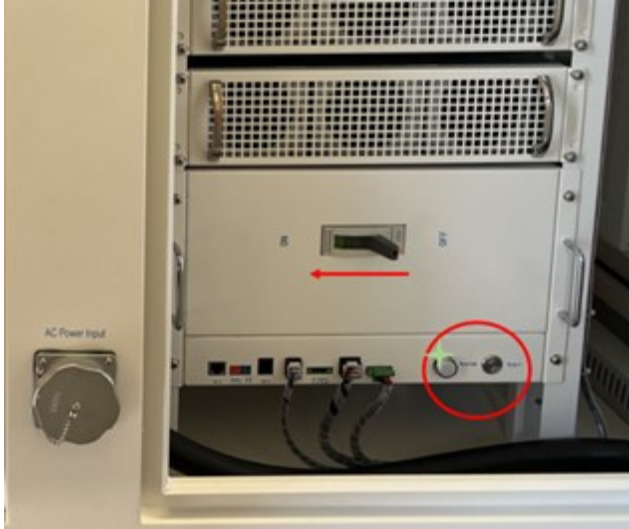
## Charging from Another DCFC (DC)

1. Ensure that EVES-6060-NA is fixed to the trailer and/or on a level surface.
2. Position EVES-6060-NA such that there is some slack in the external charging cable when it is plugged in.
3. Open front doors using keys to access master control switch, discharge switch, and start button.



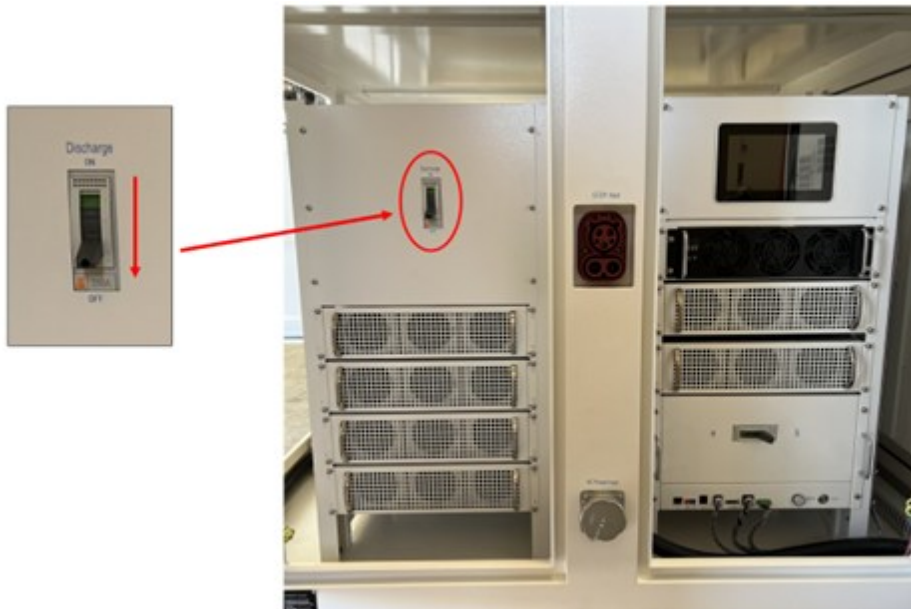
**Figure B.1: Internal view of the EVES-6060-NA system, highlighting the master control switch, discharge switch, and start button**

4. Flip master control switch to "ON" position (on the master control switch panel to the right.)



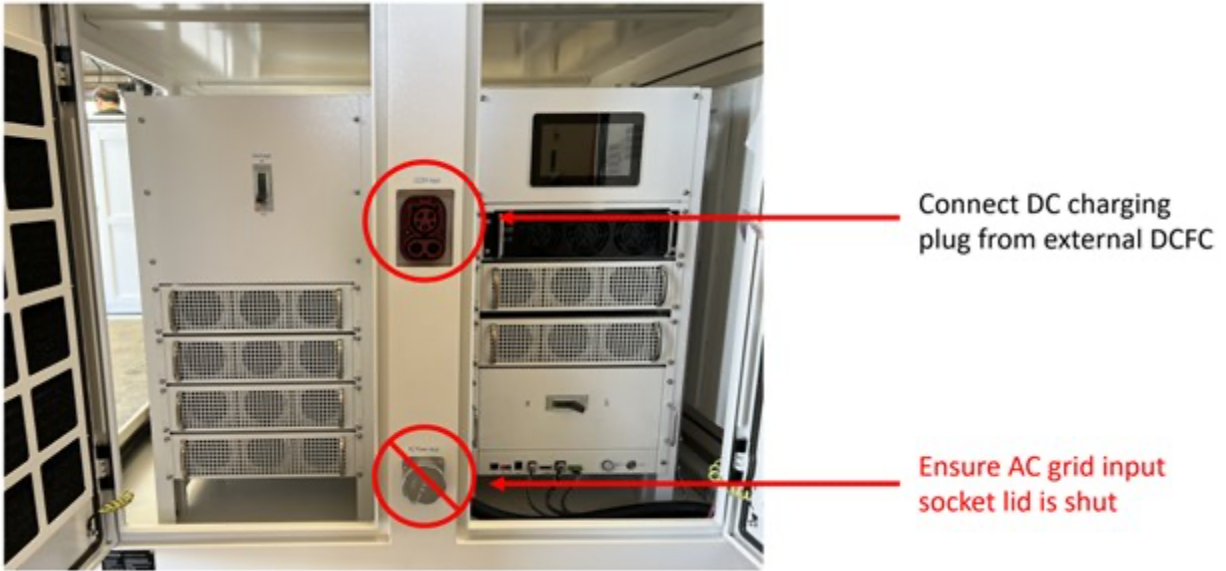
**Figure B.2: Close-up of the master control switch panel, highlighting the master control switch (red arrow) and the START button (red circle), which must be activated to initiate system operation**

5. Press the “START” button on the master control switch panel (on the master control switch panel, to the right.)
  - a. Ensure that the “SYSTEM” light turns green before proceeding.
6. Flip discharge switch to the “OFF” position.



**Figure B.3: Location and close-up view of the discharge switch, which must be flipped to the “OFF” position before proceeding with the charging process**

7. Ensure that the AC grid input socket lid is shut.



**Figure B.4: DC charging plug connection and AC grid input socket lid closure requirement**

8. Ensure that “Self-Test” status reads “Success” before proceeding. If status reads “Not Successful,” turn the master power switch to “OFF” and restart the unit.
9. Connect external DCFC cable to DC socket on EVES-6060.
10. Blue charging light on the front right door will illuminate while charging. Battery status and SOC will be displayed for both the EVES-6060-NA and external unit while charging.
  - a. **Do not disconnect the charging cable from EVES-6060 input during charging. Ensure that the external unit stops delivering charge before removing the cable.**



**Figure B.5: Charging status display on the EVES-6060 interface during operation**

11. Unplug charging cable when finished charging, ensuring that charge is no longer being delivered to unit.
12. Turn master control switch to "OFF" position.

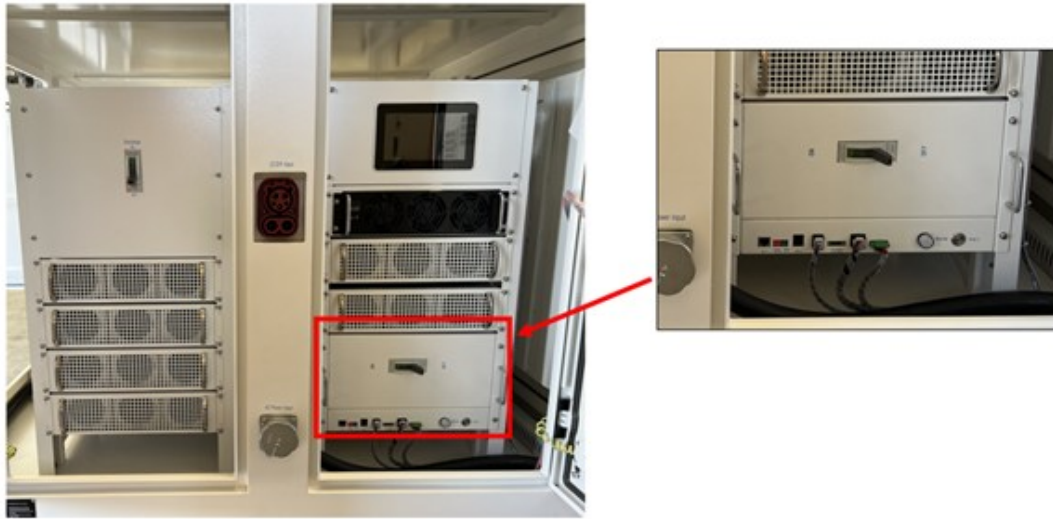


**Figure B.6: Turning the master control switch to "OFF" before closing and locking the unit**

13. Close doors and lock using keys.

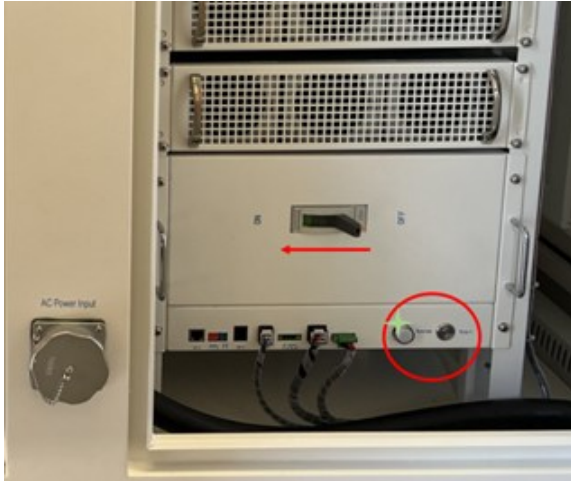
## Charging from Grid (AC)

1. Ensure that EVES-6060-NA is fixed to trailer and/or on a level surface.
2. Position EVES-6060-NA such that there is some slack in the external charging cable while plugged in.
3. Open front doors using keys to access master control switch, discharge switch, and start button.



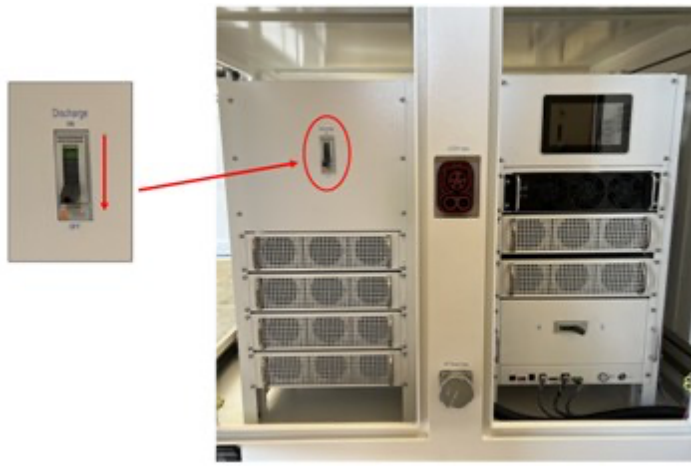
**Figure B.7: Master control switch location for activating grid (AC) charging**

4. Flip master control switch to "ON" position (on the master control switch panel to the right.)
5. Flip discharge switch to "OFF" position.



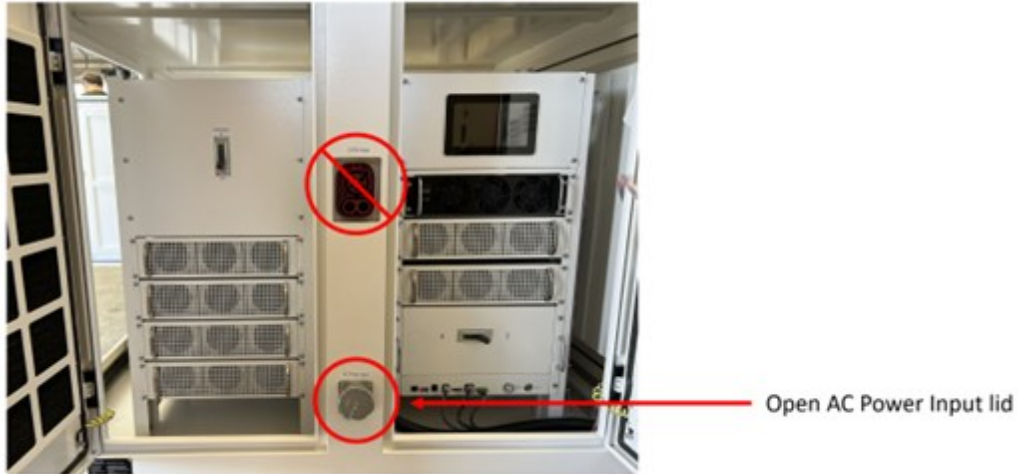
**Figure B.8: START button activation and system status indicator for grid (AC) charging**

6. Press the “START” button on the master control switch panel (on the master control switch panel to the right.)
  - a. Ensure that the “SYSTEM” light turns green before proceeding.



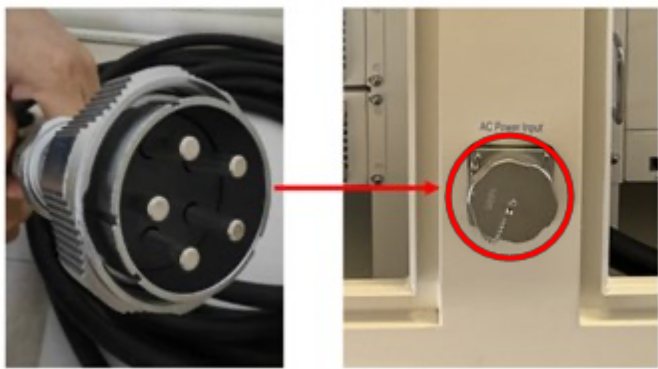
**Figure B.9: Discharge switch location and activation for AC charging setup**

7. The AC charging cable for the unit is connected to a panel found in the eastern wall of ATIRC. Open the panel and flip the switch to the “ON” position.
8. Open AC power input lid by turning lid counterclockwise. The DC input plug will not be used.



**Figure B.10: Opening the AC power input lid for grid (AC) charging connection**

9. Insert the 5-pin connector and fasten the outer ring to the socket by turning clockwise.



**Figure B.11: Inserting and securing the 5-pin connector into the AC power input socket**

10. Blue charging light on the front right door will illuminate while charging. Battery status and SOC will be displayed for the EVES-6060-NA.
  - a. **Do not disconnect the charging cable from EVES-6060-NA input during charging. Ensure that charge is not being delivered before removing the cable.**

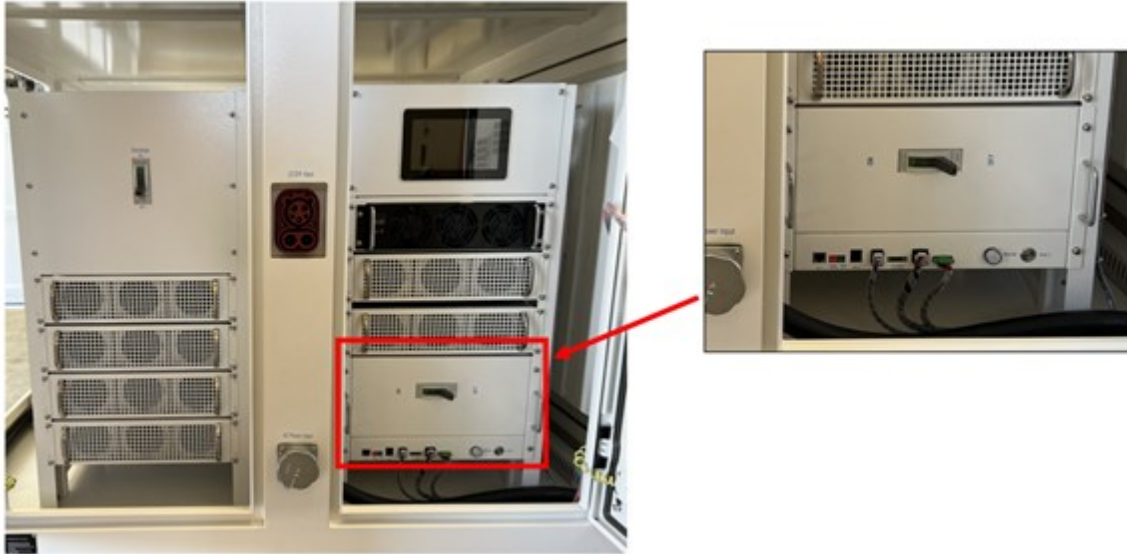


**Figure B.12: Charging status display and indicator lights during AC charging operation**

11. When charging is complete, turn the panel switch to the “OFF” position.
12. Unplug AC charging cable.
13. Close doors and lock using keys.

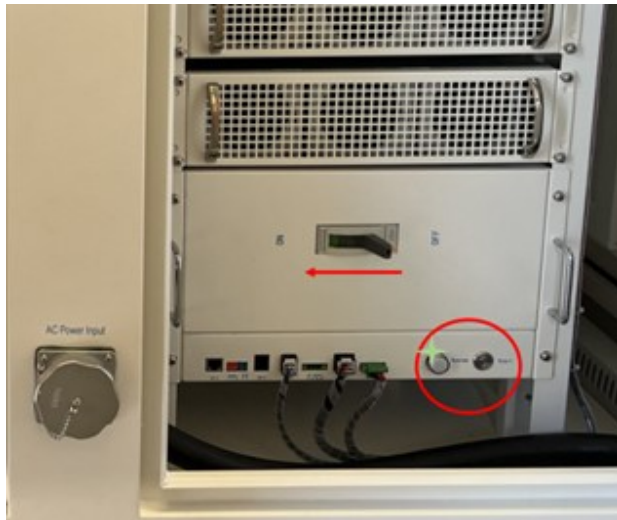
## **Charging an EV**

1. Ensure that EVES-6060-NA is fixed to the trailer and/or on a level surface.
2. Position EVES-6060-NA such that there is some slack in the charging cable while plugged in.
3. Open front doors using keys to access the master control switch, discharge switch, and start button.



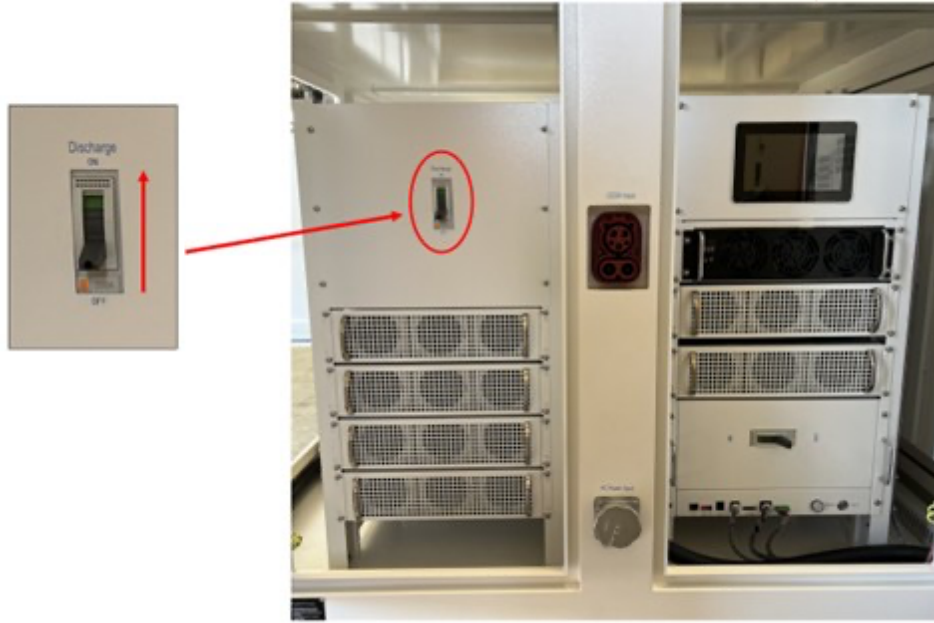
**Figure B.13: Master control switch location for initiating EV charging**

4. Flip master control switch to the “ON” position (on the master control switch panel to the right.)



**Figure B.14: START button and master control switch activation for EV charging**

5. Press the “START” button on the master control switch panel (on the master control switch panel to the right.)
6. Ensure that the “SYSTEM” light turns green before proceeding.
7. Flip the discharge switch to the “ON” position



**Figure B.15: Activation of discharge switch for EV charging**

8. Options for charger socket types that connect to the vehicle will be listed on the screen seen on the front right door. Select the appropriate socket type by touching the screen.
9. Connect the cable to the vehicle.

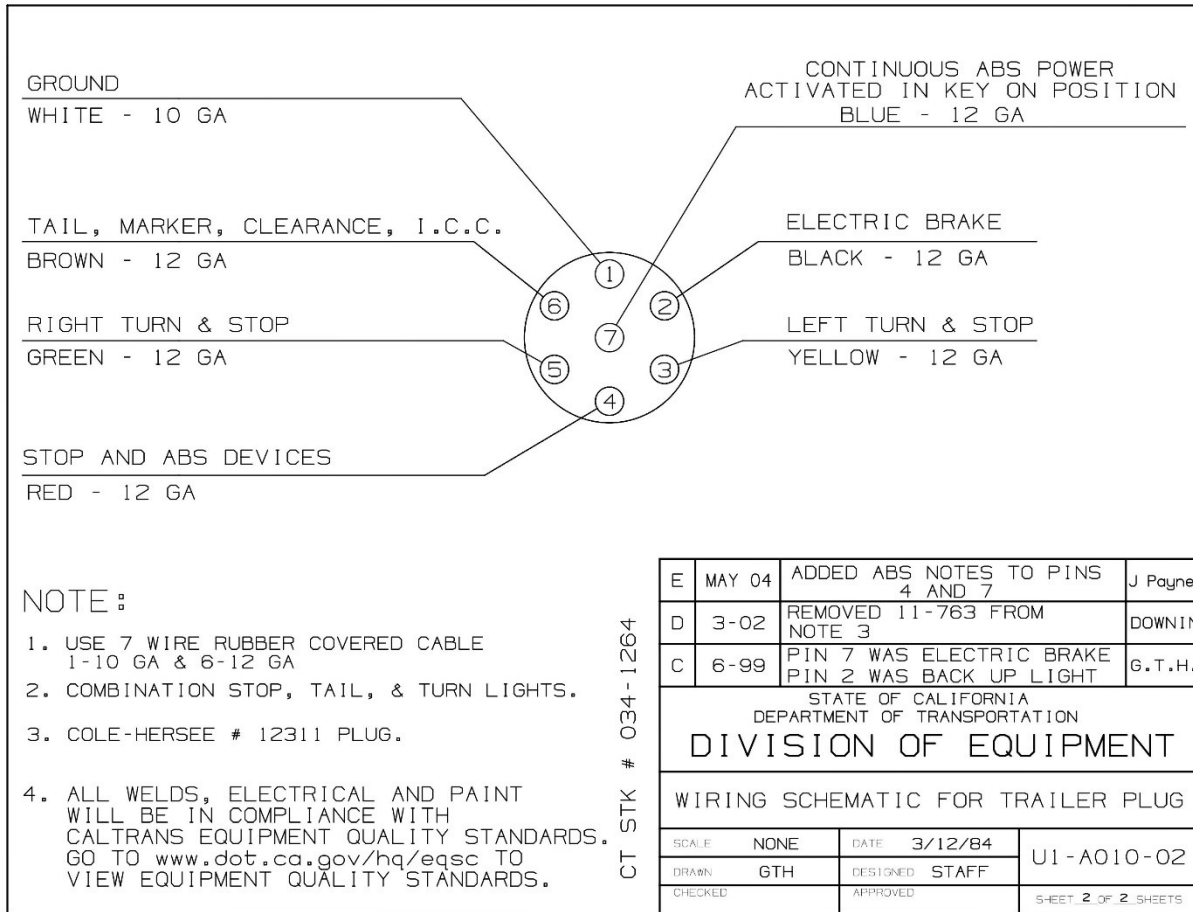


**Figure B.16: Connecting the EVES-6060-NA charger to an EV**

10. When charging is complete, turn the panel switch to the “OFF” position.

11. Unplug AC charging cable.
12. Close doors and lock using keys.

# Appendix C: Drawing for 7-pin Connector for Zieman 1166-S Trailer



**Figure C.1: Drawing for wiring of 7-pin connector for trailer plug**

# Appendix D: Charging Chevrolet Silverado EV with FreeWire Boost Charger 200

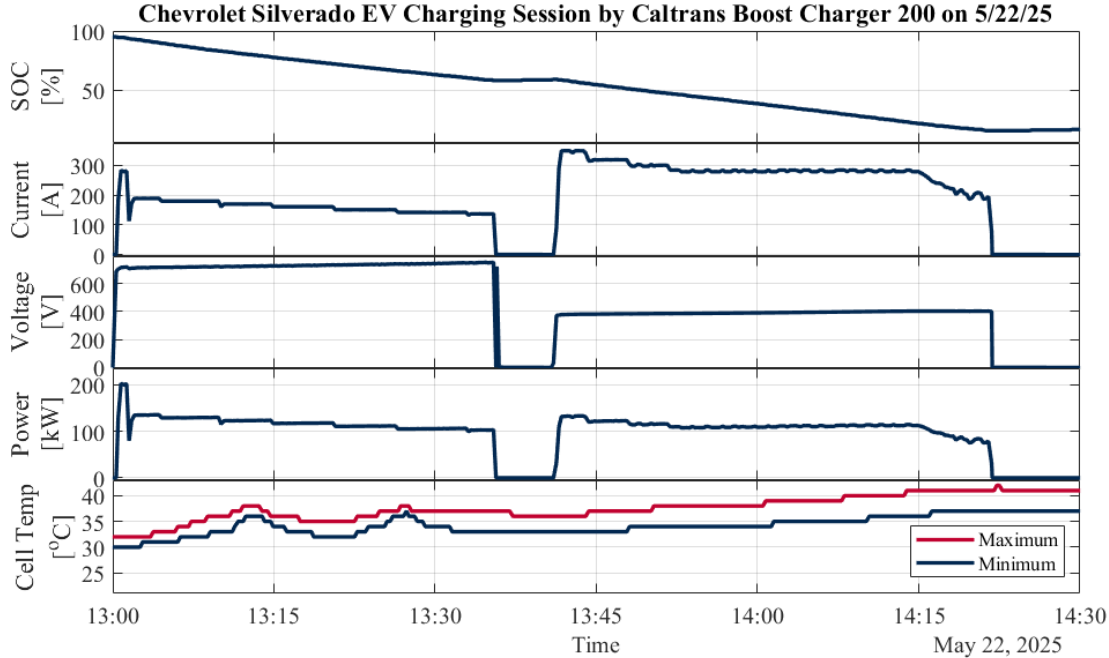
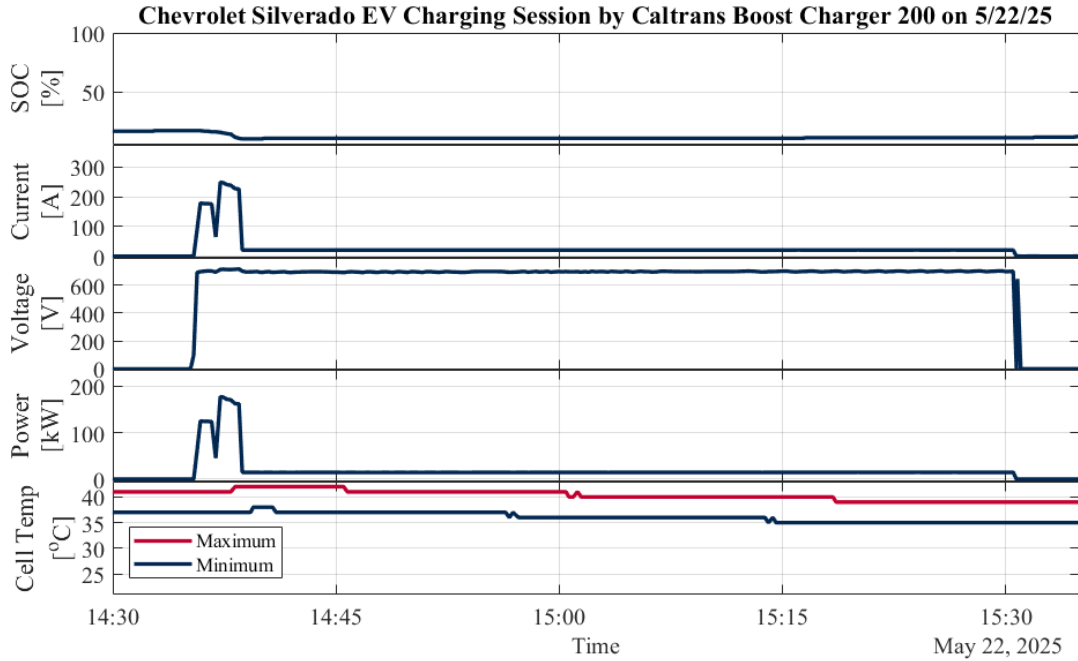
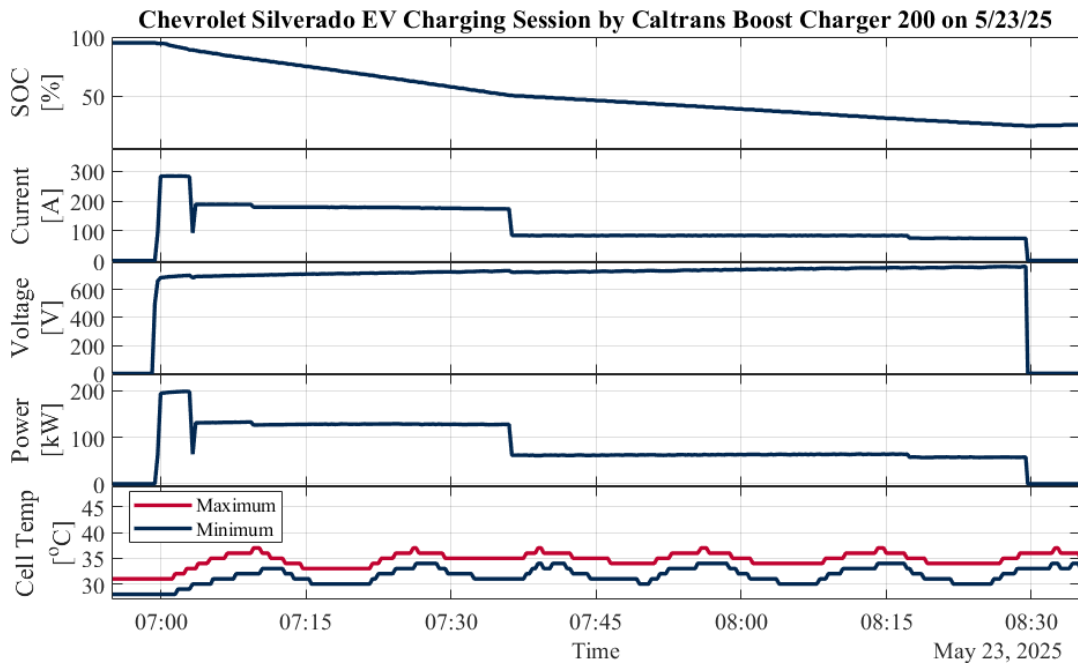


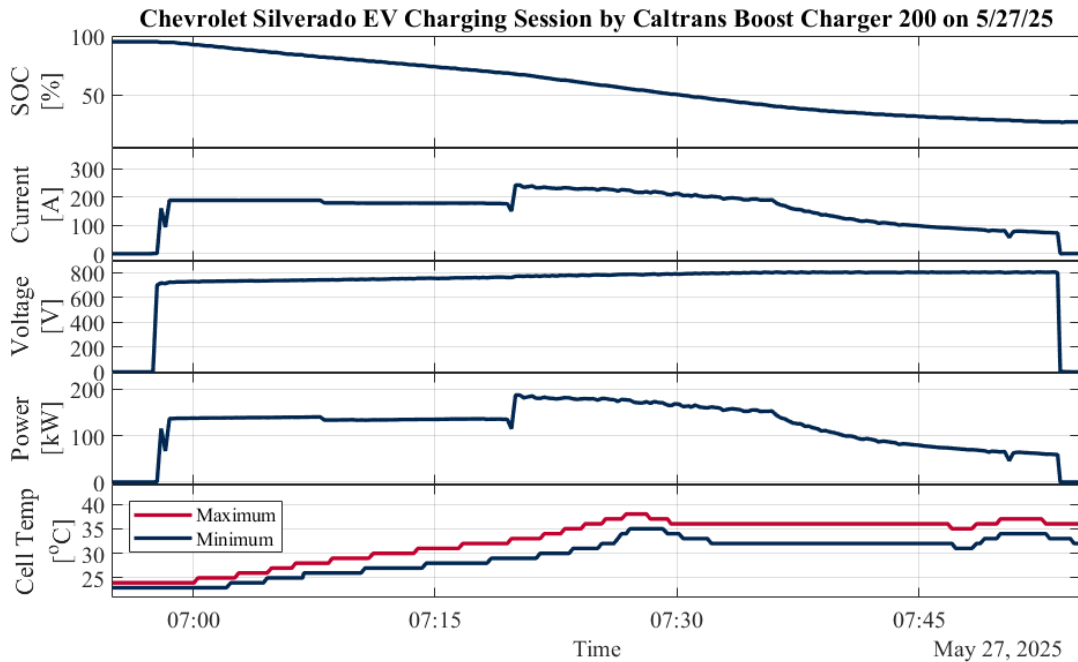
Figure D.1: Boost Charger 200 installed at Caltrans SOC, current, voltage, power, and minimum and maximum cell temperatures while charging the Chevrolet Silverado EV



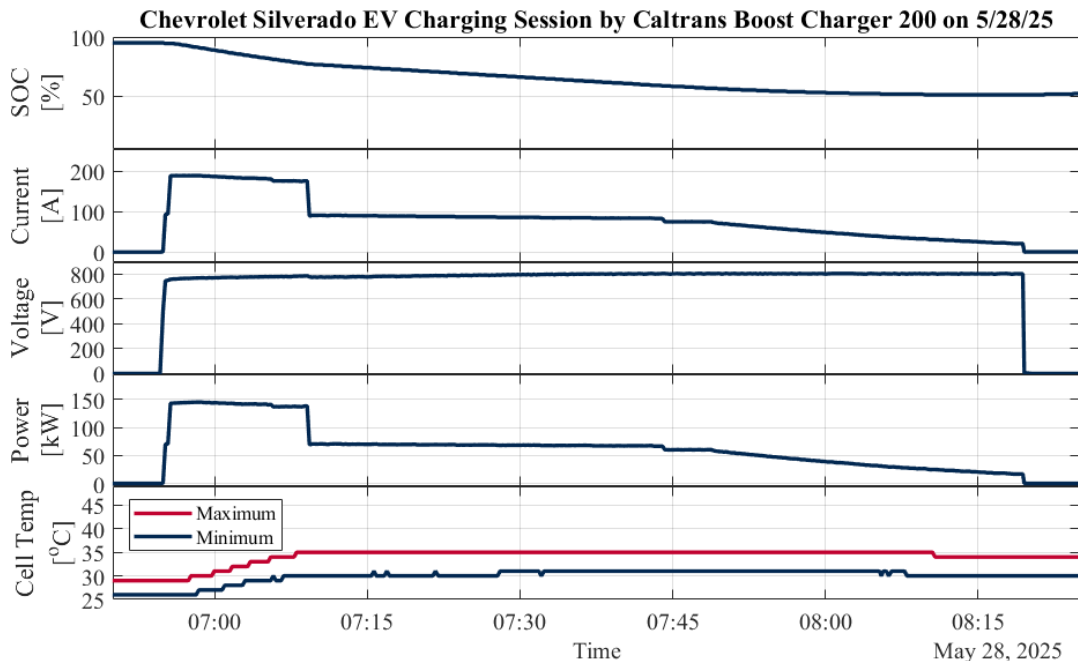
**Figure D.2: FreeWire Boost Charger 200 installed at Caltrans SOC, current, voltage, power, and minimum and maximum cell temperatures while charging the Chevrolet Silverado EV**



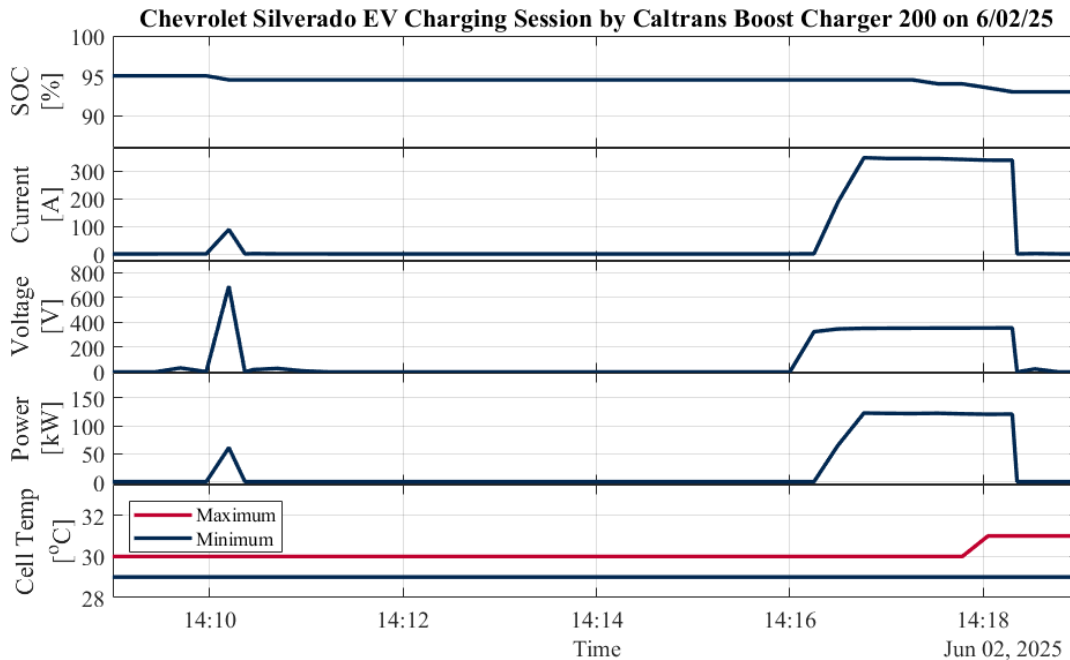
**Figure D.3: FreeWire Boost Charger 200 installed at Caltrans SOC, current, voltage, power, and minimum and maximum cell temperatures while charging the Chevrolet Silverado EV**



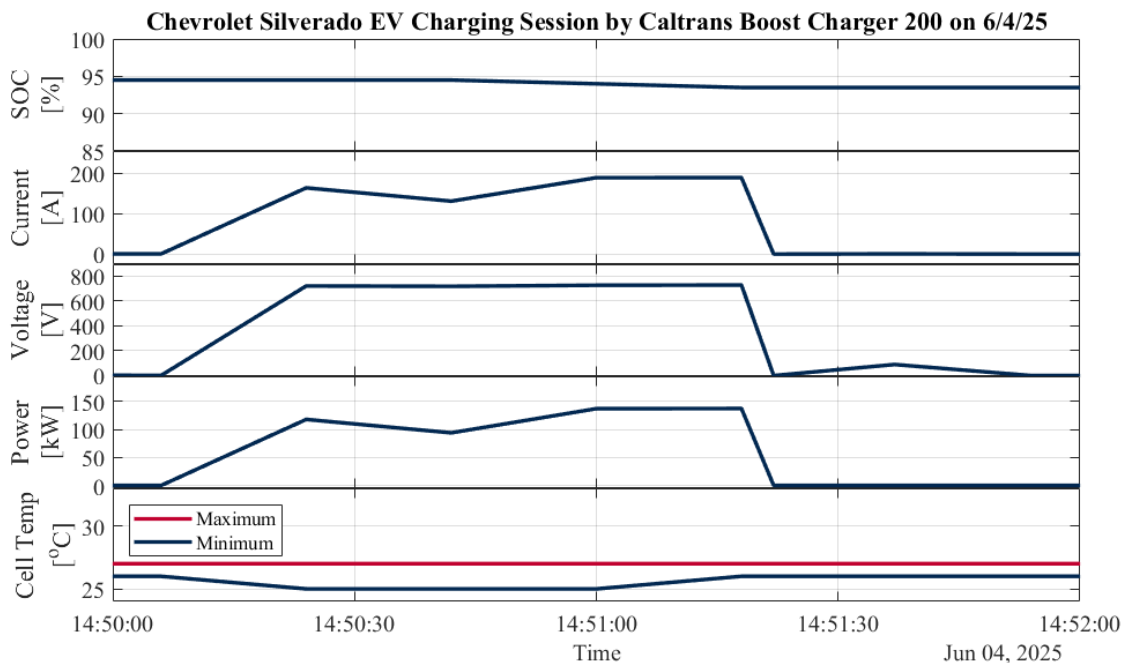
**Figure D.4: FreeWire Boost Charger 200 installed at Caltrans SOC, current, voltage, power, and minimum and maximum cell temperatures while charging the Chevrolet Silverado EV**



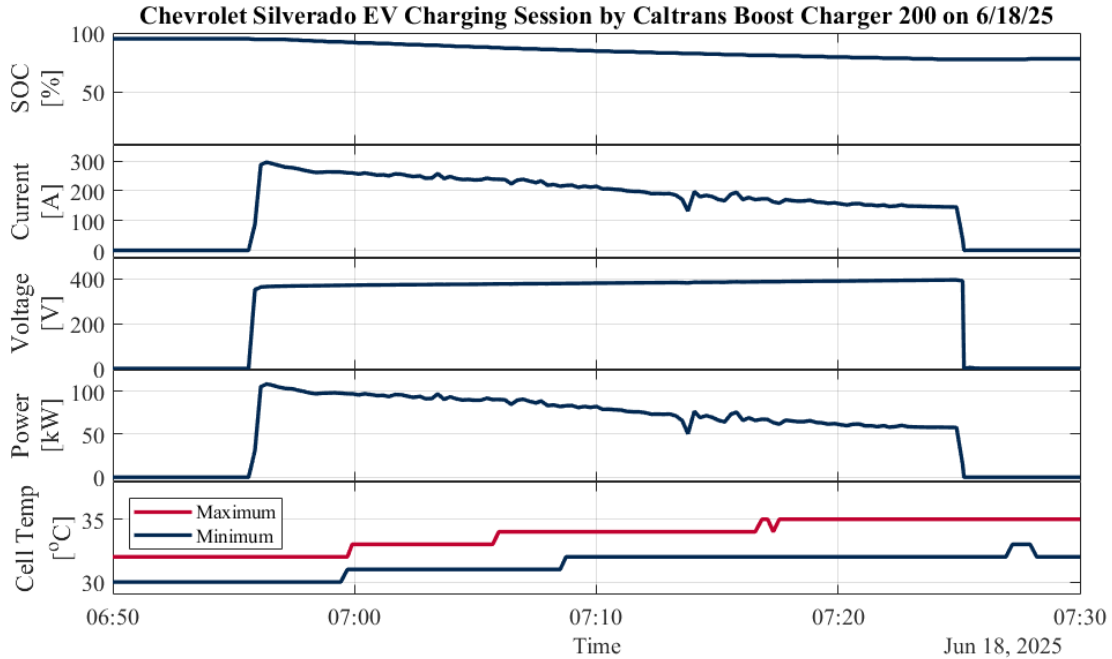
**Figure D.5: FreeWire Boost Charger 200 installed at Caltrans SOC, current, voltage, power, and minimum and maximum cell temperatures while charging the Chevrolet Silverado EV**



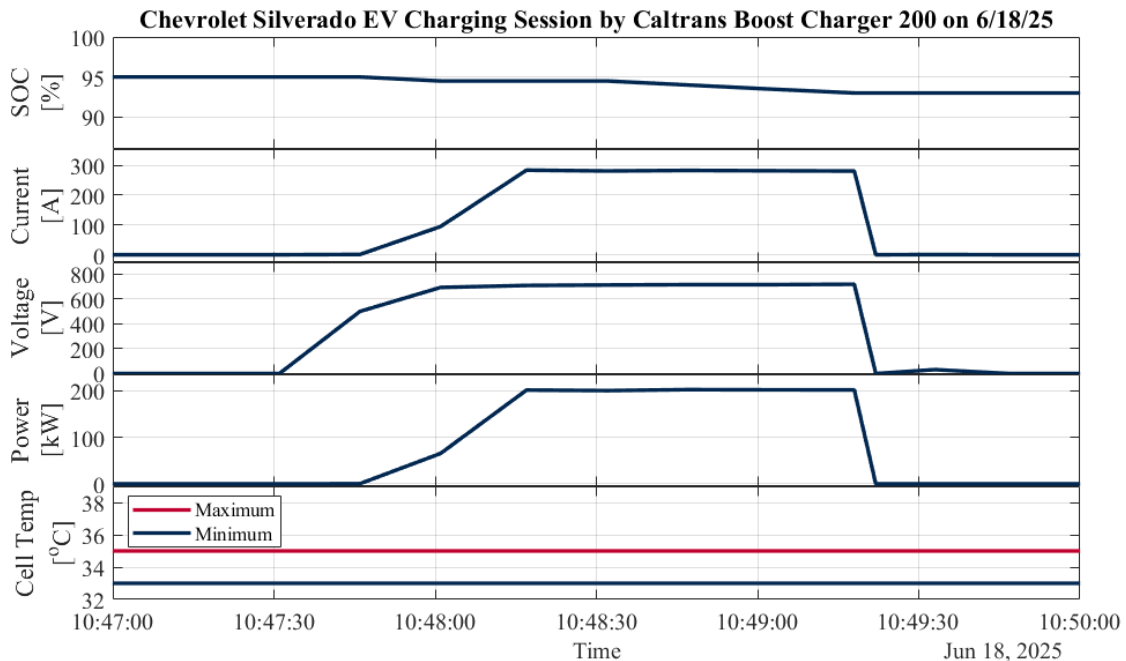
**Figure D.6: FreeWire Boost Charger 200 installed at Caltrans SOC, current, voltage, power, and minimum and maximum cell temperatures while charging the Chevrolet Silverado EV**



**Figure D.7: FreeWire Boost Charger 200 installed at Caltrans SOC, current, voltage, power, and minimum and maximum cell temperatures while charging the Chevrolet Silverado EV**



**Figure D.8: FreeWire Boost Charger 200 installed at Caltrans SOC, current, voltage, power, and minimum and maximum cell temperatures while charging the Chevrolet Silverado EV**



**Figure D.9: FreeWire Boost Charger 200 installed at Caltrans SOC, current, voltage, power, and minimum and maximum cell temperatures while charging the Chevrolet Silverado EV**