

Disclaimer

The contents of this guide reflect the views of the authors who are responsible for the facts and accuracy of the data presented herein. The contents do not necessarily reflect the official views or policies of the State of California or the Federal Highway Administration. This guide does not constitute a standard, specification, or regulation.

CHAPTER 9 MICRO SURFACING

9.1 OVERVIEW

This chapter provides an overview of the micro surfacing products presently used in California, including materials and specifications, mix design, project selection, details regarding construction, a troubleshooting guide to assist the Engineer if problems arise during the placement of these mixtures, and a list of suggested field considerations when placing a micro surfacing. Micro surfacing is very similar to slurry seals in many respects, and as a reader you may be periodically referred to Chapter 8, Slurry Seals to avoid repetition.

9.1.1 General Description

Micro surfacing is a mixture of asphalt emulsion, graded aggregates, mineral filler, water and other chemical additives. The mixture is made and placed on a continuous basis using a Micro Surfacing Machine. The travel paver measures the mix components in a predetermined order into a pug mill. The typical mixing order is aggregate followed by cement, water, the additive and the emulsion. Figure 9-1 shows a schematic for mixing and placing micro surfacing. Micro surfacing requires augers in the spreader box.

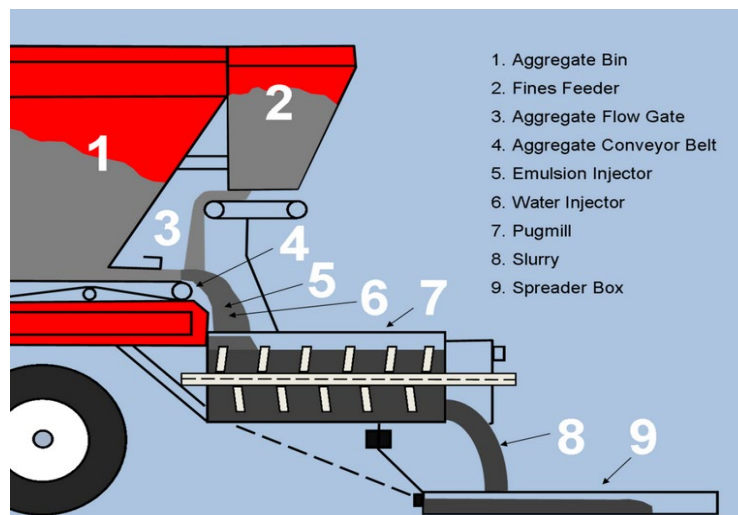

Figure 9-1 Schematic of Micro Surfacing Machine (Roadsaver)

The resulting micro surfacing material is a free-flowing composite material that is spread via a spreader box with augers over the existing road surface. The consistency of the micro surfacing material allows it to be spread over the pavement, wetting it, and forming an adhesive bond to the pavement.

The micro surfacing mixture contains asphalt emulsion that breaks onto the pavement surface through heterogeneous or homogenous flocculation. The asphalt particles coalesce into films, creating a cohesive mixture. The mixture cures, mostly by chemical additives to accelerate the hardening process, the end product is a hardwearing, dense-graded asphalt/aggregate mixture that is bonded to the existing pavement, giving the pavement a new look.

A micro surfacing, does not add any structural capacity to an existing pavement; they are applied as a maintenance treatment to improve the functional characteristics of the pavement surface. The types of slurry surfacing and the pavement characteristics they improve are discussed next.

9.1.2 Types of Slurry Surfacing

There are two main types of slurry surfacing in common use. These include:

- Slurry Seal
- Micro surfacing

Currently, Caltrans uses slurry seals and micro surfacing routinely. Table 9-1 cites the major differences between micro surfacing and slurry seal.

Table 9-1 Slurry Seal vs. Micro Surfacing

Differences In	Micro Surfacing	Slurry Seal
Asphalt Emulsion	Always polymer modified, Quick Set, Micro Surfacing Emulsion (MSE)	Typically, polymer modified in California
Aggregate Quality/Gradation	Stricter specification for Sand Equivalent; uses only Type II or Type III	Can use Type I, II or III
Additives/Bread	Chemical break independent of weather conditions	Breaking and curing is dependent on weather conditions
Curing	May use a chemical filler, e.g. Cement to shorten cure time	Primarily cures through evaporation

Table 9-1 Slurry Seal vs. Micro Surfacing (Continued)

Differences In	Micro Surfacing	Slurry Seal
ADA Requirements	Requires that the project meet ADA requirements. May require re-construction of curbs, gutters, and ramps due to drop offs created by thicker applications of materials.	No modifications to existing facilities are necessary due to a thinner layer of materials being applied.

Micro surfacing is a thin surfacing, which can be placed in two or more lifts, thus being two to three times the thickness of the largest stone in the grading. The emulsion in the system is always polymer modified and special additives are used to create a chemical break that is largely independent of weather conditions. In breaking, the emulsion forces water from the aggregate surface. Such systems can often be opened to traffic within one hour or less after its application under a range of weather conditions (Holleran, 2001a). Figure 9-2 shows two layers of micro surfacing.

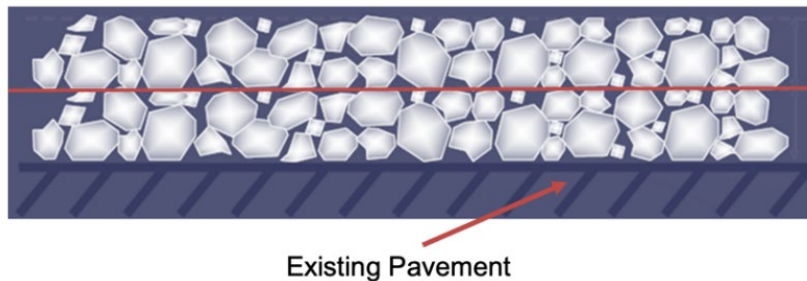

Figure 9-2 Two Layers of Micro Surfacing

Micro surfacing can be used for the same applications as slurry seals. However, micro surfacing uses better quality aggregates and has a faster setting emulsion with higher stiffness, allowing thicker layers to be placed. Usually, micro surfacing costs more, but has benefits over slurry seals.

Recycled Asphalt Pavement (RAP) is also being more commonly used. Currently, the Caltrans Standard Specifications, 2025, do not include recycled aggregate for micro surfacing. If it were included in a current project, a Non-Standard Special Provision (NSSP) would have to be developed, or the Resident Engineer would have to write a Contract Change Order (CCO). This NSSP or CCO must be approved by the Pavement Program.

This stiffer binder creates the following extended performance characteristics for micro surfacing:

- Correction of Minor Surface Profile Irregularities
- Rut Filling
- Higher Durability
- Ability to be Placed at Night or in Cooler Temperatures

Figure 9-3 shows a difference in distress after 7-years at Lake Shore Drive, in Lake Tahoe, California. The slurry seal is showing signs of delaminating, and raveling, while the micro surfacing does not show those distresses.



Figure 9-3 Comparison of Distresses after 7-Years in High Mountain Climate Region

Micro surfacing, like slurry seal, is not intended as a crack treatment and will not prevent cracks in the underlying pavement from reflecting through to the surface. Micro surfacing does not add any structural capacity to an existing pavement; it is applied as a maintenance treatment to improve the functional characteristics of the pavement surface.

9.2 MATERIALS

The main materials used in micro surfacing are:

- Asphalt Emulsion with Polymer Modification
- Water
- Aggregate
- Mineral Filler
- Additives

9.2.1 Asphalt Emulsion

Asphalt emulsions are defined in Chapter 2 of this advisory guide as dispersions of asphalt in water stabilized by a chemical system. In the case of slurry surfacing systems (like slurry seal and micro surfacing), the emulsion may be cationic or anionic; however, cationic emulsions are the most common. Caltrans Standard Specifications Section 94 (Caltrans, 2025) provides specifications for the main emulsion types. However, only polymer-modified (PM), quick-set (QS) emulsions are used in micro surfacing. Common polymer modified quick setting emulsions include:

- PMCQS-1h, not approved by Caltrans for micro surfacing
- PMQS-1h, not approved by Caltrans for micro surfacing
- MSE (Micro surfacing emulsion) (Caltrans, 2025)

For Caltrans Standard Specifications 2025, micro surfacing emulsion must comply with the requirements shown in the following table from Section 94-1.02K, which is MSE: Basic emulsion requirements for MSE are shown in Table 9-2. Key requirements include the binder content and residual properties. The viscosity is of importance as well as the storage stability to ensure that the emulsion can be used effectively in the field.

Table 9-2 Micro Surfacing Emulsion (MSE) Requirements

Quality Characteristic	Test Method	Requirement Grade MSE
Saybolt Furol viscosity, at 25°C (Saybolt Furol seconds)	AASHTO T 59 ^b	15–90
Storage stability test, 1 day (max, %)		1
Sieve test (max, %)		0.30
Particle charge ^a		Positive

^aIf the result of the particle charge test is inconclusive; the asphaltic emulsion must be tested for pH under ASTM E70.

^bDistillation temperature of 350°F

These emulsions are specially formulated for compatibility with the aggregate and must meet the appropriate mix design parameters. The Caltrans Micro surfacing Pilot Study carried out in 2001 was the first step in the process of implementing micro surfacing for Caltrans, and a special provision specification was developed under this study, the current Caltrans Standard Specifications include micro surfacing, and has a Standard Specification for MSE emulsion.

Emulsion specifications are based on standard emulsion characteristics, such as stability, binder content, and viscosity. In all micro surfacing systems, polymer is added to the emulsion, the polymer enhances stone retention, especially in the early life of the treatment. The added polymer allows micro surfacing to be placed in cooler temperatures. Polymers also improve softening point and flexibility, which enhance the treatment’s crack resistance and, in the case of micro surfacing, allow thicker sections (two to three stones thick) to be placed. Thicker sections allow micro surfacing to be used for rut filling. Generally, micro surfacing and slurry seal mixtures with a polymer-modified emulsion do not impart significant resistance to reflective cracking so crack sealing is necessary prior to application to reduce reflective cracking.

Emulsions are usually modified with latex, which is an emulsion of rubber particles. The latex does not mix with the asphalt; rather, the latex and the asphalt particles intermingle to form a 3-D structure, as illustrated in Figure 9-4. Micro surfacing is modified with either natural latex or Styrene-Butadiene Rubber (SBR) latex.

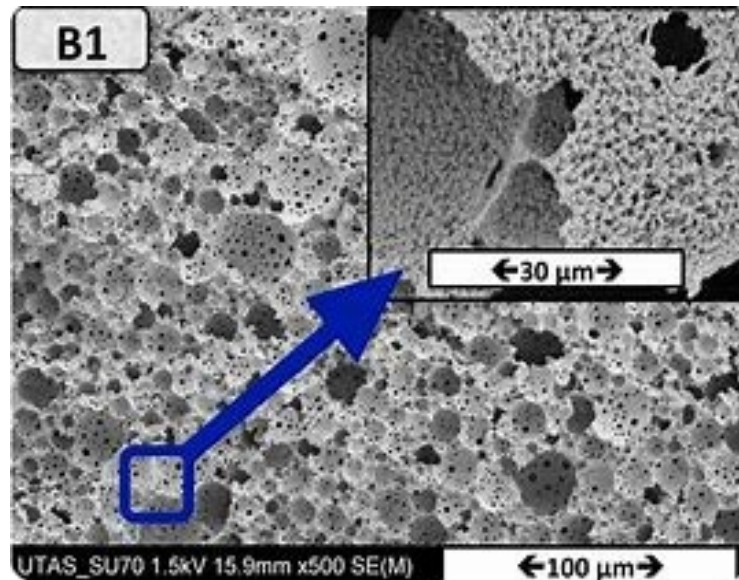

Figure 9-4 Scanning Electron Micrographs of Polymer Emulsion ([Researchgate.net](#))

Latex may separate from the emulsion due to the differences in density. If separation occurs, the latex must be remixed into the emulsion by circulation in the tanker before the modified emulsion is transferred to the slurry machine for application per the Caltrans Standard Specifications, 2025.

9.2.2 Aggregates

The aggregate's key physical characteristics for suitable incorporation into a micro surfacing mix are defined by:

- **Geology:** This determines the aggregate's compatibility with the emulsion along with its adhesive and cohesive properties.
- **Shape:** The aggregates must have 95 percent fractured faces (Caltrans 2025) in order to form the required interlocking matrix. Rounded aggregates will result in poor mix strength.
- **Texture:** Rough surfaces form bonds more easily with emulsions.
- **Age and Reactivity:** Freshly crushed aggregates have a higher surface charge than aged (weathered) aggregates. Surface charge plays a primary role in reaction rates.
- **Cleanness:** Deleterious materials such as clay, dust, or silt can cause poor cohesion and adversely affect reaction rates.
- **Soundness and Abrasion Resistance:** These features play a particularly important role in areas that experience freeze-thaw cycles or are very wet.

Two gradations are specified for micro surfacing; namely, Type II and Type III (Caltrans, 2025). The gradation for each type is listed in Table 9-3. These gradations are similar to those specified in the Greenbook, and ISSA.

Table 9-3 Caltrans Slurry Surfacing Aggregate Gradings (Caltrans, 2025)

Sieve Size	Percentage Passing Type II	Percentage Passing Type III
3/8 in (9.5mm)	100	100
No. 4 (4.75 mm)	94-100	70-90
No. 8 (2.36 mm)	65-90	45-70
No. 16 (1.18 mm)	40-70	28-50
No. 30 (600- μ m)	25-50	19-34
No. 200 (75- μ m)	5-15	5-15

The primary difference among these gradations is the aggregate top size. This dictates the amount of residual asphalt required by the mixture and the purpose to which the micro surfacing is most suited. Type II micro surfacing is finer than Type III and is suggested for urban and residential streets and airport runways. Type III micro surfacing has the coarsest grading and is appropriate for filling minor surface irregularities, correcting raveling and oxidation, and restoring surface friction. Type III micro surfacing is typically used on arterial streets and highways. Micro surfacing may also be used on concrete pavements and bridge decks with varying recommended application rates.

The role of fines (i.e., aggregate particles No. 200 [75 μ m] and finer) in a slurry surfacing mix is to form a mortar with the residual asphalt to cement the larger stones in place. The fines content is essential for creating a cohesive hardwearing mix. Generally, the fines content should be at the mid- point of the grading envelope. Previous work suggests that the distribution of the sub-No. 200 (75 micron) fraction is critical to control the reaction rate in micro surfacing emulsions (Schilling, 2002). The general aggregate quality requirements for the various slurry systems are listed in Table 9-4.

Table 9-4 General Aggregate Properties (Caltrans, 2025)

Test	Micro Surfacing	Test No. (Purpose)
Sand Equivalent (min)	65	CT 217 (Clay Content)
Durability Index (min)	65	CT 229 (Resistance to wet/dry exposure)
Abrasion (LA Rattler) 500rev	35% max	CT 211 (Resistance to traffic)
Crushed Particles	100%	CT 205

9.2.3 Mineral Filler and Additives

In most micro surfacing systems, cement is used as a mixing aid allowing the mixing time to be extended and creating a creamy consistency that is easy to spread. Additionally, hydroxyl ions counteract the emulsifier ions, resulting in a mix that breaks faster with a shorter curing time. Cement is also a fine material and, as such, absorbs water from the emulsion, causing it to break faster after placement. Fine materials, as previously discussed, also promote cohesion of the mixture by forming a mortar with the residual asphalt. Caltrans Standard Specification, 2025, section 37-3.03B(4), “Mineral Fillers” allow Type I, and Type II, Portland cement. to be used. Type II-V also meets the specifications for Type II as a mineral filler for micro surfacing.

Additives other than cement vary and are features of particular systems. They can act as retardants to the reaction with emulsions, either as a prophylactic, slowing the emulsifier’s access to the aggregate surface, or by preferentially reacting with the emulsifier in the system. Additives include emulsifier solutions, aluminum sulfate, aluminum chloride, and borax. Generally, increasing the concentration of an additive slows the breaking and curing times. This is useful when air temperatures increase during the day.

9.3 MIX DESIGN

The performance of a micro surfacing depends on the quality of the materials and how they interact during and after curing. The mix design procedure looks at the various phases of this process, which include:

- **Mixing:** Will the components mix together and form true, free flowing slurry?
- **Breaking and Curing:** Will the emulsion break in a controlled way on the aggregate, coat the aggregate, and form good films on the aggregate? Will the emulsion build up cohesion to a level that will resist abrasion due to traffic?
- **Performance:** Will the micro surfacing resist traffic-induced stresses?

The steps in micro surfacing design include:

- Prescreening of Materials
- Job Mix Design
- Final Testing

9.3.1 At Each Stage, Mixing, Breaking, Curing, and Performance Issues Are Addressed. *Prescreening*

Prescreening involves testing the physical properties of the raw materials. The emulsion type MSE is checked against the specifications (Table 9-2). The aggregate is checked against specifications (Tables 9-3 and 9-4) and a simple mixing test is performed to assess compatibility with the emulsion. When both the emulsion and aggregate are shown to meet the specifications, the job mix formula can be developed. During the mix design process,

the materials may be changed until satisfactory results are obtained.

9.3.2 Job Mix Design

Mixing Proportions

The International Slurry Surfacing Association (ISSA) test method, detailed in Technical Bulletin 102, is no longer used because it was too subjective. The mix design test method is now ISSA TB 113, which refers to A143 (2021) for micro surfacing. A minimum time in seconds is required to ensure that the mixture will be able to mix without breaking in the slurry machine. Also at this stage, the water content and additive content can be determined to produce a quality mixture. Figure 9-5 illustrates a good slurry mixture consistency which meets Caltrans' requirements.



Figure 9-5 Good Mixture Consistency

The mixing time must be at least 120 seconds for micro surfacing at 77°F (25°C). The process may be repeated at elevated or reduced temperatures to simulate expected field conditions at the time of application. The best mix is chosen, based on good coating of mixing times in excess of the minimum required through the entire range of expected application temperatures.

Wet Cohesion

Once the emulsion content is selected, three mixes are then made, one at the selected emulsion percentage from above, one at -2% of the selected emulsion content and one at +2% of the selected emulsion content. This allows a bracketing of the desired mix proportions. The ISSA test method TB 139 (ISSA, 1990) is used to determine the cohesion build-up in a slurry mixture. This test may be performed at the expected field temperatures to provide the most accurate estimate of the treatment's characteristics. Table 9-5 lists mix requirements for micro surfacing.

Table 9-5 Micro Surfacing Mix Design Requirements

Micro Surfacing Mix Design Proportion Limits	
Residual Asphalt	5.5% to 10.5% by dry mass of aggregate (Caltrans)
Mineral Filler	0% to 3% by dry mass of aggregate
Set Additives	As needed
Water	As required to produce proper mix consistency. Contractor shall set target, min., and max. water contents in their mix designs and ensure construction conforms to approved mix designs.

Abrasion Resistance (Wet Track Abrasion Test – WTAT)

Mixes are made at three emulsion contents, optimum, optimum +2%, and -2% of optimum. These mixes are then cured in circular molds for 16 hours at 140°F (60°C). The samples are then soaked for either 1 hour or 6 days, depending on the abrasion test (TB 100) (ISSA, 1990) and the material. Slurry design requires a 1-hour soaking while micro surfacing requires 1-hour and 6-day soaking periods. After soaking, a standard rubber hose is ground over the surface of the sample (while still submerged) for a set period of time. The wear loss is then calculated. The test equipment is shown in Figure 9-6, while the abrasion resistance requirements are listed in Table 9-4.

The results of the abrasion test are plotted along with the specification requirements. This allows selection of the minimum binder content of the mixture.

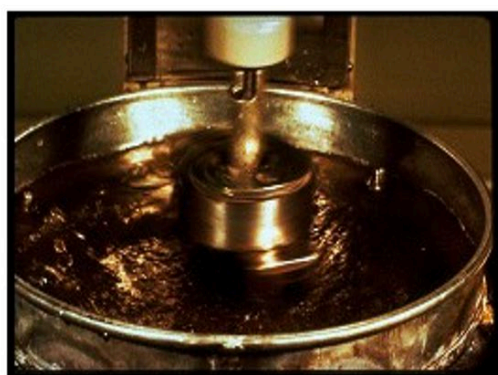

a) Slurry Surfacing Wearing, Tester TB 100 (Cooper Company, 2024) b) Orbital Grinding of Sample Using Rubber Hose Attachment

Figure 9-6 Wet Track Abrasion Test Apparatus and Test in Progress

Micro surfacing mix design requirements are included in the Caltrans Standard Specifications, 2025, in Section 37-3.03B(5). The mix design proportioning limits are included in the table entitled “Micro-surfacing Mix Design Proportion Limits”, and the table entitled “Micro-surfacing Mix Design Requirements”. Table 9-6 shows the ISSA, 2005, requirements as well as the Caltrans, 2025, requirements.

Table 9-6 Micro Surfacing Mix Design Tests (Caltrans, 2025, ISSA, 2005)

Quality Characteristic	ISSA Test Methods	Requirements (Caltrans, 2025)
Wet Cohesion (Min. kg-cm)	TB 139	12 (At 30 minutes set) 20 (At 60 minutes set)
Excess Asphalt	TB 109	540 (Max., g/m ²)
Wet Stripping	TB 114	90
Wet Track Abrasion, Max., g/m ²	TB 100	810 for Caltrans 810 for Greenbook
Displacement	TB 147A	5 (Lateral Max. %)
Class Compatibility (Min. grade points)	TB 144	(AAA, BAA)11
Mix Time at 25° C Min.*	TB 113	Controllable to 120 Seconds

**Mixing test must pass max expected air temp on the site using project materials.*

Upper Binder Limit

The upper binder limit is determined using the Loaded Wheel Test, as described in TB 109 (ISSA, 2018). In this test, the micro surface specimen poured in a mold and allowed to set for 12 hours to a constant weight. The specimen is placed in a loaded rubber-tired reciprocating wheel as illustrated in Figure 9-6. After 1000 loading cycles, the specimen is removed from the machine, washed and dried to constant weight. Then, the specimen is mounted again on the machine and hot sand is added on the surface. After another 100 cycles of compaction, the increase in weight of the specimen due to sand adhesion is noted. This provides a measure of the free asphalt on the surface of the sample. The more prone the mix is to flushing or bleeding under traffic loading the larger the amount of sand retained on the specimen. Figure 9-7 illustrates the test apparatus along with a series of tested samples.

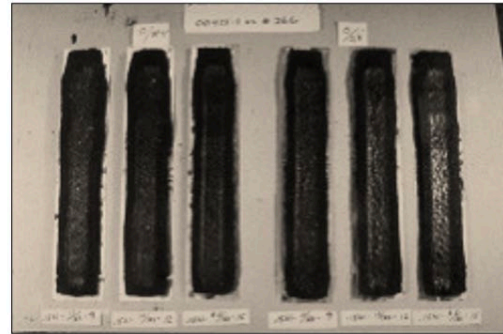
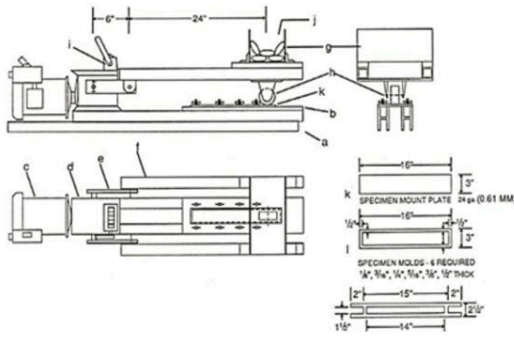

a) Schematic of Loaded Wheel Tester (ISSA TB 109)

b) Tested Samples Showing Retained Sand

Figure 9-7 Loaded Wheel Test for Excess Asphalt Test Apparatus, and Test Samples

Optimum Binder

The optimum percentage emulsion or binder content is found by plotting the results obtained from the Wet Track Test (TB 100) and the Excess Binder Test (TB 109) (ISSA, 2018). Figure 9-8 illustrates a typical plot of test results. The optimum binder content is close to the intersection of the two plotted lines, but the testing does not account for all the factors influencing the mix. For example, the optimum binder content at the intersection of the plotted results is adjusted for the expected traffic conditions. A rule of thumb is to select the highest binder content that passes both tests for low traffic conditions and the lowest binder content for heavy traffic conditions. Note: This test requires an experienced designer to select the optimum and this must be based on field knowledge and experience.

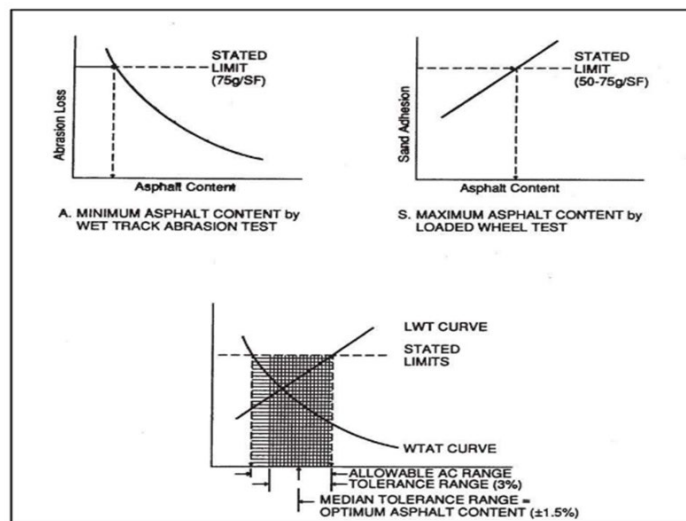

Figure 9-8 Graphical Determination of Optimum Asphalt Content (ISSA TB 800 (2020))

9.3.3 Final Testing

Once the job mix components have been selected, the mix is tested to determine its properties and ensure compliance with the specifications listed in Table 9-6. If the mix conforms to the specifications, the emulsion content and aggregate grading is reported as the job mix formula.

Field adjustments may be made to the job mix formula to accommodate climatic variables during application. As a result of the mix design process, adjustments are limited to the amounts of additives (cement and retardant) and water content required to ensure a good homogeneous mix at the time of application.

9.4 PROJECT SELECTION

9.4.1 Distress and Application Considerations

Micro surfacing may be used for a range of applications, but job selection is critical and often pretreatments such as pothole patching, crack sealing, and dig outs are required. Table 9-7 lists general job selection criteria for micro surfacing treatments and typical application rates.

Table 9-7 Job Selection Criteria

Applications	Aggregate Type II	Aggregate Type III
Void Filling	•	
Wearing Course (AADT) < 100	•	
Wearing Course (AADT) 100 – 1,000	•	•
Wearing Course (AADT) 1,000 – 20,000	•	•
Minor Shape Correction (0.4-0.8 in [10-20mm])		•
Application Rates in pounds of dry aggregate per square yard	10 – 20	20 – 32

The main use of micro surfacing materials is for pavement preservation as a part of a program of periodic preventative maintenance surface treatments before distresses appear. The main criteria for project selection are:

- Sound and well drained bases, surfaces, and shoulders.
- Free of distresses, including potholes and cracking. These must be repaired before slurry application. Potholes should be filled and compacted several

weeks prior to micro surfacing. Emulsion crack filling should be done several months prior to micro surfacing.

Distress modes that can be addressed using micro surfacing include:

- **Raveling:** Loose surfaces or surfaces losing aggregate may be resurfaced using slurry seals or micro surfacing.
- **Oxidized pavement with hairline cracks:** These surfaces may be resurfaced using slurry seals or micro surfacing.
- **Rutted pavements:** Deformation resulting from consolidation of the surfacing only. Rutting due to base failure or significant plastic deformation of the HMA cannot be treated using micro surfacing except as a temporary measure.
- **Rough pavements with short wavelength:** These irregularities may be treated with micro surfacing, provided the frequency of the irregularities is shorter than the spreader box width.

Distress modes that cannot be addressed using micro surfacing include:

- **Cracking** (including reflection cracking)
- **Base** Failures of any kind
- **HMA** Layers that **exhibit** plastic shear deformation

Micro surfacing will not alleviate the cause of these distresses. As a result, the distresses will continue to form despite the application of a slurry surfacing.

9.4.2 Performance of Micro surfacing

Micro surfacing performance is strongly affected by workmanship and the condition of the pavement at the time of application. When used as a preventive maintenance treatment, on pavements in relatively good condition, micro surfacing may last 7 to 10 years (Van Kirk, 2000), although longer lifetimes have been claimed (Van Kirk, 2000). On average, however, the life expectancy of a micro surfacing treatment is 5 to 7 years. When applied in ruts, the life of the treatment is dependent on the stability of the micro surfacing, the traffic level, and the condition of the underlying pavement.

The main mechanism of failure is wear. Through wear the surface oxidizes and is abraded over time. Premature treatment failure occurs from placement on highly deflecting surfaces, cracked surfaces, pavements with base failures, and on dirty or poorly prepared surfaces (resulting in delamination).

9.5 CONSTRUCTION

The main components of the construction process include:

- Safety and Traffic Control
- Equipment Requirements

- Stockpile/Project Staging Area Requirements
- Surface Preparation
- Equipment Calibration
- Test Strips
- Application Conditions
- Types of Applications
- Quality Issues
- Post Construction Conditions
- Post-Treatments

Sections 9.6.2 titled “Field Considerations”, provides a series of tables to guide project personnel through the important aspects of applying micro surfacing.

9.5.1 Traffic Control and Safety

Traffic control must be in place before workforces and equipment arrive in the work zone. Traffic control is required both for the safety of the traveling public and the personnel performing the work. Traffic control includes construction signs, construction cones and/or barricades, flag personnel, and pilot cars to direct traffic, around the construction operation. For detailed traffic control requirements, refer to the Caltrans project specifications and the Caltrans Code of Safe Operating Practices (2022). It is recommended that the public is informed of the pavement maintenance activities that will take place in their neighborhood and that it is very important not to drive on the new surface for as long as the traffic signs are present. Very often drivers assume that the micro surfacing is drivable despite the warning signs and cause damage to the fresh placed treatment. Doorknob cards or fliers are recommended to notify the residents and provide information on how to accommodate the construction activities.

Traffic control is also required to protect the integrity of the application. The curing time for the micro surfacing material will vary depending on the pavement surface conditions and the weather conditions at the time of application as well as chemical additives that may control set time. Under ideal conditions, including increasing air and surface temperatures, it is suggested that traffic be kept off the micro surfacing material until it is adequately cured. Caltrans Standard Plans, 2023, has several plans for traffic control for various highway configurations. See Temporary Traffic Control Systems, T-9 through T-22 of the Standard Plans, and Chapter 8, Field Considerations of the manual.

All employees are advised to wear and use the safety gear required for the micro surfacing operation. This includes, but is not limited to, items such as hard hats, approved Caltrans shirts, safety vests, earplugs, gloves, and safety glasses. See Chapter 2 of the Caltrans Construction Manual, dated June 2023, for construction requirements and personnel duties.

9.5.2 Equipment Requirements

Equipment requirements for micro surfacing machines are covered in Caltrans Standard

Specifications 2025, Section 37. Calibration requirements are discussed in the Material Plant Quality Program (MPQP). Equipment, as shown in Figure 9-9, can be used to place either micro surfacing or slurry seal. As noted earlier in this chapter, the spreader box must include augers for micro surfacing due to it being a stiffer mix. This box is attached to the rear of the paver, allowing a preset thickness of material to be placed. A micro surfacing spreader box is shown in Figure 9-9.



a) Micro Surfacing Machine (Schafer)

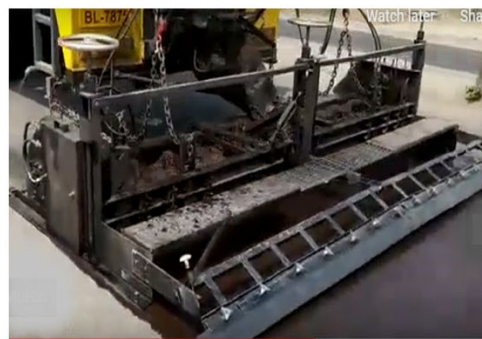

b) Micro Surfacing Screed

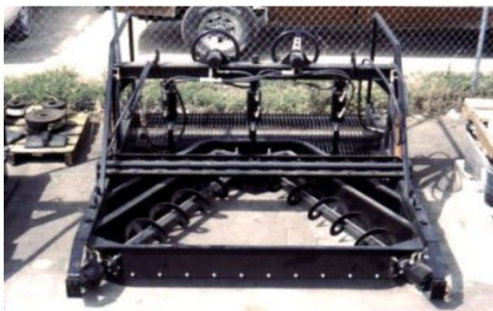

c) Micro Surfacing Rut Filling Machine (CP2 Center)



d) Mounted Outrigger

Figure 9-9 Micro Surfacing Equipment and Application

Rut Filling and Shoulder Equipment

Special boxes are used for rut filling applications when filling ruts greater than 0.5 in (12 mm) deep. When filling ruts less than 0.5 in (12 mm) deep, a steel strike-off box is used for the scratch courses (see Section below). Adjustable width edge boxes are used for shoulders and to create clean joints between shoulders and the traveled way. Figures 9-10 and 9-11 illustrate a rut filling box and an adjustable edge box, respectively.



Figure 9-10 Rut Box (Bergkamp)



Figure 9-11 Adjustable Micro Surfacing Box (VSS)

Equipment Calibration

The design mix is proportioned by weight while the micro surfacing machines deliver materials by volume. Due to this different nature of the measurements, it is essential that calibration be done with the actual job materials. No machine should be allowed to work on a Caltrans job without a proper calibration. Equipment requirements for slurry machines are covered in Caltrans Standard Specifications Section 37 (Caltrans, 2025). Calibration requirements are discussed in the Material Plant Quality Program (MPQP).

Caltrans Material Plant Quality Program (MPQP) has calibration procedures in the MPQP Manual (2022) for many different types of plants and slurry pavers. The staff performing the calibration must also be certified to perform the work. Often, the calibration is performed with the County Weights and Measures personnel present along with the District Weights and Measures Coordinator. With equipment computerization, the calibration procedures have changed, and several of the micro surfacing equipment manufacturers have developed new calibration procedures for their new computerized equipment.

Test Strips

The requirements are shown in the Caltrans Standard Specifications, 2025, in section 37-

3.03C(4) Test Strips for micro surfacing. Inspect the test strip after traffic has been on it for 12 hours to determine if the placement procedure is acceptable. The test strip should be from 300 to 450 feet in length. The location of the test strip should be determined at the pre-construction meeting with the contractor.

9.5.3 Stockpile / Project Staging Area Requirements

The stockpile and project staging area must meet some basic requirements. These requirements include:

- A Clean, Well-drained Pad for Aggregate Piles
- Front-end Loader for Loading Machines
- Flow Boy-type Vehicles in Continuous Operation
- A Salt-Free Water Supply
- An Emulsion Tanker
- An Additive Tanker

The stockpile and staging area should be as close as possible to the job site. Figure 9-12 illustrates a typical stockpile and staging area.



Figure 9-12 A Typical Project Staging Area (SlideServe)

Operations should be scheduled to run as smoothly as possible and provide good traffic flow through the work zone. Aggregates that are measured to have moisture content below optimum should be remixed using the front-end loader to avoid segregation. In some cases, aggregates that are separating in the stockpile or during loading may need to be sprayed with water to avoid fines loss.

9.5.4 Surface Preparation

The main objective of surface preparation is to provide a clean and sound surface on which the micro surfacing is applied. The first step of surface preparation is to restore the pavement's structural integrity and functional performance characteristics through crack

sealing and patching (Chapters 4 and 5).

Immediately before the micro surfacing is applied, the road must be swept clean. If clay or hard-to-remove materials (such as organic matter, agricultural residue, etc.) are present, high power pressure washing may be required. If left on the road, these types of contaminants will cause delamination of the treatment in these areas. Thermoplastic road markings must also be removed prior to placing micro surfacing, to an 85 percent level of removal. Paint markings require no pretreatment. Crack sealant should not be “banded” but struck off at the pavement surface.

Utility inlets should be covered with heavy paper or roofing felt taped or glued to the surface of the inlet. A temporary marker should be placed on the manholes and other utility facilities to identify their locations. The paper is removed once the slurry surfacing has sufficiently cured. In addition to covering the inlets, all starts, stops, and handwork on turnouts should be done on roofing felt to ensure sharp, uniform joints and edges. Figure 9-13 illustrates the various surface preparation steps along with illustrations of delamination resulting from poor surface preparation.



a) Sweeping

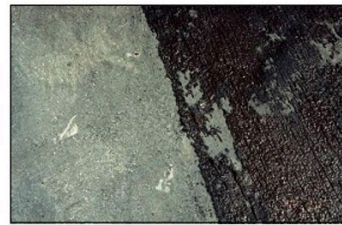

b) Dirty Surfaces Result in Poor Adhesion (Delamination)



c) Cover Utilities with Kraft Paper



d) Micro Surfacing Covers Inlet and Paper Cover



e) Peel Off Paper Covering Once Treatment has Cured

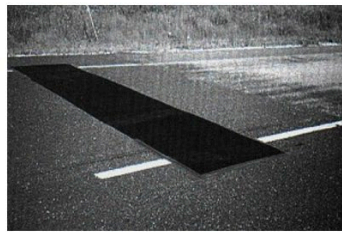

f) Starting Transverse Joints on Roofing Felt Produces Clean Joints

Figure 9-13 Surface Preparation Methods

9.5.5 Application Conditions

The application conditions required are addressed in detail in the Caltrans “Micro surfacing Pilot Study 2001”, Appendix A (Caltrans, 2002). The basic requirement for success is that the emulsion must be able to break and form continuous films, as it is the only way a slurry mixture can become cohesive. As a result, humidity, wind conditions, air and surface temperature are important and need to be considered. Modifications to additives should be made according to the changing environment during application. Because micro surfacing slurry systems use a chemical break, they can be placed at night.

Micro surfacing shall only be placed when the ambient temperature is 8°C (46°F) and rising and the high temperature for the day is expected to be at least 20°C. Micro surfacing shall not be placed if rain is imminent or if the ambient temperature is expected to fall below 2°C within 24 hours after placement. Micro surfacing systems will typically resist rain induced damage after as little as one hour but typically require at least three hours to cure to a fully waterproof state. Additionally, breaking time for a micro surfacing system is affected by ambient temperature. Figure 9-14 shows the effect of temperature on the breaking rate of emulsion.

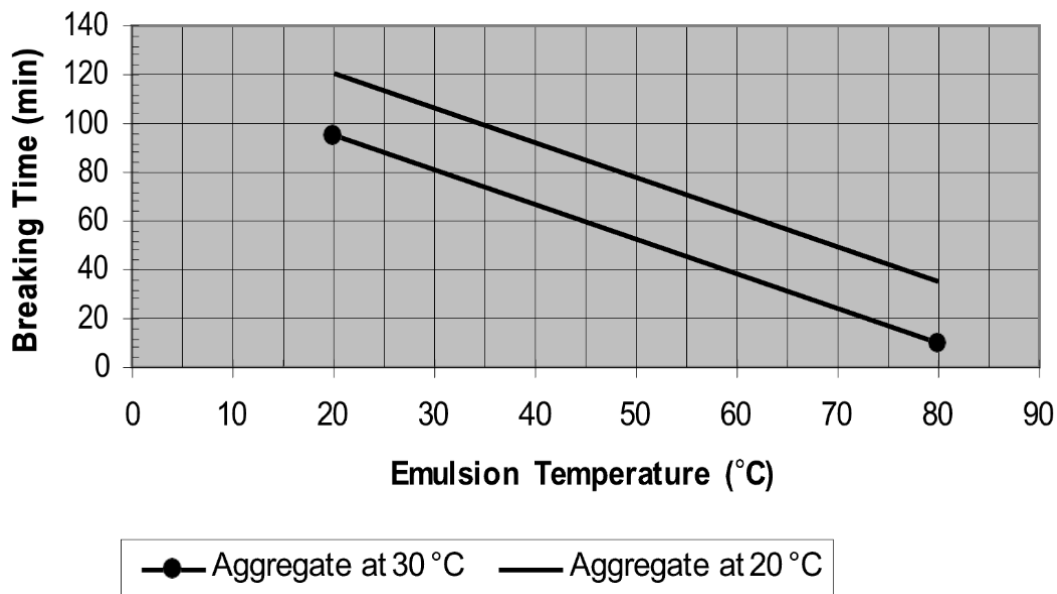

Figure 9-14 Effect of Temperature on Break Rate

9.5.6 Types of Applications

Full Width Seal

When applying a full width seal a standard spreader box is used. Three passes are typically used for a two-lane roadway. This allows clean edges and minimizes overlaps (usually 3 in (75 mm)). Overlapped seals should only be used when the pavement being sealed is level and in sound condition.

Scratch Coat

Scratch coats are used to level pavements with minor transverse irregularities that are narrower than the width of the spreader box, or on pavements with longitudinal ruts less than 0.5 in (12.5 mm) deep.

When applying a scratch coat, a steel strike-off is substituted for the secondary strike-off in the standard micro surfacing drag box. The steel strike-off drags over the high spots of the pavement, filling in the irregularities. Such materials are highly friable and stone loss is often high. Scratch coats should always be covered with a surface seal. The scratch coat principle along with a photo of a finished section is illustrated in Figure 9-15.

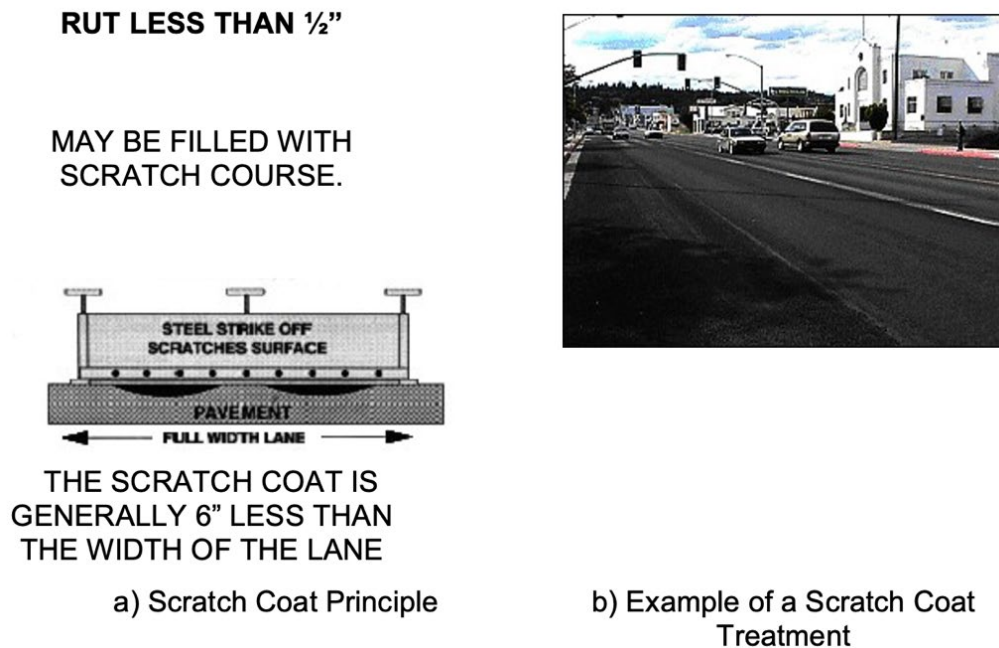

Figure 9-15 Scratch Coat Principles and Treatment

Rut Filling

Ruts may be filled with a high stability micro surfacing mix. A rut box is essential for this application; it channels mix into the ruts and leaves a crowned finish to compensate for post compaction due to trafficking. Generally, ruts filled in this manner are covered with a surface seal, but this is not essential. Rolling is often incorporated to ensure compaction of the mix placed in rutted surfaces. Figure 9-16 illustrates the principle behind rut filling and provides a cross-sectional diagram of a filled rut. Rut filling should only be used on stable ruts that have resulted from long-term traffic compaction. If rutting is ongoing, the micro surfacing will not prevent its continued development. Figure 9-17 illustrates both suitable and unsuitable candidates for rut filling.

**REPROFILING
 RUTTED WHEELS
 WITH**

MICRO-SURFACING

For each inch of applied micro-surface mix
 add 1/8" to 1/4" crown to each rut fill

to compensate for return traffic compaction.

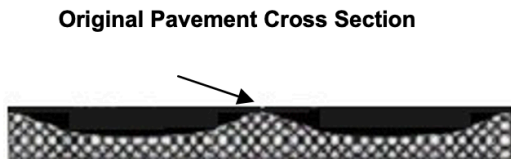

Ruts in Wheel paths

Cross Section of a Rut

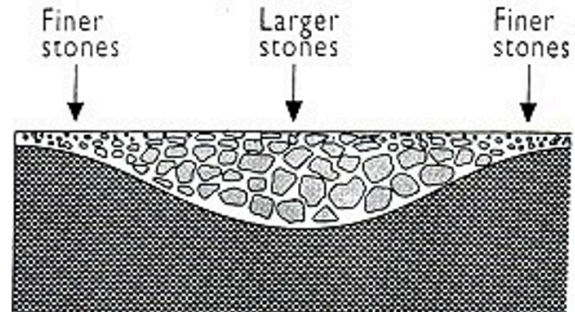

RUTS 1/2" & OVER MUST USE THE RUT BOX

a) Principle of Rut Filling (Holleran, 2002)

b) Cross Section of a Filled Rut (Holleran, 2001)

Figure 9-16 Rut Filling Principle and Sectional Diagram

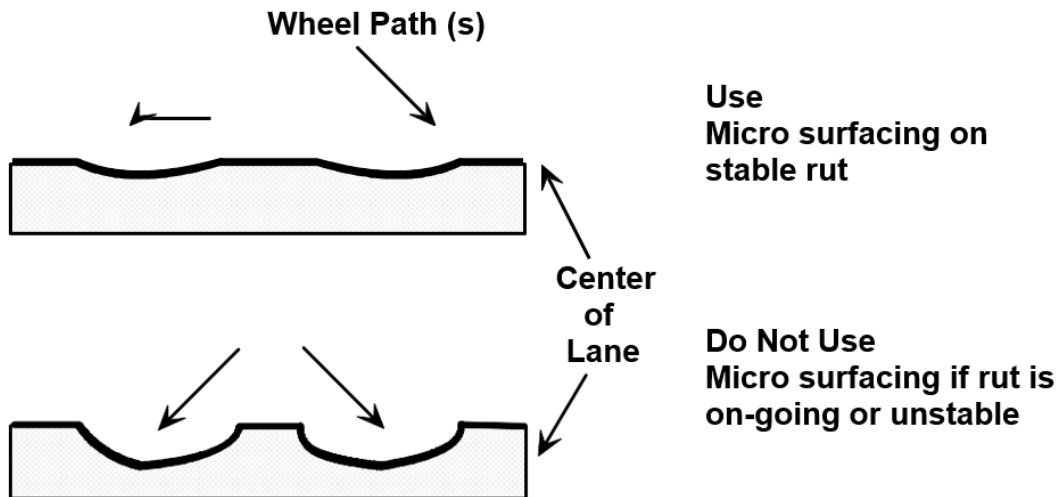

Figure 9-17 Suitable and Unsuitable Surfaces to Use Micro Surfacing as a Rut Filler

9.5.7 Quality Issues

Quality control is critical during the construction process to achieve a uniform surface finish. The main areas of concern are discussed below.

Longitudinal Joints

Longitudinal joints may be overlapped or butt jointed. They should be straight or curve with the traffic lane. Overlaps should not be in the wheel paths and should not exceed 3 in (75 mm) in width. Figure 9-18 illustrates high-quality and poor-quality longitudinal joints.



a) High Quality Longitudinal Joint

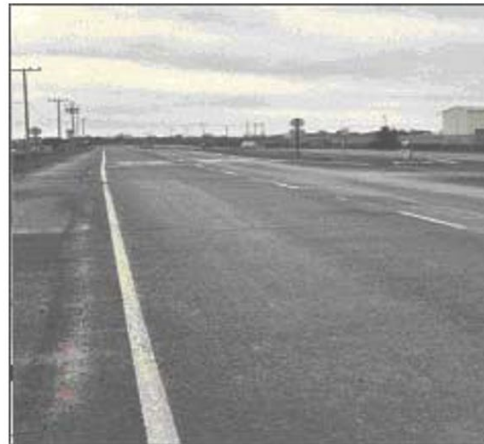

b) Poor Quality Longitudinal Joints

Figure 9-18 Longitudinal Joints

Transverse Joints

Transverse joints are inevitable when working with batch systems; every time a truck is emptied a transverse joint is required. Transitions at these joints must be smooth to avoid creating a bump in the surface. The joints must be butted to avoid these bumps, and handwork should be kept to a minimum. The main difficulty in obtaining a smooth joint occurs as the slurry machine starts up at the joint, particularly when working with micro surfacing that is difficult to work by hand and breaks quickly. Some contractors tend to over wet (add too much water) to the mix at start-ups. This leads to poor texture and scarring at the joints. Starting transverse joints on roofing felt can eliminate these problems. Figure 9-19 illustrates high-quality and poor-quality transverse joints.



a) High-Quality Transverse Joint



b) Poor-Quality Transverse Joint

Figure 9-19 Transverse Joints

Edges and Shoulders

Micro surfaced edges and shoulders can be rough and look poor. This occurs more often with micro surfacing applications, which break quickly, making them harder to work by hand than slurry seals. For micro surfacing, handwork should be kept to a minimum. The edge of the spreader box should be outside the line of the pavement and edge boxes should be used when shoulders are covered. Figure 9-20 illustrates high quality and poor-quality edge and handwork.



a) High-Quality Edges and Shoulder



b) Poor-Quality Edges and Shoulder

Figure 9-20 Edges and Shoulders joints

Uneven Mixes and Segregation

Poorly designed micro surfacing mixtures or mixtures with low cement content or too high a water content may separate once mixing in the box has ceased. This leads to a black and flush looking surface with poor texture. Separated mixes may lead to a “false slurry” where the emulsion breaks onto the fine material. In such instances delamination may occur, resulting in premature failure. These types of mixes can be recognized as non-

uniform mixes that appear to be setting very slowly. Figure 9-21 illustrates segregation and delamination resulting from a false slurry.



a) Segregation



b) Delamination from a False Slurry

Figure 9-21 Poor Mixes Lead with: a) Segregation and b) Delamination

Smoothness Problems

Micro surfacing systems follow the existing road surface profile and thus do not have the ability to significantly change the pavement's smoothness. However, when using stiffer mixes, the spreader box may, if incorrectly set up, chatter or bump as the material is spread and produce a washboard effect. The chattering may be addressed by making the mixture slower to set, adjusting the rubbers on the box, or adding weight to the back of the spreader box. Figure 9-22 illustrates the wash-boarding effect.



Figure 9-22 Wash-boarding Effect

Damage Caused by Premature Reopening to Traffic

The micro surfacing must build sufficient cohesion to resist abrasion due to traffic. Early stone shedding is normal but should not exceed 3%. If a mixture is reopened to traffic too early it will ravel off quickly, particularly in high stress areas. It is important that the mixture has formed adequate cohesion before it is opened to traffic. Choosing the right time to reopen a surface to traffic is based largely on experience. However, a general rule of thumb for a slurry seal is that it can be opened when it has turned black; a micro surfacing can carry traffic when it is expelling clear water and hardens with chemical additives to control the curing time. Figure 9-23 illustrates raveling caused by premature opening to traffic.



Figure 9-23 Traffic Damage Caused by Early Trafficking

9.5.8 Post Construction Conditions

Emulsion systems do not lose all water in the first hours after placement; the total water loss process can take up to several weeks. During this period the surface will be water resistant; however, if the water freezes, it can cause rupture of the binder film and subsequent raveling. For this reason, projects should not be started without a 2-week window when freezing weather will not occur.

Asphalt emulsion-based systems cannot re-emulsify; however, if not fully cured, these systems can be tender enough to re-disperse under the effects of traffic loading and excessive water, especially ponding water. In this process, broken aggregates or asphalt particles that have not fully coalesced into films are dispersed in water, which disintegrate the emulsion. Thus, while light rain 3 hours after placing a micro surfacing is acceptable, heavy rain coupled with heavy traffic will likely lead to surface damage, especially in high shear (e.g., turning movement) areas. Figure 9-24 illustrates damage caused by heavy rain in a high shear location.



Figure 9-24 Damage Due to Post Application Heavy Rain with Shear

9.5.9 Post-Treatments

Rolling

Micro surfacing will lose stone until the surface voids have been closed off, but it is acceptable for approximately 3% of surface stone to be lost. To limit the amount of loss, rolling with pneumatic rollers may be incorporated. For rut filling applications, rolling is almost always recommended. The roller should be light (6-7 tons maximum) and non-ballasted. One to two passes at a slow speed are recommended. This allows the water to be pressed to the surface, promoting evaporation and curing. Larger stones will be properly embedded, reducing shedding or early raveling. Figure 9-25 illustrates a typical roller operation.



Figure 9-25 Rolling a Micro Surfacing

Rolling is always used on airport taxiways due to the low traffic and the seriousness of shedding aggregates in areas where jet engines operate. Figure 9-26 illustrates the rolling of an airport taxiway.



Figure 9-26 Rolling of Micro Surfacing on Airport Taxiways

Sweeping

On heavily trafficked roads, where opening has led to excessive stone loss, sweeping is essential. A self-contained sweeper is the best type of sweeper to use. Sweeping should be done just prior to opening to traffic and at periods determined by the level of stone loss. Figure 9-27 illustrates a self-contained sweeper.



Figure 9-27 Sweeping with a Self-contained Sweeper

Sanding

Sanding may be used to reduce the times that cross streets or intersections are closed. Sanding is the application of a fine layer of dry, washed sand that is broadcast over the slurry surface. Sanding may also be used on wet spots. Sanding should not be done until the slurry can withstand walking traffic. Figure 9-28 illustrates the use of sanding at a cross street.



Figure 9-28 Sanding at a Cross Street

9.6 TROUBLESHOOTING AND FIELD CONSIDERATIONS

9.6.1 Troubleshooting Guide

This section provides information to assist the maintenance personnel in troubleshooting problems with micro surfacing along with “dos and don’ts” that address common problems that may be encountered during the project. The troubleshooting guide presented in Table 9-8 associates common problems to their potential causes. For example, an unstable emulsion, too little water in the mix, incompatibility between the emulsion and the aggregate, may cause a slurry surfacing, such as a micro surfacing to delaminate.

Table 9-8 Trouble Shooting Micro Surfacing Seal Job Problems

Cause	Brown	Whitish	Wont set	Poor Coating	Delayed Opening to Traffic	Breaks In Box	Ravels	Flushes	Delamination	Segregation
Emulsion Unstable				<input type="checkbox"/>		<input type="checkbox"/>			<input type="checkbox"/>	
Emulsion too Stable	<input type="checkbox"/>		<input type="checkbox"/>		<input type="checkbox"/>		<input type="checkbox"/>			
Emulsion too hot						<input type="checkbox"/>				
Too Little Emulsion	<input type="checkbox"/>			<input type="checkbox"/>			<input type="checkbox"/>			
Too Much Emulsion								<input type="checkbox"/>		
Mix too Many Fines				<input type="checkbox"/>		<input type="checkbox"/>	<input type="checkbox"/>			
Mix too much cement		<input type="checkbox"/>				<input type="checkbox"/>				
Mix too little cement			<input type="checkbox"/>		<input type="checkbox"/>		<input type="checkbox"/>			<input type="checkbox"/>
Mix too little additive				<input type="checkbox"/>		<input type="checkbox"/>	<input type="checkbox"/>			
Mix too much additive		<input type="checkbox"/>	<input type="checkbox"/>		<input type="checkbox"/>		<input type="checkbox"/>			
Mix too much water	<input type="checkbox"/>		<input type="checkbox"/>		<input type="checkbox"/>		<input type="checkbox"/>	<input type="checkbox"/>		<input type="checkbox"/>
Mix too little water		<input type="checkbox"/>		<input type="checkbox"/>		<input type="checkbox"/>	<input type="checkbox"/>		<input type="checkbox"/>	
Mix aggregate/emulsion not compatible			<input type="checkbox"/>	<input type="checkbox"/>	<input type="checkbox"/>		<input type="checkbox"/>		<input type="checkbox"/>	<input type="checkbox"/>
Too hot	<input type="checkbox"/>			<input type="checkbox"/>		<input type="checkbox"/>	<input type="checkbox"/>	<input type="checkbox"/>		
Too cold			<input type="checkbox"/>		<input type="checkbox"/>		<input type="checkbox"/>		<input type="checkbox"/>	
Rain	<input type="checkbox"/>		<input type="checkbox"/>	<input type="checkbox"/>	<input type="checkbox"/>		<input type="checkbox"/>	<input type="checkbox"/>	<input type="checkbox"/>	
High humidity		<input type="checkbox"/>	<input type="checkbox"/>							
Surface Fatty			<input type="checkbox"/>					<input type="checkbox"/>		

In addition to the troubleshooting guide, Table 9-9 lists some commonly encountered problems and their recommended solutions.

Table 9-9 Common Problems and Related Solutions

Problem	Solution
Uneven Surface Wash Boarding	<ul style="list-style-type: none"> • Ensure the spreader box is correctly set up. • Ensure the viscosity of the mix is not too high. • Adjust so that the mix does not break too fast. • Wait until the ambient temperature is lower. • Use water sprays on the front of the spreader.
Poor Joints	<ul style="list-style-type: none"> • Reduce the amount of water at start up. • Use water spray if runners of spreader box are running on fresh micro surfacing.
Excessive Ravel	<ul style="list-style-type: none"> • Add cement and reduce additive so that the mix breaks and cures faster. • Check aggregate to ensure the clay fines are not too high. • Control traffic longer and at low speeds. • Wait until fully cured before allowing traffic. • Wait until mix is properly set before brooming or opening to traffic.

9.6.2 Field Considerations

The following tables are guides to the important aspects of performing a micro surfacing project. The tables list items that should be considered in order to promote a successful job outcome. The answers to these questions should be determined, as required, before, during, and after construction. The appropriate staff to do this will vary by job type and size. Some topics may need attention from several staff members. The field supervisor should be acquainted with its contents.

The intention of the table is not to form a report but to bring attention to important aspects and components of the slurry surfacing project process. Some information is product specific and contained in the relevant standard specifications, special standard provisions, or special provisions.

Table 9-10 Field Considerations

Preliminary Responsibilities	
Project Review	<ul style="list-style-type: none"> • Is the project a good candidate for micro surfacing? • Should a micro surfacing seal be used? • What is the depth and extent of any rutting? • How much and what type of cracking exists? • Is crack sealing needed? • How much bleeding or flushing exists? • Is the pavement raveling? • What is the traffic level? • Is the base sound and well drained? • Have the project bid/plan quantities been reviewed?
Document Review	<ul style="list-style-type: none"> • Bid specifications • Mix design information • Special provisions • Construction manual • Traffic control plan (TCP) • Material safety data sheet
Materials Checks	<ul style="list-style-type: none"> • Has a full mix design and compatibility test been completed? • Is the binder from an approved source (if required)? • Has the binder been sampled and submitted for testing? • Does the aggregate meet all specifications? • Is the aggregate clean and free of deleterious materials? • Is the aggregate dry? • Is the emulsion temperature within application temperature specifications?

Table 9-10 Field Considerations (Continued)

Pre-Seal Inspection Responsibilities	
Surface Preparation	<ul style="list-style-type: none"> • Is the surface clean and dry? • Have all pavement distresses been repaired? • Has the existing surface has been inspected for drainage problems?
Equipment Inspection Considerations	
Broom	<ul style="list-style-type: none"> • Are the bristles the proper length? • Can the broom be adjusted vertically to avoid excess pressure?
Calibration of Equipment	<ul style="list-style-type: none"> • Has each machine been calibrated with the project’s aggregate and emulsion? • Who carried out calibration and what documentation has been provided?
Micro Surfacing Machine	<ul style="list-style-type: none"> • Is the machine fully functional? • Has the machine been calibrated for this project’s aggregate and certified. Is the spreader rubber clean and not worn? • Is the texture rubber clean and set at the right angle? • Are all paddles in the pug mill intact? • Is the spreader box clean and is it a micro surfacing type box?
Rolling	<ul style="list-style-type: none"> • Do the roller tire pressures comply with the manufacturer’s specification? • What type roller will be used on the project (pneumatic-tired roller recommended)? • Do the roller tire size, rating, and pressures comply with manufacturer’s recommendations? • Is the pressure in all tires the same? • Do all tires have a smooth surface?
Stockpile	<ul style="list-style-type: none"> • Is the stockpile site well drained and clean? • Does the Contractor have all of the equipment required at the stockpile site (loaders, tankers, and so on)?

Table 9-10 Field Considerations (Continued)

Equipment Inspection Considerations	
Equipment for Continuous Run Operations	<ul style="list-style-type: none"> • Is all equipment free of leaks? • Are “Flow boys” or other nurse units clean and functional? • Are there enough units to allow continuous running with minimal stops for cleaning box rubbers?
Site Considerations	
Weather Requirements	<ul style="list-style-type: none"> • Have air and surface temperatures been checked at the coolest location on the project? • Do air and surface temperatures meet agency requirements? • Are adverse weather conditions expected? High temperatures, humidity, and wind will affect how long the emulsion takes to break. • The application of the slurry surfacing does not begin if rain is likely? • Are freezing temperatures expected within 24 hours of the completion of any application runs?
Traffic Control	<ul style="list-style-type: none"> • Do the signs and devices used match the traffic control plan? • Does the work zone comply with Caltrans requirements? • Flaggers do not hold the traffic for extended periods of time? • Unsafe conditions, if any, are reported to a supervisor (contractor or agency)? • The pilot car leads traffic slowly, 24 mph (40 km/h) or less, over fresh micro surfacing? • Signs are removed or covered when they no longer apply?
Application Considerations	
Determining Application Rates	<ul style="list-style-type: none"> • Have agency guidelines and requirements been followed? • Have rut filling and leveling course application rates been calculated or estimated separately? • Has a full mix design been done? • Is more material applied to dried-out and porous surfaces? • Is more material applied on roads with low traffic volumes? • Is less material applied to smooth, non-porous, and asphalt-rich surfaces? • Has moisture content been adjusted in the application rate?

Table 9-10 Field Considerations (Continued)

Project Inspection Responsibilities	
Micro Surfacing Application	<ul style="list-style-type: none"> • Has a test strip been done and is it satisfactory? • Have field tests been carried out and are the results within specification? • Are enough trucks on hand to keep a steady supply of material for the slurry machine? • Does the application start and stop with neat, straight edges? Will an edge box be used? • Is a rut box is used for ruts deeper than ½" (12 mm)? • Is a leveling course used with a steel strike-off for ruts less than ½" (12 mm)? Two courses are used where rut filling or leveling is employed. • Does the application start and stop on building paper or roofing felt? • Are drag marks present due to oversize aggregate or dirty rubbers? • Are rubbers cleaned regularly and at the end of each day? • Does the machine take a straight, even line with minimal numbers of passes to cover the pavement? • Is the mix even and consistent? • Are fines migrating to the surface? • Is the application stopped as soon as any problems are detected? • Does the application appear uniform? • Does the surface have an even and uniform texture? • Is the application rate checked based on amounts of aggregate and emulsion used? • What is the time between spreading, foot traffic, and opening to vehicular traffic?
Rolling	<ul style="list-style-type: none"> • Does rolling wait until the mat is stable? Roller is 5-6 tones (7) maximum. • Is the entire surface rolled only once? • Do the rollers travel slowly, 5 mph (8-9 km/h) maximum?
Truck Operation	<ul style="list-style-type: none"> • Are trucks staggered across the fresh seal coat to avoid driving over the same area? • Do trucks travel slowly on the fresh seal? • Are stops and turns made gradually? • Do truck operators avoid driving over the micro surfacing? • Do truck operators stagger their wheel paths when backing into the paving unit?

Table 9-10 Field Considerations (Continued)

Project Inspection Responsibilities	
Longitudinal Joints	<ul style="list-style-type: none"> • Is the meet line overlapped a maximum of 3 in (75 mm)? • Do the spreader box runners avoid running on fresh mat? • Are the meet lines made at the center of the road, center of a lane, or edge of a lane not in the wheel paths?
Transverse Joints	<ul style="list-style-type: none"> • Do all applications begin and end on building paper? • Mixture is not too wet at start up? • Is the building paper disposed of properly?
Brooming	<ul style="list-style-type: none"> • Does brooming begin after the micro surfacing can carry traffic? • Does brooming dislodge the micro surfacing? • Is the surface raveling? Follow-up brooming should be done if raveling is high or if traffic is high.
Opening the Micro Surfacing to Traffic	<ul style="list-style-type: none"> • Does the traffic travel slowly - 24 mph (40 kph) or less over the fresh micro surfacing? • Are reduced speed limit signs used when pilot cars are not used? • After brooming, have pavement markings been placed before opening to traffic? • Have all construction-related signs been removed when opening to normal traffic?
Clean Up	<ul style="list-style-type: none"> • Have all loose aggregate from brooming been removed from traveled way prior to opening to traffic? • Have all binder spills been cleaned up?

9.7 REFERENCES

California Department of Transportation, 2025. Standard Specifications, Sacramento, California.

California Department of Transportation, 1999. Caltrans Code of Safe Operating Practices, Chapter 12, Sacramento, California.

California Department of Transportation, 2002. Micro surfacing Pilot Study 2001, Final Report, Sacramento, California.

Holleran, G., 2001a. ABC's of Slurry Surfacing, Asphalt Contractor Magazine, July 2001.
Holleran, G., 2001b. Micro surfacing, Bitumen Asia 2001, Singapore, Asia.

Holleran, G., 2002. Slurry Surfacing Workshop—The Benefits of Polymer Modification in Slurry Surfacing, International Slurry Surfacing Association, Las Vegas, Nevada.

International Slurry Surfacing Association (ISSA), 1990. Design Technical Bulletins.

International Slurry Surfacing Association (ISSA), 2005. Recommended Performance Guidelines for Micro surfacing, Annapolis, Maryland.

Schilling, P., 2002. Success with Bituminous Emulsions Requires a Well-Balanced Chemistry of Emulsions, Bitumen and Aggregate, International Slurry Surfacing Association Conference, Berlin, Germany.

Van Kirk, J., 2000. Long Lasting Slurry Pavements, International Slurry Seal Association Conference.

Note: Caltrans manuals referenced above may have later editions than those cited. Refer to the latest editions of these references for the most current information.