

BILL OF MATERIALS

ITEM	QTY	DESCRIPTION	CT DWG # / MF #	CT STK #
△2 101	AS REQ'D	DECAL, REFLECTIVE ORANGE SHEET, 5" WIDE	MATERIAL PER SPECIFICATION	053-4813
△3 102	2	DECAL, 'CT' WHITE REFLECTIVE, 9" X 12"	03-D004-01	053-4760
△3 103	2	DECAL, 'CALTRANS' BLACK SCRIPT, 2 1/2"	03-D005-01	053-4763
104	1	DECAL, 'CT CALTRANS' ORANGE SCRIPT, 3"	03-D014-01	053-4802
105	1	APPROVED PUBLIC AWARENESS CAMPAIGN BUMPER STICKER	X	.
106	1	STRIPING, ORANGE/WHITE DIAG., REFLECTIVE, 8" X 8'	MATERIAL PER SPECIFICATION	053-2047
△4 107	1	EO. ID # & MC # DECALS - SPECIAL ORDER	X	053-4892
108	△5	APPROPRIATE FUEL TYPE DECAL: 'DIESEL ONLY'	X	053-1511

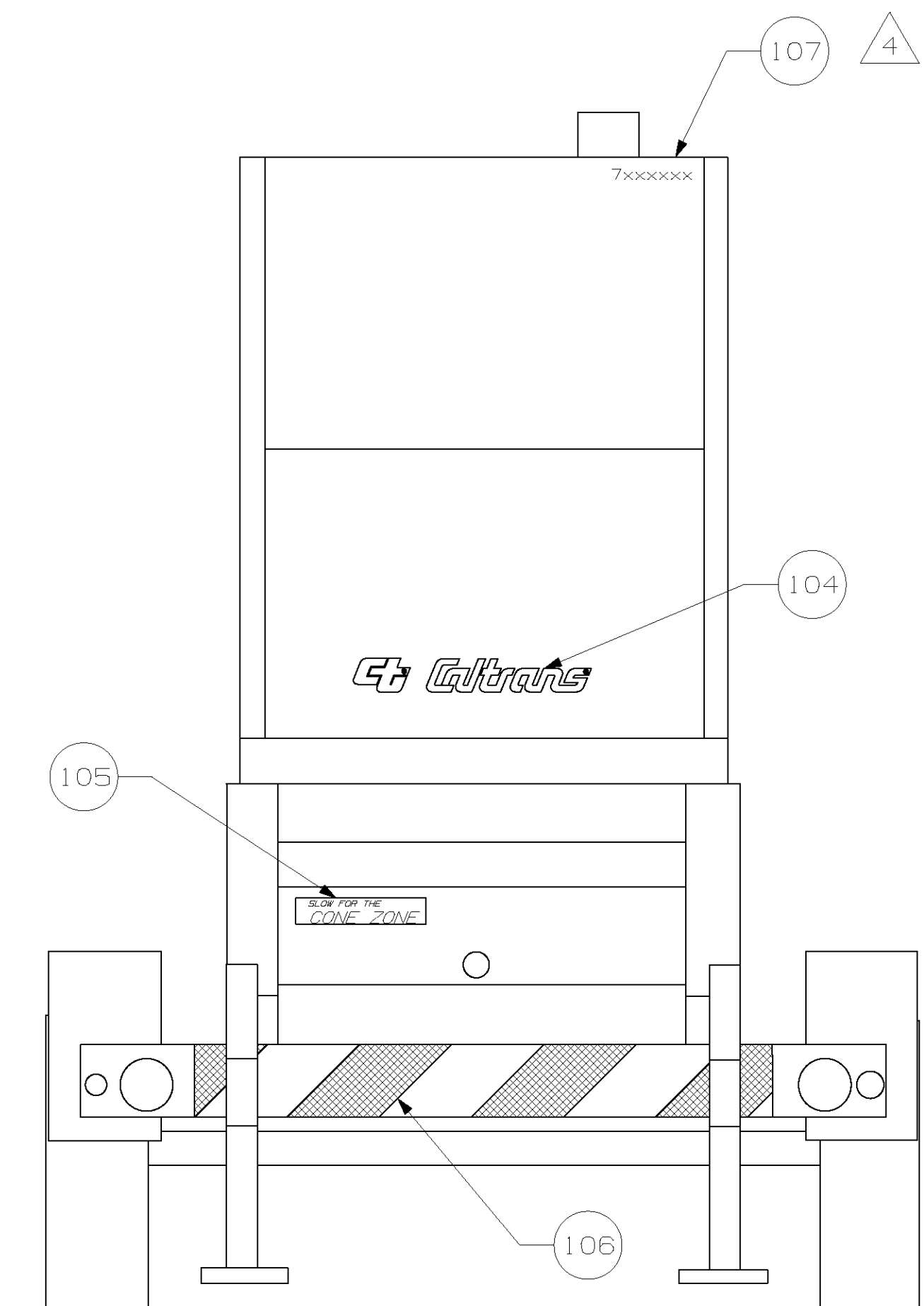
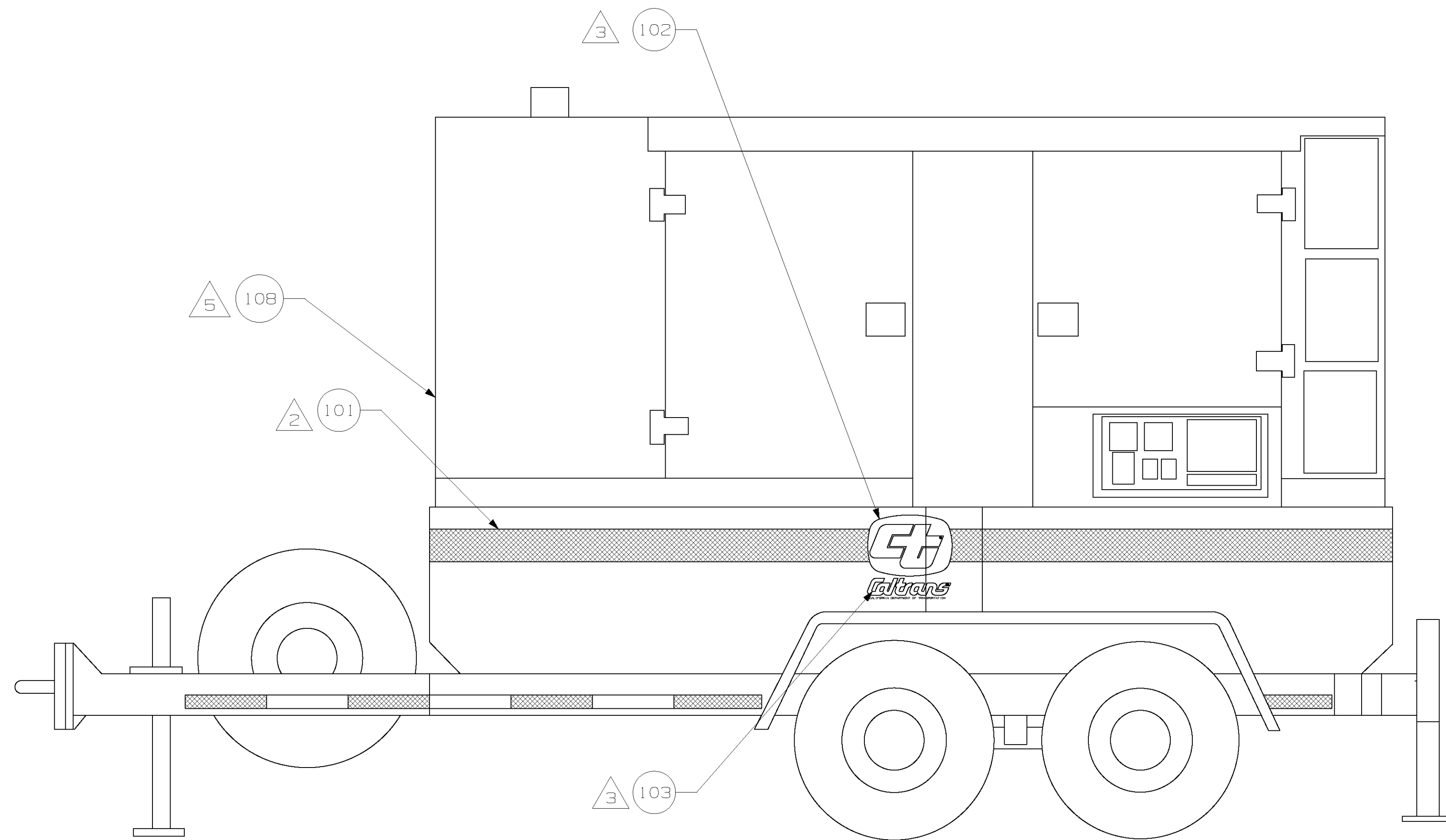

NOTES:

1. ALL DELINEATION WILL BE IN COMPLIANCE WITH CALTRANS EQUIPMENT QUALITY STANDARDS. GO TO www.dot.ca.gov/hq/eqsc TO VIEW EQUIPMENT QUALITY STANDARDS.

△2 STRIPING APPLICATION: ALL STICKERS, LABELS AND STRIPING SHALL BE LEVEL, STRAIGHT, BUBBLE-FREE AND DEBRIS-FREE. NO SPLICING OF TAPE OR STRIPING SHALL BE ACCEPTABLE. ALL EDGES ON STRIPING SHALL BE TRIMMED 1/8-3/8 INCH FROM THE EDGES OF DOORS, PANELS, FENDERS, LIGHTS, EMBLEMS, ETC. ORANGE REFLECTIVE SHEETS (ITEM 101) AND STRIPING (ITEM 107) SHALL BE TRIMMED TO MATCH BODY CONTOURS AND CREASES WHEN IT WILL NOT LAY HORIZONTAL. ANY REFLECTIVE TYPE OF STRIPE OR STICKER SHALL NOT BE PULLED FROM THE VEHICLE AND REAPPLIED DURING APPLICATION, SINCE THE REFLECTIVE MATERIAL WILL BE COMPROMISED.

△3 ITEM 101 TO BE LOCATED SUCH THAT ITEM 102 "CT" LOGO IS CENTERED ON STRIPE ITEM 101. ITEM 103 TO BE LOCATED BELOW THE "CT" LOGO

△4 SEVEN-DIGIT EQUIPMENT IDENTIFICATION NUMBER (EO. ID #) ALWAYS STARTS WITH A "7" AND SHALL BE AFFIXED TO THE REAR OF THE VEHICLE IN THE UPPER RIGHT CORNER.

△5 QUANTITY OF MC# AND FUEL TYPE DECALS MAY VARY BY CHASSIS SUPPLIER.

COPYRIGHT 2015 CALIFORNIA DEPARTMENT OF TRANSPORTATION. ALL RIGHTS RESERVED
THIS DOCUMENT CONTAINS CONFIDENTIAL AND PROPRIETARY INFORMATION THAT CANNOT BE REPRODUCED OR DIVULGED, IN WHOLE OR IN PART, WITHOUT WRITTEN AUTHORIZATION FROM CALTRANS DIVISION OF EQUIPMENT, OFFICE OF ENGINEERING AND PRODUCTION

REV	DESCRIPTION	BY
NEXT ASSEMBLY	STATE OF CALIFORNIA DIVISION OF EQUIPMENT	
XX	DIVISION OF EQUIPMENT	
TOLERANCE-UNLESS OTHERWISE SPECIFIED	TRAILER MOUNTED GENERATOR, 175 kW DELINEATION	
DECIMAL ± XX	SCALE XX	DATE 13 Jan 16
FRACTIONAL ± XX	DRAWN J Payne	DESIGNED XX
ANGULAR ± XX	CHECKED	APPROVED
DRILLED HOLES ± XX		
REAMED HOLES ± XX		
		I-35720-DE
		SHEET 1 OF 1 SHEETS