

**CALTRANS  
SEISMIC DESIGN SPECIFICATIONS  
FOR STEEL BRIDGES**

**Second Edition**



**State of California  
Department of Transportation**

**May 2016**



California Department of Transportation  
1801 30th Street  
Sacramento, CA  
95816-8041  
[www.dot.ca.gov](http://www.dot.ca.gov)

# Memorandum

*Making Conservation  
a California Way of Life.*

To: STRUCTURE POLICY BOARD

Date: April 29, 2019

From: RUTH FERNANDES <sup>RUF</sup>  
Deputy Division Chief (A)  
Structure Policy & Innovation  
Division of Engineering Services

Subject: **IMPLEMENTATION OF SEISMIC DESIGN CRITERIA VERSION 2.0**

Effective September 1, 2019, all ordinary bridges without a previous Type Selection approval shall be designed in accordance with Caltrans Seismic Design Criteria Version 2.0 (SDC 2.0). All projects with a Type Selection approval before September 1, 2019, shall have the option to either continue using the SDC version approved at the time of Type Selection or may use SDC 2.0 at the discretion of the Project Engineer.

SDC Version 2.0 incorporates technical revisions, clarifications, additional design provisions, and editorial enhancements to SDC Version 1.7, including a code-and-commentary format. A summary of changes for SDC 2.0 and the unformatted comprehensive document (SDC 2.0 Full Version, OEE Release) may be found at:

[http://www.dot.ca.gov/hq/esc/earthquake\\_engineering/sdc/index.php#SDC](http://www.dot.ca.gov/hq/esc/earthquake_engineering/sdc/index.php#SDC).

To achieve timely updates of the SDC, the Office of Earthquake Engineering, Analysis and Research (OEEAR) is posting the comprehensive document, which is technically complete, prior to final formatting by Caltrans Division of Engineering Services, Technical Publications Unit. Upon completion, the formatted version will be posted at:

<http://www.dot.ca.gov/hq/esc/techpubs/>

This memo should be forwarded to all staff, as applicable. For questions or concerns regarding the technical content of the SDC, Consultants and Local Agencies should contact the Caltrans Structure Liaison Engineer. Caltrans staff may contact the Office Chief of OEEAR, Mark Mahan, at (916) 227-8404 or [mark.mahan@dot.ca.gov](mailto:mark.mahan@dot.ca.gov).

c: Janice Benton, Chief, Division of Design  
Ray Zhang, Chief, Division of Local Assistance  
Dennis Agar, Chief, Division of Maintenance  
Thomas A. Ostrom, Chief, Division of Engineering Services  
Chris Mooring, Branch Chief, DES Administration

## PREFACE

Seismic bridge design has been evolving based on research findings and lessons learned from past earthquakes. Caltrans shifted to a displacement-based design approach emphasizing capacity design after the 1994 Northridge earthquake. A displacement-based document, *Caltrans Seismic Design Criteria (SDC)*, Version 1.1, which focused mainly on typical new concrete bridges, was published in July 1999. The *Caltrans Guide Specifications for Seismic Design of Steel Bridges (Guide)*, the first edition, was published in December 2001.

In the 14 years since the first edition of the *Guide* was published, Caltrans adopted the *AASHTO LRFD Bridge Design Specifications* beginning in 2006 and has published several versions of the *SDC*, the latest being *SDC* Version 1.7 in 2013; the American Institute of Steel Construction (AISC) updated its *Seismic Provisions for Structural Steel Buildings* in 2010; and significant research progress has been made on the seismic design of steel bridges including shear links, buckling-restrained braces, ductile end cross frames and integral bent cap connections. With the aid of all this information, the *Guide* has been completely revised, updated and renamed the *Caltrans Seismic Design Specifications for Steel Bridges (Specifications)*. The most significant changes of the second edition are related to shear links, buckling-restrained braces, ductile end cross frames and integral bent cap connections. A new chapter, “Slab-on-Steel Girder Bridges”, is added to implement state-of-the-art research and practice. All chapters were developed as a consensus document to achieve uniformity in seismic design of steel bridges in California. The *Specifications* are supplemental to the current *SDC* and shall be applied in conjunction with the current Caltrans adopted *AASHTO LRFD Bridge Design Specifications* and the *California Amendments*.

The *Specifications* are presented in a side-by-side column format with the specification text placed in the left column and the corresponding commentary text printed in the right column. The *Specifications* consist of seven chapters and six appendices. The Commentaries are prepared to provide background information concerning the development of the *Specifications*.

The development of the second edition of the *Specifications* was a joint team effort product of the Structural Steel Committee, the Earthquake Engineering Committee, and included many people who gave unselfishly of their time and talent. This effort is gratefully acknowledged. Following is the recognition of those individuals who were instrumental in producing the *Specifications*.

### **Task Group - Substantial Contribution:**

Lian Duan, Greg Slocum, Rodney Simmons, Larry Wu, Bill Addlespurger, Eugene Thimhardy, Yusuf Saleh, Richard Tsang, Christian Unanwa, Mark Mahan, Toorak Zokaie and Tariq Masroor.

### **Internal Comment and Review:**

Steve Altman, John Babcock, Janet Barnett, Brian Boal, James Choi, Nina Choy, Paul Chung, Jason Fang, Eric Fornera, Richard Heninger, Susan Hida, Kelly Holden, Kumi Jayananth, Yong-Pil Kim, Don Lee, Wenyi Long, Thomas Ostrom, Gudmund Setberg, and Charles Sikorsky.

### **External Comment and Review:**

Chia-Ming Uang, University of California at San Diego; Joel Lanning, California State University at Fullerton; Michel Bruneau, State University of New York at Buffalo; Ahmad Itani, University of Nevada at Reno; Eric V. Monzon, West Virginia University Institute of Technology; Peter Dusicka, Portland State University; Stephen A. Mahin, University of California at Berkeley; and Caltrans Seismic Advisory Board, in particular John Kulicki.

**Thomas A. Ostrom**  
**State Bridge Engineer**  
**Deputy Division Chief**  
**Structure Policy and Innovation**  
**Division of Engineering Services**



This page is intentionally left blank.



## TABLE OF CONTENTS

<b>PREFACE</b>	i
<b>DEFINITIONS</b>	vii
<b>NOTATION</b>	x
<b>1. INTRODUCTION</b>	1
1.1. Scope	1
1.2. Referenced Specifications and Standards	2
<b>2. GENERAL PROVISIONS</b>	3
2.1. Bridge Categories	3
2.2. Seismic Demands	3
2.3. Earthquake Resisting Systems and Structural Component Classification	3
2.4. Materials	5
2.5. Damage Levels, Strains and Ductility in Structural Steel	6
2.6. Design Basis	8
2.6.1. Displacements	8
2.6.2. Forces	9
2.6.3. Overstrength	9
2.6.4. Design Strength	10
2.6.5. Expected Nominal Strength	10
2.6.6. Idealized Plastic Strength	10
<b>3. STRUCTURAL ANALYSIS</b>	11
3.1. Analysis Methods	11
3.1.1. General	11
3.1.2. Moment-Curvature Analysis	12
3.1.3. Displacement Magnification for Short-Period Structures	13
3.2. Structural Modeling	13
3.2.1. General	13
3.2.2. Materials	14
3.2.3. Geometry	15
3.2.4. Initial Imperfection	15
3.2.5. Effective Section Properties	16
3.3. Effective Length of Compression Members	17
<b>4. DESIGN REQUIREMENTS</b>	18
4.1. Proportions	18
4.2. Limiting Width-To-Thickness Ratios	18
4.3. Limiting Slenderness Ratios	21
4.4. Plastic Regions	21
4.5. Member Designation	21
4.6. Special Bracings at Plastic Hinge Locations	22
4.7. Stability Bracings at Beam-To-Column Connections	24
4.7.1. Braced Connections	24
4.7.2. Unbraced Connections	24
4.8. Built-Up Members	24



<b>5. DUCTILE EARTHQUAKE RESISTING SYSTEMS</b>	<b>25</b>
5.1. Moment Frames	25
5.1.1. General	25
5.1.2. Force Demands	25
5.1.3. Moment Ratio	26
5.1.4. Columns	27
5.1.4.1. General	27
5.1.4.2. Plastic Regions	27
5.1.4.3. Expected Nominal Shear Strength	28
5.1.5. Beams	29
5.1.6. Beam-to-Column Connections	29
5.2. Centrally Braced Frames	30
5.2.1. General	30
5.2.2. Force Demands	30
5.2.2.1. Columns and Beams	30
5.2.2.2. Beam-to-Column Connections	30
5.2.2.3. Brace Connections	31
5.2.3. Lateral Force Distribution	31
5.2.4. V-type and Inverted V-type Braces	31
5.2.5. Diagonal Braces	32
5.2.5.1. General	32
5.2.5.2. Overstrength Force	32
5.2.5.3. Idealized Plastic Strength	32
5.2.5.4. Expected Nominal Strength	32
5.2.5.5. Built-up Braces	33
5.2.5.6. Plastic Regions	33
5.2.6. Columns	34
5.2.7. Beams	34
5.2.8. Connections	34
5.2.8.1. Beam-to-Column Connections	34
5.2.8.2. Brace Connections	34
5.3. Eccentrically Braced Frames	35
5.3.1. General	35
5.3.2. Force Demands	35
5.3.3. Link Rotation Angle	36
5.3.4. Links	37
5.3.4.1. General	37
5.3.4.2. Idealized Plastic Shear Strength	37
5.3.4.3. Expected Nominal Shear Strength	37
5.3.4.4. Link Length	38
5.3.4.5. Link Stiffeners for I-Shaped Sections	38
5.3.4.6. Link Stiffeners for Box Sections	39
5.3.4.7. Plastic Regions	40
5.3.5. Diagonal Braces	40
5.3.6. Columns	40
5.3.7. Beams	41
5.3.8. Connections	41
5.3.8.1. Beam-to-Column Connections	41
5.3.8.2. Brace Connections	41



5.4.	Buckling-Restrained Braced Systems	42
5.4.1.	General	42
5.4.2.	Force Demands	42
5.4.3.	Braces	43
5.4.3.1.	Assembly	43
5.4.3.2.	Adjusted Brace Strength	43
5.4.3.3.	Plastic Regions	44
5.4.4.	Qualification Tests	44
5.4.4.1.	General	44
5.4.4.2.	Loading Sequence 1	45
5.4.4.3.	Loading Sequence 2	46
5.4.4.4.	Acceptance Criteria	47
5.4.5.	V-type and Inverted V-type Braces	47
<b>6.</b>	<b>SLAB-ON-STEEL GIRDER BRIDGES</b>	<b>51</b>
6.1.	General	51
6.2.	Ductile Substructures	51
6.2.1.	General	51
6.2.2.	End Cross Frames	51
6.3.	Ductile End Cross Frames	52
6.3.1.	General	52
6.3.2.	Displacement Capacities	52
6.3.3.	Force Demands on Substructures	53
6.3.4.	Concentrically Braced Frames	53
6.3.4.1.	General	53
6.3.4.2.	Force Demands	53
6.3.4.3.	Diagonal Braces	54
6.3.4.4.	Top Chords	55
6.3.5.	Eccentrically Braced Frames	55
6.4.	Seismically Isolated Bridges	56
6.4.1.	General	56
6.4.2.	Seismic Isolation Bearings	56
6.4.3.	Force Demands	56
6.5.	Integral Connection Systems	56
6.5.1.	General	56
6.5.2.	Steel Girder Superstructures	57
6.5.2.1.	General	57
6.5.2.2.	Force Demands	57
6.5.2.3.	Expected Nominal Strength	57
6.5.3.	Concrete Columns	57
6.5.4.	Concrete Bent Cap Beams	57
6.6.	Concrete End Diaphragms at Abutments	58
6.7.	Shear Connectors	58
6.8.	Seat Width	60
6.9.	Restraining Components	60
6.9.1.	General	60
6.9.2.	Steel Pipe Shear Keys	61





6.10. Bearing Assemblies	62
6.10.1. General	62
6.10.2. Force Demands	62
6.10.3. Expected Nominal Strength	62
<b>7. CONNECTIONS AND SPLICES</b>	<b>63</b>
7.1. General	63
7.2. Beam-To-Column Connections	63
7.3. Brace Connections	64
7.4. Splices	65
7.5. Connection Elements	65
7.5.1. General	65
7.5.2. Limiting Unsupported Edge Length to Thickness Ratio	65
7.5.3. Expected Nominal Tensile Strength	66
7.5.4. Expected Nominal Compressive Strength	67
7.5.5. Expected Nominal Flexural Strength	68
7.5.6. Expected Nominal Shear Strength	68
7.5.7. Combined Flexural, Shear and Axial Forces	69
7.5.8. Out-of-Plane Force Consideration	69
7.6. Fasteners and Holes	70
7.7. Anchor Bolts	70
<b>APPENDIX A. STRESS-STRAIN RELATIONSHIPS FOR STRUCTURAL STEEL</b>	<b>71</b>
<b>APPENDIX B. EFFECTIVE SECTION PROPERTIES OF LATTICED MEMBERS</b>	<b>73</b>
B.1. Cross-sectional Area – $A$	73
B.2. Moment of Inertia - $I$	74
B.2.1. Lacing Bars or Battens in Plane of Web (Bending about y-y Axis in Figure B-1)	74
B.2.2. Lacing Bars or Battens in Plane of Flange (Bending about x-x axis in Figure B-1)	75
B.3. Plastic Section Modulus - $Z$	75
B.3.1. Lacing Bars or Battens in Plane of Web (Bending about y-y axis in Figure B-1)	75
B.3.2. Lacing Bars or Battens in Plane of Flange (Bending about x-x axis in Figure B-1)	75
B.4. Torsional Constant - $J$	75
<b>APPENDIX C. YIELD SURFACE EQUATIONS FOR DOUBLY SYMMETRICAL STEEL SECTIONS</b>	<b>77</b>
<b>APPENDIX D. LATERAL STIFFNESS OF STEEL GIRDER BRIDGES IN TRANSVERSE DIRECTION</b>	<b>79</b>
D.1. Fundamental Period	79
D.2. Lateral Stiffness	80
D.3. Stiffness of End Cross Frames	80
<b>APPENDIX E. EFFECT OF COMPOUND BUCKLING ON COMPRESSION STRENGTH OF BUILT-UP MEMBERS</b>	<b>82</b>
<b>APPENDIX F. REFERENCES</b>	<b>86</b>

## DEFINITIONS

The following definitions are supplemental to the definitions given in the Caltrans *Seismic Design Criteria* Version 1.7 (Caltrans 2013), the *AASHTO LRFD Bridge Design Specifications* (AASHTO, 2012), and the *California Amendments* (Caltrans, 2014a). Some commonly used definitions are repeated here for convenience.

*Block Shear Rupture* – A failure phenomenon or limit state for a bolted web connection of coped beams or any tension connection by the tearing out of a portion of a plate along the centerlines of the bolt holes. The block shear rupture strength combines tensile strength on one plane and shear strength on a perpendicular plane.

*Braced Frame* – A truss system that provides resistance to lateral forces and stability to the structural system.

*Bracing Member* - A member intended to brace a main member or part thereof against lateral movement.

*Buckling-Restrained Brace (BRB)* – A pre-fabricated, or manufactured, brace element consisting of a steel core and a buckling-restraining system.

*Buckling-Restrained Braced System (BRBS)* – A diagonally braced system employing buckling restrained Braces.

*Buckling-Restraining System* – A system of restraints that limits buckling of the steel core in *BRB*. This system includes the casing surrounding the steel core and structural elements adjoining its connections.

*Capacity-Protected Component* - A component intentionally designed to experience minimal damage and to behave in an essentially elastic manner during the design seismic hazards.

*Connection* – A combination of structural elements and joints used to transmit forces between two or more members.

*Concentrically Braced Frame (CBF)* – A diagonally braced frame in which all members of the bracing system are subjected primarily to axial forces.

*Design Seismic Hazards (DSH)* – The collection of seismic hazards at the bridge site used in the design of bridges. Earthquake ground motion loads are represented by the Design Spectrum (*DS*) specified in the *SDC* or site-specific *DS* developed by geotechnical engineers.

*Design Spectrum (DS)* – The ground shaking hazard in terms of response spectrum used in design.

*Design Strength* – Factored Resistance (axial/shear force, moment, as appropriate) provided by structural components equal to the product of the expected nominal strength and the resistance factor.

*Displacement Capacity* – Lateral displacement of a component or a system corresponding to its expected damage level limit, not to exceed that displacement when the lateral resistance degrades towards a minimum of 80 percent of the peak resistance.

*Displacement Demand* – Lateral displacement of a component or a system determined by an analysis under the *DSH*.

*Displacement Ductility* – Ratio of ultimate-to-yield displacement.

*Ductile Component* – A component that is intentionally designed to deform inelastically for several cycles without significant degradation of strength or stiffness under the demands generated by the *DSH*.

*Ductile End Cross Frame (DECF)* – A specially designed end cross frame or diaphragm in slab-on-steel-girder bridges in which inelastic deformations under lateral loads are limited to the bracing members in the end cross frames and all other components, including substructures, are expected to remain essentially elastic in the transverse direction.

*Ductility* – Ratio of ultimate-to-yield deformation.

*Earthquake-Resisting Element (ERE)* – An individual component, such as column, connection, bearing, joint, foundation, and abutment, that together constitute the earthquake-resisting system (*ERS*).

*Earthquake-Resisting System (ERS)* – A system that provides a reliable and uninterrupted load path for transmitting seismically induced forces into the ground and sufficient means of energy dissipation and/or restraint to reliably control seismically induced displacements.

*Eccentrically Braced Frame (EBF)* – A diagonally braced frame that has at least one end of each bracing member connected to a beam with a defined eccentricity from another beam-to-brace connection or a beam-to-column connection.

*Effective Length* – Length between adjacent inflection points of the pure flexural buckling shape of a compression member, i.e., a modified length of the end-restrained compression member gives the length of an equivalent pin-ended member whose buckling load is the same as that of the end-restrained member.

*Effective Length Factor (K)* – A factor that when multiplied by actual length of the end-restrained compression member gives the length of an equivalent pin-ended compression member, whose buckling load is the same as that of the end-restrained member.

*Expected Nominal Strength* – Nominal strength of a component based on its expected material properties.

*First-order Analysis* – A structural analysis in which equilibrium conditions are formulated on the undeformed structure and second-order effects are neglected.

*Fracture Critical Member (FCM)* – Component in tension whose failure is expected to result in the collapse of the bridge or the inability of the bridge to perform its functions.

*Functional Evaluation Earthquake (FEE)* – A project specific seismic ground motion that has relatively small magnitude but may occur several times during the life of the bridge. Ordinary Bridges are not designed for *FEE*.

*Idealized Plastic Strength* – Strength of a ductile component based on its expected material properties and the strain hardening at the significant damage level.

*Joint* – An area where member ends, surfaces, or edges are connected to the system by plates, fasteners or welds.

*Link* – In *EBF*, the segment of a beam that is located between the ends of two diagonal braces or between the end of a diagonal brace and a column. Under lateral loading, the link deforms plastically in shear thereby absorbing energy. The length of the link is defined as the clear distance between the ends of two diagonal braces or between the diagonal brace and the column face.

*Moment-Curvature Analysis* – A method to accurately determine load-deformation behavior of a structural section using nonlinear material stress-strain relationships.

*Moment Frame (MF)* – A framing system in which seismic forces are resisted by both shear and flexure in members, and connections of the frame.

*Expected Nominal Strength* – The capacity of a component to resist the effects of loads, as determined by computations using expected material strength and formulas derived from acceptable principles of structural mechanics or by field tests or laboratory tests of scaled models, allowing for modeling effects, and differences between laboratory and field conditions.

*Overstrength Force* – A force which primarily accounts for material strength variation between the ductile components and adjacent members, and the potential overstrength of the idealized plastic strength of a ductile component. It is taken as its idealized plastic strength multiplied by an overstrength factor.

*Overstrength Factor* – A factor which primarily accounts for material strength variation between the ductile components and adjacent members, and the potential overstrength of the idealized plastic strength of a ductile component. It is used to determine force demands on adjacent capacity-protected components.

*Panel Zone* – The web area of a beam-to-column connection intersected by the extension of column and beam flanges.

*P- $\delta$  Effect* – Effects of axial loads acting on deformed shape of a member between joints or nodes.

*P- $\Delta$  Effect* – Effects of axial loads acting on deformed location of joints or nodes in a structure. In a bridge substructure, this is the effect of axial loads acting on the laterally deformed location of bent caps.

*Rotation Ductility* – Ratio of ultimate-to-yield rotation.

*Safety Evaluation Earthquake (SEE)* – A design ground motion that has only a small probability of occurring during the life of the bridge. For Ordinary Bridges, it is the “Design Spectrum” as defined in the *SDC*. For Important Bridges, it is a ground motion with a return period of approximately 1000-2000 years.

*Second-order Analysis* – A structural analysis in which equilibrium conditions are formulated on the deformed structure and second-order effects are considered.

*Second-order Effects* – Effects of axial loads acting on the deformed geometry of a structure; includes *P- $\Delta$*  effect and *P- $\delta$*  effect.

*Splice* – The connection between two structural elements jointed at their ends to form a single, longer element.

*Steel Bridge* – A bridge in which main members of the superstructure including girders, trusses and arch ribs are made of structural steel.

*Ultimate Displacement* – The lateral displacement of a component or a frame corresponding to the expected damage level, not to exceed the displacement when the lateral resistance degrades to a minimum of 80 percent of the peak resistance.

*Ultimate Rotation* – The rotation corresponding to the expected damage level of a component when its extreme fiber reaches a strain limit, not to exceed the rotation when the moment resistance degrades to a minimum of 80 percent of the peak moment resistance.

*Upper Bound Solution* – A solution calculated on the basis of an assumed mechanism which is greater than or equal to the true solution.

*Yield Rotation* - The rotation at the onset of yielding in the extreme tension fiber.

*Yield Displacement* - The lateral displacement of a component or a frame at the onset of forming the first plastic hinge.

## NOTATION

Numbers in parentheses after the definition of a symbol refer to the Article where the symbol first appears or is used.

$a$	=	distance between two battens along the member axis (in.) (Appendix B.4)
$a$	=	length of the beam outside of a link (in.) (Appendix D.3)
$a$	=	length of each laced panel (in.) (Appendix E)
$A$	=	cross-sectional area of a steel section (in. <sup>2</sup> ) (Appendix B.1)
$A_b$	=	cross-sectional area of a batten plate (in. <sup>2</sup> ) (Appendix B.2.1)
$A_b$	=	cross-sectional area of a brace (in. <sup>2</sup> ) (Appendix D.3)
$A_{close}$	=	area enclosed within the mean dimension for a box-shaped section (in. <sup>2</sup> ) (Appendix B.4)
$A_d$	=	cross-sectional area of all diagonal lacings in one panel (in. <sup>2</sup> ) (Appendix B.4)
$A_{equiv}$	=	cross-sectional area of a thin-walled plate equivalent to lacing bars considering shear transferring capacity (in. <sup>2</sup> ) (Appendix B.4)
$A_{equiv}^*$	=	cross-sectional area of a thin-walled plate equivalent to lacing bars or battens assuming full section integrity (in. <sup>2</sup> ) (Appendix B.4)
$A_f$	=	flange area of I-shaped section (in. <sup>2</sup> ) (5.1.4.2)
$A_f$	=	flange area to which battens or laces are attached (in. <sup>2</sup> ) (Appendix B.2.1)
$A_f$	=	cross-sectional area of individual flange component (in. <sup>2</sup> ) (Appendix E)
$A_g$	=	gross cross-sectional area (in. <sup>2</sup> ) (3.2.5)
$A_g$	=	web gross area of a rectangular tube or cross-sectional area of a pipe (in. <sup>2</sup> ) (6.9.2)
$A_g$	=	area of a stiffened girder (in. <sup>2</sup> ) (Appendix D.3)
$A_i$	=	cross-sectional area of an individual main component $i$ (in. <sup>2</sup> ) (Appendix B.1)
$A_i^*$	=	cross-sectional area above or below the plastic neutral axis (in. <sup>2</sup> ) (Appendix B.3.1)
$A_l$	=	cross-sectional area of a shear link (in. <sup>2</sup> ) (Appendix D.3)
$A_n$	=	net cross-sectional area (in. <sup>2</sup> ) (7.5.1)
$A_r$	=	cross-sectional area of a fastener (in. <sup>2</sup> ) (Appendix B.2.1)
$A_{sc}$	=	cross-sectional area of the yielding segment of the steel core (in. <sup>2</sup> ) (5.4.3.2)
$A_{st}$	=	horizontal cross-sectional area of the stiffener (in. <sup>2</sup> ) (5.3.4.5)
$A_{s,l}$	=	shear area of a shear link (in. <sup>2</sup> ) (Appendix D.3)
$A_{vg}$	=	gross area subject to shear (in. <sup>2</sup> ) (7.5.6)
$A_{vn}$	=	net area subject to shear (in. <sup>2</sup> ) (7.5.6)
$A_w$	=	web area of I-shaped section (in. <sup>2</sup> ) (5.1.4.2)
$A_L$	=	cross-sectional area of an angle (in. <sup>2</sup> ) (3.2.5)
$(A_L)_{eff}$	=	effective cross section area of an angle (in. <sup>2</sup> ) (3.2.5)
$A_l$	=	bearing area of a steel pipe in concrete (in. <sup>2</sup> ) (6.9.2)
$A_2$	=	confinement concrete area equal to the embedment length of a steel pipe times the concrete edge width bound by two 45° lines drawn from the outside diameter of the pipe to the edge of concrete element (in. <sup>2</sup> ) (6.9.2)
$b$	=	width of a flange (in.) (Table 4.2-1)
$b$	=	width of a gusset plate perpendicular to the edge (in.) (7.5.2)
$b_f$	=	beam flange width (in.) (4.7.1)
$b_i$	=	length of the particular segment of a section (in.) (Appendix B.4)
$b_s$	=	stiffener width for one-sided stiffener, twice the individual stiffener width for pairs of stiffeners (in.) (4.6)
$\bar{B}$	=	ratio of width to depth of box section with respect to bending axis (5.1.4.2)

- $C_b$  = lateral torsional buckling modification factor for nonuniform moment determined by Article 6.10.8.2.3 of the *AASHTO BDS*, for single curvature with one pin-end,  $C_b = 1.75$ ; for double curvature with equal end moments,  $C_b = 2.3$  (4.6)
- $d$  = depth of stem of a tee section (in.) (Table 4.2-1)
- $d$  = full depth of a link (in.) (5.3.4.5)
- $d_g$  = overall girder depth (in.) (7.2)
- $d_o$  = intermediate stiffener spacing (in.) (5.3.4.5)
- $d_z$  = panel zone depth between continuity plates (in.) (7.2)
- $D$  = outside diameter of a steel hollow structural section (HSS) (in.) (Table 4.2-3)
- $D$  = web depth, clear distance between flanges (in.) (5.3.3)
- $e$  = shear link length, the clear distance between the ends of two diagonal braces or between the diagonal braces and the column face (in.) (5.3.3)
- $E$  = modulus of elasticity of steel = 29,000 ksi (3.2.5)
- $(EI)_{eff}$  = effective flexural stiffness (kip-in.<sup>2</sup>) (3.2.5)
- $f_b$  = shape factor, ratio of plastic moment to yield moment of a steel section subject to flexure (5.1.4.2)
- $f_{bc}$  = shape factor, ratio of plastic moment to yield moment of a steel section subject to combined axial force and flexure (5.1.4.2)
- $f_s$  = stress in steel (ksi) (C2.5)
- $f_y$  = specified minimum yield strength of reinforcing steel (ksi) (6.10.3)
- $f_{ye}$  = expected yield strength of reinforcing steel (ksi) (6.10.3)
- $f'_c$  = specified compressive strength of concrete at 28 days (ksi) (6.9.2)
- $F_{sb}$  = rupture stress of steel (ksi) (C2.5)
- $F_u$  = specified minimum tensile strength of steel (ksi) (2.4)
- $F_u$  = specified minimum tensile strength of fasteners (ksi) (Appendix B.2.1)
- $F_{ue}$  = expected tensile strength of steel (ksi) (2.4)
- $F_y$  = specified minimum yield strength of steel (ksi) (2.4)
- $F_{ye}$  = expected yield strength of steel (ksi) (2.4)
- $F_{yesc}$  = expected yield strength of the steel core =  $R_y F_y$ , or the measured yield strength of the steel core determined from a coupon test (ksi) (5.4.3.2)
- $F_{yf}$  = specified minimum yield strength of a flange component (ksi) (Appendix B.2.1)
- $F_{yst}$  = specified minimum yield strength of the stiffener (ksi) (5.3.4.5)
- $F_{yw}$  = specified minimum yield strength of a web component including battens or lacing bars (ksi) (Appendix B.2.1)
- $F_C$  = design strength, or factored resistance (axial/shear force and moment as appropriate) of a capacity-protected component (2.6.2)
- $F_D$  = force demand (axial/shear force and moment as appropriate) on a capacity-protected component determined by the overstrength forces of adjacent ductile components (2.6.2)
- $h$  = depth of web (in.) (Table 4.2-2)
- $h$  = frame height (in.) (C5.3.3)
- $h$  = depth of a member in the lacing plane (in.) (Appendix B.4)
- $h$  = height of a girder bridge =  $h_{sup} + h_{sub} + h_{bear}$  (in.) (Appendix D.2)
- $h$  = distance between centroids of individual components perpendicular to the member axis of buckling (in.) (Appendix E)
- $h_o$  = distance between flange centroids (in.) (4.6)
- $h_{bear}$  = height of a bearing (in.) (Appendix D.2)
- $h_{sg}$  = height of a stiffened steel girder (in.) (Appendix D.3)
- $h_{sub}$  = height of the substructure (in.) (Appendix D.2)
- $h_{sup}$  = height of the girder superstructure measured from the bottom of the girder flange to central gravity of the concrete deck (in.) (Appendix D.2)
- $H$  = distance between working points (in.) (3.2.4)

$I$	=	moment of inertia of a steel section in plane of bending (in. <sup>4</sup> ) (3.2.5)
$I_b$	=	moment of inertia of a batten plate (in. <sup>4</sup> ) (Appendix B.4)
$I_{eff}$	=	effective moment of inertia of a ductile concrete member (in. <sup>4</sup> ) (C3.2.5)
$I_f$	=	moment of inertia of one side of solid flange about weak axis (in. <sup>4</sup> ) (Appendix B.4)
$I_f$	=	moment of inertia of individual flange component relative to its centroidal axis parallel to member axis of buckling (in. <sup>4</sup> ) (Appendix E)
$I_i$	=	moment of inertia of a main individual component $i$ (in. <sup>4</sup> ) (Appendix B.2.1)
$I_l$	=	moment of inertia of a shear link (in. <sup>4</sup> ) (Appendix D.3)
$I_s$	=	moment of inertia of a longitudinal stiffener about an axis parallel to the bottom flange and taken at the base of the stiffener (in. <sup>4</sup> ) (Table 4.2-3)
$I_s$	=	moment of inertia of a stiffener about its strong axis (in. <sup>4</sup> ) (7.5.2)
$I_{sg}$	=	moment of inertia of the effective column section (as specified in Article 6.10.11.2.4b of the <i>AASHTO BDS</i> ) for a bearing stiffener about the web (in. <sup>4</sup> ) (Appendix D.3)
$I_{x-x}$	=	moment of inertia about the $x-x$ axis (in. <sup>4</sup> ) (Appendix B.2.2)
$I_y$	=	moment of inertia about the weak axis (in. <sup>4</sup> ) (4.6)
$I_{y-y}$	=	moment of inertia about the $y-y$ axis (in. <sup>4</sup> ) (Appendix B.2.1)
$I_g$	=	moment inertia of a gusset plate in the plane of bending (in. <sup>4</sup> ) (3.2.5)
$I_L$	=	moment inertia of an angle in the plane of bending (in. <sup>4</sup> ) (3.2.5)
$J$	=	torsion constant (in. <sup>4</sup> ) (Appendix B.4)
$J_{eff}$	=	effective polar moment of inertia of a ductile concrete member (in. <sup>4</sup> ) (C3.2.5)
$k$	=	plate buckling coefficient specified by Article 6.11.8.2.3 of the <i>AASHTO BDS</i> (Table 4.2-3)
$K$	=	effective length factor for a compression member in the plane of buckling (3.3)
$K_{bear}$	=	lateral stiffness of bearings at bent (kip/in.) (Appendix D.2)
$K_{endf}$	=	lateral stiffness of an end cross frame/diaphragm (kip/in.) (Appendix D.3)
$K_{trans}$	=	lateral stiffness of a bent in the transverse direction (kip/in.) (Appendix D.1)
$K_{sg}$	=	lateral stiffness of a steel girder (kip/in.) (Appendix D.3)
$K_{sub}$	=	lateral stiffness of the substructure at a bent (kip/in.) (Appendix D.2)
$K_{sup}$	=	lateral stiffness of the superstructure at a bent (kip/in.) (Appendix D.2)
$l$	=	distance from the Whitmore section perpendicular to the interior corner of the gusset (in.) (C7.5.4)
$l_d$	=	embedment length of a steel pipe (in.) (6.9.2)
$L$	=	length of member (in.) (4.6)
$L_b$	=	member length between brace or framing point (in.) (3.2.4)
$L_b$	=	unbraced length of a compression member (in.) (4.3)
$L_b$	=	brace length (in.) (Appendix D.3)
$L_b$	=	laterally unsupported length of a built-up member in buckling plane (in.) (Appendix E)
$L_g$	=	unsupported length of a gusset plate (in.) (7.5.2)
$L_g$	=	distance between the edge of the connecting angel and the end of a gusset plate (in.) (3.2.5)
$L_o$	=	distance between the point of maximum moment and the point of contra-flexure (in.) (5.1.4.2)
$L_p$	=	theoretical plastic hinge length (in.) (5.1.4.2)
$L_s$	=	girder spacing (in.) (Appendix D.3)
$L_1$	=	distance from the centerline of the Whitmore section to the interior corner of a gusset (in.) (C7.5.4)
$L_2, L_3$	=	distance from the outside corner of the Whitmore section to the edge of a member; negative value shall be used when the part of Whitmore section enters into the member (in.) (C7.5.4)
$L_L$	=	length of a angle (in.) (3.2.5)
$m$	=	number of panels between the point of maximum calculated moment to the point of zero moment to either side (as an approximation, the number of panels in half of the main member length ( $L/2$ ) may be used) (Appendix B.2.1)
$m$	=	sum of the superstructure mass and a half of substructure mass in the tributary length of bridge (kip-sec <sup>2</sup> /in.) (Appendix D.1)
$m_b$	=	number of batten planes (Appendix B.2.1)

- $m_l$  = number of lacing planes (Appendix B.2.1)  
 $M_l$  = end moment demand of a column based on the first-order analysis under the *DSH* (kip-in.) (3.2.3)  
 $M_{ip}$  = idealized plastic moment capacity of the column based on its expected material properties and the strain hardening at the significant damage level. It can be obtained by either a moment-curvature analysis or approximately equal to  $1.17M_{pe}$  (kip-in.) (5.1.3).  
 $M_{ne}$  = expected nominal flexural strength of the beam (kip-in.) (5.1.3)  
 $M_{oc}$  = overstrength moment of a ductile column =  $\Omega M_{ip}$  (kip-in.) (5.1.3)  
 $M_p$  = nominal plastic flexural strength (kip-in.) (5.3.3)  
 $M_{p-b}$  = plastic moment of a batten plate about the strong axis (kip-in.) (Appendix B.2.1)  
 $M_{pcx}$  = moment capacity about the *x-x* axis, reduced for the presence of axial force (kip-in.) (Appendix C)  
 $M_{pcy}$  = moment capacity about the *y-y* axis, reduced for the presence of axial force (kip-in.) (Appendix C)  
 $M_{pe}$  = expected nominal flexural strength of a shear link (kip-in.) (5.3.4.3)  
 $M_{pe}$  = expected plastic moment capacity of the column determined by yield surface equations in Appendix C based on the expected yield strength  $F_{ye}$ , or approximated as  $Z_c(F_{ye}-P_u/A_g)$  (kip-in.) (5.1.3)  
 $M_{px}$  = plastic moment capacity about the *x-x* principal axis (kip-in.) (Appendix C)  
 $M_{py}$  = plastic moment capacity about the *y-y* principal axis (kip-in.) (Appendix C)  
 $M_{Tb}$  = moment for design of a torsional brace (kip-in.) (4.6)  
 $M_u$  = peak moment or ultimate moment (kip-in.) (C2.5)  
 $M_{ua}$  = moment demand associated simultaneously with axial and shear forces (kip-in.) (7.5.7)  
 $M_v$  = additional moment due to the shear amplification from the actual location of the column plastic hinge to the beam centerline (kip-in.) (5.1.3)  
 $M_x$  = moment about the *x-x* principal axis (kip-in.) (Appendix C)  
 $M_y$  = yield moment (kip-in.) (C2.5)  
 $M_y$  = moment about the *y-y* principal axis (kip-in.) (Appendix C)  
 $M_o^{col}$  = overstrength plastic moment of a concrete column (kip-in.) (6.5.2.2)  
 $M_{ne}^*$  = expected nominal flexural strength of a beam at the intersection of the beam and the column centerline (kip-in.) (5.1.3)  
 $M_{oc}^*$  = overstrength flexural moment in the column at the intersection of the beam and column centerlines =  $M_{oc}+M_v$  (kip-in.) (5.1.3)  
 $\sum M_{ne}^*$  = sum of the expected nominal flexural strength of the beam(s) at the intersection of the beam and the column centerlines (kip-in.) (5.1.3)  
 $\sum M_{oc}^*$  = sum of overstrength flexural moments in the column(s) above and below the joint at the intersection of the beam and column centerlines (kip-in.) (5.1.3)  
 $n$  = number of lateral bracing points within the span (4.6)  
 $n$  = number of equally spaced longitudinal compression flange stiffeners (Table 4.2-3)  
 $n_r$  = number of fasteners of the connecting lacing bar or battens to the main component at one connection (Appendix B.2.1)  
 $P$  = axial load (kip) (Appendix C)  
 $P_a$  = adjusted brace strength in compression (kip) (5.4.3.2)  
 $P_{br}$  = lateral force for design of a lateral brace (kip) (4.6)  
 $P_{bse}$  = expected nominal strength for block shear rupture determined in accordance with Article 6.13.4 of the *AASHTO BDS* except that  $F_{ye}$  and  $F_{ue}$  are used in lieu of  $F_y$  and  $F_u$ , respectively (kip) (7.5.3)  
 $P_{dl}$  = axial dead load in the column (kip) (3.2.3)  
 $P_{ne}$  = expected nominal tensile or compressive strength (kip) (7.5.3)  
 $P_{nye}$  = expected nominal tensile strength for yielding in gross section as specified in Article 6.8.2.1 of the *AASHTO BDS* except that  $F_{ye}$  is used in lieu of  $F_y$  (kip) (7.5.3)  
 $P_{t1}$  = compression force measured at time  $t_1$  (kip) (C5.4.5)



- $P_{t2}$  = compression force measured at time  $t_2$  (kip) (C5.4.5)  
 $P_u$  = axial force due to seismic and permanent loads (kip) (3.2.5)  
 $P_{ua}$  = axial force demand simultaneously associated with moment and shear forces (kip) (7.5.7)  
 $P_{nue}$  = expected nominal tensile strength for fracture in net section determined in accordance with Article 6.8.2.1 of the *AASHTO BDS* except that  $F_{ue}$  is used in lieu of  $F_u$  (kip) (7.5.3)  
 $P_y$  = axial yield strength of a steel section ( $A_g F_y$ ) (kip) (3.2.5)  
 $P_{ye}$  = expected axial yield strength of a steel section ( $A_g F_{ye}$ ) (kip) (5.1.4.2)  
 $P_n^{comp}$  = nominal compressive strength of a lacing bar determined by Article 6.9.4.1 of the *AASHTO BDS* (kip) (Appendix B.2.1)  
 $P_n^{ten}$  = nominal tensile strength of a lacing bar determined by Article 6.8.2 of the *AASHTO BDS* (kip) (Appendix B.2.1)  
 $Q$  = slender element reduction factor (3.1.2)  
 $r$  = radius of gyration about the axis perpendicular to the plan of the buckling (in.) (4.3)  
 $r$  = radius of gyration of built-up section about axis of buckling acting as a whole unit (in.) (Appendix E)  
 $r_f$  = radius of gyration of individual flange component relative to its centroidal axis parallel to member axis of buckling =  $\sqrt{I_f / A_f}$  (in.) (Appendix E)  
 $r_y$  = radius of gyration about the minor axis (in.) (4.3)  
 $R_d$  = displacement magnification factor for short-period structures (3.1.3)  
 $R_{ne}$  = expected nominal shear strength of a steel pipe or a HSS shear key (kip) (6.9.2)  
 $R_t$  = ratio of the expected tensile strength to the specified minimum tensile strength (2.4)  
 $R_y$  = ratio of the expected yield strength to the specified minimum yield strength (2.4)  
 $S_{D1}$  = *DS* acceleration coefficient at 1.0-sec (3.1.3)  
 $S_{DS}$  = *DS* acceleration coefficient at 0.2-sec (3.1.3)  
 $t$  = plate thickness (in.) (Table 4.2-1)  
 $t$  = thickness of a gusset plate (in.) (7.5.2)  
 $t_{equiv}$  = thickness of equivalent thin-walled plate (in.) (Appendix B.4)  
 $t_f$  = beam flange thickness (in.) (4.7.1)  
 $t_i$  = average thickness of a segment  $b_i$  (in.) (Appendix B.4)  
 $t_p$  = total thickness of the panel zone including doubler plates (in.) (7.2)  
 $t_{st}$  = thickness of web stiffener (in.) (4.6)  
 $t_w$  = web thickness (in.) (Table 4.2-2)  
 $T$  = fundamental period of the structure (sec.) (3.1.3)  
 $T_a$  = adjusted brace strength in tension (kip) (5.4.3.2)  
 $V_{ne}$  = expected nominal shear strength of the panel zone (kip) (7.2)  
 $V_p$  = nominal shear yield strength (kip) =  $0.58 F_y D t_w$  (5.3.3)  
 $V_{pe}$  = expected nominal shear yield strength of a link (kip) (5.3.4.3)  
 $T_{t1}$  = tension force measured at time  $t_1$  (kip) (C5.4.5)  
 $T_{t2}$  = tension force measured at time  $t_2$  (kip) (C5.4.5)  
 $V_u$  = peak lateral load or ultimate lateral load capacity (kip) (C2.5)  
 $V_u$  = shear force due to seismic and permanent loads (kip) (5.3.4.4)  
 $V_{ua}$  = shear force demand associated simultaneously with axial and flexural forces (kip) (7.5.7)  
 $V_y$  = lateral force corresponding to the onset of forming the first plastic hinge (kip) (C2.5)  
 $w_z$  = panel zone width between column flanges (in.) (7.2)  
 $x_i$  = distance between  $y$ - $y$  axis and the centroid of the main individual component  $i$  (in.) (Appendix B.2.1)  
 $x_i^*$  = distance between the center of gravity of a section  $A_i^*$  and the plastic neutral  $y$ - $y$  axis (in.) (Appendix B.3.1)

$y_i^*$	= distance between the center of gravity of a section $A_i^*$ and the plastic neutral $x$ - $x$ axis (in.) (Appendix B.3.1)
$Z$	= plastic section modulus of a plastic hinge section in the plane of bending (in. <sup>3</sup> ) (4.6)
$Z$	= plastic section modulus of a link in the plane of bending (in. <sup>3</sup> ) (5.3.3)
$Z_c$	= plastic section modulus of a column (in. <sup>3</sup> ) (5.1.3)
$Z_{x-x}$	= plastic section modulus about the $x$ - $x$ axis (in. <sup>3</sup> ) (Appendix B.3.2)
$Z_{y-y}$	= plastic section modulus about the $y$ - $y$ axis (in. <sup>3</sup> ) (Appendix B.3.1)
$\alpha$	= angle between a brace and the horizontal direction (Appendix D.3)
$\alpha$	= separation factor = $h/2r_f$ (Appendix E)
$\alpha_{bear}$	= stiffness modification factor of bearings (Appendix D.2)
$\alpha_{fix}$	= fixity factor, equal to 12 if full fixity is provided at both flanges of a steel girder; 3 if one end is fully fixed and other one pinned; and 0 if both ends are pinned (Appendix D.3)
$\alpha_p$	= stiffness reduction factor (3.2.5)
$\alpha_{sub}$	= stiffness modification factor of the substructure (Appendix D.2)
$\alpha_x$	= moment interaction parameters about the $x$ - $x$ principal axis as a function of cross section and axial force (Appendix C)
$\alpha_y$	= moment interaction parameters about the $y$ - $y$ principal axis as a function of cross section and axial force (Appendix C)
$\beta$	= buckling model interaction factor (4.8)
$\beta$	= moment-axial force interaction parameter about the principal axis depending on cross section shapes and area distribution (5.1.4.2)
$\beta$	= compression strength adjustment factor (C5.4.5)
$\beta_{br}$	= minimum brace stiffness (kip/in.) (4.6)
$\beta_m$	= reduction factor for the moment of inertia (Appendix B.2.1)
$\beta_{sec}$	= web torsional stiffness, including the effects of web transverse stiffeners (kip-in//rad) (4.6)
$\beta_t$	= reduction factor for the torsion constant (Appendix B.4)
$\beta_T$	= overall brace system stiffness (kip-in./rad) (4.6)
$\beta_{Tb}$	= minimum torsional stiffness (kip-in./rad) (4.6)
$\beta_x$	= moment-axial force interaction parameter about the $x$ - $x$ principal axis as a function of cross section (Appendix C)
$\beta_y$	= moment-axial force interaction parameter about the $y$ - $y$ principal axis as a function of cross section (Appendix C)
$\delta$	= local displacement relative to the member chord between end nodes (3.2.3)
$\delta_o$	= out-of-straightness (in.) (Appendix E)
$\phi$	= resistance factor (2.6.4)
$\phi$	= angle between a diagonal lacing bar and the axis perpendicular to the member axis (Appendix B.2.1)
$\phi_{bs}$	= resistance factor for block shear (2.6.4)
$\phi_t$	= resistance factor for fracture in the net section (2.6.4)
$\epsilon_s$	= strain in steel (2.5)
$\epsilon_{sh}$	= strain at the onset of strain hardening of steel (2.5)
$\epsilon_{ue}$	= strain corresponding to the expected tensile strength of steel (2.5)
$\epsilon_{sb}$	= rupture strain of steel (C2.5)
$\epsilon_{ye}$	= strain corresponding to the expected yield strength of steel (2.5)
$\lambda_{hd}$	= limiting width-to-thickness ratio of elements for highly ductile members in the <i>AISC Seismic Provisions</i> (C4.2)
$\lambda_{ps}$	= limiting width-to-thickness ratio of elements for ductile components (4.2)
$\lambda_r$	= limiting width-to-thickness ratio of elements for capacity-protected components (4.2)

- $\mu_{DL}$  = maximum local member displacement ductility demand (3.1.3)
- $\mu_{\Delta}$  = displacement ductility, ratio of ultimate-to-yield displacement ( $\Delta_u/\Delta_y$ ) (2.5)
- $\mu_{\theta}$  = rotation ductility, ratio of ultimate-to-yield rotation ( $\theta_u/\theta_y$ ) (2.5)
- $\theta_y$  = yield rotation, rotation corresponding to the onset of yielding in the extreme tension fiber (2.5)
- $\theta_p$  = plastic rotation angle (C5.3.3)
- $\theta_u$  = ultimate rotation capacity, rotation corresponding to its expected damage level at which the extreme fiber reaches its strain limit as specified in Table 2.5-1, not to exceed that rotation when the moment resistance degrades towards a minimum of 80 percent of the peak moment resistance (2.5)
- $\gamma_p$  = link plastic rotation angle (5.3.3)
- $\omega_C$  = strain hardening adjustment factor for compression (5.4.3.2)
- $\omega_T$  = strain hardening adjustment factor for tension (5.4.3.2)
- $\Omega$  = overstrength factor (2.6.3)
- $\Delta$  = displacement relative to member ends (3.2.3)
- $\Delta_{bm}$  = design-level deformation applicable to the *BRB* bridge application under consideration (in.) (5.4.4.2)
- $\Delta_p$  = plastic frame displacement (in.) (C5.3.3)
- $\Delta_{r,l}$  = relative lateral displacement demand between the point of contra-flexure and the end of column based on the first-order analysis under the *DSH* (in.) (3.2.3)
- $\Delta_u$  = ultimate lateral displacement capacity, the lateral displacement of a component or a system corresponding to its expected damage level limit as specified in Table 2.5-1, not to exceed that displacement when the lateral resistance degrades towards a minimum of 80 percent of the peak resistance (in.) (2.5)
- $\Delta_y$  = yield displacement, the lateral displacement of a component or a system at the onset of forming the first plastic hinge (in.) (2.5)
- $\Delta_C$  = displacement capacity determined by using a static push over analysis in which both material and geometric non-linearities are considered (in.) (2.6.1)
- $\Delta_D$  = displacement demand determined by analysis methods specified in Article 3.1 under the *DSH* (in.) (2.6.1)



## CHAPTER 1

### INTRODUCTION

This chapter states the scope of the *Specifications* and summarizes referenced specifications and standards.

#### 1.1 SCOPE

The *Caltrans Seismic Design Specifications for Steel Bridges*, hereinafter referred to as the *Specifications*, specifies the design provisions for structural steel components in the *Earthquake Resisting Systems for Ordinary* steel bridges. The *Specifications* are supplemental to the *Caltrans Seismic Design Criteria* (Caltrans, 2013), hereinafter referred to as the *SDC*. The *SDC* shall apply to the design of components not explicitly addressed by the *Specifications* in the *Earthquake Resisting Systems for Ordinary Standard* steel bridges.

Provisions for steel substructures shall apply to the seismic design of existing or temporary bridges.

Provisions for Functional Evaluation Earthquake (*FEE*) shall apply only when they are established through the project-specific seismic design criteria.

The *Specifications* shall be applied in conjunction with the *AASHTO LRFD Bridge Design Specifications* (AASHTO, 2012), hereinafter referred to as the *AASHTO BDS*, and with the *California Amendments to the AASHTO LRFD Bridge Design Specifications – Sixth Edition* (Caltrans, 2014a), hereinafter referred to as the *Amendments*.

The Commentary provides background information about the development of the *Specifications*.

The *Specifications* include the Definitions, the Notation, Chapters 1 through 7, Appendices A through F, and Commentary.

#### C1.1

The term “shall” denotes a requirement for compliance with the *Specifications*.

The term “should” indicates a strong preference for a given criterion.

The terms “may” and “can” indicate a criterion that is usable, but other suitably documented, verified, and approved criterion may also be used in a manner consistent with the *Specifications* approach to steel bridge design.



## 1.2 REFERENCED SPECIFICATIONS AND STANDARDS

The following documents are referenced in the *Specifications*:

AASHTO. (2014). *Guide Specifications for Seismic Isolation Design*, 4<sup>th</sup> Edition.

AASHTO. (2012). *AASHTO LRFD Bridge Design Specifications*, US Customary Units, 2012, (6<sup>th</sup> Edition).

AASHTO. (2011). *AASHTO Guide Specifications for LRFD Seismic Bridge Design*, 2<sup>nd</sup> Edition.

ACI. (2014). *Building Code Requirements for Structural Concrete (ACI 318-14) and Commentary*.

AISC. (2010a). *Seismic Provisions for Structural Steel Buildings*, ANSI/AISC 341-10.

AISC. (2010b). *Specification for Structural Steel Buildings*, ANSI/AISC 360-10.

AISC. (2010c). *Code of Standard Practice for Steel Buildings and Bridges*, AISC 303-10.

Caltrans. (2015). *Standard Specifications 2015*.

Caltrans. (2014a). *California Amendments to the AASHTO LRFD Bridge Design Specifications- Sixth Edition*.

Caltrans. (2014b). *Bridge Memo to Designers Manual*.

Caltrans. (2013). *Caltrans Seismic Design Criteria*, Version 1.7.



## CHAPTER 2

### GENERAL PROVISIONS

This chapter addresses general provisions applicable to all chapters of the *Specifications*.

#### 2.1 BRIDGE CATEGORIES

*Ordinary* steel bridges shall be categorized as either *Standard* or *Non-standard* as shown in Table 2.1-1 and in accordance with Article 1.1 of the *SDC*.

#### 2.2 SEISMIC DEMANDS

*Ordinary* steel bridges shall be designed on the basis of the Safety Evaluation Earthquake (*SEE*), i.e., the Design Seismic Hazard (*DSH*) represented by the Design Spectrum (*DS*) as specified in Article 2.1 of the *SDC*. Unless otherwise specified in the *Specifications*, seismic demands shall be determined in accordance with Section 2 of the *SDC*.

#### 2.3 EARTHQUAKE RESISTING SYSTEMS AND STRUCTURAL COMPONENT CLASSIFICATION

Earthquake Resisting Systems (*ERS*) for *Ordinary* steel bridges are listed in Table 2.1-1. Structural components in *ERS* of a steel bridge shall be classified into two categories: Ductile and Capacity-Protected as shown in Table 2.1-1. Ductile components for an *Ordinary Standard* bridge shall be as specified in Article 3.1.1 of the *SDC*.

The use of steel substructures, buckling-restrained braces, and seismic isolation bearings for new bridges shall be approved by Caltrans through the type selection process. The ductile end cross frames (*DECF*) shall be permitted only for existing bridges through the retrofit strategy meeting.

#### C2.3

Ductile or seismic-critical components are those expected to experience significant damage, but not to fail, under the demands generated by the *DSH*. The ductile components are pre-identified and well-detailed to behave inelastically for several cycles without significant degradation of strength or stiffness. Capacity-protected components are those expected to experience minimum damage, and to behave essentially elastic under the *DSH*. Table 2.1-1 summarizes the structural component classification for *Ordinary* steel bridges.



SPECIFICATIONS

Table 2.1-1 Structural Component Classification for *Ordinary* Steel Bridges

Bridge Category	Direction	Earthquake Resisting System		Component Classification	
				Ductile	Capacity-Protected
<i>Standard</i>	<b>Longitudinal and Transverse</b>	Ductile Concrete Substructures		Columns; Type I shafts; Type II shafts and Pile/Shaft groups in soft or liquefiable soils; Piers about weak axis	Bent caps; Superstructures; Footings, Type II shafts and Pile/Shaft groups in competent soils
<i>Non-Standard</i>	<b>Longitudinal</b>	Ductile Steel Substructures		Same as the Transverse Direction	Same as the Transverse Direction
		Seismic Isolation		Isolation bearings	Bent caps; Superstructures; Substructures; Foundations
	<b>Transverse</b>	Seismic Isolation		Isolation bearings	Bent caps; Superstructures; Substructures; Foundations
		Ductile End Cross Frames (DECF)	Concentrically Braced Frames (CBF)	Bracing members	Bracing connections; Girders; Bent Cap; Substructures; Foundations
			Eccentrically Braced Frames (EBF)	Links	Braces; Bracing connections; Beam outside of links; Girders; Bent caps; Substructures; Foundations
		Ductile Steel Substructures	Moment Frames (MF)	Columns	Bent caps; Superstructures; Connections; Foundations
			Eccentrically Braced Frames (EBF)	Links	Bent caps; Superstructures; Braces; Beam outside of Links; Connections; Columns; Foundations
			Concentrically Braced Frames (CBF)	Bracing members	Superstructures Bracing connections Beams, Columns Foundations

Note: For *Ordinary Standard* steel bridges, abutment backwalls may be classified as ductile components.

**2.4 MATERIALS**

Structural steel used in capacity-protected components shall satisfy the requirements specified in Article 6.4.1 of the *AASHTO BDS*. Structural steel used in ductile components in the *ERS* shall satisfy one of the following standards:

- ASTM A709 Grade 50 and Grade 50W
- ASTM A992
- ASTM A500 Grade B
- ASTM A501 Grade B
- ASTM A1085

Other steels may be used, provided that they are compatible with the approved ASTM A709 Grade 50 steels. The specified minimum yield strength of steel used for ductile components shall not exceed 50 ksi unless the suitability of the material is determined by testing.

ASTM A709 Grade 36 or ASTM A36 may be used in brace members of a *DECF*. Other steels and nonsteel materials may be used in buckling-restrained braces subjected to the requirements of Article 5.4.

Structural steel used in ductile components shall satisfy the Charpy V-notch impact energy requirements in accordance with values for fracture-critical members as specified in Table 6.6.2-2 of the *AASHTO BDS*.

The expected yield strength  $F_{ye}$  of steel is defined as:

$$F_{ye} = R_y F_y \tag{2.4-1}$$

where

$F_y$  = specified minimum yield strength of steel (ksi)

$F_{ye}$  = expected yield strength of steel (ksi)

$R_y$  = ratio of the expected yield strength to the specified minimum yield strength

The expected tensile strength  $F_{ue}$  of steel is defined as:

$$F_{ue} = R_t F_u \tag{2.4-2}$$

**C2.4**

ASTM A709 Grade 50 and Grade 50W, A992, A550 Grade B, A501 Grade B specified herein are recommended in the *AASHTO Guide Specifications for LRFD Seismic Bridge Design* (AASHTO, 2011). ASTM A1085 is a newer specification published in 2013. It was developed specifically for structural steel applications using Hollow Structural Sections (HSS), and essentially ensures tighter tolerances than ASTM A500, includes Charpy V-notch requirements, and defines the maximum and the minimum yield stresses.

The *AISC Seismic Provisions* (AISC, 2010a) specify that structural steel permitted for use in ductile components are required to meet the following characteristics: (1) a pronounced stress-strain plateau at the yield strength; (2) a large inelastic strain capacity (for example, tensile elongation of 20 percent or greater in a 2 in. gage length); and (3) good weldability. Steel with a ratio of yield strength to tensile strength not greater than 0.85 is preferred. Ductile end cross frames using ASTM 709 Grade 36 performed well in experimental investigations (Carden et al., 2006b; Bahrami et al., 2010).



where

$F_u$  = specified minimum tensile strength of steel (ksi)

$F_{ue}$  = expected tensile strength of steel (ksi)

$R_t$  = ratio of the expected tensile strength to the specified minimum tensile strength

The values of  $R_y$  and of  $R_t$  are given in Table 2.4-1.

**Table 2.4-1  $R_y$  and  $R_t$  Values**

Application	$R_y$	$R_t$
Plate and all other products		
ASTM A709 Grade 36, A36	1.3	1.2
ASTM A709 Grade 50	1.1	1.2
Hot-rolled structural shapes and bars		
ASTM A709 Grade 36, A36	1.5	1.2
ASTM A709 Grade 50, A992	1.1	1.1
Hollow structural sections (HSS)		
ASTM A500 Grade B	1.4	1.3
ASTM A501 Grade B	1.4	1.3
ASTM A1085	1.2	1.1
	5	5
Pipe		
ASTM A53	1.6	1.2

The values of  $R_y$  and of  $R_t$  for various steel except ASTM A1085 given in Table 2.4-1 are recommended in the *AISC Seismic Provisions* (AISC, 2010a).  $R_y$  and of  $R_t$  for ASTM A1085 is recommended in the Draft of 2016 *AISC Seismic Provisions* (AISC, 2015).

## 2.5 DAMAGE LEVELS, STRAINS AND DUCTILITY IN STRUCTURAL STEEL

The limiting strains and ductility corresponding to damage levels are shown in Table 2.5-1. The limiting values for the significant damage level shall apply to ductile components under the *DSH*. The limiting values for the minimum damage level shall apply to capacity-protected components under the *DSH*.

The limiting values for the repairable damage level may apply to ductile components under the *FEE*.

## C2.5

Table 2.5-1 recommends quantitative strain and ductility limits for structural steel corresponding to the three damage levels specified in the Caltrans Seismic Performance Criteria in *MTD 20-1* (Caltrans, 2010).

SPECIFICATIONS

COMMENTARY

**Table 2.5-1 Damage Levels, Strain and Ductility in Structural Steel**

Damage Level	Strain	Ductility	
	$\epsilon_s$	$\mu_\theta$	$\mu_\Delta$
Significant	Lesser of <sup>[a]</sup> $\left\{ \begin{array}{l} 0.06 \\ \epsilon_{ue}/2 \end{array} \right.$	8	4
Repairable	Lesser of $\left\{ \begin{array}{l} 0.008 \\ 2\epsilon_{sh}/3 \end{array} \right.$	6	3
Minimal	Larger of $\left\{ \begin{array}{l} 0.003 \\ 1.5\epsilon_{ye} \end{array} \right.$	2	1.5
<sup>[a]</sup> For diagonal braces, limiting strain = Lesser of $\left\{ \begin{array}{l} 0.03 \\ 2\epsilon_{sh} \end{array} \right.$			

where

- $\epsilon_s$  = strain in steel
- $\epsilon_{sh}$  = strain at the onset of strain hardening of steel
- $\epsilon_{ye}$  = strain corresponding to the expected yield strength of steel
- $\epsilon_{ue}$  = strain corresponding to the expected tensile strength of steel
- $\mu_\Delta$  = displacement ductility, ratio of ultimate-to-yield displacement ( $\Delta_u/\Delta_y$ )
- $\mu_\theta$  = rotation ductility, ratio of ultimate-to-yield rotation ( $\theta_u/\theta_y$ )
- $\Delta_y$  = yield displacement, the lateral displacement of a component or a system at the onset of forming the first plastic hinge (in.)
- $\theta_y$  = yield rotation, rotation corresponding to the onset of yielding in the extreme tension fiber
- $\Delta_u$  = ultimate displacement capacity, the lateral displacement of a component or a system corresponding to its expected damage level limit as specified in Table 2.5-1, not to exceed that displacement when the lateral resistance degrades towards a minimum of 80 percent of the peak resistance (in.)
- $\theta_u$  = ultimate rotation capacity, rotation corresponding to its expected damage level at which the extreme fiber reaches its strain limit as specified in Table 2.5-1, not to exceed that rotation when the moment resistance degrades towards a minimum of 80 percent of the peak moment resistance

Figure C2.5-1 shows a typical stress-strain curve for structural steel under a monotonic loading. Appendix A presents stress-strain relationships of structural steel for the use in a seismic analysis.

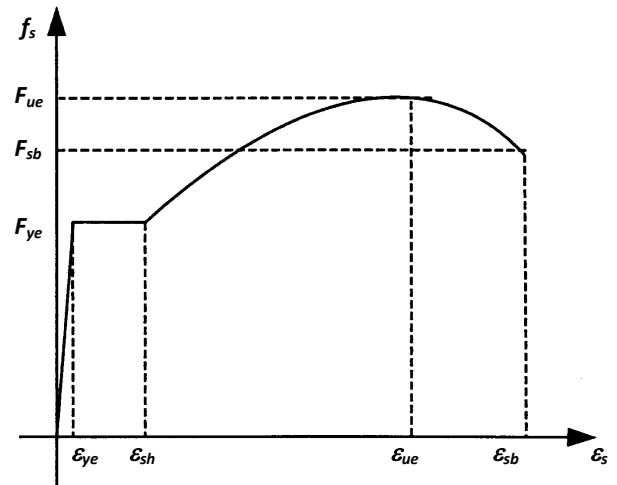
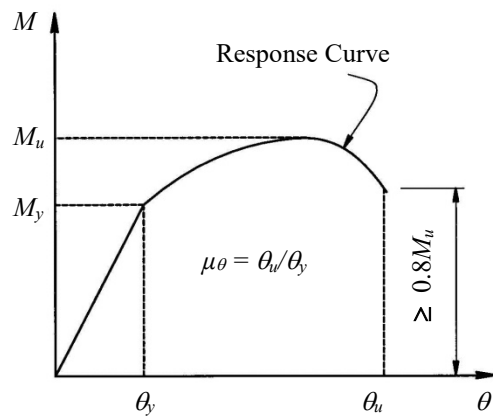

**Figure C2.5-1 Typical Stress-Strain Curve for Structural Steel**

where

- $\epsilon_{sb}$  = rupture strain of steel
- $F_{sb}$  = rupture stress of steel (ksi)
- $f_s$  = stress in steel (ksi)

Figure C2.5-2 shows schematic load-deformation curves.



(a) Moment-Rotation Curve

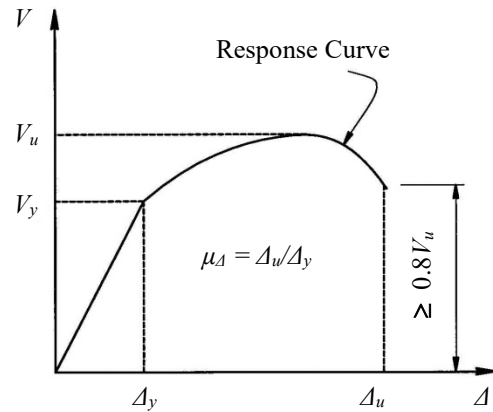

(b) Lateral Load-Displacement Curve

**Figure C2.5-2 Schematic Load-Deformation Curves**

where

- $M_u$  = peak moment or ultimate moment (kip-in.)
- $M_y$  = yield moment (kip-in.)
- $V_u$  = peak lateral load or ultimate lateral load capacity (kip)
- $V_y$  = lateral force corresponding to the onset of forming the first plastic hinge (kip)

## 2.6 DESIGN BASIS

### 2.6.1 Displacements

Displacement ductility demands as specified in Article 2.2.3 of the *SDC* and target displacement ductility demand specified in Article 2.2.4 of the *SDC* shall apply.

The displacements in a global and local ductile system shall satisfy:

$$\Delta_D \leq \Delta_C \quad (2.6.1-1)$$

where

$\Delta_D$  = displacement demand determined by analysis methods specified in Article 3.1 under the *DSH* (in.)

$\Delta_C$  = displacement capacity determined by using a static push over analysis in which both material and geometric non-linearities are considered (in.)

#### C2.6.1

Displacement-based design approach is applicable when the fundamental period is larger than 0.5 sec. (Chopra, 2011).

### 2.6.2 Forces

The forces in a capacity-protected component shall satisfy:

$$F_D \leq F_C \quad (2.6.2-1)$$

where

$F_D$  = force demand (axial/shear force, and moment as appropriate) on a capacity-protected component determined by the overstrength forces of adjacent ductile components

$F_C$  = design strength, or factored resistance (axial/shear force and moment as appropriate) of a capacity-protected component

For a truss bridge supported on ductile substructures, force demands on the truss members shall be determined based on the overstrength forces of the substructure.

For a truss bridge supported on seismic isolation bearings, force demands on the truss members shall be determined based on the maximum forces allowed to be transferred by the isolators.

For a slab-on-steel girder bridge, force demands on the superstructures shall be determined in accordance with Chapter 6.

### 2.6.3 Overstrength

The overstrength force of a ductile component shall be taken as its idealized plastic strength multiplied by an overstrength factor,  $\Omega$ , determined by the project specific criteria.

### C2.6.3

Overstrength factors are used to primarily account for material strength variation between the ductile components and adjacent members, and the potential overstrength of the idealized plastic strength of a ductile component. Upon the need to determine the overstrength factor,  $\Omega$ , for the project specific criteria, the research should be reviewed and testing, if needed, should be performed.

McDaniel et al. (2002), and Dusicka et al. (2002 and 2010) performed the proof testing for I-shaped shear links used in the new San Francisco-Oakland Bay Bridge. Berman and Bruneau (2008) conducted testing for box-shaped shear links for eccentrically braced frames. Bahrami, et al. (2010) reported testing for single and double angle braces in the ductile end cross frames.

### 2.6.4 Design Strength

The design strength (axial, shear and flexural) of a capacity-protected component shall be taken as its expected nominal strength multiplied by a resistance factor,  $\phi$ , as follows:

- For tension, fracture in the net section  
$$\phi_t = 0.90$$
- For bolts and welds  
$$\phi = 0.90$$
- For block shear  
$$\phi_{bs} = 0.90$$
- For shear connector  
$$\phi = 0.95$$
- For all other cases  
$$\phi = 1.00$$

### 2.6.5 Expected Nominal Strength

The expected nominal strength shall be taken as the nominal strength based on the expected material properties,  $F_{ye}$  and  $F_{ue}$ , as specified in the *Specifications*.

### 2.6.6 Idealized Plastic Strength

The idealized plastic strength shall be taken as the expected nominal strength multiplied by a factor 1.17.

### C2.6.4

Resistance factors for seismic design are increased approximately 10 percent above those for strength limit state as specified in Article 6.5.4.2 of the *AASHTO BDS*.

### C2.6.6

The 1.17 factor in the idealized plastic strength accounts for the strain hardening at the significant damage level specified in Article 2.5.

## CHAPTER 3 STRUCTURAL ANALYSIS

This chapter addresses analysis requirements for seismic design of steel bridges.

### 3.1 ANALYSIS METHODS

#### 3.1.1 General

Equivalent Static Analysis (*ESA*) as specified in Article 5.2.1 of the *SDC*, or Elastic Dynamic Analysis (*EDA*) as specified in Article 5.2.2 of the *SDC* shall be used to determine displacement demands for a steel bridge. Inelastic Static Analysis (*ISA*) as specified in Article 5.2.3 of the *SDC* shall be used to determine displacement capacities of a steel bridge.

#### C3.1.1

Inelastic Static Analysis (*ISA*), commonly referred to as the “push over” analysis, is used to determine the displacement capacity of a steel bridge (Akkari and Duan, 2014). *ISA* can be categorized into three types of analysis: (1) elasto-plastic hinge, (2) refined plastic hinge, and (3) distributed plasticity.

The simplest method, elasto-plastic hinge analysis, can be used to obtain an upper bound solution. Refined plastic hinge analysis is a compromise that can reasonably achieve both computational efficiency and accuracy. The most accurate method, distributed plasticity analysis, can be used to obtain the best solution.

In an elasto-plastic hinge (lumped plasticity) analysis, material inelasticity is taken into account using concentrated “zero-length” plastic hinges which maintain plastic moment capacities and rotate freely. When the section reaches its plastic moment capacity, a plastic hinge is formed and element stiffness is adjusted (King et al., 1992; Levy et al., 1997). For regions in a framed member away from the plastic hinge, elastic behavior is assumed. It does not, however, accurately represent the distributed plasticity and associated  $P$ - $\delta$  effects. This analysis provides an upper bound solution.

In a refined plastic hinge analysis (Chen and Toma, 1994), a two-surface yield model considers the reduction of plastic moment capacity at the plastic hinge due to the presence of axial force, and an effective tangent modulus accounts for the stiffness degradation due to distributed plasticity along a frame member. This analysis is similar to the elasto-plastic hinge analysis in efficiency and simplicity and also accounts for distributed plasticity.

### 3.1.2 Moment-Curvature Analysis

In a moment-curvature analysis for a ductile structural steel section, the following assumptions are usually made:

- Section that is plane before bending remains plane after bending.
- Shear and torsional deformation are negligible.
- Stress-strain relationships for steel are known.

For a slender compression element, its area shall be modified by the slender element reduction factor,  $Q$ , as specified in Article 6.9.4.2.2 of the *AASHTO BDS*.

Distributed plasticity analysis models the spread of inelasticity through the cross sections and along the length of the members. This is also referred to as plastic zone analysis, spread-of-plasticity analysis, or elasto-plastic analysis by various researchers. In this analysis, a member needs to be subdivided into several elements along its length to model the inelastic behavior more accurately. Two main approaches have been successfully used to model plastification of members in a distributed plasticity analysis:

- Cross sectional behavior is described as an input for the analysis by means of moment-thrust-curvature ( $M-P-\phi$ ) and moment-thrust-axial strain ( $M-P-\varepsilon$ ) relations, which may be obtained separately from a moment-curvature analysis or approximated by closed-form expressions (Chen and Atsuta, 1977).
- Cross sections are subdivided into elementary areas and the state of stresses and strains are traced explicitly using the proper stress-strain relations for all elements during the analysis.

### C3.1.2

The moment-curvature analysis is a part of *ISA*. Moment-curvature relationships are basic input parameters for *ISA*.

The slender element reduction factor is used to consider the local buckling effects.

### 3.1.3 Displacement Magnification for Short-Period Structures

The displacement demand,  $\Delta_D$ , calculated from *ESA* or *EDA* shall be multiplied by the magnification factor  $R_d$  as follows:

$$R_d = \begin{cases} 1.0 & \text{for } \frac{T^*}{T} \leq 1.0 \\ \left(1 - \frac{1}{\mu_D}\right) \frac{T^*}{T} + \frac{1}{\mu_{DL}} \geq 1.0 & \text{for } \frac{T^*}{T} > 1.0 \end{cases} \quad (3.1.3-1)$$

$$T^* = 1.25 \left( \frac{S_{D1}}{S_{DS}} \right) \quad (3.1.3-2)$$

where

- $T$  = fundamental period of the structure (sec.)
- $S_{D1}$  = *DS* acceleration coefficient at 1.0-sec
- $S_{DS}$  = *DS* acceleration coefficient at 0.2-sec
- $\mu_{DL}$  = maximum local member displacement ductility demand. In lieu of a detailed analysis, it may be taken as 6.

## 3.2 STRUCTURAL MODELING

### 3.2.1 General

The modeling principles presented in Articles 5.3, 5.4, and 5.5 of the *SDC* shall generally apply. The steel girder and truss superstructure should be modeled as a series of three-dimensional frame elements. Bent caps and columns shall be modeled as three-dimensional frame elements.

The modeling principles for abutments presented in Articles 7.8.1 and 7.8.2 of the *SDC* shall apply.

### C3.1.3

The assumption that displacements of an elastic system will be the same as those of an elasto-plastic system is not valid for short-period structures that are expected to perform inelastically. The magnification factor,  $R_d$ , is used to correct the displacement determined from an elastic analysis for short-period structures. Equation (3.1.3-1) is recommended in Article 4.3.3 of the *AASHTO Guide Specifications for LRFD Seismic Bridge Design* (AASHTO, 2011)

### C3.2.1

In general, dynamic behavior of a bridge structure can be predicted by the finite element method. The elements can be frame (beam), shell, solid elements or other types of elements idealizing the real structures. Two types of finite element models, simplified and detailed, are typically used for dynamic analysis of a steel bridge structure. A simplified model uses two-dimensional or three-dimensional frame elements, in so-called “stick” models to represent superstructures and columns. A detailed model uses solid elements for superstructure deck, shell elements for steel girders, and frame elements for columns.

The dynamic characteristics of straight steel girder bridges can be captured by the simplified modeling procedure (Itani and Sedarat, 2000). The five elements per span are sufficient for a good representation of the first three vibration modes of a span (ATC, 1996).



Elastomeric bearings should be modeled as spring link elements based on bearing properties. Vertical, lateral and rotational stiffness of bearings shall be obtained by testing or provided by bearing manufacturers. Effective lateral stiffness may be used to consider nonlinear behavior of bearings and the close of the gap. The space between the bearings and shear keys should be modeled as a gap element.

Anchorage of bearings should be modeled as spring systems that include springs to simulate the tension deformation in anchor bolts, and springs to simulate the compression deformation in concrete under the base plate. Each of these springs shall be characterized by its own load-deformation relationship as an individual component. Shear keys at intermediate bent supports shall be modeled as rigid elements. Shear keys at abutments shall be modeled in accordance with Article 7.8 of the *SDC*. Elastomeric bearings without shear keys should be modeled as spring elements allowing the bridge to move when their maximum displacement capacities are reached.

### 3.2.2 Materials

Structural steel shall be modeled to closely represent actual testing behavior. In the absence of material data and test results, the stress-strain relationships for structural steel provided in Appendix A shall be used in the analysis.

Kinematic and isotropic strain hardening characteristics of *BRB* shall include effects of the intended yielding core material observed from cyclic testing.

When the periods of the higher modes of a span are within the acceleration-control region of the earthquake response spectrum, it is necessary to include more elements to capture high modes. In general, if the contribution of the *i*th mode needs to be included in the analysis, the spans should be modeled by  $2i-1$  elements over the span length (Itani and Sedarat, 2000).

### C3.2.2

Strain hardening will increase the forces developed in *BRB*, thus increase the seismic force demands imposed to the adjoining connections and elements. Kinematic hardening is typically and simply accounted for when modeling *BRB* in finite element analysis. As demonstrated by Lanning et al. (2013), however, sufficient characterization of isotropic hardening is required to simulate actual *BRB* responses, especially for certain materials such as stainless steel.

## SPECIFICATIONS

## COMMENTARY

**3.2.3 Geometry**

Both  $P-\Delta$  and  $P-\delta$  effects shall be considered in the determination of displacement demands and capacities.

The  $P-\Delta$  effect can be ignored when the following equation is satisfied:

$$P_{dl} \Delta_{r1} \leq 0.1M_1 \quad (3.2.3-1)$$

where

$P_{dl}$  = axial dead load in the column (kip)

$\Delta_{r1}$  = relative lateral displacement demand between the point of contra-flexure and the end of column based on the first-order analysis under the *DSH* (in.)

$M_1$  = end moment demand of a column based on the first-order analysis under the *DSH* (kip-in.)

**3.2.4 Initial Imperfection**

Initial imperfections, a member out-of-straightness equal to  $L_b/1000$ , where  $L_b$  is the member length between brace or framing point, and a frame out-of-plumbness equal to  $H/500$ , where  $H$  is the distance between working points, shall be considered in the *ISA*.

## C3.2.3

The second-order effects including both  $P-\Delta$  and  $P-\delta$  effects can be evaluated by a large deflection analysis, usually referred to as second-order analysis or geometrically nonlinear analysis where equilibrium equations are established with respect to the deformed geometry of the structure. The  $P-\Delta$  effect is the effect of axial loads acting on the deformed locations of joints or nodes in a structure. The  $P-\delta$  effect is the effect of axial loads acting on the deflected shape of a member between joints and nodes.

A small deflection analysis is usually referred to as first-order analysis or geometrically linear analysis where equilibrium equations are established with respect to undeformed (or original) geometry of the structure. It is recognized that a first-order analysis always underestimates the force and deformation effects.

Steel structures are usually more slender and flexible and sensitive to the  $P-\Delta$  effect than concrete structures. More stringent requirements are specified herein to ensure that structural stability is considered in the determination of displacement demands and capacities. The *ASCE Minimum Design Loads for Buildings and Other Structures* (ASCE, 2010) specifies that  $P-\Delta$  effects need not be considered when the ratio of the secondary moment to the primary moment does not exceed 0.10.

## C3.2.4

Initial imperfections are conservatively taken as the maximum material, fabrication and erection tolerance permitted in Article 7.13 in the *AISC Code of Standard Practice for Steel Buildings and Bridges* (AISC, 2010c).

### 3.2.5 Effective Section Properties

Effective stiffness,  $(EI)_{eff}$  shall be used for ductile members to determine the structure's period and displacement demands by *ESA* and *EDA* analyses under the *DSH*:

$$(EI)_{eff} = 0.8\alpha_p EI \quad (3.2.5-1)$$

where

- $E$  = modulus of elasticity of steel  
= 29,000 ksi
- $I$  = moment of inertia of a steel section in the plane of bending (in.<sup>4</sup>)

$\alpha_p$  = stiffness reduction factor

$$\alpha_p = \begin{cases} 1.0 & \text{for } P_u / P_y \leq 0.5 \\ 4(P_u / P_y)(1 - P_u / P_y) & \text{for } P_u / P_y > 0.5 \end{cases} \quad (3.2.5-2)$$

where

- $P_u$  = axial force due to seismic and permanent loads (kip)
- $P_y$  = axial yield strength of a steel section ( $A_g F_y$ ) (kip)
- $A_g$  = gross cross-sectional area (in.<sup>2</sup>)

For latticed members, effective section properties provided in Appendix B should be used in lieu of a refined analysis.

For buckling-restrained braces (*BRB*), effective axial stiffness shall account for the yielding core, stiffened extended core, and connection portions of the brace. It shall be determined by the testing or provided by *BRB* manufacturers.

The post-yield stiffness shall reasonably account for *BRB* force-displacement behavior from testing.

The lateral stiffness for a steel girder bridge at the bent in the transverse direction as presented in Appendix D may be used to estimate the period of fundamental mode of vibration in the transverse direction.

### C3.2.5

The use of effective section properties, such as effective moment inertia,  $I_{eff}$  and  $J_{eff}$  for concrete ductile members are required for seismic analysis as specified in Article 5.6 of the *SDC*.

Effective stiffness of steel members is used to consider the elastic stability effects for frames with slender members and partial yielding accentuated by residual stresses in steel members. The 0.8 factor is used to consider the slender member effects on the elastic stability and the  $\alpha_p$  factor reduces the flexural stiffness to account for inelastic softening prior to the members reaching their design capacities (AISC, 2010b).

The effective section properties are to consider the actual section integrity for latticed members (Duan et al., 2000).

For *BRB*, post-yielding stiffness is usually 1% to 3.5% of the elastic stiffness (Sabelli et al. 2003; Black et al., 2004).

SPECIFICATIONS

COMMENTARY

For single angle brace members, the following effective area  $(A_L)_{eff}$  should be used in lieu of a refined analysis.

$$(A_L)_{eff} = \left( \frac{1}{1 + 0.8\gamma} \right) A_L \quad (3.2.5-3)$$

$$\gamma = \frac{1}{\frac{I_g L_L}{2I_L L_g} + 1} \quad (3.2.5-4)$$

where

- $A_L$  = cross-sectional area of an angle (in.<sup>2</sup>)
- $L_g$  = distance between the edge of the connecting angle and the end of a gusset plate (in.)
- $L_L$  = length of an angle (in.)
- $I_g$  = moment of inertia of a gusset plate in the plane of bending (in.<sup>4</sup>)
- $I_L$  = moment of inertia of an angle in the plane of bending (in.<sup>4</sup>)

**3.3 EFFECTIVE LENGTH OF COMPRESSION MEMBERS**

In the absence of more accurate analysis, the effective length factor  $K$  of compression members in the plane of buckling may be determined in accordance with Article 4.6.2.5 of the *AASHTO BDS* and the *Amendments*.

For built-up members, if the buckling mode involves relative deformations that produce shear forces in the connectors between individual shapes, the effective slenderness ratios shall be modified in accordance with Article 6.9.4.3 of the *AASHTO BDS*.

For diagonals in an X-bracing system, when the diagonals are continuous and attached at the intersection point, the effective length factor  $K$  may be taken equal to 0.5. For X-bracing systems made of single equal-leg angles attached at the intersection point, the effective length factor  $K$  may be taken equal to 0.425. Unbraced length of diagonals shall be taken as the distance between the working points.

For single angle members, the effective length factor may be determined in accordance with Article 6.9.4.4 of the *AASHTO BDS*.

Single angles are connected to the gusset plates with eccentricity. Axial stiffness is reduced significantly due to bending effects of end connection eccentricities. Effective axial stiffness Equation (3.2.5-3) is recommended by Wang (2013).

C3.3

The effective length factor  $K$  plays an important role in compression member design. A comprehensive discussion can be found in Duan et al. (2014).

The  $K$  factor for diagonals in X-bracing systems is based on theoretical and experimental studies by Picard and Beaulieu (1987 and 1988). The  $K$  factor for single angle diagonals is based on the recommendation by El-Tayem and Goel (1986).

## CHAPTER 4

### DESIGN REQUIREMENTS

This chapter addresses general seismic design requirements for steel members and connections.

#### 4.1 PROPORTIONS

*ERS* for steel bridges shall be proportioned and designed to provide effective load path continuity, and to reduce the seismic demands and effects on the structural system to the greatest extent possible. The inertial forces generated by the deck shall be transferred to the substructure through girders, trusses, cross frames, lateral bracings, end diaphragms and bearings. Steel components within the *ERS* shall be designed to achieve their desired performance.

At transition and splice locations of a ductile member, the ratio of the larger stiffness to the smaller stiffness, and the ratio of the larger strength to the smaller strength shall not exceed 1.5.

#### 4.2 LIMITING WIDTH-TO-THICKNESS RATIOS

For ductile components, width-to-thickness ratios of elements shall not exceed the limiting values,  $\lambda_{ps}$ , as specified in Tables 4.2-1 to 4.2-3.

For capacity-protected components, width-to-thickness ratios of elements shall not exceed the limiting values,  $\lambda_r$ , as specified in Tables 4.2-1 and 4.2-3.

#### C4.1

For steel bridges, structural components are generally designed to ensure that inelastic deformation occurs in the specially detailed ductile substructure elements. Inelastic behavior in the form of controlled damage may be permitted in some of the superstructure components such as the end cross-frames and isolation bearings.

#### C4.2

To ensure that reliable inelastic deformations can be achieved in ductile components, the width-to-thickness ratios of elements are required to not exceed the limiting values specified in Tables 4.2-1 to 4.2-3. The limiting width-to-thickness ratio of elements for ductile components,  $\lambda_{ps}$ , correspond to  $\lambda_{hd}$  for highly ductile members in the *AISC Seismic Provisions* (2010a) and are deemed adequate for large ductility demands without local buckling under the *DSH*. Limiting width-to-thickness ratios for links for the eccentrically braced frames specified in Table 4.2-2 are recommended by Bruneau (2013). The limiting width-to-thickness ratio of elements for capacity-protected components,  $\lambda_r$ , correspond to limits for noncompact/slender elements given in the *AISC Specifications* (AISC, 2010b). Limiting width-to-thickness ratios given in Tables 4.2-1 and 4.2-3 are based on Caltrans seismic retrofit practice (Caltrans, 1997 and 2001), Table D1.1 of the *AISC Seismic Provisions* (AISC, 2010a) and Table B4.1 of the *AISC Specifications* (AISC, 2010b).

## SPECIFICATIONS

**Table 4.2-1 Limiting Width-to-Thickness Ratios for Unstiffened Compression Elements**

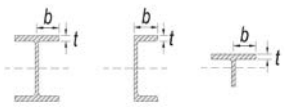
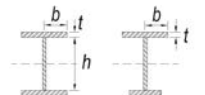
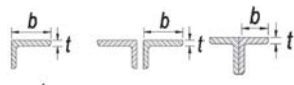
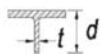
No	Description of Elements	Examples	Width-to-Thickness Ratio	Limiting Width-to-Thickness Ratio		
				Ductile Component	Capacity-Protected Component	
					Axial Compression <sup>[d]</sup>	Flexure
$\lambda_{ps}$	$\lambda_r$	$\lambda_r$				
1	Flanges of rolled I-shaped sections, channels and tees		$b/t$	$0.30 \sqrt{\frac{E}{F_y}}$	$0.56 \sqrt{\frac{E}{F_y}}$	$1.00 \sqrt{\frac{E}{F_y}}$
2	Flanges of built-up I-shaped sections		$b/t$	$0.30 \sqrt{\frac{E}{F_y}}$	$0.64 \sqrt{\frac{k_c E}{F_y}}^{[a]}$	$0.95 \sqrt{\frac{k_c E}{F_L}}^{[a][b]}$
3	Legs of single angles or double angle members with separators; outstanding legs of pairs of angles in continuous contact		$b/t$	$0.30 \sqrt{\frac{E}{F_y}}$	$0.45 \sqrt{\frac{E}{F_y}}$	$0.91 \sqrt{\frac{E}{F_y}}$
4	Stem of tees		$d/t$	$0.30 \sqrt{\frac{E}{F_y}}^{[c]}$	$0.75 \sqrt{\frac{E}{F_y}}$	$1.03 \sqrt{\frac{E}{F_y}}$

Notes:

[a].  $0.35 \leq k_c = 4/\sqrt{h/t_w} \leq 0.76$



[b].  $F_L = 0.7F_y$  for major axis bending of compact and noncompact web built-up I-shaped members with  $S_x/S_{sc} \geq 0.7$ ;  
 $F_L = 0.7F_y S_x/S_{sc} \geq 0.5F_y$  for major axis bending of compact and noncompact web built-up I-shaped members with  $S_x/S_{sc} < 0.7$ .

[c]. The stem of the tee can be increased to  $0.38 \sqrt{E/F_y}$  if either of the following conditions are satisfied:

- Buckling of the compression member occurs about the plane of the stem.
- The axial compression load is transferred at end connections to only the outside face of the flange of the tee resulting in an eccentric connection that reduces the compression stresses at the tip of the stem.

[d]. For member subjected to combined axial compression and flexure, when  $P_u/\phi_c P_y \leq 0.15$ , limiting values for flexural members shall be used.

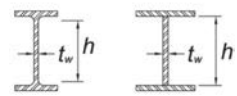
**Table 4.2-2 Limiting Width-to-Thickness Ratios for Links for Eccentrically Braced Frames**

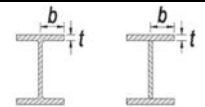
No	Description of Elements	Examples	Width-to-Thickness Ratio	Limiting Width-to-Thickness Ratio
				$\lambda_{ps}$
5	Webs of built-up box sections		$h/t_w$	$0.64 \sqrt{\frac{E}{F_y}}$
6	Webs of rolled or built-up I-shaped sections		$h/t_w$	$1.49 \sqrt{\frac{E}{F_y}}$
7	Flanges of built-up box sections		$b/t$	$0.64 \sqrt{\frac{E}{F_y}}$
8	Flanges of rolled or built-up I-shaped sections		$b/t$	$0.32 \sqrt{\frac{E}{F_y}}$

## SPECIFICATIONS

Table 4.2-3 Limiting Width-to-Thickness Ratios for Stiffened Compression Elements

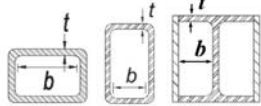
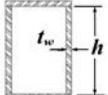
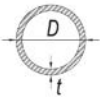
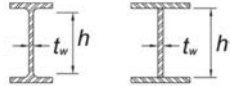
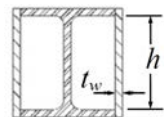
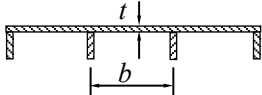
No	Description of Elements	Examples	Width-to-Thickness Ratio	Limiting Width-to-Thickness Ratio		
				Ductile Component	Capacity-Protected Component	
					Axial Compression <sup>[f]</sup>	Flexure
				$\lambda_{ps}$	$\lambda_r$	$\lambda_r$
9	Flanges of boxed I-shaped sections and built-up box sections; flanges of rectangular box sections		$b/t$	$0.60 \sqrt{\frac{E}{F_y}}^{[a]}$	$1.40 \sqrt{\frac{E}{F_y}}$	$1.40 \sqrt{\frac{E}{F_y}}$
10	Webs of rectangular HSS and built-up boxes		$h/t_w$	$0.60 \sqrt{\frac{E}{F_y}}$	$1.40 \sqrt{\frac{E}{F_y}}$	$5.70 \sqrt{\frac{E}{F_y}}$
11	Wall of round HSS		$D/t$	$^{[e]} 0.038 \frac{E}{F_y}$	$^{[e]} 0.11 \frac{E}{F_y}$	$0.31 \frac{E}{F_y}$
12	Webs of rolled or built-up I-shaped sections		$h/t_w$	$^{[b][c][d]} 2.45 \sqrt{\frac{E}{F_y}} \leq 2.59 \sqrt{\frac{E}{F_y}} (1 - 0.43C_a) \leq 1.49 \sqrt{\frac{E}{F_y}}$	$1.49 \sqrt{\frac{E}{F_y}}$	$5.70 \sqrt{\frac{E}{F_y}}$
13	Side plates of boxed I-shaped sections; Webs of built-up box sections		$h/t_w$	For $C_a \leq 0.125^{[a][c]}$ $2.45 \sqrt{\frac{E}{F_y}} (1 - 0.93C_a)$ For $C_a > 0.125$ $0.77 \sqrt{\frac{E}{F_y}} (2.93 - C_a) \geq 1.49 \sqrt{\frac{E}{F_y}}$	$1.49 \sqrt{\frac{E}{F_y}}$	$5.70 \sqrt{\frac{E}{F_y}}$
14	Longitudinally stiffened plates in compression of box sections		$b/t$	$0.44 \sqrt{\frac{kE}{F_y}}^{[g]}$	$0.66 \sqrt{\frac{kE}{F_y}}$	$0.66 \sqrt{\frac{kE}{F_y}}$

Notes:

[a]. For diagonal braces,  $\lambda_{ps} = 0.55 \sqrt{E/F_y}$ . [b]. For diagonal braces,  $\lambda_{ps} = 1.49 \sqrt{E/F_y}$ . [c].  $C_a = P_u / (\phi_c P_y)$

[d]. For webs of H-Pile sections,  $\lambda_{ps} = 0.94 \sqrt{E/F_y}$ .

[e]. For walls of concrete-filled round tubes,  $\lambda_{ps} = 0.076E/F_y$ ;  $\lambda_r = 0.15E/F_y$ .

[f]. For member subjected to combined axial compression and flexure, when  $P_u / \phi_c P_y \leq 0.15$ , limiting values for flexural members shall be used.

[g].  $k$  = plate buckling coefficient for uniform normal stress.

A value of  $k$  ranging from 2.0 to 4.0 generally should be assumed (AASHTO, 2012).

For  $n = 1$ ,  $k = (8I_s/bt^3)^{1/3}$ ; For  $n = 2$ ,  $k = (0.894I_s/bt^3)^{1/3}$ ,  $1.0 \leq k \leq 4.0$

$n$  = number of equally spaced longitudinal compression flange stiffeners

$I_s$  = moment of inertia of a longitudinal stiffener about an axis parallel to the bottom flange and taken at the base of the stiffener

### 4.3 LIMITING SLENDERNESS RATIOS

For ductile and capacity-protected components, the slenderness ratio,  $KL_b/r$  for compression members, and  $L_b/r_y$  for flexural members, shall not exceed the limiting values as specified in Table 4.3-1.

where

$K$  = effective length factor of a compression member in the plane of buckling

$L_b$  = unbraced length of a compression member (in.)

$r$  = radius of gyration about the axis perpendicular to the plan of the buckling (in.)

$r_y$  = radius of gyration about the minor axis (in.)

**Table 4.3-1 Limiting Slenderness Ratios**

Member	Slenderness Ratio	Limiting Slenderness Ratio	
		Ductile Component	Capacity-Protected Component
Columns	$KL_b/r$	$2.36\sqrt{E/F_y}$	$3.54\sqrt{E/F_y}$
Braces	$KL_b/r$	200	200
Flexural Members	$L_b/r_y$	$0.086E/F_y$	$0.17E/F_y$

### 4.4 PLASTIC REGIONS

Welds located in the plastic regions are preferably complete joint penetration welds. Partial penetration groove welds shall not be used in these regions.

The member flanges shall be continuously connected to the web(s).

### 4.5 MEMBER DESIGNATION

Plastic regions shall be designated as *Fracture Critical Members (FCM)* on design plans for the fabrication purpose only. The designation of *FCM* for the plastic regions shall not be tied to in-service inspection.

### C4.3

The symbol  $L_b$  in the slenderness ratio  $KL_b/r$  is the unbraced length of a compression member in the plane of buckling. The symbol  $L_b$  in  $L_b/r_y$  is the unbraced length of a flexural member in the plane perpendicular to the plane of bending under consideration.

The slenderness ( $KL_b/r$ ) limit of 200 for brace members in concentrically braced frames (*CBF*) is recommended in the *AISC Seismic Provisions* (AISC, 2010a). Research has shown that *CBF* with the slender braces designed for compression strength behaves well due to the overstrength inherent in their tension capacities (Tremblay, 2000; Tang and Goel, 1989; Goel and Lee, 1992; Bruneau, et al., 2011).

### C4.5

Fabrication of ductile components and their connections must be in compliance with Quality Control (QC) and Quality Assurance (QA) inspection procedures for *Fracture Critical Members* and *Main Tension Members* specified in the *Caltrans Standard Specifications* (Caltrans, 2015).



Ductile components outside the plastic regions and their connections shall be designated as *Main Tension Members* on design plans.

#### 4.6 SPECIAL BRACINGS AT PLASTIC HINGE LOCATIONS

Special bracings shall be provided adjacent to expected plastic hinge locations of columns as required in earthquake resisting systems. Bracing shall satisfy the following requirements:

- Both flanges of the member shall be laterally braced or the member cross section shall be torsionally braced.
- When lateral bracing is used, lateral bracing of each flange adjacent to plastic hinges shall be designed for the following lateral force:

$$P_{br} = \frac{0.06F_{ye}Z}{h_o} \quad (4.6-1)$$

where

- $h_o$  = distance between flange centroids (in.)
- $Z$  = plastic section modulus of a plastic hinge section in the plane of bending (in.<sup>3</sup>)

The lateral bracing shall have a minimum stiffness as follows:

$$\beta_{br} = \frac{10F_{ye}Z}{L_b h_o} \quad (4.6-2)$$

where

- $L_b$  = unbraced length of a member (in.)
- $\beta_{br}$  = minimum brace stiffness (kip/in.)

- When the torsional bracing is used, torsional bracing adjacent to plastic hinges shall be designed for the following moment:

$$M_{Tb} = 0.06F_{ye}Z \quad (4.6-3)$$

Torsional bracing can be provided with a moment-connected beam, cross frame, or diaphragm. It need not be attached near the compression flange (AISC, 2010b).

Torsional bracing shall have a minimum stiffness as follows:

#### C4.6

The requirements are based on the provisions specified in Chapter D of the *AISC Seismic Provisions* (AISC, 2010a).

SPECIFICATIONS

COMMENTARY

$$\beta_{Tb} = \frac{\beta_T}{\left(1 - \frac{\beta_T}{\beta_{sec}}\right)} \quad (4.6-4)$$

$$\beta_T = \frac{2.4L(F_{ye}Z)^2}{nEI_y C_b^2} \quad (4.6-5)$$

$$\beta_{sec} = \frac{3.3E^2}{h_o} \left( \frac{1.5h_o t_w^3}{12} + \frac{t_{st} b_s^3}{12} \right) \quad (4.6-6)$$

where

$C_b$  = lateral torsional buckling modification factor for nonuniform moment determined by Article 6.10.8.2.3 of the *AASHTO BDS*, for single curvature with one pin-end,  $C_b = 1.75$ ; for double curvature with equal end moments,  $C_b = 2.3$

$I_y$  = moment of inertia about the weak axis (in.<sup>4</sup>)

$L$  = length of member (in.)

$L_b$  = unbraced length of a member (in.)

$Z$  = plastic section modulus of a plastic hinge section in the plane of bending (in.<sup>3</sup>)

$I$  = moment of inertia of a steel section in the plane of bending (in.<sup>4</sup>)

$b_s$  = stiffener width for one-sided stiffener, twice the individual stiffener width for a pair of stiffeners (in.)

$n$  = number of lateral bracing points within the span

$t_w$  = thickness of member web (in.)

$t_{st}$  = thickness of web stiffener (in.)

$\beta_{sec}$  = web torsional stiffness, including the effects of web transverse stiffeners (kip-in./rad)

$\beta_T$  = overall brace system stiffness (kip-in./rad)

$\beta_{Tb}$  = minimum torsional stiffness (kip-in./rad)

## 4.7 STABILITY BRACINGS AT BEAM-TO-COLUMN CONNECTIONS

### 4.7.1 Braced Connections

The following requirements shall apply:

- Column flanges shall be laterally braced at the level of both the top and bottom flanges either directly or indirectly. Direct stability bracing of the column flange is achieved through use of member braces or other members attached to the column flange at or near the desired bracing point. Indirect stability bracing refers to bracing that is achieved through the stiffness of members and connections that act through the column web or stiffener plates.
- Each column flange member brace shall be designed for a lateral force of 2% of beam flange strength  $F_y b_f t_f$ , where  $b_f$  and  $t_f$  are beam flange width and thickness.

### 4.7.2 Unbraced Connections

For a beam-to-column connection with no member bracing transverse to the frame at the connection, the unbraced length of a column is the distance between adjacent member braces.

## 4.8 BUILT-UP MEMEBRS

Built-up members shall be designed in accordance with Article 6.9.4.3 of the *AASHTO BDS*. For existing structures, when the slenderness ratio of each component shape between the connectors is larger than 75 percent of the governing slenderness ratio of the built-up member as a whole unit, the buckling mode interaction factor,  $\beta$ , provided in Appendix E should be used to modify the effective length factor of the built-up member.

### C4.7.1

The columns of a moment frame (*MF*) are intentionally designed as ductile members and are required to be braced to prevent rotation out of the plane of the moment frame. The bracing requirements are based on provisions for inelastic columns outside the panel zone in Chapter E of the *AISC Seismic Provisions* (AISC, 2010a).

### C4.8

The compressive strength of built-up members is affected by the compound buckling due to the interaction between the global buckling mode of the member and the localized flange component buckling mode between lacing points or intermediate connectors. The  $\frac{3}{4}(KL/r)$  rule for latticed members is recommended to effectively mitigate the effect of compound buckling (Duan et al., 2002). For the purpose of evaluating an existing structure, the buckling mode interaction factor,  $\beta$ , proposed by Duan et al. (2002) is recommended to consider compound buckling effects.

## CHAPTER 5

### DUCTILE EARTHQUAKE RESISTING SYSTEMS

This chapter addresses design requirements for ductile earthquake resisting systems including steel Moment Frames (*MF*), steel braced frames such as Concentrically Braced Frames (*CBF*) and Eccentrically Braced Frames (*EBF*), and Buckling-Restrained Braced Systems (*BRBS*).

Ductile concrete substructures used in conjunction with steel superstructures shall be designed in accordance with the appropriate provisions specified in the *SDC*.

#### 5.1 MOMENT FRAMES

##### 5.1.1 General

For single level bents, inelastic deformations of *MF* under *DSH* shall be limited to columns only. All other components shall be designed to remain essentially elastic.

For multitier frame bents, capacity design principles, as well as the requirements of Articles 5.1.2 to 5.1.5 may be modified by the Designer to achieve column plastic hinging only at the top of the columns. Column plastic hinging at the base where fixity to the foundation is needed shall be assessed where applicable.

##### 5.1.2 Force Demands

Force demands on beams shall be determined by an analysis in which the forces at the ends of columns correspond to overstrength moments of columns.

Force demands on connections shall be determined by an analysis in which the forces at the ends of columns correspond to overstrength moments of columns, and the forces at the ends of beams correspond to the design strengths of the connected beams.

### 5.1.3 Moment Ratio

The beam and column strengths at the connection shall satisfy the following requirement:

$$\sum M_{ne}^* \geq \sum M_{oc}^* \quad (5.1.3-1)$$

where

$\sum M_{ne}^*$  = sum of the expected nominal flexural strength of the beam(s) at the intersection of the beam and the column centerlines (kip-in.).  $M_{ne}^*$  is shown in Figure C5.1.3-1

$\sum M_{oc}^*$  = sum of the overstrength flexural moments in the column(s) above and below the joint at the intersection of the beam and column centerlines (kip-in.).  $M_{oc}^* = M_{oc} + M_v$  as shown in Figure C5.1.3-1

$M_{oc}$  = overstrength moment of a ductile column =  $\Omega M_{ip}$  (kip-in.)

$M_{ip}$  = idealized plastic moment capacity of the column based on its expected material properties and the strain hardening at the significant damage level. It can be obtained by either a moment-curvature analysis or approximately equal to  $1.17M_{pe}$  (kip-in.)

$M_{pe}$  = expected plastic moment capacity of the column determined by the yield surface equations in Appendix C based on the expected yield strength  $F_{ye}$ , or approximated as  $Z_c(F_{ye} - P_u/A_g)$  (kip-in.)

$M_{ne}$  = expected nominal flexural strength of the beam (kip-in.)

$M_v$  = additional moment due to the shear amplification from the actual location of the column plastic hinge to the beam centerline (Figure C5.1.3-1) (kip-in.)

$A_g$  = gross cross-sectional area of a column (in.<sup>2</sup>)

$P_u$  = axial force due to seismic and permanent loads (kip)

$Z_c$  = plastic section modulus of a column (in.<sup>3</sup>)

### C5.1.3

For a ductile moment frame, the capacity design concept is applied to ensure that inelastic deformations only occur in the specially detailed ductile substructure elements. To ensure a weak-column strong-girder design, the beam-to-column strength ratio must satisfy this requirement.

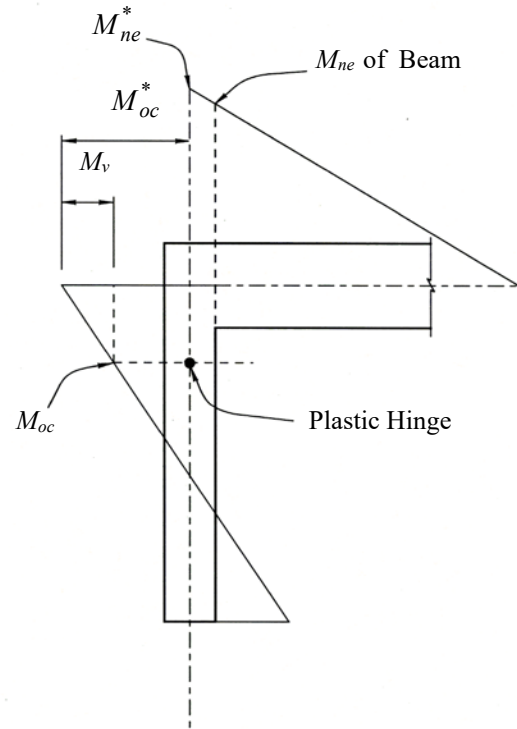

**Figure C5.1.3-1 Beam-to-Column Strength**

The 1.17 factor in the idealized plastic moment capacity accounts for the strain hardening at the significant damage level as specified in Article 2.5. It is very close to 1.15, the strain hardening factor due to flexure provided by the *AISC Prequalified Connections for Special and Intermediate Steel Moment Frames for Seismic Applications* for either A709 Grade 50 or A992 steel (AISC, 2014a).

## 5.1.4 Columns

### 5.1.4.1 General

Columns shall satisfy requirements of ductile members as specified in Articles 4.2 and 4.3.

Axial compression force in columns due to the seismic load combined with permanent loads shall not exceed  $0.3A_gF_y$ .

### 5.1.4.2 Plastic Regions

In the absence of test results, plastic regions for a column shall be taken as the larger of the following:

- Theoretical plastic hinge length,  $L_p$
- The maximum 1/8 of the clear height of a steel column, or
- 1.5 times the gross cross-sectional dimension in the direction of bending

Theoretical plastic hinge length of a beam-column shall be taken as:

$$L_p = L_o \left( 1 - \frac{1}{1.2 f_{bc}} \right) \quad (5.1.4.2-1)$$

where

$L_p$  = theoretical plastic hinge length (in.)

$L_o$  = distance between the point of maximum moment and the point of contra-flexure (in.)

$f_{bc}$  = shape factor, ratio of plastic moment to yield moment of a steel section subject to combined axial force and flexure

$$f_{bc} = f_b \left[ \frac{1 - \left( \frac{P_u}{P_{ye}} \right)^\beta}{1 - \frac{P_u}{P_{ye}}} \right] \quad (5.1.4.2-2)$$

$f_b$  = shape factor, ratio of plastic moment to yield moment of a steel section subject to pure flexure, as given in Table 5.1.4.2-1

### C5.1.4.1

The axial load limitation is enforced to ensure ductile column performance and to avoid early yielding and sudden strength and stiffness degradation when the columns are subjected to high axial loads.

### C5.1.4.2

The second and third bullets are plastic hinge lengths specified in the *AASHTO Seismic Guide Specifications* (AASHTO, 2011).

A factor of 1.2 in Eq. (5.1.4.2-1) is used to consider the strain hardening in plastic hinges.

**Table 5.1.4.2-1  $f_b$  Factor for Typical Steel Sections**

Section Shape	$f_b$
I-shaped strong axis	1.15
I-shaped weak axis	1.55
Rectangular HSS strong axis	1.27
Rectangular HSS weak axis	1.16
Square HSS	1.19
Round HSS	1.33
Built-up box	1.25
Welded steel pipe	1.27

Shape factor,  $f_b$  for I-shaped and HSS listed in Table 5.1.4.2-1 are the average values based on the *AISC Construction Manual Shapes Database* (AISC, 2014b); The  $f_b = 1.27$  for welded steel pipe is a theoretical value derived by Han and Chen (1985).

- $P_u$  = axial force due to seismic and permanent loads (kip)
- $P_{ye}$  = expected axial yield strength of a steel section =  $A_g F_{ye}$  (kip)
- $\beta$  = moment-axial force interaction parameter about the principal axis depending on cross section shapes and area distribution

Parameter  $\beta$  was developed by Duan and Chen (1990). Appendix C presents the yield surface equations for typical steel sections.

$$\beta = \begin{cases} 2.0 - 0.5\bar{B} \geq 1.3 & \text{for box and HSS} \\ 1.3 & \text{for I-shaped strong axis} \\ 2.0 + 1.2(A_w / A_f) & \text{for I-shaped weak axis} \\ 1.75 & \text{for round HSS} \end{cases} \quad (5.1.4.2-3)$$

- $\bar{B}$  = ratio of width to depth of box section with respect to bending axis
- $A_f$  = flange area of I-shaped section (in.<sup>2</sup>)
- $A_w$  = web area of I-shaped section (in.<sup>2</sup>)

**5.1.4.3 Expected Nominal Shear Strength**

The expected nominal shear strength of a column shall be determined in accordance with Articles 6.10.9 of the *AASHTO BDS*, except that  $F_{ye}$  is used in lieu of  $F_y$ .

When  $P_u/P_{ye} > 0.15$ , the expected nominal shear strength shall be multiplied by a reduction factor,  $\sqrt{1 - (P_u / P_{ye})^2}$ , where  $P_u$  is the axial force due to seismic and permanent loads (kip); and  $P_{ye}$  is the expected nominal axial yield strength of a gross section (kip).



### 5.1.5 Beams

Beams shall satisfy requirements of capacity-protected members as specified in Articles 4.2 and 4.3.

The expected nominal flexural strength of beams shall be determined in accordance with Articles 6.10 or 6.11 of the *AASHTO BDS* and the *Amendments*, except that  $F_{ye}$  is used in lieu of  $F_y$ .

### 5.1.6 Beam-to-Column Connections

The beam-to-column connections shall satisfy stability bracing requirements in accordance with Article 4.7

The beam-to-column connection and panel zone shall be designed in accordance with Article 7.2.



## 5.2 CONCENTRICALLY BRACED FRAMES

### 5.2.1 General

Inelastic deformations of *CBF* under *DSH* shall be limited to bracing members only. All other components shall be designed to remain essentially elastic. K-braced frames and tension-only frames shall not be used in *CBF*.

### 5.2.2 Force Demands

#### 5.2.2.1 Columns and Beams

Force demands on columns and beams shall be taken as the larger of the forces determined from the following two analyses:

- An analysis in which all braces are assumed to resist their overstrength forces in compression or in tension.
- An analysis in which all tension braces are assumed to resist their overstrength tensile forces and all compression braces to resist their overstrength post-buckling forces.

#### 5.2.2.2 Beam-to-Column Connections

When a brace or gusset plate connects to both members at a beam-to-column connection, force demands on the connection shall be determined by one of the following analyses:

### C5.2.1

*CBF* exhibit the best seismic performance and contribute significantly to the total hysteretic energy dissipation when the diagonal members undergo both yielding in tension and inelastic buckling in compression. The energy absorption capability of a brace in compression depends on its slenderness ratio ( $KL/r$ ) and its resistance to local buckling. Since *CBF* are subjected to more stringent detailing requirements, they are expected to withstand significant inelastic deformations under the *DSH*.

K-bracing is generally not considered desirable in concentrically braced frames and is prohibited because it has a very poor post-elastic performance. After the braces buckle, the action of the brace in tension induces large unbalanced lateral forces which may contribute to column failures.

Seismic provisions for *CBF* with tension-only braces have not been developed for use. Thus tension-only braced frames are not allowed for *CBF*.

- A simple connection: shear produced by the overstrength force of the brace and the expected nominal flexural strength of the beam.
- A moment connection: a moment corresponding to the smaller of the expected beam flexural strength and the sum of the expected nominal column flexural strengths ( $\sum F_{ye}Z$ ) in combination with force demands produced by the overstrength force of the brace.

### 5.2.2.3 Brace Connections

Force demands on brace connections shall be taken as the overstrength force of the brace in compression, tension and flexure, respectively. These forces are permitted to be considered independently without interaction.

### 5.2.3 Lateral Force Distribution

Braces shall be designed in alternate directions such that, for either direction of force parallel to the braces, at least 30% but no more than 70% of the total horizontal force along the line of brace is resisted in tension.

### 5.2.4 V-type and Inverted V-type Braces

Beams that are intersected by braces away from beam-to-column connections shall satisfy the following requirements:

- Beams shall be continuous between columns and designed to support the effects of all the prescribed tributary gravity loads and seismic demands assuming that the bracing is not present.
- Seismic force demands shall be taken as an unbalanced vertical force determined by using the overstrength force of the brace in tension and the overstrength post-buckling force of the brace as specified in Article 5.2.5.2.

### C5.2.3

Since the buckling and post-buckling strength of a brace in compression can be substantially less than one in tension, this requirement is included to balance the tensile and compressive resistance of a *CBF* and to help prevent accumulation of inelastic lateral displacement in one direction (AISC, 2010a).

### C5.2.4

These requirements (AISC, 2010a) ensure that the beam will not fail due to the large unbalanced force after buckling and yielding of the braces. The term “beams”, as used herein refers to the horizontal members of a *CBF*.

## SPECIFICATIONS

## COMMENTARY

- Beams shall be braced to satisfy the requirements for capacity-protected members specified in Table 4.3-1. The top and bottom flanges of the beam at the point of intersection of the braces shall be adequately braced laterally. The lateral bracing shall be designed for 2% of the expected nominal beam flange strength ( $F_{ye}b_f t_f$ ) unless the beam has sufficient out-of-plane strength and stiffness.

### 5.2.5 Diagonal Braces

#### 5.2.5.1 General

Braces shall satisfy requirements of ductile diagonal braces as specified in Articles 4.2 and 4.3. The brace effective net area shall not be less than the brace gross area. When reinforcing plates are used on braces, the following requirements shall be satisfied:

- The specified minimum yield strength of the reinforcing plates shall not be less than the specified minimum yield strength of the brace.
- The connections of the reinforcing plates to the brace shall be designed for the force corresponding to the expected nominal strength of the reinforcing plate on each side of a reduced area.

#### 5.2.5.2 Overstrength Force

The overstrength force of a brace shall be taken as its idealized plastic strength multiplied by an overstrength factor,  $\Omega$  as specified in Article 2.6.3.

#### 5.2.5.3 Idealized Plastic Strength

The idealized plastic strength of a brace shall be taken as its expected nominal strengths multiplied by a factor 1.17.

#### 5.2.5.4 Expected Nominal Strength

The expected nominal strength of a brace in compression shall be determined in accordance with Article 6.9.4 of the *AASHTO BDS*, except that  $F_{ye}$  is used in lieu of  $F_y$ .

One method of demonstrating sufficient out-of-plane strength and stiffness of the beam is to apply a bracing force of  $0.02(F_{ye}b_f t_f)$  to each flange so as to form a torsional couple in conjunction with the flexural forces induced by seismic and permanent loads. The stiffness of the beam with respect to this torsional loading should be larger than  $20(F_{ye}b_f t_f / L_b)$ , where  $b_f$  and  $t_f$  are the flange width and thickness of a beam, respectively; and  $L_b$  is the unbraced length of the beam.

#### C5.2.5.1

It should be noted that some, if not all, steel materials commonly used for braces have expected yield strengths significantly higher than their specified minimum yield strengths; some have expected yield strengths almost as high as their expected tensile strength. The purpose of the brace effective net area requirement is to prevent net section rupture prior to significant ductility; having no reduction in the section is deemed sufficient to ensure this ductile behavior (AISC, 2010a). This requirement is not applicable to connection element since the tensile strength of a connection element for ductile members is governed by yielding in the gross section, and that fracture in the net section and block shear rupture are prevented in accordance with Article 7.5.3.

#### C5.2.5.3

The 1.17 factor in the idealized plastic brace strengths accounts for the strain hardening at the significant damage level as specified in Article 2.5.

The expected nominal post-buckling strength of a brace shall be taken as 0.3 times the expected nominal brace strength in compression.

The expected nominal strength of a brace in tension shall be taken as  $F_{ye}A_g$ .

**5.2.5.5 Built-up Braces**

For built-up bracing members, the slenderness ratio of individual elements between the connectors shall not be greater than 0.4 times the governing slenderness ratio of the built-up members as a whole. The sum of design shear strengths of connectors between individual elements shall not be less than the expected nominal tensile strength of each element. The spacing of connectors shall be uniform. At least two connectors shall be used. Connectors shall not be located within the middle one-fourth of the clear brace length. When buckling of braces about their critical buckling axis does not cause shear in the connectors, the spacing of the connectors shall be such that the slenderness ratio of the individual elements between the connectors does not exceed three-fourths times the governing slenderness ratio of the built-up member.

**5.2.5.6 Plastic Regions**

Plastic regions for a brace shall be the center one-quarter of the brace length and a zone adjacent to each connection equal to the brace depth in the plane of buckling.

**C5.2.5.6**

Figures C5.2.5.6-1 and C5.2.5.6-2 show plastic regions (shaded zones) of an inverted V-braced frame and an X-braced frame. Tests (Tang and Goel, 1989; Goel and Lee, 1992) have shown that a plastic hinge is anticipated at any of the brace quarter points for inverted V-braced frames and X-braced frames.

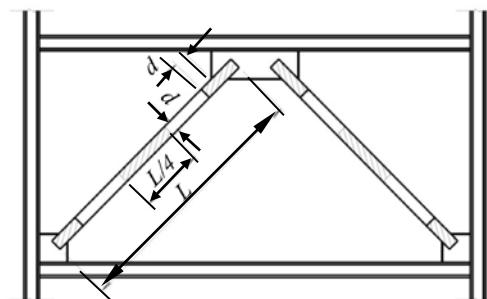

**Figure C5.2.5.6-1 Plastic Regions of Inverted Braced Frame**

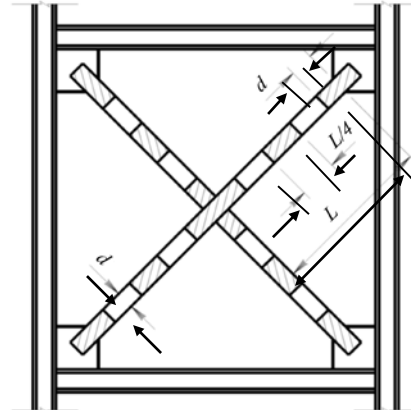

Figure C5.2.5.6-2 Plastic Regions of X-Braced Frame

### 5.2.6 Columns

Columns shall satisfy requirements of capacity-protected members as specified in Articles 4.2 and 4.3.

The expected nominal strength of a column shall be determined in accordance with Article 6.9.4 of the *AASHTO BDS*, except that  $F_{ye}$  is used in lieu of  $F_y$ .

### 5.2.7 Beams

Beams shall satisfy requirements of capacity-protected members as specified in Articles 4.2 and 4.3.

The expected nominal flexural strength of a beam shall be determined in accordance with Articles 6.10 or 6.11 of the *AASHTO BDS* and the *Amendments*, except that  $F_{ye}$  is used in lieu of  $F_y$ .

### 5.2.8 Connections

#### 5.2.8.1 Beam-to-Column Connections

The expected nominal strength of a beam-to-column connections shall be determined in accordance with Article 7.2.

#### 5.2.8.2 Brace Connections

The expected nominal strength of a brace connections shall be determined in accordance with Article 7.3.

### 5.3 ECCENTRICALLY BRACED FRAMES

#### 5.3.1 General

Inelastic deformations of *EBF* under *DSH* shall be limited to the links between two braces. All other components shall be designed to remain essentially elastic.

#### 5.3.2 Force Demands

Force demands on diagonal braces and their connections, beams outside of links and columns shall be determined by an analysis in which the forces at the ends of links correspond to the overstrength shear force of the link. The overstrength shear force of a link shall be taken as its idealized plastic shear strength multiplied by an overstrength factor,  $\Omega$ , as specified in Article 2.6.3.

#### C5.3.1

Research results have shown that a well-designed *EBF* system possesses high stiffness in the elastic range and excellent ductility capacity in the inelastic range for building structures (Popov et al., 1989). High elastic stiffness is provided by the braces. High ductility capacity is achieved by transmitting one brace force to another brace or columns through shear and flexural yielding in a short beam segment designated as a “link”. When properly detailed, these links provide a reliable source of energy dissipation. By following the capacity design concept, buckling of braces and beams outside of the link can be prevented because these members have been designed to remain essentially elastic while resisting forces associated with the fully yielded and strain hardened links. The shear links have been used in the tower of the new San Francisco-Oakland Bay Bridge Self-anchored Suspension Span (Nader and Maroney, 2007) and in the seismic retrofit of the Richmond-San Rafael Bridge (Vincent, 1996). The provisions in this Article are based on the *AISC Seismic Provisions* (AISC, 2010a) and Caltrans sponsored shear links experimental testing (McDaniel et al., 2002 and 2003; Dusicka et al., 2002 and 2010; Berman and Bruneau, 2007, 2008a, 2008b, 2013; Bruneau, 2013).

### 5.3.3 Link Rotation Angle

The link rotation angle, i.e., the inelastic angle between the link and the beam outside of the link, shall not exceed the following values (Figure C5.3.3-1):

$$0.02 \text{ rad} \leq \gamma_p = 0.02 + 0.06 \left( 2.6 - \frac{e}{\frac{M_p}{V_p}} \right) \leq 0.08 \text{ rad} \quad (5.3.3-1)$$

- $e$  = shear link length, the clear distance between the ends of two diagonal braces or between the diagonal braces and the column face (in.)
- $M_p$  = nominal plastic flexural strength (kip-in.) =  $F_y Z$
- $Z$  = plastic section modulus of a link in the plane of bending (in.<sup>3</sup>)
- $V_p$  = nominal shear yield strength (kip) =  $0.58 F_y D t_w$
- $D$  = web depth, clear distance between flanges (in.)
- $t_w$  = web thickness (in.)

### C5.3.3

Links yielding in shear possess a greater rotational capacity than links yielding in bending as shown in Figure C5.3.3-1.

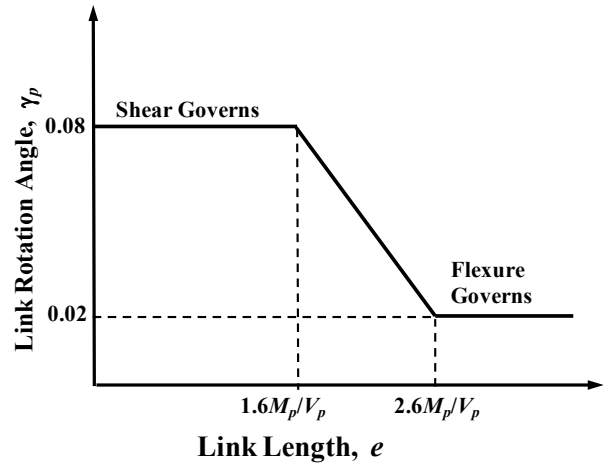

**Figure C5.3.3-1 Link Length vs. Link Rotation Angle**

The link rotation angle,  $\gamma_p$ , is the plastic rotation angle between the link and the beam outside of the link and can be conservatively determined assuming that the braced bay deforms in a rigid-plastic mechanism. The plastic mechanism for one *EBF* configurations is illustrated in Figure C5.3.3-2.

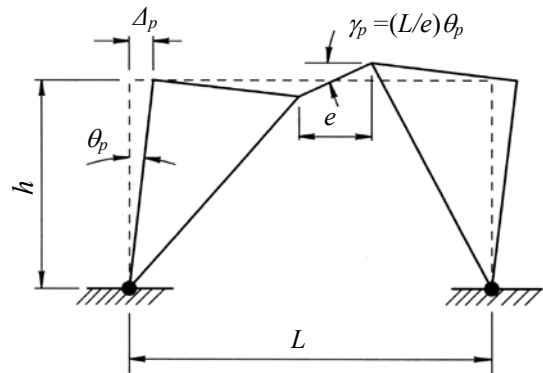

**Figure C5.3.3-2 Plastic Mechanisms of *EBF***

The plastic rotation is determined using a frame drift angle,  $\theta_p = \Delta_p/h$ , where  $\Delta_p$  is the plastic frame displacement and  $h$  is the frame height. Alternatively, the plastic rotation angle can be determined more accurately by inelastic nonlinear analyses (Tao and Treyger, 2014).

### 5.3.4 Links

#### 5.3.4.1 General

The links shall satisfy the following requirements:

- Links shall be I-shaped cross sections (rolled wide-flange or built-up sections) or built-up box sections. HSS shall not be used.
- Links shall satisfy the requirements of Table 4.2-2. For box-shaped links with  $e \leq 1.6M_p/V_p$ , width-to-thickness ratios of the webs shall not exceed  $1.67\sqrt{E/F_y}$ .
- The web of a link shall be single thickness. Doubler-plate reinforcement and web penetrations shall not be used.
- For links made of built-up sections, complete-joint-penetration groove welds shall be used to connect the webs to the flanges.
- Bracings shall be provided at both the top and bottom link flanges at the ends of the link. Bracing shall be designed for expected plastic hinge locations in accordance with Article 4.6.

#### 5.3.4.2 Idealized Plastic Shear Strength

The idealized plastic shear strength of a link shall be taken as its expected nominal shear strength,  $V_{pe}$ , multiplied by a factor 1.17.

#### 5.3.4.3 Expected Nominal Shear Strength

The expected nominal shear strength of a link,  $V_{pe}$ , shall be taken as the smaller value obtained in accordance with the shear yielding in the web and the flexural yielding in the gross section:

- For shear yielding:

$$V_{pe} = \begin{cases} 0.58F_{ye}Dt_w & \text{for } \frac{P_u}{P_{ye}} \leq 0.15 \\ 0.58F_{ye}Dt_w \sqrt{1 - \left(\frac{P_u}{P_{ye}}\right)^2} & \text{for } \frac{P_u}{P_{ye}} > 0.15 \end{cases} \quad (5.3.4.3-1)$$

where

#### C5.3.4.1

As indicated in Bruneau et al. (2011), HSS sections cannot be used for links, due to concerns about their low cycle fatigue life under large inelastic deformations.

#### C5.3.4.2

The 1.17 factor in the idealized plastic shear strength accounts for the strain hardening at the significant damage level specified in Article 2.5.



$P_u$  = axial force due to seismic and permanent loads (kip)

$P_{ye}$  = expected nominal axial yield strength of a gross section =  $A_g F_{ye}$  (kip)

- For flexural yielding:

$$V_{pe} = \frac{2M_{pe}}{e} \quad (5.3.4.3-2)$$

where

$$M_{pe} = \begin{cases} F_{ye} Z & \text{for } \frac{P_u}{P_{ye}} \leq 0.15 \\ F_{ye} Z \left( \frac{1 - P_u / P_{ye}}{0.85} \right) & \text{for } \frac{P_u}{P_{ye}} > 0.15 \end{cases} \quad (5.3.4.3-3)$$

#### 5.3.4.4 Link Length

When  $P_u/P_y < 0.15$ , the length of the link shall have no upper limit.

When  $P_u/P_y > 0.15$ , the length of the links shall satisfy the following:

$$e \leq \begin{cases} \frac{1.6M_p}{V_p} & \text{for } \rho' \leq 0.5 \\ \frac{1.6M_p}{V_p} (1.15 - 0.3\rho') & \text{for } \rho' > 0.5 \end{cases} \quad (5.3.4.4-1)$$

$$\rho' = \frac{P_u / P_y}{V_u / V_p} \quad (5.3.4.4-2)$$

where

$V_u$  = shear force due to seismic and permanent loads (kip)

#### 5.3.4.5 Link Stiffeners for I-Shaped Sections

Full depth transverse stiffeners shall be provided on both sides of the link web at the diagonal brace ends of the link and at intermediate locations. Intermediate stiffener spacing,  $d_o$ , shall satisfy the following requirements:

- When  $e \leq 1.6M_p/V_p$

$$d_o \leq 22t_w \left( \frac{0.08 - \theta_p}{0.06} \right) + 30t_w - \frac{d}{5} \quad (5.3.4.5-1)$$

#### C5.3.4.4

There is no upper limit on link length for low axial force. The limitations on link rotation angle in Article 5.3.3 provide a practical lower limit on the link length (AISC, 2010a).

#### C5.3.4.5

where

$d$  = full depth of a link web (in.)

- When  $2.6M_p/V_p \leq e < 5M_p/V_p$ , from each end of link,

$$d_o \leq 1.5b_f \quad (5.3.4.5-2)$$

- When  $1.6M_p/V_p < e < 2.6M_p/V_p$ , stiffener spacing shall satisfy both Equations (5.3.4.5-1) and (5.3.4.5-2).
- When  $e > 5M_p/V_p$ , intermediate web stiffeners are not required.

Link stiffeners shall have a combined width not less than  $(b_f - 2t_w)$  and a thickness not less than the larger of  $0.75t_w$  or 3/8 in., where  $b_f$  and  $t_w$  are the link width and link web thickness, respectively.

Fillet welds connecting a stiffener to the link web shall be designed for a force of  $F_{yst}A_{st}$ , where  $F_{yst}$  is the specified minimum yield strength of the stiffener and  $A_{st}$  is the horizontal cross-sectional area of the stiffener, and shall be terminated at a minimum distance of  $3t_w$  from the toe of the web-to-flange weld.

Fillet welds connecting a stiffener to the link flanges shall be designed for a force of  $F_{yst}A_{st}/4$ .

The termination distance of fillet welds is set to improve the link deformation capacity (McDaniel et al., 2002).

### 5.3.4.6 Link Stiffeners for Box Sections

Full depth transverse stiffeners shall be provided on one side of each link web at the diagonal brace connections and intermediate locations. These stiffeners shall be welded to the outside or inside face of the link webs. Stiffeners are not required to be welded to link flanges. These stiffeners shall each have a width not less than  $b/2$ , where  $b$  is the inside width of the box. These stiffeners shall each have a thickness not less than the larger of  $0.75t_w$  or 1/2 in., where  $t_w$  is the web thickness.

Intermediate stiffener spacing,  $d_o$ , shall satisfy the following requirements:

- When  $e \leq 1.6M_p/V_p$  and  $\frac{h}{t_w} \geq 0.64 \sqrt{\frac{E}{F_y}}$

$$d_o \leq 20t_w - \frac{d - 2t_f}{8} \quad (5.3.4.6-1)$$

- When  $e \leq 1.6M_p/V_p$  and  $\frac{h}{t_w} < 0.64 \sqrt{\frac{E}{F_y}}$   
No intermediate stiffeners are required.
- When  $e > 1.6M_p/V_p$   
No intermediate stiffeners are required.

Fillet welds connecting a stiffener to the link web shall be designed for a force of  $F_{yst}A_{st}$ , where  $F_{yst}$  is the specified minimum yield strength of the stiffener and  $A_{st}$  is the horizontal cross-sectional area of the stiffener.

#### 5.3.4.7 Plastic Regions

The plastic regions shall be the lengths of links.

#### 5.3.5 Diagonal Braces

Diagonal braces shall satisfy requirements of capacity-protected members as specified in Articles 4.2 and 4.3.

The expected nominal brace strength in compression shall be determined in accordance with Article 6.9.4 of the *AASHTO BDS*, except that  $F_{ye}$  is used in lieu of  $F_y$ .

The expected nominal brace strength in tension shall be determined in accordance with Article 6.8.2 of the *AASHTO BDS*, except that  $F_{ye}$  and  $F_{ue}$  are used in lieu of  $F_y$  and  $F_u$ , respectively.

#### 5.3.6 Columns

Columns shall satisfy requirements of capacity-protected members as specified in Articles 4.2 and 4.3.

The expected nominal strength of columns shall be determined in accordance with Article 6.9.4 of the *AASHTO BDS*, except that  $F_{ye}$  is used in lieu of  $F_y$ .

### 5.3.7 Beams

Beams shall satisfy requirements of capacity-protected members as specified in Articles 4.2 and 4.3.

The expected nominal strength of a beam outside the link shall be determined in accordance with Articles 6.10 or 6.11 of the *AASHTO BDS* and the *Amendments*, except that  $F_{ye}$  is used in lieu of  $F_y$ .

### 5.3.8 Connections

#### 5.3.8.1 *Beam-to-Column Connections*

The expected nominal strength of a beam-to-column connection shall be determined in accordance with Article 7.2.

#### 5.3.8.2 *Brace Connections*

Connections of braces designed to resist a portion of the link end moment shall be designed as fully restrained moment connections.

The expected nominal strength of a brace connection shall be determined in accordance with Article 7.3.

## 5.4 BUCKLING-RESTRAINED BRACED SYSTEMS

### 5.4.1 General

Inelastic deformation of buckling-restrained braced systems (*BRBS*) under seismic loads shall be limited to buckling-restrained braces (*BRB*) only. All other components shall be designed to remain essentially elastic. K-type braced frames shall not be used in buckling restrained braced systems. *BRB* shall not be considered as resisting gravity loads.

### 5.4.2 Force Demands

Force demands on brace connections and adjoining members shall be determined by an overstrength factor,  $\Omega$ , specified in Article 2.6.3, times the forces determined from an analysis in which all *BRBs* are assumed to reach their adjusted brace strengths given by Articles 5.4.3.2.

### C5.4.1

*BRBS* are expected to provide significant inelastic deformation capacity through brace yielding in tension and compression. Due to their excellent energy dissipation capacity, *BRBS* have been widely used in concentrically braced frames in building structures after the 1994 Northridge and the 1995 Kobe Earthquakes (Uang et al., 2004). *BRB* are considered to be highly ductile members by the *AISC Seismic Provisions* (AISC, 2010a). There is an increasing trend for using *BRBS* in bridge structures (Usami et al., 2005 and 2009; Carden et al., 2006a; Wei and Bruneau, 2013; Lanning et al., 2014; Uang et al., 2014). Large *BRBS* were used for the first time in the U.S. to improve the performance of the Foresthill Bridge, California (Reno and Pohll, 2013). Seismic performance of straight steel girder bridges using *BRBS* was investigated by Carden et al. (2006), and Lanning et al. (2011) studied the feasibility of using *BRBS* for long span bridges. The use of bi-directional *BRB* for implementation in straight and skewed bridge superstructures was investigated by Wei and Bruneau (2015). The provisions in this Article are based on *BRB* experimental testing (Lanning et al., 2011 and 2013), the proposed *BRB* guidelines (Lanning and Uang, 2014), and the *AISC Seismic Provisions* (AISC, 2010a).

### 5.4.3 Braces

#### 5.4.3.1 Assembly

The brace shall consist of a structural steel core and a system that restrains the steel core from buckling.

Plates used in the steel core that are 2 inches or greater in thickness shall satisfy Charpy V-notch testing requirements specified in Article 2.4. Splices in the steel core shall not be used.

Buckling-restraining systems shall consist of the casing for the steel core in one of the following configurations:

- Conventional *BRB* – the steel core is inside a mortar filled steel restraining tube.
- All-steel *BRB* – the steel core is inside built-up steel restraining members.
- Others based on test results in conformance with Article 5.4.4.

In stability calculations, beams, columns and gussets connecting the core shall be considered parts of this system. The buckling-restraining systems shall prevent local and overall buckling of the steel core prior to the expected deformation. The steel core shall be designed to resist the entire axial force in the brace.

#### 5.4.3.2 Adjusted Brace Strength

(1) The adjusted brace strength in tension,  $T_a$ , shall be taken as:

$$T_a = \omega_T F_{yesc} A_{sc} \quad (5.4.3.2-1)$$

where

$A_{sc}$  = cross-sectional area of the yielding segment of the steel core (in.<sup>2</sup>)

$F_{yesc}$  = expected yield strength of the steel core which is equal to  $R_y F_y$  or the measured yield strength of the steel core determined from a coupon test (ksi)

$\omega_T$  = strain hardening adjustment factor for tension

#### C5.4.3.1

Figure C5.4.3.1 shows typical *BRB* details.

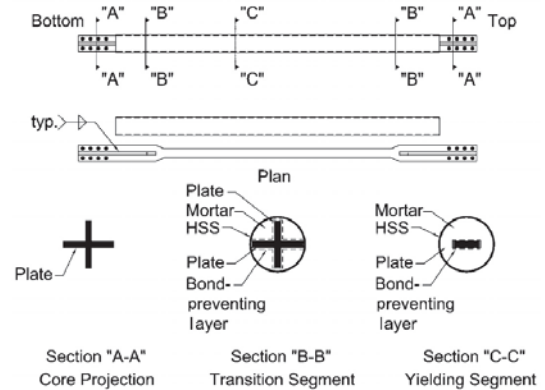

**Figure C5.4.3.1-1 Typical *BRB* details  
(Courtesy of R. Tremblay)**

Extensive tests and studies on conventional *BRB* and limited tests on all-steel *BRB* have been made and are available in the literature (Uang et al., 2004).

#### C5.4.3.2

Using two strain hardening adjustment factors, one for tension and one for compression, as shown in Figure C5.4.3.2-1, represents a deviation of the design procedure in the *AISC Seismic Provisions* (AISC, 2010a) and was recommended by Lanning et al. (2013).

It should be noted that Figure C5.4.3.2-1 is intended to display the relative values of the adjusted brace forces,  $T_a$  and  $P_a$ , to the expected yield strength,  $T_{ye}$  and  $P_{ye}$ . The curve shown represents the “backbone” curve of a *BRB* response given an arbitrary set of equal tension and compression values of  $\Delta_{bm}$ .

SPECIFICATIONS

COMMENTARY

- (2) The adjusted brace strength in compression,  $P_a$ , shall be taken as:

$$P_a = \omega_c F_{yesc} A_{sc} \quad (5.4.3.2-2)$$

where

$\omega_c$  = strain hardening adjustment factor for compression

- (3) The strain hardening adjustment factors,  $\omega_T$  and  $\omega_C$ , are ratios of the maximum tension and compression forces measured from the qualification tests specified in Article 5.4.4 to the measured yield forces of the test specimens, respectively.
- (4) When tests are not conducted dynamically, the adjusted brace strengths obtained from the testing shall be amplified by 1.2 for locations within 9.4 miles of a major fault line. For locations 15.6 miles away or greater, the amplifying factor may be taken as 1.0. Locations between 9.4 and 15.6 miles shall use a factor determined by linear interpolation.

5.4.3.3 Plastic Regions

The plastic regions shall include only the yielding core of the brace.

5.4.4 Qualification Tests

5.4.4.1 General

The requirements in this Article shall be specified in the project special provisions.

Except as specified in this Article, the design of braces shall be based on the results from qualification tests in accordance with the procedures and acceptance criteria of Section K3 of the *AISC Seismic Provisions* (AISC, 2010a). Qualification test results shall consist of at least two successful cyclic tests: two nominally identical braces subjected to tests of equal magnitudes but opposite loading directions, consisting of uniaxial or combined axial and subassembly deformations including brace connection end rotations. If subassembly deformations are not incorporated, results from an additional such test shall be recorded. The tests shall satisfy the following:

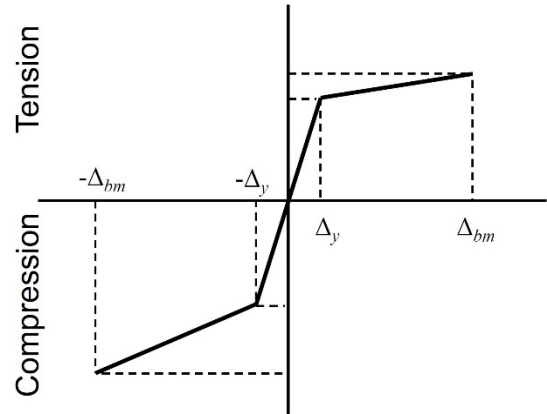

Figure C5.4.3.2-1 Adjusted Brace Strengths

The near-fault is defined as a site which is within a distance of 15.6 miles from a major fault line as specified in the *SDC Appendix B* (Caltrans, 2013). When testing does not include the strain rates specified in Table C5.4.4.3-1 amplification of the adjusted brace strength accounts for the strain-rate-induced increase in overstrength observed by Lanning et al. (2013).

C5.4.4.1

The qualification tests of the *Specifications* are developed based on Section K3 of the *AISC Seismic Provisions* (AISC, 2010a) and recommendations from Lanning and Uang (2014).

The purposes of the testing of individual braces is to provide evidence that a *BRB* satisfies the requirements for strength and inelastic deformation by the *Specifications* and to determine maximum *BRB* forces for design of adjoining elements. The purpose of testing the brace subassembly is to provide evidence that the *BRB* design, including end connections can sufficiently accommodate the deformation and rotational demands associated with the seismic effect on the structural framing. Furthermore, the subassembly test is intended to demonstrate that the hysteretic behavior of the brace

## SPECIFICATIONS

- Test specimens shall be tested by loading sequences in accordance with requirements in Articles 5.4.4.2 or 5.4.4.3. Additional increments of loading beyond that required are permitted, as is the addition of expected subassemblage deformations.
- Two nominally identical specimens shall be tested to equal and opposite loading sequences, as required in Articles 5.4.4.2 or 5.4.4.3 such that the adjusted brace strengths can be determined per Article 5.4.3.2, and that the maximum and minimum difference between concurrent compression and tension brace forces may be established in consideration of Article 5.4.5.
- Gusset connection details used for prototypes shall be simulated by test specimens.
- For *BRB* intended for implementation on bridges located at more than 15.6 miles away from a major fault line, the test specimens shall be subjected to the Loading Sequence 1 as specified in Article 5.4.4.2.
- For *BRB* intended for implementation on bridges located at 15.6 miles or less from a major fault line, the test specimens shall be subjected to the Loading Sequence 2 as specified in Article 5.4.4.3.

#### 5.4.4.2 Loading Sequence 1

The loading sequence 1 shall be taken as the loading protocol prescribed by Section K3 of the *AISC Seismic Provisions* (AISC, 2010a), with  $\Delta_{bm}$  equal to the design-level deformation applicable to the *BRB* bridge application under consideration. The *BRB* test specimens shall achieve a minimum cumulative inelastic axial deformation of 250 times the yield deformation which is defined as the deformation corresponding to the first significant yield of steel specimen.

## COMMENTARY

in the subassemblage is consistent with that of any individual *BRB* elements tested uniaxially (AISC, 2010a).

*BRB* and *BRB* subassemblages to be tested should include the intended gusset connection details for either prototype design and/or as-built plans. Gusset plate instabilities observed in several testing programs (Tsai et al., 2008; Lanning et al., 2013) have highlighted the importance of *BRB* gusset connection out-of-plane stiffness and/or buckling strength.

#### C5.4.4.2

Tests following the loading protocol specified in the *AISC Seismic Provisions* may be adequate for bridges expected to only be subjected to far-fault ground motions. However, it must be noted that the AISC protocol was developed through analysis of multistory building frames with *BRB*, subjected to a suite of design earthquakes (Sabelli et al., 2003). Before further research is conducted on the effects of far-fault ground motions on bridges equipped with *BRB*, the minimum required cumulative inelastic axial deformation of 200, as specified in the *AISC Seismic Provisions*, is conservatively increased to 250 for bridge applications. Available *BRB* testing shows that this requirement can be easily satisfied.





SPECIFICATIONS

COMMENTARY

**5.4.4.3 Loading Sequence 2**

The loading sequence 2 shall be taken as the loading protocol provided in Table C5.4.4.3-1 and Figure 5.4.4.3-1. If a *BRB* is tested dynamically, the strain rates accompanying the yielding core strains in Table C5.4.4.3-1 shall be achieved during testing.

**C5.4.4.3**

The *AISC Seismic Provisions* (AISC, 2010a) do not address the near-fault ground motion effects. The testing protocol in this section was specifically developed for long-span bridges under near fault ground motions and corresponds to a cumulative inelastic axial deformation of approximately 450 times the yield deformation. It more closely represents a *DSH* scenario, based on an analysis for the Vincent Thomas Bridge (Lanning et al., 2013). In that study, the design spectrum represented a 3.8% chance of exceedance in the remaining 125-year service life, as opposed to the typical AASHTO design basis earthquake having a 7% chance in 75 years.

**Table C5.4.4.3-1 Near-Fault Protocol Strains and Corresponding Dynamic Peak Strain Rates**

Step Number	Core Strain (%)	Strain Rate (in/in/sec)	Step Number	Core Strain (%)	Strain Rate (in/in/sec)
1	-0.2	-0.01	24	1.6	0.07
2	0.3	0.01	25	0.0	-0.07
3	-0.2	-0.03	26	1.4	0.07
4	0.3	0.02	27	0.1	-0.04
5	-0.6	-0.03	28	1.3	0.04
6	0.4	0.04	29	0.1	-0.04
7	-0.6	-0.09	30	1.2	0.04
8	0.9	0.10	31	0.2	-0.02
9	-1.0	-0.13	32	1.1	0.01
10	1.0	0.14	33	0.2	-0.01
11	-1.7	-0.18	34	1.1	0.01
12	5.0	0.30	35	0.3	-0.01
13	-3.5	-0.30	36	1.0	0.01
14	3.3	0.31	37	0.3	-0.01
15	-3.0	-0.21	38	1.0	0.01
16	2.4	0.17	39	0.4	-0.01
17	-0.5	-0.14	40	0.9	0.01
18	1.7	0.13	41	0.5	-0.01
19	-0.3	-0.11	42	0.9	0.01
20	1.7	0.11	43	0.5	-0.01
21	-0.3	-0.11	44	0.8	0.01
22	1.6	0.11	45	0.6	-0.01
23	-0.1	-0.07			

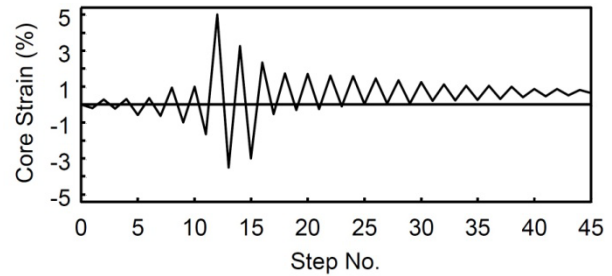

Figure C5.4.4.3-1 Near-Fault Loading Protocol

#### 5.4.4.4 Acceptance Criteria

At least two nominally identical *BRB*, per Article 5.4.4.1, shall sustain the loading specified in Articles 5.4.2.2 or 5.4.4.3. All tests shall satisfy the following requirements:

- The *BRB* shall exhibit stable, repeatable behavior with positive incremental stiffness.
- There shall be no rupture, instability, or *BRB* end connection failure.
- The *BRB* test specimens shall not exhibit signs of degradation in resisting force while providing steady consistent cyclic response.

#### 5.4.5 V-type and Inverted V-type Braces

Members that are intersected by *BRB* away from their connections shall satisfy the following requirements:

- Members shall be continuous between their connections and designed to support the effects of all the prescribed tributary gravity loads.
- Members shall be designed in consideration of two possible unbalanced *BRB* force scenarios, as determined from testing. Concurrent tension and compression forces in *BRB* shall be considered.
- The maximum and minimum differences between brace strengths in tension and in compression shall be measured at corresponding excursions during the testing required by Articles 5.4.4.2 or 5.4.4.3, as shown in Figure C5.4.5-2.
- Members shall be laterally braced in accordance with Article 5.2.5

#### C5.4.5

One of the primary considerations of the testing requirements for *BRB* specified in the *AISC Seismic Provisions* (AISC, 2010a) is the determination of the difference between compression and tension brace forces. The difference is quantified by the compression strength adjustment factor,  $\beta$ , which is defined as the ratio of the maximum compression and tension forces within *each cycle* applied to one test specimen. An example is shown in Figure C5.4.5-1(a), where corresponding forces  $T_{t1}$  and  $P_{t2}$  as measured at times  $t_1$  and  $t_2$  define the value of  $\beta$  as shown. In the *AISC* design procedure these unbalanced forces are assumed to act on the member intersected by *BRB* simultaneously, causing the resultant force direction to be away from the braces and of a magnitude proportional to  $\beta$ , as shown in Figure C5.4.5-1(b); per capacity design, the intersected member needs to be designed to resist this unbalance force. The combination of symmetric loading cycles and the use of subsequent peak *BRB* forces, in tension and *then* compression, cause

compression forces to almost exclusively be larger in magnitude than tension forces and  $\beta$  is always taken as greater than 1.0. The maximum value of  $\beta$  obtained from testing is then used for determination of the unbalanced forces as specified in the *AISC Seismic Provisions* (AISC, 2010a). Furthermore, the definition and calculation of  $\beta$  are not applicable to unsymmetrical cycles such as those experienced in near-fault loading cases, like those studied by Lanning et al. (2013).

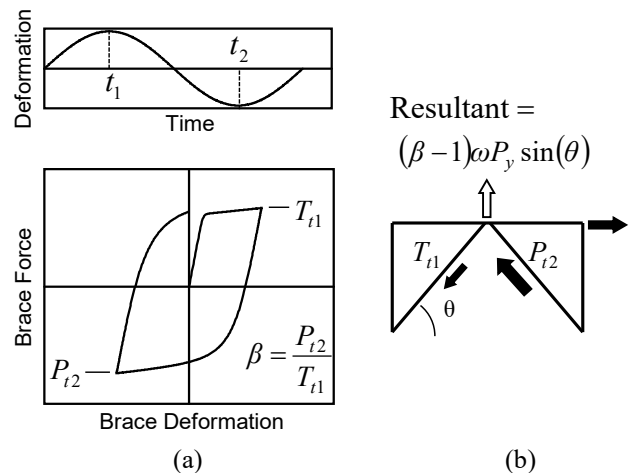
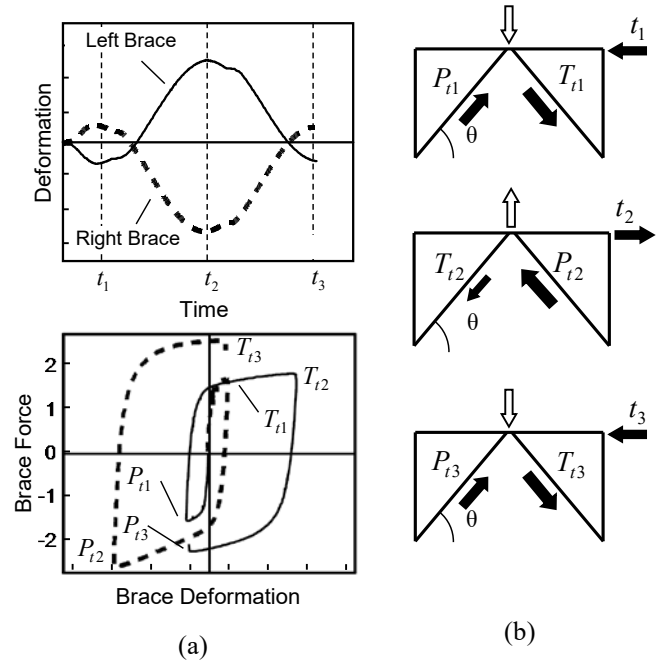

**Figure C5.4.5-1 Unbalanced BRB Loading as Defined by *AISC Seismic Provisions* (2010a)**

However, the possibility exists for tension forces to be greater than the corresponding compression forces for actual brace loadings with a *BRB* system, especially for near-fault ground excitations, i.e., loading sequence 2 in Article 5.4.4.3 (Lanning et al., 2013). A portion of testing results from two nominally identical braces subjected to equal but opposite loading protocols are shown in Figure C5.4.5-2(a), and the *Left Brace* and *Right Brace* are illustrated in Figure C5.4.5-2(b). Each brace peak deformation and normalized force response are listed in Table C5.4.5-1. It is clear that at *each excursion*,  $t_1$  through  $t_3$ , either tension or compression forces in the *BRBs* may be larger in magnitude than the other. The corresponding unbalanced loading conditions are shown in Figure C5.4.5-2(b).

At time  $t_1$  the *Right Brace* exhibits a larger tension force magnitude than the *Left Brace* compression force, thereby causing the resultant force

on the *BRB* intersected member to be directed toward the braces. Conversely, at time  $t_2$  the *Left Brace* exhibits a larger compression force than the *Right Brace* tension force, thereby causing the resultant force to be directed away from the braces. Time  $t_3$  again shows tension larger than compression. These excursions demonstrates two possible unbalanced loading cases, and each has a different magnitude of unbalanced force found from the difference between the two *BRB* forces.



**Figure C5.4.5-2 Two Possible Unbalanced Force Cases for *BRB* System**

**Table C5.4.5-1 Measured Unbalanced Forces from Equal and Opposite Tests (Lanning et al., 2013)**

Excursion No.	Peak Core Strain			Normalized Peak Forces	
	Time	Brace	(%)	$\omega_T$	$\omega_C$
1	$t_1$	Left	-1.0	-	1.15
		Right	1.0	1.28	-
2	$t_2$	Left	4.7	1.38	-
		Right	-4.7	-	1.92
3	$t_3$	Left	-0.9	-	1.68
		Right	0.9	1.95	-



SPECIFICATIONS

COMMENTARY

For *BRBS* with two adjoining braces, each brace undergoes simultaneous and (approximately) equal yet opposite deformations in a seismic event. Testing using two braces subjected to equal and opposite deformations is, therefore, more consistent with the actual *BRBS* deformations. The assumptions inherent in using measurements from a single *BRB*, as specified in the *AISC Seismic Provisions* (AISC, 2010a), are inconsistent with the deformation of *BRBS* with two adjoining braces. The requirements of testing two nominally identical braces to equal and opposite protocols, as prescribed in Article 5.4.4.1, allows the measurement of these concurrent forces at *each excursion* as described above. From the testing results, the maximum unbalanced force for each case can then be obtained and used in the capacity design of the member intersected by two adjoining *BRB*.

## CHAPTER 6

### SLAB-ON-STEEL GIRDER BRIDGES

This chapter addresses seismic design requirements for concrete slab-on-steel girder bridges.

#### 6.1 GENERAL

*Ordinary Standard* slab-on-steel girder bridges shall generally be designed to ensure that inelastic deformation occurs in the ductile substructure elements. As alternatives, inelastic deformations may be permitted in end cross frames or seismic isolation bearings to prevent damage in other parts of the structure.

#### 6.2 DUCTILE SUBSTRUCTURES

##### 6.2.1 General

Inelastic deformation of steel girder bridges under the *DSH* shall be limited to substructures. Ductile steel substructures shall be designed in accordance with Chapter 5. Ductile concrete substructures shall be designed in accordance with provisions specified in the *SDC*. End cross frames shall be designed to remain essentially elastic. Integral connections between steel girder superstructures and concrete substructures shall be designed in accordance with Article 6.5.

##### 6.2.2 End Cross Frames

Force demands on the end cross frames shall be determined by the overstrength shears corresponding to the overstrength plastic moments of the substructure components.

The expected nominal strength of the end cross frames shall be determined in accordance with appropriate provisions in Section 6 of the *AASHTO BDS*, except that  $F_{ye}$  is used in lieu of  $F_y$ .

## 6.3 DUCTILE END CROSS FRAMES

### 6.3.1 General

A ductile end cross frame (*DECF*) shall be a *CBF* or a *EBF*, or a specially designed system. Inelastic deformation of steel bridges in the transverse direction under the *DSH* shall be limited to the ductile members in the *DECF*. All other components, including the substructure components, shall be designed to remain essentially elastic in the transverse direction.

*DECF* should only be used when all the following conditions are satisfied:

- Peak ground acceleration less than 0.4g,
- Straight steel girder bridges,
- Skew angle less than 10 degrees,
- Equally spaced steel girders.

### 6.3.2 Displacement Capacities

Displacement of a *DECF* shall be the relative lateral displacement between the deck (or the top chord) and the bottom of the girder. Displacement capacity of a *DECF* shall be determined by *ISA* specified in Article 3.1. Expected material properties shall be used in the analysis. For bearing stiffeners bolted to the web, the effective column section shall be taken as the stiffener elements only. For stiffeners welded to the web, the effective column section shall be taken as all stiffener elements, plus a centrally located strip of web extending not more than  $9t_w$  on each side of the outer projecting elements of the stiffener group. For elastomeric bearings, the bottom of the effective columns should be assumed pinned while the top of the columns may be assumed fixed. For steel bearings, the bottom of the effective column shall be modeled carefully based on the actual conditions.

### C6.3.1

End cross frames or diaphragms in slab-on-steel girder bridges may be designed as ductile systems for better inelastic performance and energy dissipation capacity to limit the seismic forces transferred to the substructure in the transverse direction. *DECF* systems are generally more effective in longer span bridges and may not be as effective for short span bridges when the superstructure is significantly stiffer than the substructure (Alfawakhiri and Bruneau, 2001).

The provisions in this Article are based on research conducted by Zahrai and Bruneau (1998, 1999a and 1999b), Carden et al. (2006), Bahrami et al. (2010), Fehling et al. (1992), Nakashima (1995), Uang, et al. (2014), Monzon, et al. (2014) and the design requirements for *CBF* and *EBF* in the *AISC Seismic Provisions* (AISC, 2010a). A design procedure including modeling with design examples of steel girder bridges with *DECF* is provided by Monzon, et al. (2014). The bi-directional *BRB* for implementation in straight and skewed bridge superstructures was reported by Wei and Bruneau (2015).

### C6.3.2

Boundary conditions of the effective columns depend on the bearing details and on the bending stiffness of the tributary length of deck about the longitudinal bridge axis. It may be conservative to consider the top fixed to allow the maximum contribution as an upper bound to the stiffness of the effective columns. A finite element analysis indicates that the contribution of the effective columns is around five percent in the elastic range; while the relative contribution will be significant when the cross frames yield (Zahrai and Bruneau, 1998).

The lateral displacement capacity of a steel girder bridge in the transverse direction shall include the displacement capacity of the *DECF*, the displacement of the bearings and the displacement of the substructures under a lateral force corresponding to the overstrength lateral load force of the *DECF* when all braces are assumed to reach their expected nominal strength in compression or in tension. Displacements of substructures shall be based on effective section properties as specified in Article 3.2.5 for steel, and in Article 5.6 of the *SDC* for concrete.

### 6.3.3 Force Demands on Substructures

Force demands on substructures shall be taken as the larger of the forces determined from the following two analyses:

- An analysis of *DECF* in which all braces in *DECF* are assumed to resist their overstrength forces in compression or in tension.
- An analysis of *DECF* in which all braces in tension are assumed to resist their overstrength tensile forces and all braces in compression to resist their overstrength post-buckling forces.

### 6.3.4 Concentrically Braced Frames

#### 6.3.4.1 General

*DECF* shall consist of X-type or inverted V-type diagonal braces with top and bottom chords.

#### C6.3.4.1

Figure C6.3.4.1-1 shows inverted V-type diagonal braces with top and bottom chords.

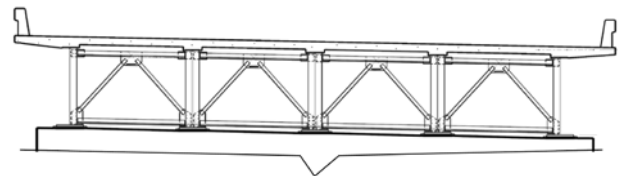

**Figure C6.3.4.1-1 An Inverted V-Type Cross Frame**

#### 6.3.4.2 Force Demands

##### (1) Brace Connections

Force demands on brace connections shall be taken as the overstrength force of the brace in compression, tension, flexure and shear respectively. These forces are permitted to be considered independently without interaction.



## (2) Top Chords

The axial force demand shall be taken as the horizontal component of the overstrength forces of the diagonal brace in tension.

The vertical force demand at the intersection of diagonal braces in the inverted V-type shall be taken as the unbalanced vertical force determined by using the overstrength force of the brace in tension and the overstrength post-buckling force of the brace as specified in Article 6.3.4.3.

### 6.3.4.3 Diagonal Braces

### C6.3.4.3

#### (1) General

Braces shall be single-angle or double-angle members. Braces shall satisfy the requirements of ductile diagonal braces as specified in Articles 4.2 and 4.3. The brace effective net area shall not be less than the brace gross area. When reinforcement on braces is used, the following requirements shall be satisfied:

- The specified minimum yield strength of the reinforcement shall not be less than the specified minimum yield strength of the brace.
- The connections of the reinforcement to the brace shall be designed for the force corresponding to the expected nominal reinforcement strength on each side of a reduced area.

#### (2) Overstrength Force

The overstrength force of a brace shall be taken as its idealized plastic strength multiplied by an overstrength factor,  $\Omega$  as specified in Article 2.6.3.

#### (3) Idealized plastic strength

The idealized plastic strength of a brace shall be taken as its expected nominal strength multiplied by a factor 1.17.

The 1.17 factor in the idealized plastic strength accounts for the strain hardening at the significant damage level specified in Article 2.5.

#### (4) Expected Nominal Strength

The expected nominal strength of a brace in compression shall be determined in accordance with Article 6.9.4 of the *AASHTO BDS*, except that  $F_{ye}$  is used in lieu of  $F_y$ .

The expected nominal post-buckling strength of a brace shall be taken as 0.3 times its expected nominal strength in compression.

The expected nominal strength of a brace in tension shall be taken as  $F_{ye}A_g$ .

#### (5) Double-Angle Braces

For double-angle bracing members, the slenderness ratio of the individual elements between the connectors shall not be greater than 0.4 times the governing slenderness ratio of the built-up members as a whole. Connectors shall be designed for the expected nominal tensile strength of each element. Spacing of connectors shall be uniform and not less than two connectors shall be used. Connectors shall not be located within the middle one-fourth of the clear brace length. When buckling of braces about their critical buckling axis does not cause shear in the connectors, the spacing of the connectors shall be such that the slenderness ratio of the individual element between the connectors does not exceed three-fourths the governing slenderness ratio of the built-up member.

#### (6) Plastic Regions

Plastic regions for a brace shall be the center one-quarter of the brace length and a zone adjacent to each connection equal to the brace depth in the plane of buckling.

#### 6.3.4.4 Top Chords

Top chords shall be single-angle or double-angle members. Top chords shall be connected to a concrete deck by shear connectors as specified in Article 6.7. The top chord shall satisfy requirements of capacity-protected members as specified in Articles 4.2 and 4.3. The expected nominal flexural strength of a top chord shall be determined in accordance with Articles 6.12 of the *AASHTO BDS*, except that  $F_{ye}$  is used in lieu of  $F_y$ . The expected nominal strength of a top chord in tension shall be taken as  $F_{ye}A_g$ .

#### 6.3.5 Eccentrically Braced Frames

*EBF* shall be designed in accordance with Article 5.3



## 6.4 SEISMICALLY ISOLATED BRIDGES

### 6.4.1 General

Inelastic deformations of seismically isolated steel girder bridges under the *DSH* shall be limited to seismic isolation bearings. All other components, including substructures and end cross frames, shall be designed to remain essentially elastic.

### 6.4.2 Seismic Isolation Bearings

Seismic isolation bearings shall be designed in accordance with the *AASHTO Guide Specifications for Seismic Isolation Design* (AASHTO, 2014).

### 6.4.3 Force Demands

Force demands on substructures, end cross frames and shear connectors shall be based on the maximum force allowed to be transferred by the isolators.

## 6.5 INTEGRAL CONNECTION SYSTEMS

### 6.5.1 General

Integral connections between steel girder superstructures and concrete substructures shall be appropriately detailed and designed to resist seismic loads and displacements. Integral connection systems shall apply to composite steel I-girder superstructures.

### C6.4.1

The state of the practice and implementation of seismic isolation in bridge structures are discussed by Imbsen and Wu (2014). Fourteen examples of precast concrete girder and steel I-girder bridges are developed to demonstrate the application of isolation for varying seismic hazard, site classification, and isolator types by Buckle, et al. (2012).

### C6.5.1

Integral connections for steel girder bridges make the entire structure act as one system to resist loads and result in more economical foundations.

The integral connection systems may be effective for short span bridges. Use of this system also increases vertical clearance and provides improved aesthetics. The provisions are based on research of integral concrete bent cap connection conducted by Patty et al (2001). Integral steel box bent cap design requirements can be found in Wassef et al (2004).

For integral concrete bent caps and concrete diaphragms with steel girders, web stiffeners are more effective to transfer torsion than shear studs welded onto the girder web.

## 6.5.2 Steel Girder Superstructures

### 6.5.2.1 General

Steel girder flanges should be located outside the width of the column. Any two steel girders next to a substructure column shall be spaced symmetrically with respect to the column.

### 6.5.2.2 Force Demands

Force demands on steel girder superstructures shall be generated by the overstrength plastic moment  $M_o^{col}$  of the concrete columns as specified in Article 4.3.1 of the *SDC*.

### 6.5.2.3 Expected Nominal Strength

The expected nominal strength of a steel girders shall be determined in accordance with Articles 6.10 of the *AASHTO BDS*, except that  $F_{ye}$  is used in lieu of  $F_y$ . Steel-concrete composite action of the superstructure can be considered only if adequate shear studs are provided in accordance with Article 6.10.10 of the *AASHTO BDS*.

The effective superstructure width resisting longitudinal seismic moments and shears generated by a concrete column shall be the sum of the column cross-sectional dimension in the transverse direction and the depth of the superstructure in accordance with Article 7.2.1.1 of the *SDC*. A wider effective width may be used if the bent cap is designed in accordance with Article 6.5.4.

## 6.5.3 Concrete Columns

Concrete columns shall be designed as ductile members in accordance with the *SDC*.

## 6.5.4 Concrete Bent Cap Beams

When an effective superstructure width wider than that specified in Article 6.5.2.3 is used, concrete cap beams shall be designed to resist torsional moments generated by overstrength plastic moment,  $M_o^{col}$  of the concrete column. The expected nominal torsion resistance of the concrete cap beam shall be determined in accordance with Article 5.8.3.6 of the *AASHTO BDS*, except that  $F_{ye}$  is used in lieu of  $F_y$ .

### C6.5.4

Integral concrete bent cap testing results (Patty et al. 2001) demonstrated that:

- Stiffeners on the girder web within the cap beam region increased the maximum capacity of the connection by providing a confining effect to the concrete cap.

## 6.6 CONCRETE END DIAPHRAGMS AT ABUTMENTS

Concrete end diaphragms may be used at the abutments of steel I-girder bridges and shall be continuous with the deck and extended as close as possible to the bottom flange of the girder. The end diaphragm shall be designed to resist the permanent, live, as well as transverse and longitudinal wind and seismic lateral loads. The connection of the diaphragm to the steel girder shall be able to resist the longitudinal seismic soil pressures without the girder punching through it. The connection shall include continuous reinforcement that is placed both behind the girder and placed through drilled holes in the girder web near the front face of the diaphragm for flexural moments. Stud connectors shall be welded to the girder web to resist longitudinal shear and punching forces.

## 6.7 SHEAR CONNECTORS

Shear connectors shall be provided within the center two-thirds of the top chords of the end cross frames and on the top flanges of girders to transfer seismic loads from the concrete deck to the abutments or pier supports.

- Post-tensioning the cap beam increased the initial capacity and decreased the damage level during the initial loading stage but did not increase the ultimate moment and rotation capacities. The detail is much less congested than conventional reinforced concrete cap beams.

### C6.6

Concrete end diaphragms are preferred over steel cross frames due to their ability to better mobilize the soil behind the abutment thus reducing seismic loads to the columns.

### C6.7

The cross frames or diaphragms at the end of each span are the main components to transfer the lateral seismic loads from the deck down to the bearing locations. Tests on a 0.4 scale experimental steel girder bridge of 60 ft long (Carden et al., 2006b) indicated that inadequate shear connectors between the girders and deck at the bridge end did not allow the end cross frame to reach its ultimate capacity. Supporting numerical analysis on a continuous multi-span bridge showed that, for non-composite negative moment regions, the absence of shear connectors at the end of a bridge span caused large weak-axis bending stresses in the girders that are likely to cause buckling or yielding of the girders before the capacity of the ductile component is reached. It is, therefore, recommended that adequate shear connectors be provided to transfer seismic lateral loads.

Improved seismic behavior can be achieved by placing the shear connectors along the central two-thirds of the top chord of the end cross frames. Experiments (Bahrami et al., 2010) showed that this detail minimizes the axial forces on the shear connectors thus improving their cyclic responses.

The effective shear connectors in the transverse direction should be taken as those located on the top chords of end cross frames and the top flanges of girders that are no further away than  $9t_w$  from each side of the outer projecting elements of the bearing stiffener group.

Force demands on shear connectors in the transverse direction at intermediate column/pier supports should be taken as one of the following:

- Shear forces corresponding to the overstrength plastic moments of columns.
- The expected nominal shear strengths of pier walls multiplied by an overstrength factor,  $\Omega$  as specified in Article 2.6.3.
- Force demands on substructures as specified in Article 6.3.3.
- Maximum force allowed to be transferred by isolators.

Force demands on shear connectors in the transverse direction at abutments shall be taken as one of the following:

- The expected nominal shear strengths of the shear keys as specified in Article 7.8.4 of the SDC, multiplied by an overstrength factor,  $\Omega$  as specified in Article 2.6.3.
- Force demands on substructures as specified in Article 6.3.3.
- Maximum force allowed to be transferred by isolators.

The expected nominal strengths of the shear connectors shall be in accordance with Article 6.16.4.3 of the *AASHTO BDS*, except that  $F_{ue}$  is used in lieu of  $F_u$ .

## 6.8 SEAT WIDTH

For simply supported steel girder bridges, the minimum seat width at bent caps shall be determined in accordance with Article 7.2.5.4 of the *SDC*. The minimum seat width at abutments shall be determined in accordance with Article 7.8.3 of the *SDC*.

## 6.9 RESTRAINING COMPONENTS

### 6.9.1 General

Hinge restrainers and/or shear keys shall be provided to prevent excessive lateral movement of the superstructure relative to the substructure.

Hinge restrainers shall be designed as a secondary line of defense against unseating of girders in accordance with Article 7.2.6 of the *SDC*.

When support widths satisfy the requirements of Article 6.8 to tolerate seismic displacements, shear keys may be designed as fuse elements in accordance with Article 7.8.4 of the *SDC*. When excessive seismic displacements must be prevented, shear keys shall be provided and designed as capacity-protected elements.

Concrete shear keys shall be designed in accordance with applicable provisions in the *SDC* and the *AASHTO BDS*. Concrete shear keys that are impacted by relatively thin steel elements such as girder flanges shall be armored with sufficiently thick steel plates or angles to distribute the line load over an area of concrete. Bearing stress on concrete shall not exceed the expected nominal bearing resistance in accordance with Article 5.7.5 of the *AASHTO BDS*, except that  $\phi = 1.0$  and  $F_{ye}$  is used in lieu of  $F_y$ .

Steel pipe shear keys shall be designed in accordance with Article 6.9.2.

### C6.9.1

The extra strong pipe and HSS are the preferred system for interior shear keys as it requires less space and provides more access for future inspection and maintenance.

Figure C6.9-1 shows typical shear keys for a girder bridge.

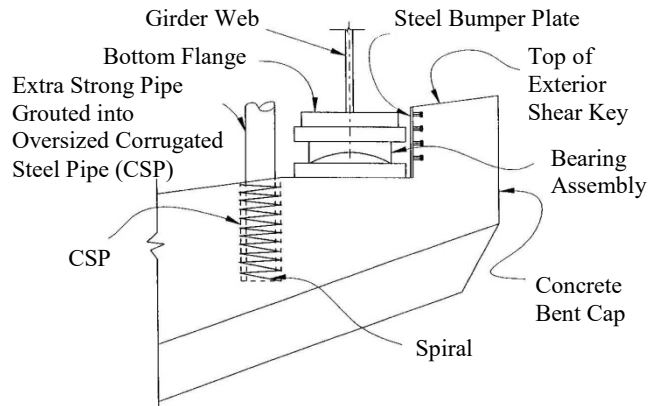

Figure C6.9-1 Typical Shear Keys

### 6.9.2 Steel Pipe Shear Keys

For steel pipe and HSS shear keys, the outside diameter-to-wall thickness ratio of a pipe or a round HSS, and the width-to-thickness ratio of a rectangular HSS web shall not exceed  $2.0\sqrt{E/F_y}$  unless its wall is stiffened or it is concrete filled. The expected nominal shear strength of a steel pipe or a HSS shear key,  $R_{ne}$ , shall be taken as:

$$R_{ne} = 0.58F_{ye}A_g \quad (6.9.2-1)$$

where

$A_g$  = web gross area of a rectangular tube or cross-sectional area of a pipe (in.<sup>2</sup>)

$F_{ye}$  = expected yield strength of steel (ksi)

The steel shear key shall be adequately embedded in the base concrete or positively connected to the base steel.

The pipe embedment lengths may be determined by considering the bearing of the pipe on the concrete and an overstrength factor of 1.25 for the pipe as follows:

$$l_d = \frac{2.1R_{ne}}{f'_c D \sqrt{\frac{A_2}{A_1}}} \quad (6.9.2-2)$$

where

$l_d$  = embedment length of a steel pipe (in.)

$f'_c$  = specified minimum 28-day compressive strength of concrete (ksi)

$D$  = outside diameter of a steel pipe (in.)

$R_{ne}$  = expected nominal shear strength of a steel pipe or a HSS shear key (kip)

$A_1$  = bearing area of a steel pipe in concrete (in.<sup>2</sup>)

$A_2$  = confinement concrete area equal to the embedment length of a steel pipe times the concrete edge width bound by two 45° lines drawn from the outside diameter of the pipe to the edge of concrete element (in.<sup>2</sup>)

$\sqrt{A_2/A_1}$  = confinement factor not more than 2.

### C6.9.2

The limiting width-to-thickness ratio of  $2.0\sqrt{E/F_y}$  is taken as 80% of the limiting slenderness ratio of an unstiffened web,  $2.5\sqrt{E/F_y}$ , for shear yielding (AASHTO, 2012) to allow full yielding of a pipe or a HSS. Experiments of pipe shear keys (Zaghi and Saiidi, 2010) showed that the limit states under lateral loading would be the pure shear failure of the infilled pipe or bearing failure of the concrete.

Steel pipe shear key tests reported by Frosch (1999) showed that proper embedment was required to produce shear yielding of the pipe.

In deriving Equation 6.9.2-2, the design bearing strength of concrete is based on  $\phi(0.85 f'_c) = 0.7(0.85 f'_c)$



## 6.10 BEARING ASSEMBLIES

### 6.10.1 General

A bearing assembly includes bearings, anchorages and shear keys. Anchor bolts or rods shall be generally designed to resist seismic uplift and shear keys shall be mainly designed to resist lateral seismic loads, respectively. Anchorages shall be designed in accordance with Article 7.7.

### 6.10.2 Force Demands

Force demands on a bearing assembly in the transverse direction at intermediate column/pier supports should be taken as one of the following:

- Shear forces corresponding to the overstrength plastic moments of columns.
- The expected nominal shear strengths of pier walls multiplied by an overstrength factor,  $\Omega$  as specified in Article 2.6.3.
- Force demands on substructures as specified in Article 6.3.3.

Force demands on a bearing assembly in the longitudinal direction at intermediate column/pier supports should be taken as the expected nominal shear strength of columns/piers, multiplied by an overstrength factor,  $\Omega$  as specified in Article 2.6.3.

Shear keys at abutments shall be designed in accordance with Article 7.8.4 of the *SDC*.

### 6.10.3 Expected Nominal Strength

The expected nominal strength of a concrete shear key at the intermediate column/pier supports shall be determined in accordance with Article 5.8.4 of the *AASHTO BDS*, except that  $f_{ye}$  is used in lieu of  $f_y$ , where  $f_{ye}$  and  $f_y$  are the expected yield strength and specified minimum yield strength of reinforcing steel, respectively, as specified in Article 3.2.3 of the *SDC*.

The expected nominal strength of a steel pipe shear key shall be determined in accordance with Article 6.9.2.

## CHAPTER 7

### CONNECTIONS AND SPLICES

This chapter addresses seismic design requirements for connections and splices.

#### 7.1 GENERAL

The design strength of a connection for ductile members shall not be less than the effect of the overstrength force of a ductile member combined with the associated design forces of the other members, with each ductile member considered separately.

The design strength of a connection for capacity-protected members shall not be less than the effect of the design strength of a capacity-protected member combined with the associated design forces of the other members, with each capacity-protected member considered separately.

The design strength of a splice for ductile members shall not be less than the smaller overstrength force of the spliced members.

The design strength of a splice for capacity-protected members shall not be less than the smaller design strength of the spliced members.

#### 7.2 BEAM-TO-COLUMN CONNECTIONS

The expected nominal strengths of a connection shall be determined in accordance with Articles 6.13.2 and 6.13.3 of the *AASHTO BDS*, except that the expected material properties are used in lieu of the specified minimum material properties.

The expected nominal shear strength of the panel zone as shown in Figure C7.2-1,  $V_{ne}$ , shall be taken as:

$$V_{ne} = 0.58F_y d_g t_p \quad (7.2-1)$$

where

$d_g$  = overall girder depth (in.)

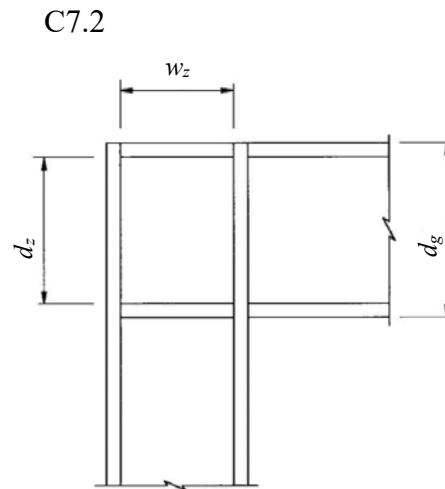

Figure C7.2-1 A Typical Panel Zone

$t_p$  = total thickness of the panel zone including doubler plates (in.)

The panel zone thickness,  $t_p$ , shall satisfy the following requirement:

$$t_p \geq \frac{d_z + w_z}{90} \quad (7.2-2)$$

where

$d_z$  = panel zone depth between continuity plates (in.)

$w_z$  = panel zone width between column flanges (in.)

### 7.3 BRACE CONNECTIONS

The expected nominal strength of a gusset plate shall be determined in accordance with Article 7.5.

The brace shall be terminated on the gusset a minimum distance of two times the gusset thickness from a line perpendicular to the brace axis about which the gusset plate may bend unrestrained by the beam, columns, or other brace joints.

The flexural strength of a single plate connection about the brace buckling out of the gusset plate plane need not be checked when the braced connections meet the requirements in the above paragraph.

### C7.3

Testing (Astaneh et al., 1986) has shown that where a single gusset plate connection is used, the rotation at the end of a brace can be accommodated as long as the brace end is separated by at least two times the gusset thickness from a line perpendicular to the brace centerline, drawn from the point on the gusset plate nearest to the brace end that is constrained from out-of-plane rotation (see Figure C7.3-1). The effect of end fixity should be considered in determining the critical buckling axis if rigid end conditions are used for in-plane buckling, and pinned connections are used for out-of-plane buckling. More information on seismic design of gusset plates can be obtained from Astaneh (1998).

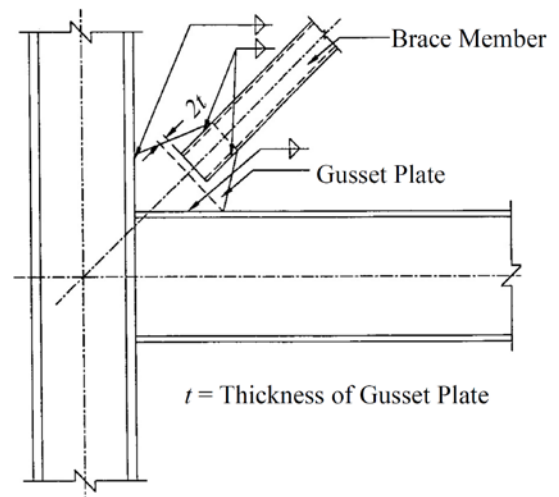

Figure C7.3-1 Brace-to-Gusset Plate Requirement

## 7.4 SPLICES

Ductile members shall not be spliced in plastic regions. The expected nominal strength of a splice plate shall be determined in accordance with Article 7.5.

## 7.5 CONNECTION ELEMENTS

### 7.5.1 General

This Article shall apply to the design of connection elements such as splice plates and gusset plates. The expected nominal strength of the connection elements shall be based on the effective width as shown in Fig. C7.5.1-1. The gross area,  $A_g$ , and the net area,  $A_n$ , shall be limited to the effective width.

### C7.5.1

Figure C7.5.1-1 shows the effective width for a connection plate in accordance with Whitmore section (Whitmore, 1952). The effective width is determined at the end of the joint by spreading the force from the start of the joint  $30^\circ$  to each side in the connection element along the line of force. The effective width may spread across the joint between connection elements, but cannot spread beyond an unconnected edge (AISC, 2011). A comprehensive discussion on seismic design of gusset plates can be found in Astaneh (1998). The latest development on the gusset plate connections for steel bridges can be found in Astaneh (2010) and Ocel (2013).

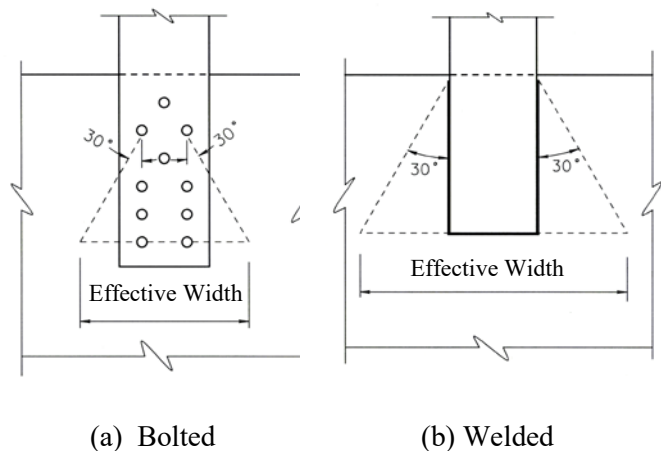

**Figure C7.5.1-1 Effective Width of Connection Plate**

### 7.5.2 Limiting Unsupported Edge Length to Thickness Ratio

The unsupported edge length to thickness ratio of a gusset plate shall satisfy:

$$\frac{L_g}{t} \leq 2.06 \sqrt{\frac{E}{F_y}} \quad (7.5.2-1)$$

### C7.5.2

Equation 7.5.2-1 is specified in Article 6.14.2.8 of the *AASHTO BDS*.

where

$L_g$  = unsupported edge length of a gusset plate (in.)

$t$  = thickness of a gusset plate (in.)

When  $L_g/t$  is larger than  $1.6\sqrt{E/F_y}$ , the compression stress of a gusset plate shall be less than  $0.8F_y$ . Otherwise, the plate shall be stiffened.

For stiffened edge, the following requirements shall be satisfied:

- For welded stiffeners, the slenderness ratio of the stiffener plus a width of gusset plate equal to ten times its thickness shall be  $l/r \leq 40$ .
- For bolted stiffeners, the slenderness ratio of the stiffener between fasteners shall be  $l/r \leq 40$ .
- The moment of inertia of the stiffener shall satisfy:

$$I_s \geq \begin{cases} 1.83t^4 \sqrt{(b/t)^2 - 144} \\ 9.2t^4 \end{cases} \quad (7.5.2-2)$$

where

$I_s$  = moment of inertia of a stiffener about its strong axis (in.<sup>4</sup>)

$b$  = width of a gusset plate perpendicular to the edge (in.)

$t$  = thickness of a gusset plate (in.)

### 7.5.3 Expected Nominal Tensile Strength

The expected nominal tensile strength of a connection element for ductile members,  $P_{ne}$ , shall be taken as:

$$P_{ne} = P_{nye} \leq \begin{cases} \phi_u P_{nue} \\ \phi_{bs} P_{bse} \end{cases} \quad (7.5.3-1)$$

where

$P_{bse}$  = expected nominal strength for block shear rupture determined in accordance with Article 6.13.4 of the *AASHTO BDS*, except that  $F_{ye}$  and  $F_{ue}$  are used in lieu of  $F_y$  and  $F_u$ , respectively (kip)

The limit of  $1.6\sqrt{E/F_y}$  is set forth in Caltrans *San Francisco-Oakland Bay Bridge West Span Seismic Retrofit Design Criteria* (Caltrans, 1997) and validated by Itani et al. (1998). Although there appears to be no correlation to the buckling strength using the free edge slenderness based on Ocel's study (2013), the check leads to a conservative detail and adds safety for any initial edge imperfections.

The moment of inertia of the stiffener that is required to develop the post buckling strength of a long plate was experimentally determined by Equation 7.5.2-2 (AISI, 1962).

### C7.5.3

This requirement ensures that the tensile strength of a connection element for ductile members is governed by yielding in the gross section, and that fracture in the net section and block shear rupture are prevented.

- $P_{nue}$  = expected nominal tensile strength for fracture in net section determined in accordance with Article 6.8.2.1 of the *AASHTO BDS* except that  $F_{ue}$  is used in lieu of  $F_u$  (kip)
- $P_{nye}$  = expected nominal tensile strength for yielding in gross section as specified in Article 6.8.2.1 of the *AASHTO BDS* except that  $F_{ye}$  is used in lieu of  $F_y$  (kip)
- $\phi_{bs}$  = resistance factor for block shear as specified in Article 2.6.4
- $\phi_u$  = resistance factor for fracture in the net section as specified in Article 2.6.4

The design tensile strength of a connection element for capacity-protected members shall be the lowest value of the factored expected nominal tensile strength for yielding in gross section,  $\phi P_{nye}$ , for fracture in net section,  $\phi_u P_{nue}$ , and for block shear rupture,  $\phi_{bs} P_{bse}$ .

#### 7.5.4 Expected Nominal Compressive Strength

The expected nominal compressive strength of a connection element,  $P_{ne}$ , shall be determined in accordance with Article 6.9.4.1 of the *AASHTO BDS*, except that  $F_{ye}$  is used in lieu of  $F_y$ .

#### C7.5.4

Effective length factor,  $K$ , may be taken as 0.6 for a gusset supported by both edges, and 1.2 for a gusset supported by one edge only (AISC, 2001);  $A_g$  is the average effective cross section area limited by Whitmore section;  $l$  is the distance from the Whitmore section perpendicular to the interior corner of the gusset. For members that are not perpendicular to each other as shown in Figure C7.5.4-1 (AISC, 2001),  $l$  can be alternatively determined as the average value of

$$l = \frac{L_1 + L_2 + L_3}{3} \quad (C7.5.4-1)$$

where

- $L_1$  = distance from the centerline of the Whitmore section to the interior corner of a gusset plate (in.)
- $L_2, L_3$  = distance from the outside corner of the Whitmore section to the edge of a member; a negative value shall be used when the part of Whitmore section enters into the member (in.)

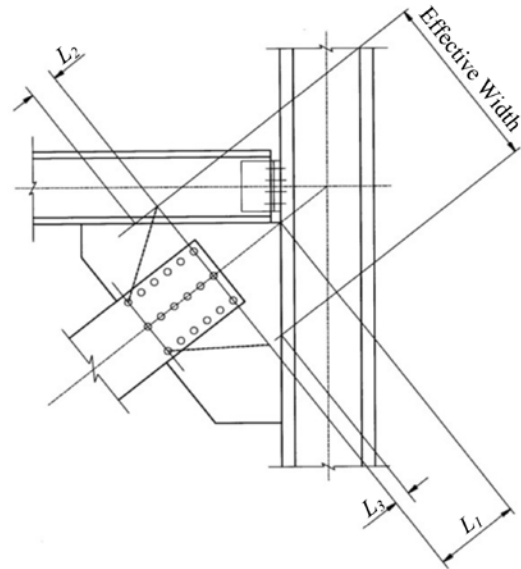

**Figure C7.5.4-1 Gusset Plate Connection**

When lateral sway of gusset plates is possible, the effective length factor,  $K$ , for gusset plates may be taken from Table C4.6.2.5.-1 of the *AASHTO BDS* for Cases (d), (e), or (f), depending on the anticipated buckled shape. When lateral sway of gusset plates is not possible, the effective length factor,  $K$ , for gusset plates may be taken from Table C4.6.2.5.-1 for Cases (a), (b), or (c), as appropriate.

### 7.5.5 Expected Nominal Flexural Strength

The expected nominal flexural strength of a connection element about the strong axis (in-plane),  $M_{ne}$ , shall be determined by:

$$M_{ne} = ZF_{ye} \quad (7.5.5-1)$$

where

$Z$  = plastic section modulus about the strong axis of the cross section of a connection element (in.<sup>3</sup>)

### 7.5.6 Expected Nominal Shear Strength

The expected nominal shear strength of a connection element,  $V_{ne}$ , shall be taken as:

$$V_{ne} = \text{smaller of } \begin{cases} 0.58 F_{ye} A_{vg} \\ 0.58 \phi_u A_{uv} \end{cases} \quad (7.5.6-1)$$

where

- $A_{vg}$  = gross area subject to shear (in.<sup>2</sup>)
- $A_{vn}$  = net area subject to shear (in.<sup>2</sup>)
- $\phi_u$  = resistance factor for fracture in the net section as specified in Article 2.6.4

### 7.5.7 Combined Flexural, Shear and Axial Forces

Gusset plates connecting ductile members subject to combined in-plane flexural, shear and axial forces shall satisfy the following relationship:

$$\frac{M_{ua}}{M_{ne}} + \left(\frac{P_{ua}}{P_{ne}}\right)^2 + \frac{\left(\frac{V_{ua}}{V_{ne}}\right)^4}{\left[1 - \left(\frac{P_{ua}}{P_{ne}}\right)^2\right]} \leq 1.0 \quad (7.5.7-1)$$

where

- $M_{ne}$  = expected nominal flexural strength determined by Article 7.5.5 (kip-in.)
- $M_{ua}$  = moment demand simultaneously associated with axial and shear forces (kip-in.)
- $P_{ua}$  = axial force demand simultaneously associated with moment and shear forces (kip)
- $P_{ne}$  = expected nominal tensile or compressive strength determined by Articles 7.5.3 and 7.5.4, respectively (kip)
- $V_{ne}$  = expected nominal shear strength determined by Article 7.5.6 (kip)
- $V_{ua}$  = shear force demand associated simultaneously with axial and flexural forces (kip)

### 7.5.8 Out-of-Plane Force Consideration

For double gusset plate connections, out-of-plane moments shall be resolved into a couple of tension and compression forces acting on the near and far side gusset plates. Separate shear connections shall be provided to resist out-of-plane shear.

For single gusset plate connections, out-of-plane moment and shear are about the weak axis of the gusset plate.

### C7.5.7

Connection elements have traditionally been designed for simple stress states, such as tension, compression, shear or flexure without considering interaction. This simplification is adequate because connection elements are usually small or short enough that an interaction-type distribution cannot be formed (AISC, 2011). For gusset plates connecting ductile members, Equation 7.5.7-1 ensures that the capacity design principle for the gusset plate connecting ductile members is satisfied. Equation 7.5.7-1 was modified from the full yield interaction equation for a rectangular plate subjected to the combined flexural, shear and axial forces (Neal, 1961; ASCE, 1971) based on the von Mises criterion. The *M-P-V* interaction equation was first used in the Caltrans *San Francisco-Oakland Bay Bridge West Span Seismic Retrofit Design Criteria* (Caltrans, 1997) and then adopted in the *California Amendments* (Caltrans, 2008).



## SPECIFICATIONS

## COMMENTARY

**7.6 FASTENERS AND HOLES**

The expected nominal strength of a fastener for shear, tension and combined shear and tension shall be based on bearing-type connections in accordance with Article 6.13.2 of the *AASHTO BDS*, except that  $F_{ye}$  and  $F_{ue}$  are used in lieu of  $F_y$  and  $F_u$ , respectively.

The expected nominal bearing capacities on fastener holes shall be determined in accordance with Article 6.13.2.9 of the *AASHTO BDS*, except that  $F_{ue}$  is used in lieu of  $F_u$ .

Additional tension forces resulting from prying action must be accounted for in determining the applied loads on fasteners. The connected elements (primarily angles) must also be checked for adequate flexural strength.

**7.7 ANCHOR BOLTS**

Steel superstructures and columns shall be anchored with sufficient capacity to transfer the lateral force demands to substructures or foundations. Anchor bolts or rods shall be designed to resist seismic uplift and shear keys shall be designed to resist lateral seismic loads, respectively.

Yielding of the anchor bolts shall be the governing failure mode. A brittle concrete tensile failure shall be prevented. Edge distance and embedment length of anchor rods shall be such that a ductile failure occurs. Concrete failure surfaces shall be based on a shear stress of  $2\sqrt{f'_c}$  ( $f'_c$  in psi) and account for edge distances and overlapping shear zones.

The expected nominal tensile strength of anchor bolts shall be determined in accordance with Articles 6.13.2.10 of the *AASHTO BDS*, except that  $F_{ue}$  is used in lieu of  $F_u$ .

When anchor bolts (or rods) are required to resist a tensile force, headed anchor bolts shall be used. Hooked anchor bolts shall not be used for superstructure anchorages. Quenched and tempered anchor bolts shall not be welded.

**C7.6**

Prying action forces may be determined from the equations presented in the *AISC Manual* (AISC, 2010c). Since the seismic design is an extreme limit state, bearing capacities of fasteners and holes are used for both the ductile and capacity-protected components.

Since the seismic design is an extreme limit state, bearing capacities of fasteners and holes are used for both the ductile and capacity-protected components.

**C7.7**

The *AISC Manual* (AISC, 2014c) Part 14 provides the minimum edge distance and embedment length for typical anchor rods. The *PCI Design Handbook* (PCI, 2010) presents a method of calculating strength of embedded bolts and rods. The ACI 318-14 (ACI, 2014) provides the latest requirements for anchoring to concrete.

## APPENDIX A

### STRESS-STRAIN RELATIONSHIPS FOR STRUCTURAL STEEL

This appendix presents stress-strain relationships of structural steel for the use in a seismic analysis.

For structural steel, its expected stress-strain relationship under a monotonic loading can be idealized with four parts: elastic, plastic, strain hardening and softening as shown in Figure A-1.

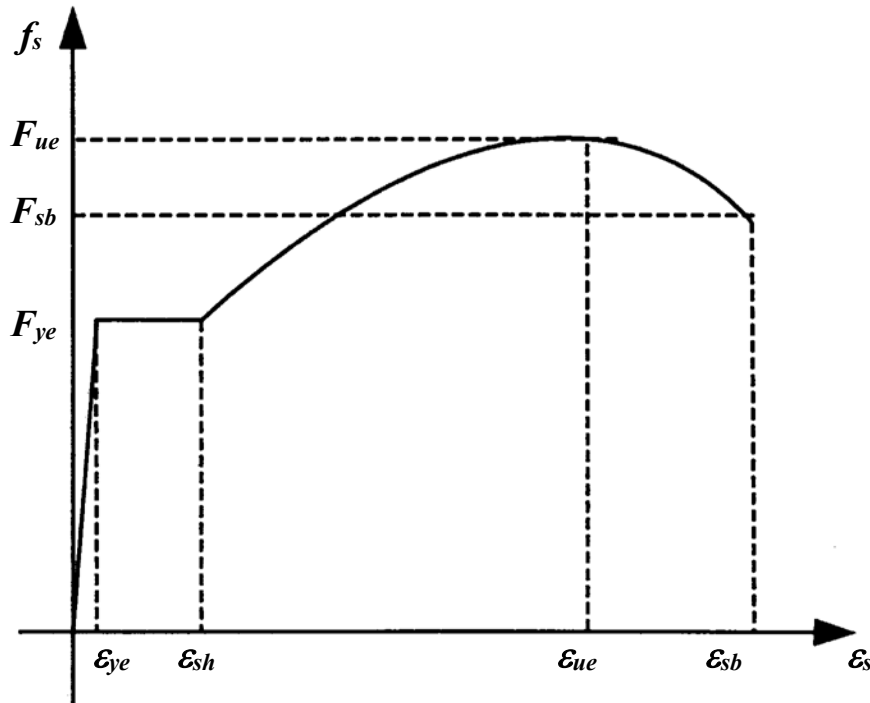

**Figure A-1 Idealized Expected Stress-Strain Curve for Structural Steel**

The simplest multi-linear expression for an idealized stress-strain curve of structural steel is:

$$f_s = \begin{cases} E\varepsilon_s & 0 \leq \varepsilon_s \leq \varepsilon_{ye} \\ F_{ye} & \varepsilon_{ye} < \varepsilon_s \leq \varepsilon_{sh} \\ F_{ye} + \frac{\varepsilon_s - \varepsilon_{sh}}{\varepsilon_{ue} - \varepsilon_{sh}} (F_{ue} - F_{ye}) & \varepsilon_{sh} < \varepsilon_s \leq \varepsilon_{ue} \\ F_{ue} - \frac{\varepsilon_s - \varepsilon_{ue}}{\varepsilon_{sb} - \varepsilon_{ue}} (F_{ue} - F_{sb}) & \varepsilon_{ue} < \varepsilon_s \leq \varepsilon_{sb} \end{cases} \quad (A-1)$$

where

- $f_s$  = stress in steel (ksi)
- $\epsilon_s$  = strain in steel
- $E$  = modulus of elasticity of steel = 29,000 (ksi)
- $F_{ye}$  = expected yield strength of steel (ksi)
- $\epsilon_{ye}$  = strain corresponding to the expected yield strength of steel
- $\epsilon_{sh}$  = strain at the onset of strain hardening of steel
- $F_{ue}$  = expected tensile strength of steel (ksi)
- $\epsilon_{ue}$  = strain corresponding to the expected tensile strength of steel
- $F_{sb}$  = rupture stress of steel (ksi)
- $\epsilon_{sb}$  = rupture strain of steel

For both strain-hardening and softening portions, the following expression proposed by Holzer et al. (1975) may be used.

$$f_s = F_{ye} \left[ 1 + \left( \frac{F_{ue}}{F_{ye}} - 1 \right) \left( \frac{\epsilon_s - \epsilon_{sh}}{\epsilon_{ue} - \epsilon_{sh}} \right) \exp \left( 1 - \frac{\epsilon_s - \epsilon_{sh}}{\epsilon_{ue} - \epsilon_{sh}} \right) \right] \quad \text{for } \epsilon_{sh} < \epsilon_s \leq \epsilon_{sb} \quad (\text{A-2})$$

The expected limiting values for stress and strain curves are shown in Table A-1. Strains,  $\epsilon_{sh}$ ,  $\epsilon_{ue}$  and  $\epsilon_{sb}$ , and rupture stress  $F_{sb}$  are obtained from coupon tests at University of California at San Diego and University of Nevada at Reno.

**Table A-1 Expected Values for Steel Stress-Strain Curves**

Steel Grade	$F_{ye}$ (ksi)	$F_{ue}$ (ksi)	$F_{sb}$ (ksi)	$\epsilon_y$	$\epsilon_{sh}$	$\epsilon_{ue}$	$\epsilon_{sb}$
A709 Grade 50 (Plate)	55.0	78.0	75.8	0.00190	0.01982	0.14458	0.24052
A709 Grade 36 (Plate)	46.8	69.6	58.2	0.00161	0.01898	0.16696	0.28490
A709 Grade 36 (Rolled Shape)	54.0	69.6	54.0	0.00186	0.03156	0.20605	0.34866

## APPENDIX B

### EFFECTIVE SECTION PROPERTIES OF LATTICED MEMBERS

This appendix presents formulas of effective section properties for latticed members as shown in Figure B-1 for possible use in a seismic analysis (Duan et al., 2000).

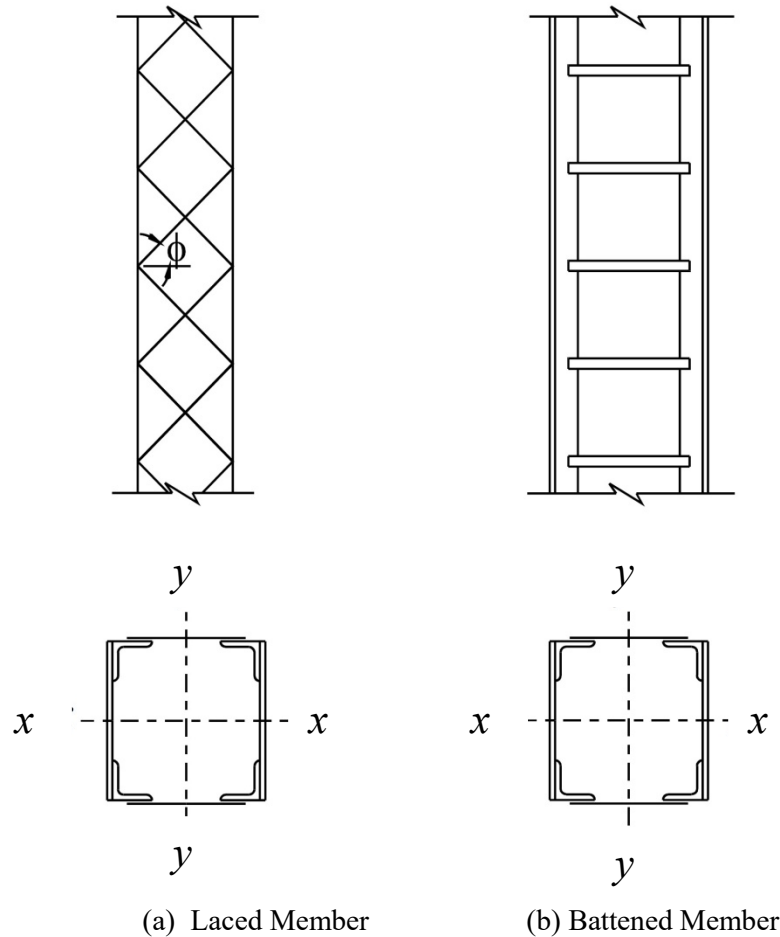

**Figure B-1 Typical Latticed Members**

#### B.1 Cross-sectional Area - $A$

The contribution of lacing bars for carrying vertical load is assumed negligible. The cross-sectional area of a latticed member is based only on individual main components which can be either a whole angle or a plate.

$$A = \sum A_i \tag{B.1-1}$$

where

$A_i$  = cross-sectional area of an individual main component  $i$  (in.<sup>2</sup>)

## B.2 Moment of Inertia - *I*

### B.2.1 Lacing Bars or Battens in Plane of Web (Bending about *y-y* Axis in Figure B-1)

$$I_{y-y} = \sum I_{(y-y)i} + \beta_m \sum A_i x_i^2 \quad (\text{B.2.1-1})$$

where

- $I_{y-y}$  = moment of inertia about the *y-y* axis (in.<sup>4</sup>)
- $I_i$  = moment of inertia of a main individual component *i* (in.<sup>4</sup>)
- $x_i$  = distance between the *y-y* axis and the centroid of the main individual component *i* (in.)
- $\beta_m$  = reduction factor for the moment of inertia

#### **For laced member (Figure B-1a)**

$$\beta_m = \frac{m \sin \phi \times \text{smaller of } \begin{cases} m_l (P_n^{comp} + P_n^{ten}) \\ m_l n_r A_r (0.6F_u) \end{cases}}{F_{yf} A_f} \leq 1.0 \quad (\text{B.2.1-2a})$$

#### **For battened member (Figure B-1b)**

$$\beta_m = \frac{m \times \text{smaller of } \begin{cases} m_b A_b (0.6F_{yw}) \\ m_b (2M_{p-b} / h) \\ m_b n_r A_r (0.6F_u) \end{cases}}{F_{yf} A_f} \leq 1.0 \quad (\text{B.2.1-2b})$$

where

- $\phi$  = angle between a diagonal lacing bar and the axis perpendicular to the member axis (see Figure B-1)
- $A_b$  = cross-sectional area of batten plate (in.<sup>2</sup>)
- $A_f$  = flange area to which battens or laces are attached (in.<sup>2</sup>)
- $F_{yf}$  = specified minimum yield strength of a flange component (ksi)
- $F_{yw}$  = specified minimum yield strength of a web component including battens or lacing bars (ksi)
- $F_u$  = specified minimum tensile strength of fasteners (ksi)
- $A_r$  = cross-sectional area of a fastener (in.<sup>2</sup>)
- $n_r$  = number of fasteners of connecting lacing bar or battens to the main component at one connection
- $m$  = number of panels between point of maximum calculated moment to point of zero moment to either side (as an approximation, the number of panels in half of the main member length ( $L/2$ ) may be used)
- $m_b$  = number of batten planes
- $m_l$  = number of lacing planes
- $M_{p-b}$  = plastic moment of a batten plate about strong axis (kip-in.)
- $P_n^{comp}$  = nominal compressive strength of a lacing bar determined by Article 6.9.4.1 of the *AASHTO BDS* (kip)
- $P_n^{ten}$  = nominal tensile strength of a lacing bar determined by Article 6.8.2 of the *AASHTO BDS* (kip)

**B.2.2 Lacing Bars or Battens in Plane of Flange (Bending about x-x axis in Figure B-1)**

$$I_{x-x} = \sum I_{(x-x)_i} + \sum A_i y_i^2 \quad (\text{B.2.2-1})$$

**B.3 Plastic Section Modulus - Z**

**B.3.1 Lacing Bars or Battens in Plane of Web (Bending about y-y axis in Figure B-1)**

$$Z_{y-y} = \beta_m \sum x_i^* A_i^* \quad (\text{B.3.1-1})$$

where

- $Z_{y-y}$  = plastic section modulus about the y-y axis (in.<sup>3</sup>)
- $x_i^*$  = distance between the center of the gravity of a section  $A_i^*$  and the plastic neutral y-y axis (in.)
- $y_i^*$  = distance between the center of the gravity of a section  $A_i^*$  and the plastic neutral x-x axis (in.)
- $A_i^*$  = cross-sectional area above or below the plastic neutral axis (in.<sup>2</sup>)

**B.3.2 Lacing Bars or Battens in Plane of Flange (Bending about x-x axis in Figure B-1)**

$$Z_{x-x} = \sum y_i^* A_i^* \quad (\text{B.3.2-1})$$

where

- $Z_{x-x}$  = plastic section modulus about the x-x axis (in.<sup>3</sup>)

**B.4 Torsional Constant - J**

$$J = \frac{4(A_{close})^2}{\sum \frac{b_i}{t_i}} \quad (\text{B.4-1})$$

where

- $A_{close}$  = area enclosed within the mean dimension for a box-shaped section (in.<sup>2</sup>)
- $b_i$  = length of the particular segment of a section (in.)
- $t_i$  = average thickness of a segment  $b_i$  (in.)

For determination of torsional constant of a latticed member, the lacing bars or batten plates can be replaced by reduced equivalent thin-walled plates defined as:

$$A_{equiv} = \beta_t A_{equiv}^* \quad (\text{B.4-2})$$

**For laced member (Figure B-1a)**

$$A_{equiv}^* = 3.12 A_d \sin \phi \cos^2 \phi \quad (\text{B.4-3a})$$

**For battened member (Figure B-1b)**

$$A_{equiv}^* = 74.88 \frac{1}{\frac{2ah}{I_b} + \frac{a^2}{I_f}} \quad (\text{B.4-3b})$$

$$t_{equiv} = \frac{A_{equiv}}{h} \tag{B.4-4}$$

where

- $a$  = distance between two battens along the member axis (in.)
- $A_{equiv}$  = cross-sectional area of a thin-walled plate equivalent to lacing bars considering shear transferring capacity (in.<sup>2</sup>)
- $A_{equiv}^*$  = cross-sectional area of a thin-walled plate equivalent to lacing bars or battens assuming full section integrity (in.<sup>2</sup>)
- $t_{equiv}$  = thickness of equivalent thin-walled plate (in.)
- $h$  = depth of a member in the lacing plane (in.)
- $A_d$  = cross-sectional area of all diagonal lacings in one panel (in.<sup>2</sup>)
- $I_b$  = moment of inertia of a batten plate (in.<sup>4</sup>)
- $I_f$  = moment of inertia of one side of solid flange about weak axis (in.<sup>4</sup>)
- $\beta_t$  = reduction factor for the torsion constant

**For laced member (Figure B-1a)**

$$\beta_t = \frac{\cos\phi \times \text{smaller of } \begin{cases} P_n^{comp} + P_n^{ten} \\ n_r A_r (0.6F_u) \end{cases}}{0.6F_{yw} A_{equiv}^*} \leq 1.0 \tag{B.4-5a}$$

**For battened member (Figure B-1b)**

$$\beta_t = \frac{\text{smaller of } \begin{cases} A_b (0.6F_{yw}) h / a \\ 2M_{p-b} / a \\ n_r A_r (0.6F_u) h / a \end{cases}}{0.6F_{yw} A_{equiv}^*} \leq 1.0 \tag{B.4-5b}$$

## APPENDIX C

### YIELD SURFACE EQUATIONS FOR DOUBLY SYMMETRICAL STEEL SECTIONS

This appendix presents the yield surface expressions for typical steel sections suitable for use in an inelastic static analysis.

The general shape of the yield surface for a doubly symmetrical steel section as shown in Figure C-1 can be described approximately by the following general equation (Duan and Chen 1990).

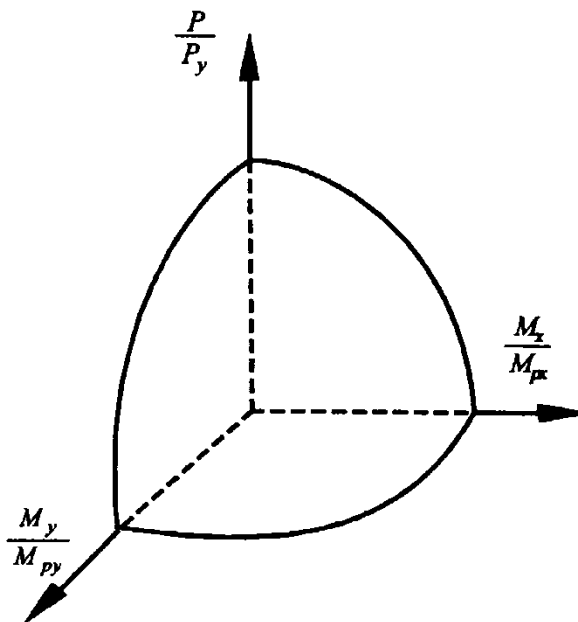

**Figure C-1 Typical Yield Surface for Structural Steel Sections**

$$\left( \frac{M_x}{M_{pcx}} \right)^{\alpha_x} + \left( \frac{M_y}{M_{pcy}} \right)^{\alpha_y} = 1.0 \quad (C-1)$$

where

$M_x, M_y$  = moment about the  $x$ - $x$  and  $y$ - $y$  the principal axes, respectively (kip-in.)

$M_{pcx}, M_{pcy}$  = moment capacities about the  $x$ - $x$  and the  $y$ - $y$  principal axes, respectively, reduced for the presence of axial force (kip-in.); and can be obtained by the following formulas:

$$M_{pcx} = M_{px} \left[ 1 - \left( \frac{P}{P_y} \right)^{\beta_x} \right] \quad (C-2)$$



$$M_{pcy} = M_{py} \left[ 1 - \left( \frac{P}{P_y} \right)^{\beta_y} \right] \tag{C-3}$$

where

- $P$  = axial load (kip)
- $M_{px}, M_{py}$  = plastic moments about the  $x$ - $x$  and the  $y$ - $y$  principal axes, respectively (kip-in.)
- $\alpha_x, \alpha_y,$  = moment interaction parameters about the  $x$ - $x$  and the  $y$ - $y$  principal axes, respectively, as a function of cross section and axial force
- $\beta_x, \beta_y$  = moment-axial force interaction parameters about the  $x$ - $x$  and the  $y$ - $y$  principal axes, respectively, as a function of cross section

Equation (C-1) represents a smooth and convex surface in the three-dimensional stress-resultant space. It meets all special conditions and is easy to implement in a computer-based structural analysis.

**Table C-1 Parameters for Doubly Symmetrical Steel Sections**

Section Types	$\alpha_x$	$\alpha_y$	$\beta_x$	$\beta_y$
Solid rectangular	$1.7 + 1.3 (P/P_y)$	$1.7 + 1.3 (P/P_y)$	2.0	2.0
Solid circular	2.0	2.0	2.1	2.1
I-shape	2.0	$1.2 + 2 (P/P_y)$	1.3	$2 + 1.2 (A_w/A_f)$
Thin-walled box	$1.7 + 1.5 (P/P_y)$	$1.7 + 1.5 (P/P_y)$	$2 - 0.5 \bar{B} \geq 1.3$	$2 - 0.5 \bar{B} \geq 1.3$
Thin-walled circular	2.0	2.0	1.75	1.75

where  $\bar{B}$  is ratio of width to depth of box section with respect to bending axis

Orbison (1982) developed the following equation for a wide-flange section by trial and error and curve fitting:

$$1.15 \left( \frac{P}{P_y} \right)^2 + \left( \frac{M_x}{M_{px}} \right)^2 + \left( \frac{M_y}{M_{py}} \right)^4 + 3.67 \left( \frac{P}{P_y} \right) \left( \frac{M_x}{M_{px}} \right)^2 + 3.0 \left( \frac{P}{P_y} \right)^2 \left( \frac{M_y}{M_{py}} \right)^2 + 4.65 \left( \frac{M_x}{M_{px}} \right)^4 \left( \frac{M_y}{M_{py}} \right)^2 = 1.0 \tag{C-4}$$

## APPENDIX D

### LATERAL STIFFNESS OF STEEL GIRDER BRIDGES IN TRANSVERSE DIRECTION

This appendix presents the approximate lateral stiffness calculation for a steel girder bridge bent in the transverse direction as shown in Figure D-1. The lateral stiffness may be used to estimate the period of the fundamental mode of vibration in the transverse direction.

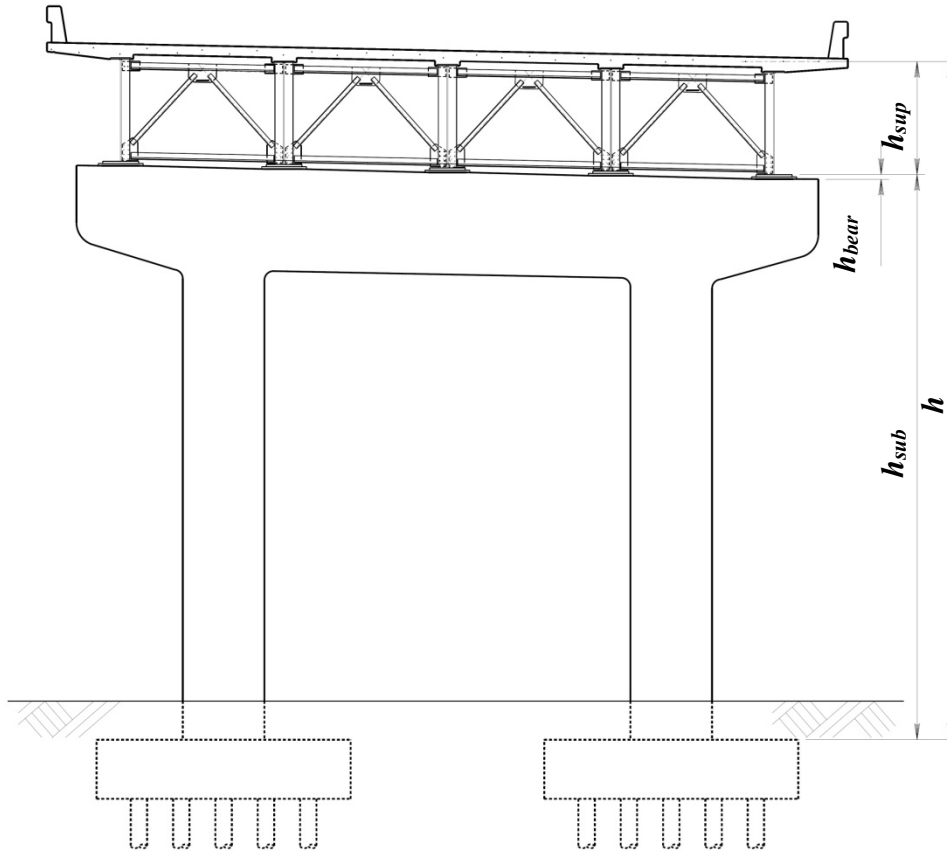

**Figure D-1 A Typical Steel Girder Bridge Bent**

#### D.1 Fundamental Period

The fundamental period,  $T$  in the transverse direction is given by:

$$T = 2\pi \sqrt{\frac{m}{K_{trans}}} \quad (D.1-1)$$

where

- $m$  = sum of the superstructure mass and a half of substructure mass in the tributary length of bridge (kip-sec<sup>2</sup>/in.)
- $K_{trans}$  = lateral stiffness of a bent in the transverse direction (kip/in.)

## D.2 Lateral Stiffness

$$K_{trans} = \frac{1}{\frac{1}{K_{sup}} + \frac{\alpha_{bear}}{K_{bear}} + \frac{\alpha_{sub}}{K_{sub}}} \quad (D.2-1)$$

$$\alpha_{bear} = 1 + \frac{h_{sup}}{h_{bear} + h_{sub}} \quad (D.2-2)$$

$$\alpha_{sub} = \left(1 + \frac{h_{bear}}{h_{sub}}\right) \left(1 + \frac{h_{sup}}{h_{bear} + h_{sub}}\right) \quad (D.2-3)$$

where

$h_{sup}$  = height of the girder superstructure measured from the bottom of the girder flange to center of gravity of the concrete deck (in.)

$h_{bear}$  = height of a bearing (in.)

$h_{sub}$  = height of the substructure (in.)

$h$  = height of a girder bridge =  $h_{sub} + h_{sup} + h_{bear}$  (in.)

$K_{sup}$  = lateral stiffness of the superstructure at a bent (kip/in.)

$K_{sub}$  = lateral stiffness of the substructure at a bent (kip/in.)

$K_{bear}$  = lateral stiffness of bearings at a bent (kip/in.)

$\alpha_{bear}$  = stiffness modification factor of bearings

$\alpha_{sub}$  = stiffness modification factor of the substructure

## D.3 Stiffness of End Cross Frames

$$K_{sup} = \sum K_{endf} + \sum K_{sg} \quad (D.3-1)$$

$$K_{sg} = \frac{\alpha_{fix} E I_{sg}}{h_{sg}^3} \quad (D.3-2)$$

where

$K_{endf}$  = lateral stiffness of an end cross frame/diaphragm (kip/in.)

$K_{sg}$  = lateral stiffness of a steel girder (kip/in.)

$I_{sg}$  = moment of inertia of the effective column section (as specified in Article 6.10.11.2.4b of the *AASHTO BDS*) for a bearing stiffener about the web (in.<sup>4</sup>)

$h_{sg}$  = height of a stiffened steel girder (in.)

$E$  = modulus of elasticity of steel (ksi)

$\alpha_{fix}$  = fixity factor, equal to 12 if full fixity is provided at both flanges of a steel girder; 3 if one end is fully fixed and the other one pinned; and 0 if both ends are pinned.

Engineering judgment is used to determine the level of fixity provided at the ends of girders. It should be noted that the most conservative solution is not obtained when zero fixity is assumed because fixity also adds strength to the diaphragms. The role of the ductile diaphragms is to limit the magnitude of the maximum forces that can be developed in the substructure.

(1) *X or V-Type Cross Frames*

$$K_{endf} = \frac{2EA_b \cos^2 \alpha}{L_b} \tag{D.3-3}$$

where

- $A_b$  = cross-sectional area of a brace (in.<sup>2</sup>)
- $E$  = modulus of elasticity of steel (ksi)
- $L_b$  = length of a brace (in.)
- $\alpha$  = angle between a brace and the horizontal direction

(2) *EBF Cross Frames*

For an EBF as shown in Figure D-2, lateral stiffness is as follows (Zahrai and Bruneau, 1998):

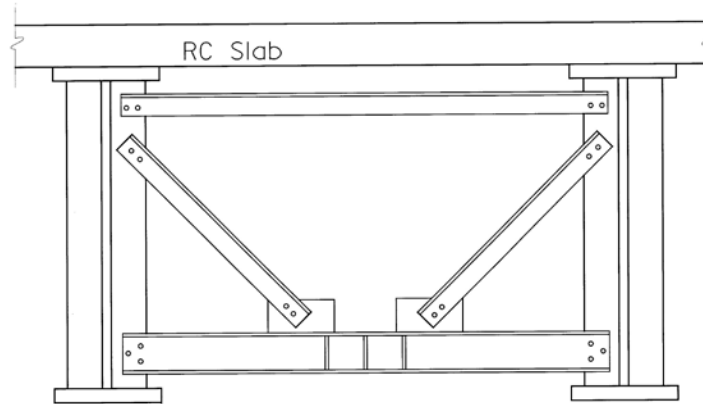

Figure D-2 A Typical EBF Ductile Cross Frame

$$K_{endf} = \frac{E}{\frac{L_b}{2A_b \cos^2 \alpha} + \frac{a}{2A_l} + \frac{e^2 h_{sg}^2}{12L_s I_l} + \frac{1.3e h_{sg}^2}{aL_s A_{s,l}} + \frac{h_{sg} \tan^2 \alpha}{2A_g}} \tag{D.3-4}$$

where

- $L_b$  = length of a brace (in.)
- $L_s$  = girder spacing (in.)
- $a$  = length of the beam outside of a link (in.)
- $e$  = length of a shear link (in.)
- $I_l$  = moment of inertia of a shear link (in.<sup>4</sup>)
- $A_l$  = cross-sectional area of a shear link (in.<sup>2</sup>)
- $A_{s,l}$  = shear area of a shear link (in.<sup>2</sup>)
- $h_{sg}$  = height of a stiffened girder (in.)
- $A_g$  = area of a stiffened girder (in.<sup>2</sup>)

(3) *Single Angle Brace Members*

For single angle brace members,  $A_b$  in Equations (D.3-3) and (D.3-4) shall be replaced by the effective cross section area ( $A_L$ )<sub>eff</sub> specified in Article 3.2.5 to consider bending effects of end connection eccentricities.

## APPENDIX E

### EFFECT OF COMPOUND BUCKLING ON COMPRESSION STRENGTH OF BUILT-UP MEMBERS

This appendix presents the method to consider the effect of compound buckling on compression strength of built-up members.

Two types of built-up members as shown in Figures B-1 and E-1 are commonly used for steel construction. Laced or battened members with widely spaced flange components fall in the first type (Figures B-1), and closely spaced steel shapes interconnected at intervals by welds or connectors form the second type (Figures E-1).

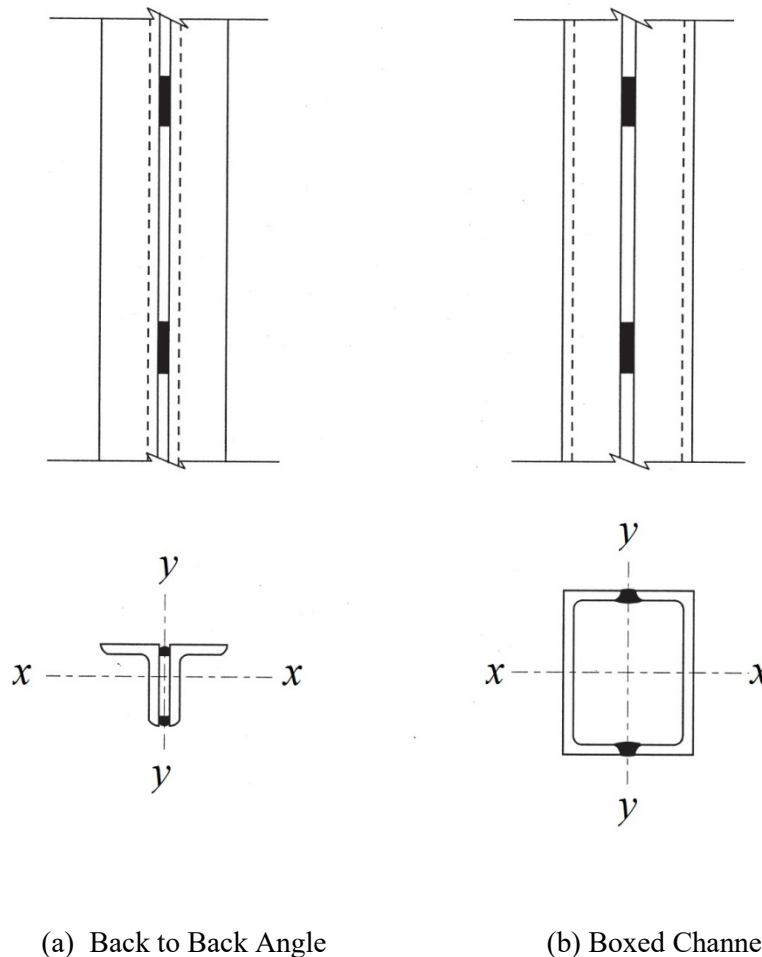

**Figure E-1 Typical Closely-Spaced Built-Up Members**

The compressive strength of both types of members is affected by the shearing effect, and the compound buckling effect (Figure E-2), i.e., interaction between the global buckling mode of the member and the localized component buckling mode between lacing points or intermediate connectors as shown in Figure E-2 (Duan et al., 2002).

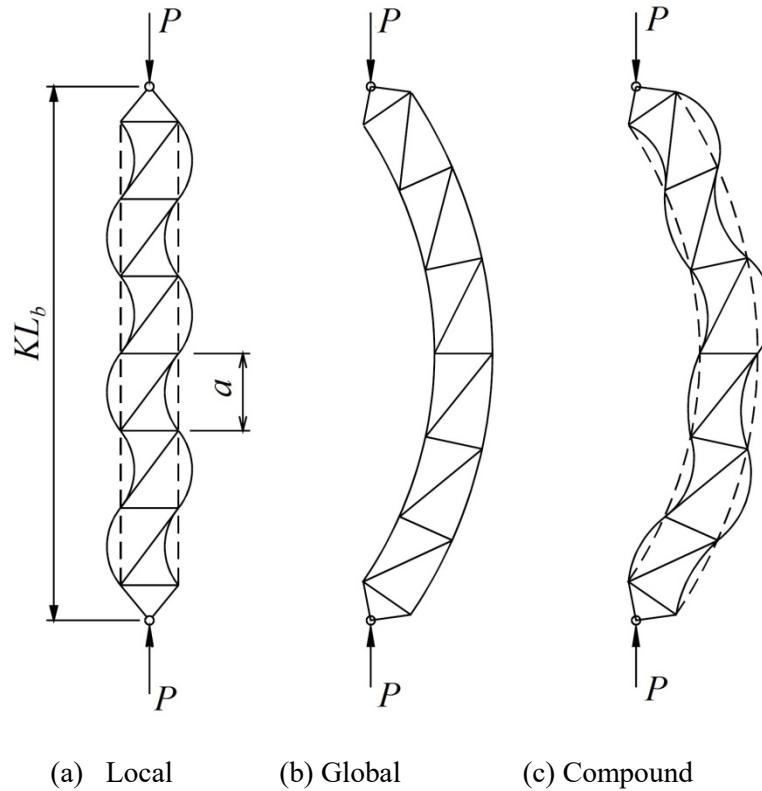

**Figure E-2 Buckling Models of A Built-Up Member**

For the first type, the shearing effect results from the deformation of flanges and laces, while for the second type the effect is caused by the shearing of intermediate connectors. The modified slenderness ratio of built-up members as specified in the *AASHTO BDS* (AASHTO, 2012) and the *AISC Specifications* (AISC, 2010) considers the shearing effect of the second type, but not the first type. For both types of built-up members, limiting the slenderness ratio of each component shape between connection fasteners or welds or between lacing points, as applicable, to 75 percent of the governing global slenderness ratio of the built-up member (AASHTO, 2012; AISC, 2010) effectively mitigates the effect of compound buckling (Duan et al., 2002).

For the purpose of evaluation of an existing structure, when the slenderness ratio of each component shape between the connectors is larger than 75 percent of the governing slenderness ratio of the built-up member as a whole unit, the buckling mode interaction factor,  $\beta$ , is recommended to multiply to the effective length factor of the built-up member (Duan et al., 2002).

$$\beta = \sqrt{\frac{1 + \alpha^2}{1 + \frac{\alpha^2}{1 + \frac{(\delta_o/a)^2 (a/r_f)^2}{2 \left(1 - \frac{(a/r_f)^2}{(\beta KL_b/r)^2}\right)^3}}} } \quad (E-1)$$

where

- $\beta$  = buckling model interaction factor
- $\alpha$  = separation factor =  $h/2r_f$
- $h$  = distance between centroids of individual components perpendicular to the member axis of buckling (in.)
- $r_f$  = radius of gyration of individual flange component relative to its centroidal axis parallel to member axis of buckling =  $\sqrt{I_f / A_f}$  (in.)
- $A_f$  = cross-sectional area of individual flange component (in.<sup>2</sup>)
- $I_f$  = moment of inertia of individual flange component relative to its centroidal axis parallel to member axis of buckling (in.<sup>4</sup>)
- $a$  = length of each laced panel (in.) (See Figure E-3)
- $\delta_o$  = out-of-straightness (in.) (see Figure E-3)
- $K$  = effective length factor of a built-up compression as a whole unit
- $L_b$  = laterally unsupported length of a built-up member in buckling plane (in.)
- $r$  = radius of gyration of built-up section about axis of buckling acting as a whole unit (in.)
- $r_f$  = radius of gyration of individual flange component relative to its centroidal axis parallel to member axis of buckling =  $\sqrt{I_f / A_f}$  (in.)

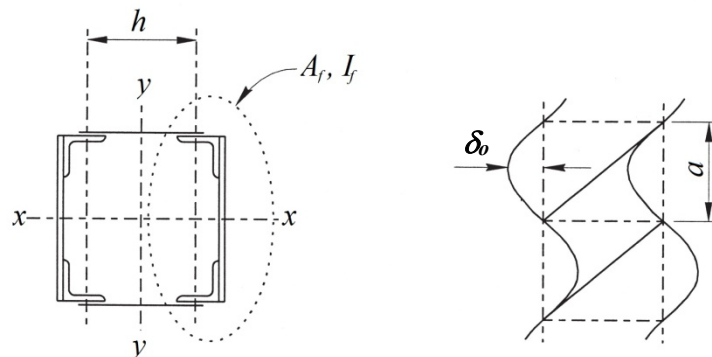

**Figure E-3 Typical Cross Section and Individual Flange Components**

The factor  $\beta$  is a function of four variables: the separation factor ( $\alpha$ ), out-of-straightness ratio, global slenderness ratio ( $KL/r$ ), and local slenderness ratio ( $a/r_f$ ). For  $\alpha > 2$ , the variations of  $\alpha$  have little effect on the  $\beta$  value. Ignoring the local moment of inertia ( $I_f$ ) for a laced member with the widely spaced flange components, Equation (E-1) becomes the following:

$$\beta = \sqrt{1 + \frac{(\delta_o / a)^2 (a / r_f)^2}{2 \left( 1 - \frac{(a / r_f)^2}{(\beta KL_b / r)^2} \right)^3}} \quad (E-2)$$

Figure E-4 provides engineers alternative graphical solutions for widely separated built-up members with  $\alpha > 2$ . In these figures, out-of-straightness ratios ( $\delta_o/a$ ) are 1/500, 1/1000 and 1/1500, and effective slenderness ratios ( $KL_b/r$ ) are 20, 40, 60, 100, 140 and 200. In all these figures, the top line represents  $KL_b/r = 200$ , and the bottom line represents  $KL_b/r = 20$ .

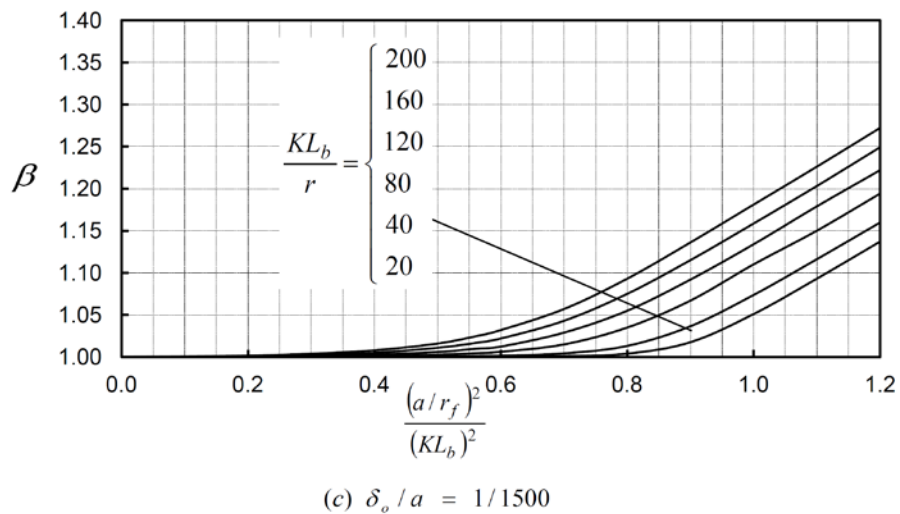
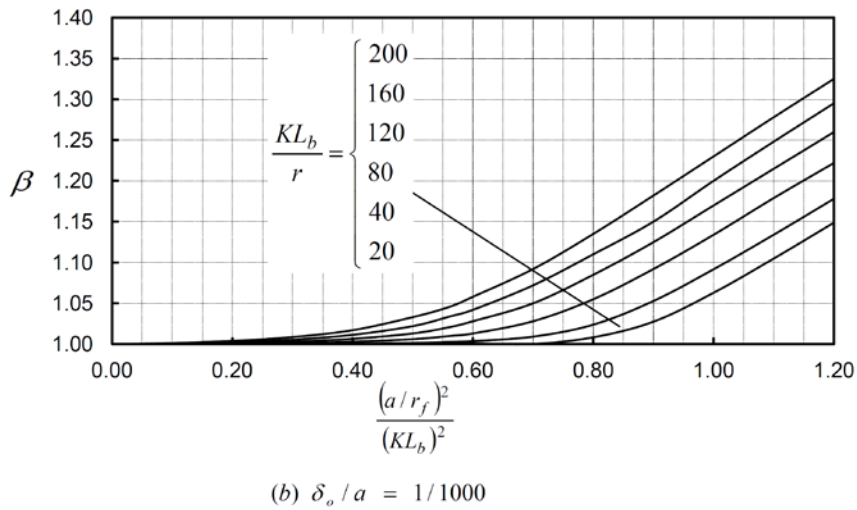
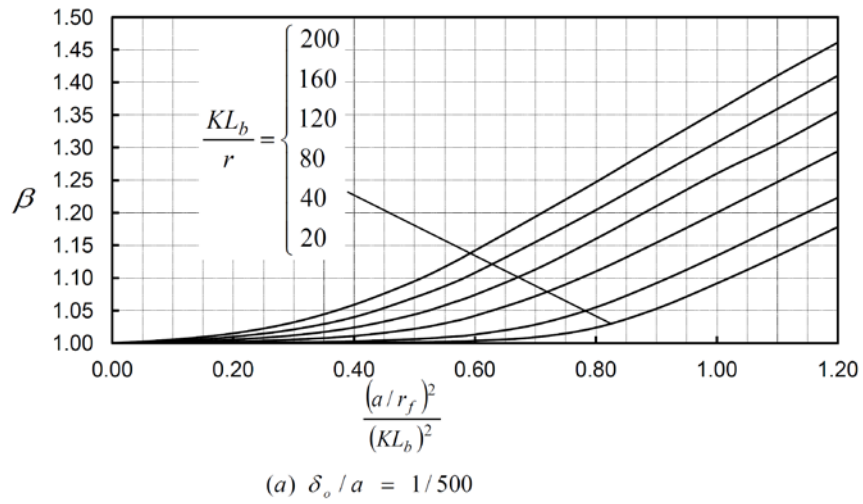

Figure E-4 Buckling Mode Interaction Factor  $\beta$  for  $\alpha > 2$



## APPENDIX F REFERENCES

- AASHTO. (2012). *AASHTO LRFD Bridge Design Specifications*, Customary U.S. Units, 2012, (6<sup>th</sup> Edition), American Association of State Highway and Transportation Officials, Washington, DC.
- AASHTO. (2011). *AASHTO Guide Specifications for LRFD Seismic Bridge Design*, 2<sup>nd</sup> Edition, American Association of State Highway and Transportation Officials, Washington, DC.
- AASHTO. (2014). *Guide Specifications for Seismic Isolation Design*, 4th Edition, American Association of State Highway and Transportation Officials, Washington, DC.
- ACI. (2014). *Building Code Requirements for Structural Concrete (ACI 318-14) and Commentary*, American Concrete Institute, Farmington Hills, MI.
- AISC. (2015). *Seismic Provisions for Structural Steel Buildings*, ANSI/AISC 341-16, Draft Public Review 3, December 18, American Institute of Steel Construction, Chicago, IL.
- AISC. (2014a). *Prequalified Connections for Special and Intermediate Steel Moment Frames for Seismic Applications, Including Supplement No. 1 and Supplement No. 2*, ANSI/AISC 358-10, ANSI/AISC 358s1-11, ANSI/AISC 358s2-14, American Institute of Steel Construction, Chicago, IL.
- AISC. (2014b). *Steel Construction Manual Shapes Database*, V14.1, American Institute of Steel Construction, Chicago, IL. Retrieved October 20, 2014, from <http://www.aisc.org/content.aspx?id=2868>
- AISC. (2014c). *Steel Construction Manual*, 14<sup>th</sup> Edition, American Institute of Steel Construction, Chicago, IL. Retrieved October 20, 2014, from <http://www.aisc.org/content.aspx?id=2868>
- AISC. (2011). *Steel Construction Manual*, 14th Edition, American Institute of Steel Construction, Chicago, IL.
- AISC. (2010a). *Seismic Provisions for Structural Steel Buildings*, ANSI/AISC 341-10, American Institute of Steel Construction, Chicago, IL.
- AISC. (2010b). *Specification for Structural Steel Buildings*, ANSI/AISC 360-10, American Institute of Steel Construction, Chicago, IL.
- AISC. (2010c). *Code of Standard Practice for Steel Building and Bridges*, AISC 303-10, American Institute of Steel Construction, Chicago, IL.
- AISC. (2001). *Manual of Steel Construction, Load and Resistance Factor Design*, 3<sup>rd</sup> Edition, American Institute of Steel Construction, Chicago, IL.
- AISI. (1962). *Light Gage Cold-Formed Steel Design Manual*, American Iron and Steel Institute, Washington, DC.
- Akkari, M. and Duan, L. (2014). “Chapter 5: Nonlinear Analysis,” *Bridge Engineering Handbook: Seismic Design*, 2<sup>nd</sup> Edition, Ed., Chen, W. F. and Duan, L., CRC Press, Boca Raton, FL.
- Alfawakhiri, F. and Bruneau, M. (2001). “Local versus Global Ductility Demands in Simple Bridges,” *J. Struct. Engrg.*, ASCE, 127(5), pp.554-560.
- ASCE. (2010). *Minimum Design Loads for Buildings and Other Structures*, ASCE/SEI 7-10, American Society of Civil Engineers, Reston, VA.
- ASCE. (1971). *Plastic Design in Steel, A Guide and Commentary*, American Society of Civil Engineers, New York, NY.
- ATC. (1996). *Improved Seismic Design Criteria for California Bridges: Provisional Recommendations*, (ATC-32), Applied Technology Council, Redwood City, CA.

- Astaneh, A. A. (2010). "Gusset Plates in Steel Bridges – Design and Evaluation," *Steel Tips*, Structural Steel Education Council (www.steeltips.org), Moraga, CA.
- Astaneh, A. A. (1998). "Seismic Behavior and Design of Gusset Plate," *Steel Tips*, Structural Steel Education Council (www.steeltips.org), Moraga, CA.
- Astaneh, A. A., Goel, S. C., and Hanson, R. D. (1986). "Earthquake-resistant Design of Double Angle Bracings," *Engrg. J.*, AISC, 23(4), 133-147.
- Bahrami, H., Itani, A. M. and Buckle, I. G. (2010). "Guidelines for the Seismic Design of Ductile End Cross Frames in Steel Girder Bridge Superstructures," *Report CCCEE 09-04*, Center for Civil Engineering Earthquake Research, University of Nevada, Reno, NV.
- Berman, J.W. and Bruneau, M., (2013). "Slenderness Limits for Built-up Box Links in AISC 341-10," *Engrg. J.*, AISC, 50(1), 21-32.
- Berman, J. and Bruneau, M. (2008a). "Tubular Links for Eccentrically Braced Frames, I: Finite Element Parametric Study," *J. Struct. Engrg.*, ASCE, 134(5), 692-701.
- Berman, J. and Bruneau, M. (2008b). "Tubular Links for Eccentrically Braced Frames, II: Experimental Verification," *J. Struct. Engrg.*, ASCE, 134(5), 702-712.
- Berman, J. and Bruneau, M. (2007). "Experimental and Analytical Investigation of Tubular Links for Eccentrically Braced Frames," *Engrg. Struct.*, 29(8), 1929-1938.
- Black, C., Makris, N. and Aiken, D. (2004). "Component Testing, Seismic Evaluation and Characterization of Buckling-Restrained Braces," *J. Struct. Engrg.*, ASCE, 130(6), 880-894.
- Bruneau, M. (2013). "Setting Limits," *Modern Steel Construction*, AISC, Feb., 2013, 52-53.
- Bruneau, M., Uang, C. M. and Sabelli R. (2011), *Ductile Design of Steel Structures*, 2<sup>nd</sup> Edition, McGraw-Hill, New York, NY.
- Buckle, I. G., Al-Ani, M. and Monzon, E. V. (2012). "Seismic Isolation Design Examples of Highway Bridges," *NCHRP 20-7 Task 262 (M2)*, Transportation Research Board, Washington, DC.
- Caltrans. (2015). *Standard Specifications 2015*, California Department of Transportation, Sacramento, CA.
- Caltrans (2014a). *California Amendments to the AASHTO LRFD Bridge Design Specifications - Sixth Edition*, California Department of Transportation, Sacramento, CA.
- Caltrans. (2014b). *Bridge Memo to Designers Manual*, California Department of Transportation, Sacramento, CA.
- Caltrans. (2013). *Caltrans Seismic Design Criteria*, Version 1.7, California Department of Transportation, Sacramento, CA.
- Caltrans. (2010). *Memo to Designers 20-1 Seismic Design Methodology*, California Department of Transportation, Sacramento, CA.
- Caltrans (2008). *California Amendments to the AASHTO LRFD Bridge Design Specifications – Fourth Edition*, California Department of Transportation, Sacramento, CA.
- Caltrans. (2001). *Guide Specifications for Seismic Design of Steel Bridges*, 1<sup>st</sup> Edition, California Department of Transportation, Sacramento, CA.
- Caltrans. (1999). *Memo to Designers 20-11 Establishing Bridge Seismic Design Criteria*, California Department of Transportation, Sacramento, CA.

- Caltrans. (1997). *San Francisco-Oakland Bay Bridge West Spans Seismic Retrofit Design Criteria*, Final Draft, California Department of Transportation, Sacramento, CA.
- Carden, L. P., Itani, A. M., and Buckle, I. G. (2006a). "Seismic Performance of Steel Girder Bridges with Ductile Cross Frames using Buckling Restrained Braces," *J. Struct. Engrg.*, ASCE, 132(3), 338-345.
- Carden, L. P., Garcia-Alvarez, A. M., Itani, A. M., and Buckle, I. G. (2006b). "Seismic Performance of Steel Girder Bridges with Ductile Cross Frames using Single Angle X Braces," *J. Struct. Engrg.*, ASCE, 132(3), 329-337.
- Chen, W. F., and Atsuta, T. (1977). *Theory of Beam-Columns*, Vol.1 and 2, McGraw-Hill Inc., New York, NY.
- Chen, W. F. and Han, D. J. (1985). *Tubular Members in Offshore Structures*, Pitman Publishing, Inc., Marshfield, MA.
- Chen, W. F., and Toma, S. (1994). *Advanced Analysis of Steel Frames*, CRC Press, Boca Raton, FL.
- Chopra, A. K. (2011). *Dynamics of Structures*, 4<sup>th</sup> Edition, Prentice Hall, Upper Saddle River, NJ.
- Duan, L. and Chen, W. F. (1990). "A Yield Surface Equation for Doubly Symmetrical Section," *Eng. Struct.*, 12(2), 114-119.
- Duan, L., Le, H. G. and Chen, W. F. (2014). "Chapter 18: Effective Length of Compression Members," *Bridge Engineering Handbook: Fundamentals*, 2<sup>nd</sup> Edition, Ed., Chen, W. F. and Duan, L., CRC Press, Boca Raton, FL.
- Duan, L., Reno, M. and Lynch, J. (2000). "Section Properties for Latticed Members of San Francisco-Oakland Bay Bridge," *J. Bridge Engrg.*, ASCE, 5(2), 156-164.
- Duan, L., Reno, M. and Uang, C. M. (2002). "Effect of Compound Buckling on Compression Strength of Built-up Member," *Engrg. J.*, AISC, 39(1), 30-37.
- Dusicka, P., Itani, A. M. and Buckle, I.G. (2002). "Cyclic Behavior of Shear Links and Tower Assembly of San Francisco-Oakland Bay Bridge Tower," *Report CCCEE 02-06*, Center for Civil Engineering Earthquake Research, University of Nevada, Reno, NV.
- Dusicka, P., Itani, A. M. and Buckle, I. G. (2010). "Cyclic Behavior of Shear Links of Various Grades of Plate Steel," *J. Struct. Engrg.*, ASCE, 136(4), 370-378.
- El-Tayem, A. A. and Goel, S. C. (1986). "Effective Length Factor for the Design of X-bracing Systems," *Eng. J.*, AISC, 23(4), 41-45.
- Fehling, E., Pauli, W. and Bouwkamp, J. G. (1992). "Use of Vertical Shear-Links in Eccentrically Braced Frames," *Proc., 10th World Conf. on Earthquake Engrg.*, Vol.9, Madrid, Spain, July 19-24, 4475-4479.
- Frosch, R. J. (1999). "Shear Transfer between Concrete Elements Using Steel Pipe Connection," *ACI Struct. J.*, 96(6), 1003-1008.
- Goel, S.C. and Lee, S. (1992), "A Fracture Criterion for Concrete-Filled Tubular Bracing Members under Cyclic Loading," *Proceedings of the 1992 ASCE Structures Congress*, ASCE, Reston, VA, 922-925.
- Holzer, S. M., Melosh, R. J., Barker, R. M. and Somers, A. E. (1975). *SINDER: A Computer Code for General Analysis of Two-Dimensional Reinforced Concrete Structures*, Vol. 1. Solution Process, Defense Technical Information Center, Fort Belvoir, VA.
- Imbsen, R. and Wu, L. (2014). "Chapter 12: Seismic Isolation Design for Bridge Structures," *Bridge Engineering Handbook: Seismic Design*, 2<sup>nd</sup> Edition, Ed. Chen, W. F. and Duan, L., CRC Press, Boca Raton, FL.

- Itani, A. M. (1997). "Cyclic Behavior of Richmond-San Rafael Tower Links," *Report No. CCEER 99-4*, Center for Civil Engineering Earthquake Research, University of Nevada, Reno, NV.
- Itani, A. M. and Sedarat, H. (2000). "Seismic Analysis and Design of the AISI LRFD Design Examples of Steel Highway Bridges," *Report No. CEER 00-8*, Center for Civil Engineering Earthquake Research, University of Nevada, Reno, NV.
- Itani, A. M., Vesco, T. D. and Dietrich, A.M. (1998). "Cyclic Behavior of As-Built Laced Members with End Gusset Plates on the San Francisco-Oakland Bay Bridge," *Report No. CCEER 98-01*, Center for Civil Engineering Earthquake Research, University of Nevada, Reno, NV.
- King, W. S., White, D. W. and Chen, W. F. (1992). "Second-Order Inelastic Analysis Methods for Steel-Frame Design," *J. Struct. Engrg.*, ASCE, 118(2), 408-428.
- Lanning, J. and Uang, C. M. (2014) *Guidelines for Using Buckling-Restrained Braces on Bridges for Caltrans Guide Specifications for Seismic Design of Steel Bridges*, Department of Structural Engineering, University of California, San Diego, La Jolla, CA.
- Lanning, J., Benzoni, G. and Uang, C. M. (2013) "The Feasibility of Using Buckling-Restrained Braces for Long-Span Bridges: Near-Fault Protocols and Full-Scale Testing," *Report No. SSRP 13/17*. Department of Structural Engineering, University of California, San Diego, La Jolla, CA.
- Lanning, J., Uang, C. M. and Benzoni, G. (2011). "The Feasibility of Using Buckling-Restrained Braces for Long-Span Bridges: A Case Study," *Report No. SSPR-11/09*, Department of Structural Engineering, University of California, San Diego, La Jolla, CA.
- Levy, R., Joseph, F. and Spillers, W. R. (1997). "Member Stiffness with Offset Hinges," *J. Struct. Engrg.*, ASCE, 123(4), 527-529.
- McDaniel, C. C., Uang, C. M. and Seible, F. (2003). "Cyclic Testing of Built-Up Steel Shear Links for the New Bay Bridge," *J. Struct. Engrg.*, ASCE, 129(6), 801-809
- McDaniel, C. C., Uang, C. M. and Seible, F. (2002). "Cyclic Testing of Suspension Tower Shear Links of the San Francisco-Oakland Bay Bridge," *Report No. SSRP-2001/14*, Department of Structural Engineering, University of California, San Diego, La Jolla, CA.
- Monzon, E. V., Itani, A. M. and Grubb, M. A. (2014). "Nonlinear Evaluation of the Proposed Seismic Design Procedure for Steel Bridges with Ductile End Cross Frames," *Report No. CCEER-14-04*, Center for Civil Engineering Earthquake Research, University of Nevada, Reno, NV.
- Nader, M. and Maroney, B. (2007). "One-of-a-kind Design: The San Francisco-Oakland Bay Bridge Eastern Span," *Struct. Mag.*, Oct., 26-33.
- Nakashima, M. (1995). "Strain-Hardening Behavior of Shear Panels Made of Low-Yield Steel. I: Test," *J. Struct. Engrg.*, ASCE, 121(12), 1742-1749.
- Neal, B. G. (1961). "The Effect of Shear and Normal Forces on the Fully Plastic Moment of a Beam of Rectangular Cross Section," *J. Appl. Mech.*, ASME, 28(2), 269-274.
- Ocel, J. M. (2013). "Guidelines for the Load and Resistance Factor Design and Rating of Riveted and Bolted Gusset-Plate Connections for Steel Bridges," *NCHRP Web-Only Document 197*, Transportation Research Board, Washington, DC.
- Orbison, J. G. (1982). *Nonlinear Static Analysis of Three-dimensional Steel Frames*, Department of Structural Engineering, Cornell University, NY.
- Patty, J., Seible F. and Uang, C. M. (2001). "Seismic Response of Integral Bridge Connections", *Report No. SSRP – 2000/16*, Department of Structural Engineering, University of California, San Diego, La Jolla, CA.

- PCI. (2010). *PCI Design Handbook – Precast and Prestressed Concrete*, 7<sup>th</sup> Edition, Precast/Prestressed Concrete Institute, Chicago, IL.
- Picard, A. and Beaulieu, D. (1987). “Design of Diagonal Cross Bracings Part 1: Theoretical Study,” *Eng. J.*, AISC, 24(3), 122-126.
- Picard, A. and Beaulieu, D. (1988). “Design of Diagonal Cross Bracings Part 2: Experimental Study,” *Eng. J.*, AISC, 25(4), 156-160.
- Popov, E. P. and Tsai, K. C. (1989). “Performance of Large Seismic Steel Moment Connections under Cyclic Loads,” *Engrg. J.*, AISC, 26(2), 51-60.
- Reno, M. and Pohll, M. N. (2013). “Incorporating Buckling Restrained Braces (BRB) as Part of the Auburn-Forest Hill Bridge Seismic Retrofit,” *The 29th US - Japan Bridge Engineering Workshop*, Nov. 11-13, Tsukuba, Japan
- Sabelli, R., Mahin, S. and Chang, C. (2003). “Seismic Demands on Steel Braced Frame Buildings with Buckling-Restrained Braces” *Engrg. Struct.*, 25(5), 655-666.
- Tang, X. and Goel, S.C. (1989), “Brace Fractures and Analysis of Phase I Structure,” *J. Struct. Engrg.*, ASCE, 115(8), 1960–1976.
- Tao, J. R. and Treyger, S. (2014). “Chapter 11: Seismic Design of Cable-Supported Bridges,” *Bridge Engineering Handbook: Seismic Design*, 2<sup>nd</sup> Edition, Ed., Chen, W. F. and Duan, L., CRC Press, Boca Raton, FL.
- Tremblay, R. (2000), “Influence of Brace Slenderness on the Seismic Response of Concentrically Braced Steel Frames,” *Behaviour of Steel Structures in Seismic Areas—Stessa 2000: Proceedings of the Third International Conference*, Montreal, Canada, August 21-24, 2000, F.M. Mazzolani and, R. Tremblay, eds., 527–534.
- Tsai, K.C., Hsiao, P. C., Wang, K. J., Weng, Y. T., Lin, M. L., Lin, K. C., Chen, C. H., Lai, J. W. and Lin, S. L. (2008). “Pseudo-Dynamic Tests of a Full-Scale CFT/BRB Frame-Part I: Specimen Design, Experiment and Analysis,” *Earthquake Eng. & Struct. Dyn.*, 37(7), 1081-1098.
- Uang, C. M., Tsai, K. C. and Bruneau M. (2014). “Chapter 9: Seismic Design of Steel Bridges,” *Bridge Engineering Handbook: Seismic Design*, 2<sup>nd</sup> Edition, Ed., Chen, W. F. and Duan, L., CRC Press, Boca Raton, FL.
- Uang, C. M., Nakashima, M. and Tsai, K. C. (2004). “Research and Application of Buckling Restrained Braced Frames,” *Steel Struct.*, 4, 301-313
- Usami, T., Lu, Z. and Ge, H. (2005). “A Seismic Updating Method for Steel Arch Bridges using Buckling-Restrained Braces,” *Earthquake Eng. Struct. Dyn.* 34(4-5), 471-496.
- Usami, T., Ge, H. and Luo, X. Q. (2009). “Experimental and Analytical Study on High-Performance Buckling Restrained Dampers for Bridge Engineering,” *Proceedings of the 3<sup>rd</sup> International Conference on Advance in Experimental Structural Engineering*, Oct. 15-16, San Francisco, CA,
- Vincent, J. (1996). “Seismic Retrofit of the Richmond-San Rafael Bridge,” *Seismic Design, Evaluation, and Retrofit of Steel Bridges, Proceedings of the Second U.S. Seminar*, Ed. Astaneh-Asl, A. and Roberts, J., November 20-21, 217-234
- Wang, W. H. (2013). “A Study of Stiffness of Steel Bridge Cross Frames,” *Ph.D. Dissertation*, University of Texas at Austin, Austin, TX.
- Wassef, W. G., Davis, D. and Sritharan, S., et al. (2004). “Integral Steel Box-Beam Pier Caps,” *NCHRP Report 527*, Transportation Research Board, Washington, DC.

- Wei, X. and Bruneau, M., (2013). “Resilient Bridges: Replaceable Structural Fuses for Post-Earthquake Accelerated Service, Phase I: Analytical Investigation,” *Technical Report CA13-2296*, California Department of Transportation, Sacramento, CA.
- Wei, X. and Bruneau, M. (2015). “Bidirectional-Ductile End Diaphragms for Seismic Performance and Substructure Protection,” *NCHRP IDEA 172 Final Report*, November 1, University at Buffalo, Buffalo, NY.
- Whitmore, R. E. (1952). “Experimental Investigation of Stresses in Gusset Plates,” *Bulletin 16*, University of Tennessee, Knoxville, TN.
- Zaghi, A. E. and Saiidi, M. (2010). “Seismic Design of Pipe-Pin Connections in Concrete Bridges,” *Report No. CCEER-10-01*, Center for Civil Engineering Earthquake Research, University of Nevada, Reno, NV.
- Zahrai, S. M. and Bruneau, M. (1998). “Impact of Diaphragms on Seismic Responses of Straight Slab-on-Girder Steel Bridges,” *J. Struct. Engrg.*, ASCE, 124(8), 938-947.
- Zahrai, S. M., and Bruneau, M. (1999a). “Ductile End-Diaphragms for the Seismic Retrofit of Slab-on-Girder Steel Bridges”, *J. Struct. Engrg.*, ASCE, 125(1), 71-80.
- Zahrai, S. M. and Bruneau, M. (1999b). “Cyclic Testing of Ductile End-Diaphragms for Slab-on-Girder Steel Bridges,” *J. Struct. Engrg.*, ASCE, 125(9), 987-996.



This page is intentionally left blank.