

## 12-4 CRITERIA FOR CONTROL DIMENSION “Y” ON STEEL GIRDERS

The control dimension “Y” is defined as the distance from the top of the deck slab to the top of web plate at the support bearings and should be shown on the “Typical Section” sheet. In multiple span structures, control dimension “Y” should be constant if possible. Proper embedment of shear connectors on composite girders may require special attention. Straight girders on a horizontal curve bridge with a cross slope also require special consideration.

The control dimension “Y” includes the following components:

- (1) Deck thickness
- (2) Correction for roadway slope =  $\frac{\text{Maximum Flange Width}}{2} \times (\text{roadway cross slope})$
- (3) Maximum top flange thickness
- (4) Correction for sagging (for the straight girder on a sharp horizontal curve or at a sag vertical curve, the depth of fillet at the supports shall be increased so that the deflected girder will not appear to be sagging).
- (5) Excess fillet to allow for fabricating tolerance in girder camber; Allow 25 mm (1 in.) for span lengths less than or equal to 12.2 m (40 ft.). Allow 38 mm (1.5 in.) for span lengths greater than 12.2 m (40 ft.)

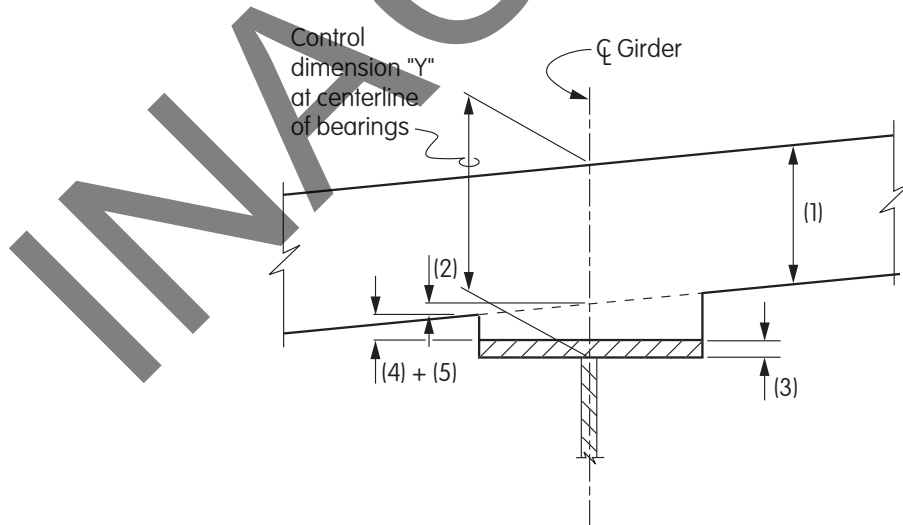

*original signed by Richard D. Land*

Richard D. Land  
Deputy Chief, Division of Engineering Services,  
Structure Design