



Trenchless Construction

Trenchless construction consists of installing culverts or utility conduit via “tunneling” under a highway. Trenchless construction should be considered in areas where conventional open-trench construction methods are undesirable (e.g., traffic impacts).

The role of the Geoprofessional (GP) for trenchless projects is to:

- Perform a geotechnical investigation
- Evaluate geotechnical conditions for suitability of trenchless construction
- Produce a Geotechnical Design Report (GDR)
- Provide design and contract preparation support
- Provide construction support

The role of the Contractor is:

- Selection of construction methods and equipment feasible for the work.
- Estimation of potential pavement settlement profile.
- Evaluation of potential damage to existing facilities.
- Implementation of preventive and/or mitigation measures.
- Monitoring of pavement settlement and the impacts of construction to facilities.

Investigation

The purpose of geotechnical investigation for trenchless construction is to provide sufficient information to facilitate selection of an appropriate construction method by the Contractor and reduce uncertainties and risks during construction. The subsurface information is conveyed through the GDR, which includes Boring Records. During geotechnical investigation, be alert for the presence of following subsurface conditions which may affect the selection of trenchless construction method and execution:

- Cobbles, boulders, loose sand, soft clay
- Rock, its hardness, strength, and fracturing
- Groundwater

If the literature search and/or site visit produces sufficient geologic information, then required borings may be eliminated.

If the geotechnical investigation reveals information that indicates the use of trenchless construction methods may be problematic, less practical, or more expensive, notify and discuss with the client.

Perform at least one boring at each location. For culverts with inside diameters equal to or greater than 30 inches, perform at least two exploratory borings with one boring near each end. For installations that traverse a divided highway, perform an additional boring



in the median. Eliminate borings when geologic and subsurface conditions are known and/or as-built boring data are available.

Extend the boreholes at least 10 feet below the invert of the culvert or utility conduit, and to a stiff or dense soil layer. In the zone between one diameter above the crown and one diameter below the invert of the culvert, retrieve soil specimens using continuous sampling. Corrosivity must be evaluated.

When a project has multiple culverts along a highway alignment perform borings in an order such that interpolation can be used to potentially eliminate borings to reduce exploration time and costs. This approach is best used in areas of consistent geology. If the geologic evaluation can be confidently assessed, then it is acceptable to eliminate borings at some culvert locations.

When scheduling subsurface exploration for culverts with diameters equal to or greater than 30 inches, collaborate and coordinate with District Environmental Analysis, so that District Environmental Analysis may perform soil vapor profiling during drilling. The data obtained from soil vapor profiling may be included in the construction submittals to Cal OSHA Mining and Tunneling Unit. The data may assist Cal OSHA in classifying the excavation.

Feasibility Study

Do not perform geotechnical design or analysis for Caltrans trenchless construction projects. The geotechnical analyses and design, such as estimated ground surface settlement profile, depend on the construction method and equipment used, and is the contractor's responsibility.

Advise and discuss with the client if the findings from geotechnical investigation indicated the use of trenchless construction methods can be problematic, less practical, or more expensive, and the option of open trench should be considered instead.

The scenarios that favor open trench construction include:

- Installation in highway with low traffic volume
- Shallow installation
- Difficult subsurface conditions (see Investigations section)
- No room for setting up trenchless construction equipment

Open trench construction will require traffic management, such as a super-closure, one-way traffic control, staged construction, and/or traffic diversion.

An overview and general applicability of commonly used trenchless construction methods based on soil and rock conditions and SPT N values are shown in the following tables. These tables are included in the second and third references listed above.

Table 1 – Overview of Commonly Used Trenchless Construction Methods
(From Iseley and Gokhale (1997))

Method	Diameter (in)	Primary Application
Jack and bore	8 – 60	in Crossings
Microtunneling	10 – 120	in Sewer installations
Horizontal directional drilling	2 – 48	in Pressure lines, water, gas, cable
Pipe jacking	42 – 120	in Sewers, pressure lines, crossings

Table 2 – Applicability of Commonly Used Trenchless Construction Methods to Various Soil and Rock Conditions
(From Iseley et al. (1999))

Soil Conditions	Jack and Bore (Auger Boring)	Microtunneling	Horizontal Directional Drilling	Pipe Jacking
Soft to very soft clays, silts, and organic deposits	Y	Y	Y	M
Medium to very stiff clays and silts	Y	Y	Y	Y
Hard clays and highly weathered shales	Y	Y	Y	Y
Very loose to loose sands above groundwater table	M	Y	Y	M
Medium to dense sands below groundwater table	N	Y	Y	N
Medium to dense sands above groundwater table	Y	Y	Y	Y
Gravel and cobbles < 2" – 4"	Y	Y	M	Y
Cobbles, boulders, and obstructions > 4" – 6"	M	M	M	M
Weathered rocks, marls, chalks, and cemented soils	Y	Y	Y	M
Slightly weathered to intact rock	Y	M	M	N

Y = generally used; M = possible but difficulties may occur; N = generally unsuitable.

Table 3 – Applicability of Commonly Used Trenchless Construction Methods to Soil and Rock Types
(From Iseley et al. (1999))

Soil Type	SPT N Value	Jack and Bore (Auger Boring)	Microtunneling	Horizontal Directional Drilling	Pipe Jacking
Cohesive soils (clay)	N < 5 (Soft)	M	Y	M	M
	N = 5-15 (Firm)	Y	Y	Y	Y
	N > 15 (Stiff – Hard)	Y	Y	Y	Y
Cohesionless soils (sand/silt)	N < 10 (Loose)	M	Y	M	M
	N = 10-30 (Medium)	Y	Y	Y	Y
	N > 30 (Dense)	Y	Y	Y	Y
	High groundwater	N	Y	M	M
Boulders/cobbles		< 33% D	< 33% D	M	M
Full-face rock		< 12 ksi	< 30 ksi	< 15 ksi	< 30 ksi

Y = recommended; M = possible but difficulties may occur; N = generally unsuitable;
D = size of largest cobble/boulder versus minimum casing diameter.

Reporting

Trenchless construction information should be included in the Geotechnical Design Report and include the following.

Geotechnical Conditions

For culverts of 30 inches or greater in diameter, in addition to the required information in this section, provide a summary of the information obtained from geotechnical investigation that address Cal OSHA requirements as described below so that the District can compile and submit the required information.

According to Cal OSHA Mining and Tunneling Unit [Underground Classification Requirements](#), “for all tunnels, ... all pipejacking, and boring projects 30 inches or greater in diameter must be Classified by the Mining and Tunneling Unit before bidding.” For Cal OSHA to classify the excavation, the submittal of following information, among others, is required:



“One copy of any geological information and/or soils reports that are proximate to, or representative of, the conditions existing at the site of the underground construction work, especially as they relate to the presence of flammable gases and hydrocarbons.”

Recommendations

It is the responsibility of the Contractor to determine and select construction means and methods for the project and site. It is also the responsibility of the Contractor to evaluate possible damage to facilities, such as pavement settlement, implement preventive and mitigation measures, and monitor impacts to facilities during construction. Therefore, do not provide design recommendations relating to construction methods.

The Recommendations section of the geotechnical report may be omitted or left blank for most projects.

PS&E Package Development

Work with the Districts to:

- Verify that the project Special Provisions have incorporated the [Trenchless Construction nSSP](#) posted on the Geotechnical Services website.
- Coordinate with the Districts and the owner of the Trenchless Construction nSSP for any revisions needed from the Districts. The nSSP has relaxed monitoring requirements for rural highways. However, if the repair of highway pavement damaged by trenchless construction may be performed cheaply, and lane closure needed for the repair is not a major issue, the district may opt to further reduce or remove movement monitoring requirements to save construction cost. To do so, the annual average daily traffic criteria can be adjusted to switch off monitoring requirements in the nSSP, instead of removing the contract clauses, which can be messy and left with different versions of nSSPs throughout the years.

Geotechnical Tasks during Construction

Coordinate with the Resident Engineer and request for review of the following submittals according to project Special Provisions:

- Shop drawings
- Daily construction records
- Post-construction records

Attend the Pre-Construction Meeting and discuss:

- Shop drawings and the proposed construction method
- Mitigation plans for both during and after construction

If requested by the Resident Engineer, provide technical support.



References

Review these documents before developing projects that include trenchless methods for culvert installation.

- *Standard Design and Construction Guidelines for Microtunneling*, ASCE/CI 36-15, ISBN 978-0-7844-7857-8, 2015
- [*Synthesis of Trenchless Technologies*](#), Virginia Center for Transportation Innovation and Research, VCTIR 15-R16, June 2015
- [*Trenchless Installation of Conduits Beneath Roadways*](#), NCHRP Synthesis of Highway Practice 242, 1997
- [*Trenchless Methods for Storm Drain Culvert Renewal/Replacement*](#), Caltrans, May 2018
- *Encroachment Permit Manual, Chapter 600 – Utility Permits, 603.6A Trenchless Technologies*, Caltrans
- *Iseley, T., Najafi, M., and Tanwani, R. Trenchless Construction Methods and Soil Compatibility Manual. 3rd ed.* The National Utility Contractors Association, Arlington, VA, 1999.



Commonly used Trenchless Methods

The following list presents commonly used trenchless methods and brief descriptions of each method:

- Horizontal Directional Drilling
- Microtunneling
- Pipe Jacking
- Pipe Jacking / Open Shield Pipe Jacking
- Earth Pressure Balance Machine (EPBM) Pipe Jacking
- Pipe Ramming
- Guided Pipe Ramming
- Pilot Tube Method
- Auger Boring
- Guided Boring
- Intermediate Jacking Station
- Hand Tunneling

Horizontal Directional Drilling

Horizontal Directional Drilling (HDD), also known as directional boring, is a method of installing pipes underground using a steerable arc-drilling rig. The bore path can be monitored and adjusted according to the location of the proposed utility or obstacles that are encountered. HDD is a three-phase process:

1. Pilot hole: A drill bit tool creates a pilot hole approximately 1 to 5 in in diameter from the entry to the receiving locations at an angle of 5 to 30 degrees from the ground surface.
2. Reaming: Enlarging the hole by approximately 50% and prepares it for the pipe placement. A reamer tool replaces the drill bit and is pulled back or pushed forward by the HDD machinery to expand the pilot hole. Multiple passes with the reamer may occur during construction.
3. Pipe pullback: The product pipe is attached to the reamer and pulled through the HDD borehole into place.

Drilling fluid is used to suspend and remove soil cuttings. It is also used to stabilize the hole, reduce friction, cool and lubricate the drill bit, and control soil pressures below the surface. Typically, drilling fluid consists of a mixture of water, bentonite, soda ash, and chemicals that assist in preventing swelling. The slurries most used are bentonite-based.

- Accuracy: Varies pending on operator skills
- Pipe: 2- to 48-inch diameter (OD); Steel, HDPE, PVC, Clay, and fiber glass pipe (FRP)
- Typical length: < 6,000 feet
- Unsuitable: Soil containing more than 50% gravel or loose soil, and rock sizes more than 3 inch in diameter

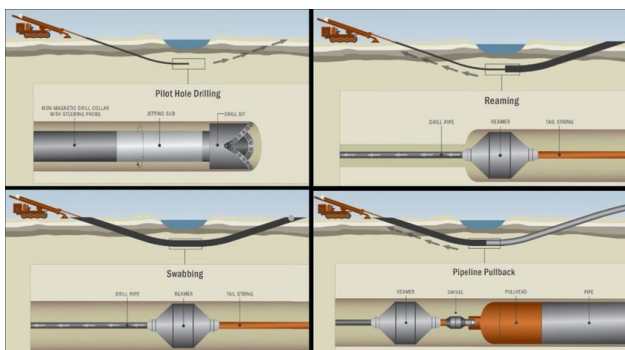

Microtunneling

Microtunneling requires significant ground excavation to construct launching and receiving shafts at the entry and exit points. It requires hydraulic jacking system, closed-loop slurry system, slurry separation unit to remove the soil from the slurry mixture, lubrication system to lubricate the exterior of the pipe string, laser guidance system, crane to hoist pipe sections into the jacking shaft, and control room. Microtunneling Boring Machine (MTBM) is advanced by overcutting the soil by 0.5 in.

- Accuracy: ± 2 inches
- Pipe: 24- to 102-inch diameter (OD); Steel, RCP, VCP, HOBAS®
- Typical length: < 1,500 feet
- Unsuitable: Running/flowing groundwater, very loose sand, very soft and soft clay/silt, boulder, hard rock, mixed face condition



Pipe Jacking

Pipe jacking is a trenchless method for installing a pipe through the ground from a drive shaft to a reception shaft. The pipe is propelled by jacks located in the drive shaft. The jacking force is transmitted through the pipe to the face of the pipe jacking excavation.

- Accuracy: ± 2 inches
- Pipe: 42- to 132-inch diameter (OD); Steel, RCP, fiber glass pipes with high accuracy
- Typical length: < 1000 feet
- Unsuitable: Groundwater table above the invert, loose sandy soils below the groundwater table, cobbles, boulders
- Construction: Manual or mechanical soil excavation; Intermediate jacking stations for long pipelines



Pipe Jacking/Open Shield Pipe Jacking

Referred to as “jack and bore”, pipejacking is a system for directly installing pipes behind a shield, with or without a powered excavation head by hydraulic jacking from a launch shaft such that the pipes form a continuous string in the ground. The installation process requires a jacking frame and thrust block in the launch shaft to provide forward thrust. Installation involves a cyclic process of loading the pipe onto the cradle behind the shield, jacking the pipe forward into the ground while simultaneously excavating the soil, retracting the jacks, and repeating the process until the shield reaches the reception shaft.

- Accuracy: ± 2 inches
- Pipe: 48- to 168-inch diameter (OD); Steel, RCP, VCP, HOBAS
- Typical length: < 1,000 feet
- Unsuitable: Groundwater table above the invert, loose/soft soils below the groundwater table



Earth Pressure Balance Machine Pipe Jacking

Earth Pressure Balance Machine (EPBM) Pipe Jacking is a person-controlled, guided, pipe jacking method that provides continuous face support. The method is similar to Microtunneling, but for larger diameter pipes. EPBM pipejacking uses mechanical pressure applied to the face to counterbalance the earth and groundwater pressures. Spoil is mixed with soil conditioners which prevent sticking of clays to the machinery and reduce groundwater inflows. The conditioned soil is transported from the face by a tightly fitting auger system to muck carts which transport the spoils to the jacking shaft for removal.

- Accuracy: ± 1 to 2 inches
- Pipe: 54- to 144-inch diameter (OD); Steel, RCCP, RCP, HOBAS
- Typical length: < 1,000 ft
- Unsuitable: Groundwater table above the invert; sand, gravel, cobbles, boulders below the groundwater table

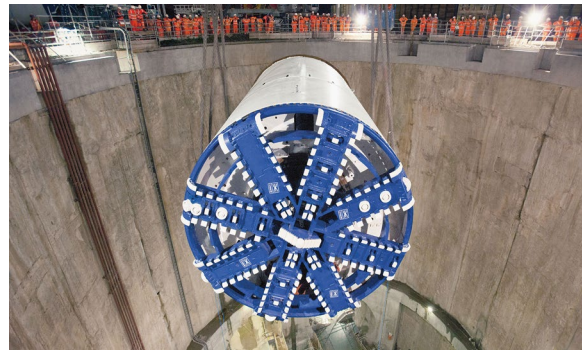
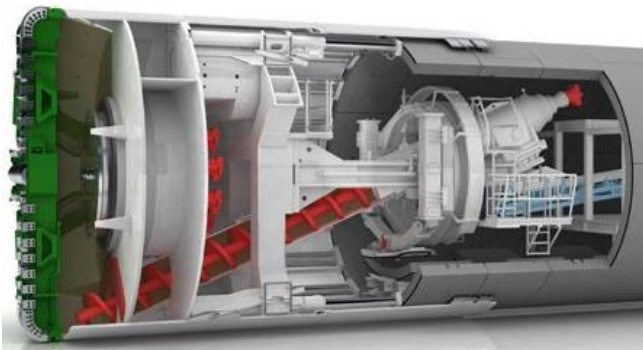

Pipe Ramming

Pipe ramming is a non-steerable installation method for driving an open-ended steel casing using a pneumatic hammer. Because of the energy involved with each blow, a mandrel must precede the driven pipe. Like the jacking process, the hammering process requires the removal of displaced soil and material as the pipe moves into the embankment.

- Accuracy: ± 24 to 60 inches
- Pipe: 8- to 144-inch diameter (OD); Steel
- Typical length: < 300 feet
- Unsuitable: Groundwater table above the invert; rock/dense sand below the groundwater table, boulders
- Construction: Low settlement/heave risk; Noisy due to pipe ramming

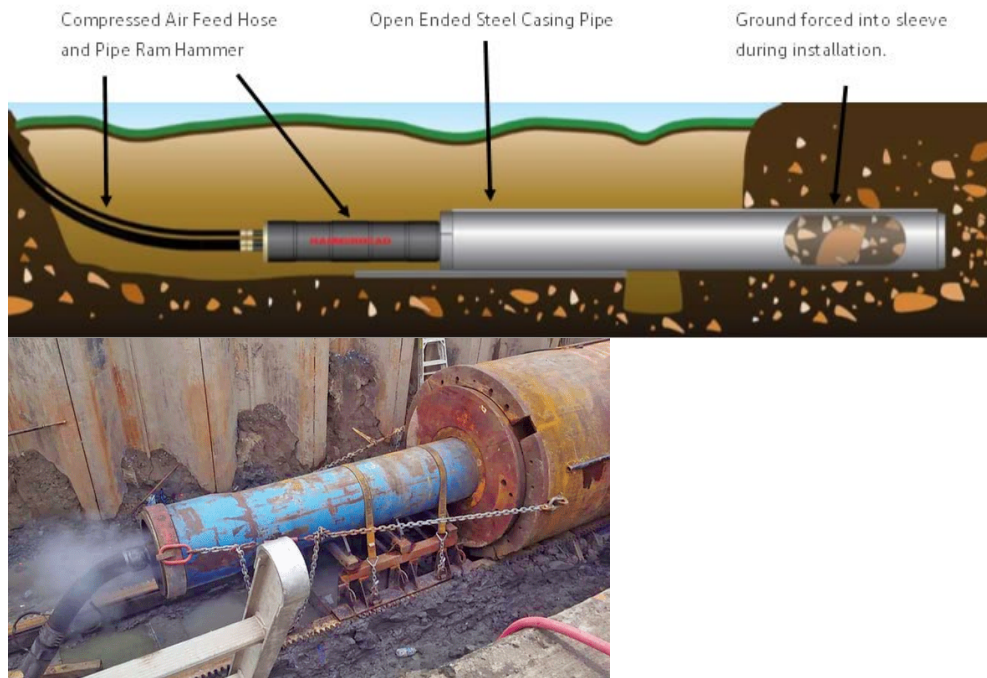



Guided Pipe Ramming

Guided pipe ramming is a hybrid trenchless technique which can increase the achievable accuracy of the pipe ramming method. The hybrid involves the use of the pilot tube method, pipe ramming, and sometimes auger boring. The following are the processes for Guided Pipe Ramming:

- Installation of a pilot bore by a pilot tube machine from launch area to exit side
 - Removal of the guidance head
 - Special adapter attached to pilot tubes & hammer, driving the pipes
-
- Accuracy: ± 0.5 inches over 300 feet
 - Pipe: 8- to 144-inch diameter (OD); Steel
 - Typical length: < 300 feet
 - Unsuitable: Groundwater table above the invert; rock/dense sand below the groundwater table, cobbles, boulders
 - Construction: Better accuracy than pipe ramming; Pilot tube left in ground

Pilot Tube Method

A two/three stage process for accurately installing pipes by use of a guided pilot tube, followed by upsizing to install the product pipe. After the jacking/reception shafts are in place, the machine is set in place (desired grade, height, alignment). The pilot tube is guided by camera mounted theodolite and monitor. The pilot bore slanted face displaces the soil, not excavating, thus advancing to the desired location. The pilot bore is enlarged by auger casings which remove the excavated soil in Jacking shaft, and pilot tube is removed from reception shaft. Finally, the product pipe is jacked into place while auger casings are removed from the reception shaft.

- Accuracy: ± 0.5 inches
- Pipe: 4- to 48-inch diameter (OD); Steel, RCP, HOBAS®, Vitrified Clay pipe
- Typical length: < 400 feet
- Unsuitable: Groundwater table above the invert, very dense sand, cobbles, boulders

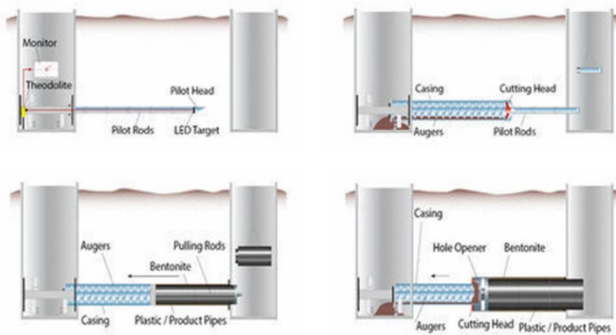

Auger Boring

Technique to form a cased bore from a drive pit to a reception pit. Auger boring rig in the drive pit with its rotating head excavating soil. Spoil is removed back to the drive shaft. After each casing section has been installed, the auger boring rig retracts, and a new section of casing/augers are attached to continue excavation.

- Accuracy: ± 12 to 60 inches
- Pipe: 8- to 96-inch diameter (OD); Steel
- Typical length: < 400 feet
- Unsuitable: Groundwater table above the invert, rock is below the groundwater table, boulders
- Construction: Decreased length with increased diameter; May be used in conjunction with small boring unit in rock; Possible to withdraw auger to remove obstructions



Guided Boring

Adding auger boring to pilot tube enables longer/larger installations due to added power. A pilot bore is designed, constructed and left in place by use of pilot tube from the launch area to exit side. The guidance head is removed, but pilot tube left in place. The auger machine is attached to the pilot tubes, and by help of special adaptor and a regular auger boring sequence commences along the path of completed bore.

- Accuracy: ± 0.5 inches over 500 feet
- Pipe: 8- to 96-inch diameter (OD); Steel
- Typical length: < 400 feet
- Unsuitable: Groundwater table above the invert, hard rock below the groundwater table, boulders
- Construction: Possible to withdraw auger to remove obstructions



Intermediate Jacking Stations (IJS)

Cylindrical steel jackets with integrated hydraulic cylinders that are installed during pipe jacking at defined distances apart in the pipe string. These divide the entire pipe string into individual sections, thus reducing the required jacking force on the jacking frame in the launch shaft and enabling very long pipe jacking stretches. IJS can be used with any pipejacking method that allows personnel entry.

Hand Tunneling

Hand tunneling, also called conventional tunneling or hand mining, is typically done using shovels and pneumatic hand tools to excavate the soil or rock. Supports made of wood or metal are then installed to keep the tunnel from collapsing.

Hand tunneling is adaptable and flexible when encountering unexpected conditions such as buried utilities or unknown or difficult soil conditions. Hand tunneling can be used in combination with other trenchless tunneling methods when hard rock, boulders, or other obstructions are encountered. Drilling and blasting are sometimes required to remove large boulders from the excavation path which the boring equipment cannot handle.

For shorter tunnels, hand tunneling can be more economical than using a tunnel boring machine.

With hand tunneling, the workers require enough space in which to excavate the soil. The usual minimum size of pipe that can be installed using hand tunneling is 48 inches.

