

DEPARTMENT OF TRANSPORTATION
ENGINEERING SERVICE CENTER
Transportation Laboratory
5900 Folsom Blvd.
Sacramento, California 95819-4612



METHOD OF TEST FOR MOISTURE VAPOR SUSCEPTIBILITY OF BITUMINOUS MIXTURES

CAUTION: Prior to handling test materials, performing equipment setups, and/or conducting this method, testers are required to read "**SAFETY AND HEALTH**" in Section G of this method. It is the responsibility of the user of this method to consult and use appropriate safety and health practices and determine the applicability of regulatory limitations before any testing is performed.

CT 307 has been withdrawn (Feb. 2024). It is no longer maintained by Caltrans

A. SCOPE

The moisture vapor susceptibility test indicates the extent to which stabilometer values of bituminous mixtures are affected by moisture vapor.

B. APPARATUS

1. California stabilometer and accessories.
2. Testing machine, 220 kN capacity (minimum).
3. Oven, capable of maintaining $60 \pm 3^\circ\text{C}$ with a provision for air circulation.
4. Aluminum seal cap, 101.5 ± 0.05 mm diameter, approximately 1 mm thick (see Figure 2).
5. Circular felt pad, approximately 100 mm diameter by 6 mm thick.
6. Felt strip wick, approximately 6 by 50 by 200 mm.
7. Metal spring retaining clamp.
8. Tin-plated pan, approximately 32 mm deep by 97 mm in diameter.
9. Special pressing standard for applying aluminum seal caps (see Figure 1).
10. Silicone sealant.

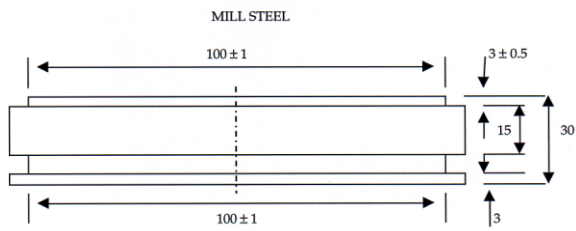
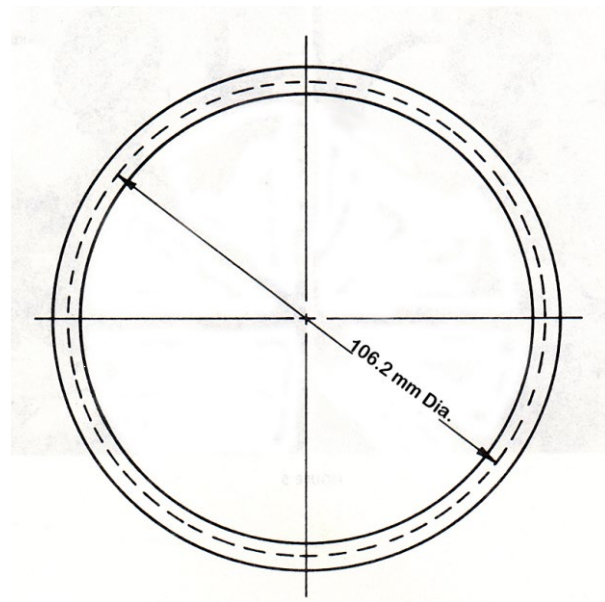

M.V.S. PRESSING STANDARD
(All dimensions in mm)
FIGURE 1

11. Compaction molds — stainless steel 101.6 ± 0.13 mm inside diameter by 127 ± 0.2 mm high.

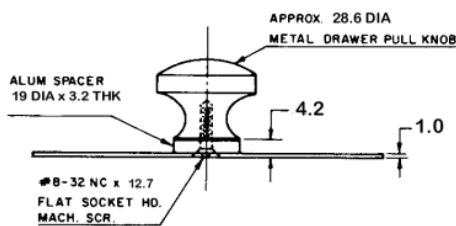
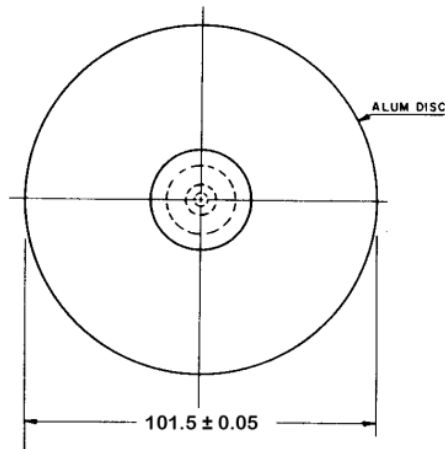

SEAL CAP
(All dimensions in mm)
FIGURE 2

C. PREPARATION OF SAMPLE

1. Mix and compact two test specimens as described in California Test 304, with the exception that the specimens shall be compacted in stainless steel molds.
2. Place an aluminum seal cap (see Figure 2) on the compacted surface of each specimen and apply a silicone sealant around the edges to prevent the escape of moisture vapor. To seal, use "Silicone Seal" (a commercial product by General Electric) or equivalent.
3. Place a presoaked circular felt pad against the bottom surface of each test specimen. Place a presoaked felt

strip wick in contact with each felt pad. Insert metal spring clamps to hold the wicks in place (see Figure 3).

4. Place a pan of water up into each mold, making certain that the free ends of the wicks are immersed.

D. TEST PROCEDURE

1. Place the assemblies in a 60 ± 3°C oven and leave for a continuous period of 75 ± 1 h.
2. Remove the specimen from the oven. Remove the aluminum seal caps and wick assemblies. With the tamped side up in the stabilometer, immediately determine the stabilometer value of each specimen using California Test 366 procedures.

E. NOTES

The water level should be maintained above the free ends of the strip wick throughout the 75-h period in the oven. Periodic visual checks will be required to make sure this is accomplished.

The stability test must be performed before any absorbed moisture escapes.

F. REPORTING OF RESULTS

Average the two test results and report to the nearest whole number.

G. SAFETY AND HEALTH

Prior to handling, testing or disposing of any waste materials, Caltrans testers are required to read: Part A (Section 5.0), Part B (Sections: 5.0, 6.0 and 10.0) and Part C (Section 1.0) of Caltrans Laboratory Safety Manual. Users of this method do so at their own risk.

REFERENCE:
California Tests 304 and 366

End of Text (California Test 307 contains 3 pages)

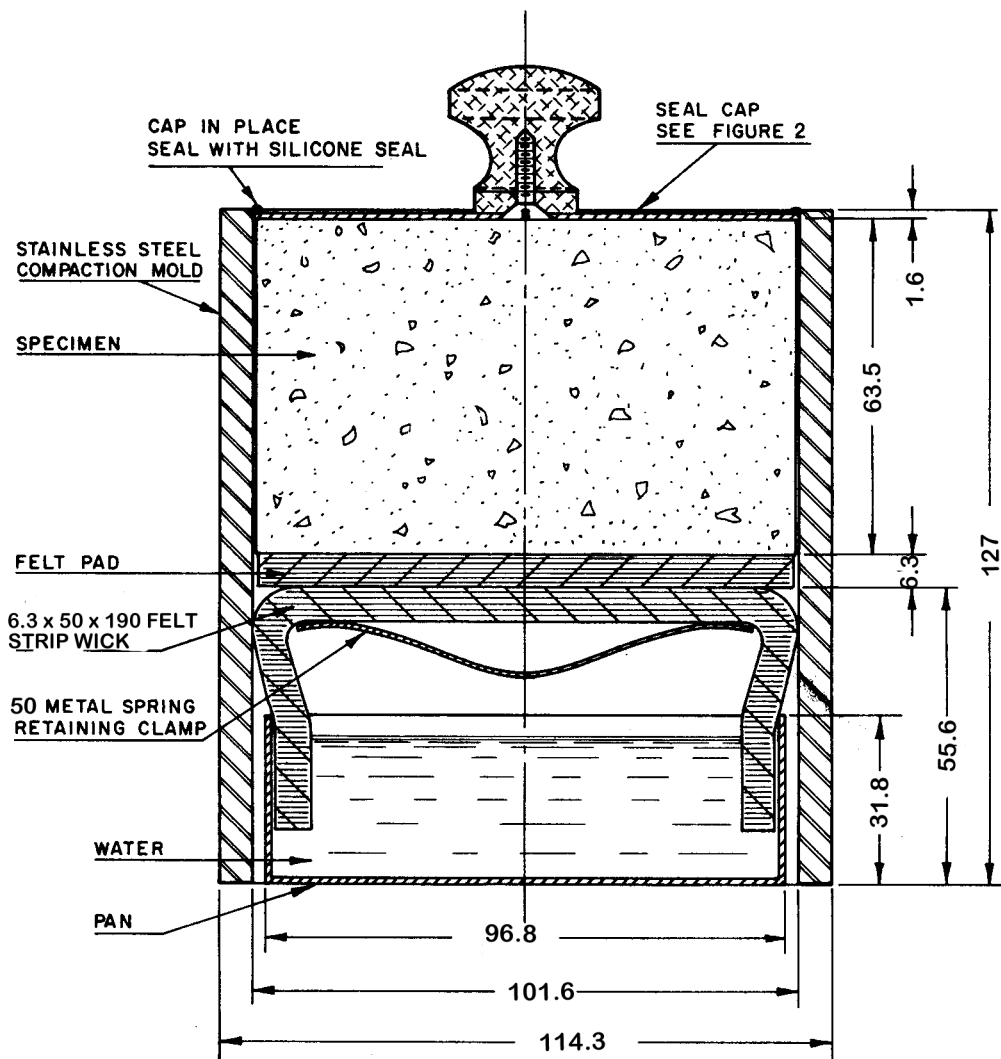

(All dimensions in mm)
 FIGURE 3