

5.5 PIPE-PIN CONNECTIONS IN CONCRETE BRIDGES

5.5.1 GENERAL

This BDM provides general guidance on the design and detailing recommendations for pipe-pin connections between concrete bridge bent caps and columns based on a combination of Caltrans' successful past practices and UNR research CCEER 10-01 *Seismic Design of Pipe-Pin Connections in Concrete Bridges* (Saiidi, 2010).

5.5.2 DEFINITIONS

Perfect Pin—A connection that transfers shear and axial forces, but zero bending moment, across the interface between two structural members.

Reduced Moment Connection—A connection that approximates the behavior of a perfect pin but transfers a small bending moment.

5.5.3 NOTATION

A_c	=	column area without pipe-pin pipe (in. ²)
A_{cp}	=	cross-sectional area of the concrete inside the pipe-pin pipe (in. ²)
A_g	=	cross-sectional area of the steel pipe (in. ²)
A_{sp1}	=	column shear reinforcement cross-sectional area (in. ²)
A_{sp2}	=	column inner shear reinforcement cross-sectional area (in. ²)
A_1	=	area under bearing device (in. ²)
A_2	=	notional area defined as shown in Figure 5.5.5.6-1 (in. ²)
B	=	diameter of circular or width of square column (in.)
$D_{bearing}$	=	outer diameter of bearing area (in.)
D_p	=	pipe-pin pipe outside diameter (in.)
d_1	=	column shear reinforcement cage diameter (in.)
d_2	=	column inner shear reinforcement cage diameter (in.)
e	=	eccentricity of the resultant load from the soffit (in.)
f_c'	=	concrete strength (ksi)
$f_{c',pipe}$	=	concrete strength for the filled concrete in the steel pipe (ksi)
$f_{n,bent cap}$	=	equivalent concrete bearing stress (ksi)
f_{yp}	=	steel pipe yield strength (ksi)
f_{ys}	=	shear reinforcement yield stress (ksi)

G	=	size of the gap between pipe and can (in.)
L_{can}	=	length of pipe-pin's steel can within the bent cap (in.)
L_{embed}	=	pipe embedment length in the column (in.)
m	=	confinement modification factor
M_p	=	flexural capacity of the concrete-filled pipe (kip*in.)
N_{max}	=	maximum effective axial load (kip)
P_{dl}	=	axial force due to dead load per SDC (kip)
P_n	=	nominal bearing capacity (kip)
P_o	=	maximum axial load associated with overstrength moment M_o (kip)
P_u	=	maximum factored axial load from the strength limit state (kip)
r_1	=	outer radius of the pipe (in.)
r_2	=	inner radius of the pipe (in.)
s_1	=	column shear reinforcement spacing (in.)
s_2	=	column inner shear reinforcement spacing (in.)
t_{pipe}	=	thickness of pipe (in.)
$V_o^{col-top}$	=	overstrength shear force demand at the top of column per SDC (kip)
$V_{nlb, column}$	=	nominal lower bound shear capacity at column (without axial load) (kip)
$V_{n,bent cap}$	=	nominal shear capacity at bent cap (kip)
$V_{n,column}$	=	nominal shear capacity of the pipe-pin at column by interpolating between nominal lower bound shear capacity ($V_{nlb,column}$) and upper bound ($V_{nub,column}$) capacities (kip)
V_{ni}	=	nominal shear capacity across the joint between column and bent cap (kip)
$V_{n, pipe}$	=	nominal shear capacity of the concrete-filled pipe (kip)
$V_{r,column}$	=	shear resistance of the pipe-pin at column (kip)
$V_{r,bent cap}$	=	shear resistance of the pipe-pin at bent cap (kip)
$V_{r,pipe}$	=	shear resistance by the bending of the cantilever pipe (kip)
$V_{r,pipe-pin}$	=	shear resistance of pipe-pin (kip)
$V_{nub,column}$	=	nominal upper bound shear capacity at column (kip)
Z_{pipe}	=	plastic section modulus (in. ³)
ϕ	=	shear strength reduction factor
ϕ_{Pu}	=	bearing reduction factor at the strength limit state.
ϕ_{Po}	=	bearing reduction factor with overstrength demand.

5.5.4 TYPE OF CONNECTIONS

Connections between columns and bent caps are commonly either pinned or fixed. The selection of connection type depends on several factors, such as bridge geometry, the number of columns, deflection demands, etc.

5.5.4.1 Pinned Connections

A pinned connection limits the transfer of bending moments between the bent cap and the column. Both pipe-pin and rebar-pin connection types are commonly utilized:

- Pipe-pin connections can be modeled as *perfect pins* for structural analysis and capacity design, transferring only shear and axial forces without resisting bending moments. A concrete-filled steel pipe acting as a shear pin is extended into an oversized steel can, which is embedded in the bent cap (see Fig. 5.5.4.1-1).

A gap between the steel can and the pipe allows the pipe to rotate freely inside the can. The mechanical interaction between the pipe and the can transfers a significant portion of the shear load. The pipe-pin assembly should be galvanized or fabricated of stainless steel for corrosion protection.

This BDM focuses on pipe-pin connections between the bent cap and column, covering recommended construction details and design guidance.

- The rebar-pin connection has been traditionally assumed to be a perfect-pin connection. In this detail, the column's main longitudinal reinforcement terminates at the end of the column, and a small number of shorter concentrically positioned reinforcing bars are placed at the center of the column and extending into the bent cap (see Fig. 5.5.4.1-2) or foundation element to establish the connection. The rebar-pin connection is considered a *reduced moment connection*, and any moment transferred by the connection should be accounted for in the design. Although the past practice has shown that the rebar-pin detail has performed adequately when designed as a perfect pin. Reinforcement that crosses the interface should be galvanized or fabricated of stainless steel for corrosion protection.

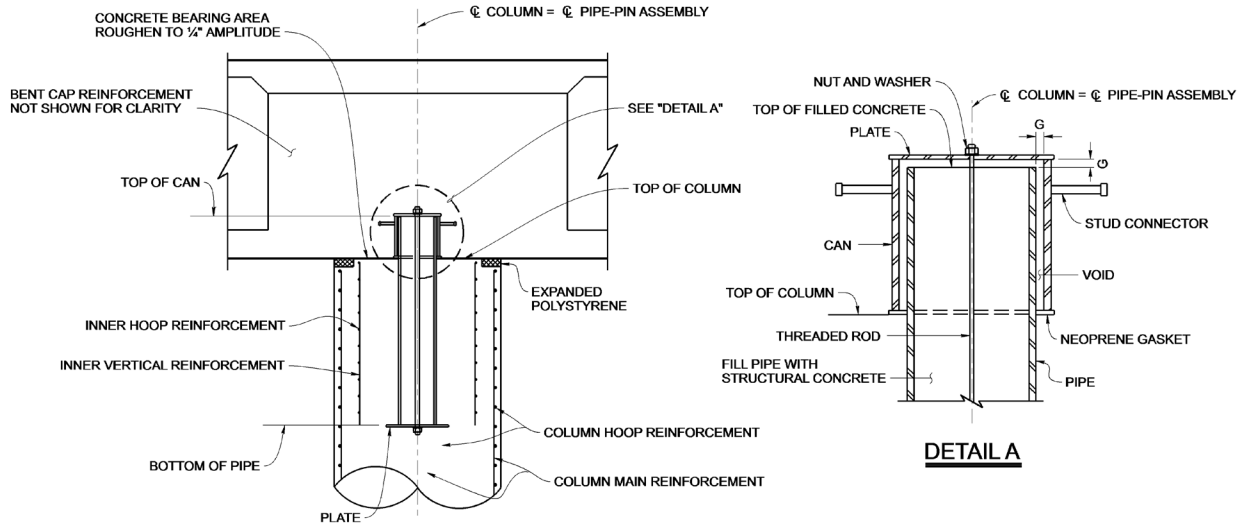

Figure 5.5.4.1-1 Pipe-Pin Details

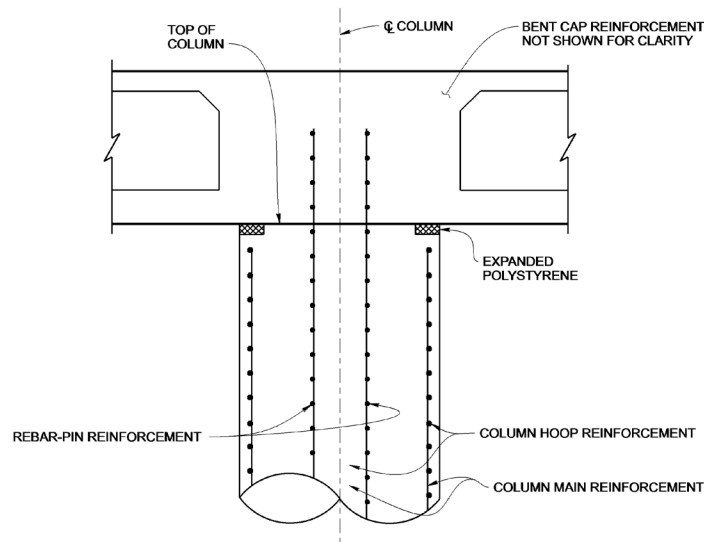

Figure 5.5.4.1-2 Rebar-Pin Details

5.5.5 PIPE-PIN DESIGN PROCEDURE

5.5.5.1 Design Overview

Referring to the research by Zaghi and Saiidi (2010), the design of the pipe-pin connection consists of three components, and its shear resistance is expressed as: (1) the column with an embedded pipe, $V_{r,column}$, (2) the bent cap with an embedded steel can, $V_{r,bent\ cap}$, and (3) the concrete-filled pipe, $V_{r,pipe}$. Note that the shear resistance of the concrete-filled pipe, $V_{r,pipe}$ is part of the shear resistance determination of $V_{r,column}$ and $V_{r,bent\ cap}$, and it is not directly used to determine the overall shear resistance of the pipe-pin, $V_{r,pipe-pin}$.

$V_{r,pipe-pin}$ should be greater than the overstrength shear demand force in the extreme limit state, $V_o^{col-top}$.

$$V_{r,pipe\ pin} = \min \begin{cases} V_{r,column} \\ V_{r,bent\ cap} \end{cases}$$

$$V_{r,pipe\ pin} \geq V_o^{col-top}$$

5.5.5.2 Research Recommendations

Below are a series of recommendations and assumptions developed from numerous parametric analyses performed by Zaghi and Saiidi (2010):

- a) The pipe embedment length (L_{embed}) in the column should be at least 4.5 times the pipe-pin diameter ($4.5D_p$)
- b) The length of the pipe-pin can (L_{can}) within the bent cap should be 1.2 times the pipe-pin diameter ($1.2D_p$)
- c) The minimum thickness of the can and the pipe should be 0.5 inches.
- d) The pipe should be encased in a large amount of concrete within the bent cap to ensure adequate confinement.
- e) Install studs around the circumference, welded to the upper section of the can to maintain positional stability within the bent cap.
- f) A bearing area at the top of the column with 1 inch thickness may result in localized concrete spalling at the bearing area edge under large lateral displacements; such minor damage is considered repairable after an earthquake.
- g) The inner shear reinforcement diameter should be 3 times the pipe-pin diameter ($3D_p$).
- h) The gap, G , clearance of $D_p/20$ between the pipe and the can is recommended to accommodate the anticipated rotational deformation of the pipe-pin within the can.
- i) The shear reinforcement at the top of the column should be designed to meet the target strength of the pipe-pin connection. The research analysis found that the shear reinforcement at the top of the column contributed a significant capacity due to the shear failure plane intersecting the shear reinforcement at that location.
- j) Most bent caps contain sufficient confinement through the presence of flexural reinforcement and stirrups in close proximity to the can, thereby eliminating the need for supplemental confinement reinforcement.

Table 5.5.5.2-1 Suggested Pipe-Pin Parameters

COLUMN DIAMETER	4'-0"	5'-0"	5'-6"	6'-0"	7'-0"
MAX DIAMETER OF CONCRETE BEARING AREA	2'-11"	3'-11"	4'-2"	4'-5"	4'-11"
L _{embed}	4'-6"	5'-3"	5'-3"	6'-0"	6'-0"
L _{can}	1'-3"	1'-6"	1'-6"	1'-9"	1'-9"
CAN SIZE	(ROUND) HSS 14.00X0.50	(ROUND) HSS 18.00X1.00	(ROUND) HSS 18.00X1.00	(ROUND) HSS 20.00X1.00	(ROUND) HSS 20.00X1.00
PIPE SIZE	(ROUND) HSS 11.75X0.50	(ROUND) HSS 14.00X0.50	(ROUND) HSS 14.00X0.50	(ROUND) HSS 16.00X0.50	(ROUND) HSS 16.00X0.75
GAP SIZE	0.625"	1.0"	1.0"	1.0"	1.0"

Note: The suggested round HSS dimensions are based on ASTM A500 Grade B ($f_{yp} = 46$ ksi). The designer should also confirm the availability of HSS sizes and thicknesses when using different dimensions or materials.

5.5.5.3 Determining Pipe-Pin Shear Capacity at Column

Step 1. Determine the nominal shear capacity without axial load, $V_{nlb,column}$. Shear resistance of the pipe-pin is calculated when no friction and axial load effects are involved.

The nominal shear capacity of the concrete-filled pipe, $V_{n,pipe}$, needs to be larger than the $V_{nlb,column}$.

$$V_{n,pipe} = \frac{2A_g f_{yp}}{\pi\sqrt{3}} + 0.93A_{cp}\sqrt{f'_{c,pipe}} \quad (\text{Eq. 5.5.5.3-1})$$

Estimate the flexural capacity, M_p , of the concrete-filled pipe. This equation was developed based on moment-curvature analysis of several cases by Zaghi and Saidi (2010).

$$M_p = 1.1f_{yp}Z_{pipe} \quad (\text{Eq. 5.5.5.3-2})$$

$$Z_{pipe} = \frac{4}{3}(r_1^3 - r_2^3) \quad (\text{Eq. 5.5.5.3-3})$$

Calculate the nominal shear capacity without axial load, $V_{nlb,column}$.

$$V_{nlb,column} = \min \left\{ \begin{array}{l} 1.17\sqrt{M_p D_p f'_c} \\ V_{n,pipe} \end{array} \right. \quad (\text{Eq. 5.5.5.3-4})$$

Step 2. Calculate the upper limit shear capacity.

$$V_{nub,column} = F1 \times \left(0.16 A_c \sqrt{f'_c} + \frac{A_{sp1} f_{ys} d_1}{s_1} \right) + \frac{A_{sp2} f_{ys} d_2}{s_2} + \frac{1.45 M_p}{D_{bearing} + D_p} \quad (\text{Eq. 5.5.5.3-5})$$

$$F1 = 0.45 \frac{D_{bearing}}{B} + 0.6 \quad (\text{Eq. 5.5.5.3-6})$$

For a circular column:

$$A_c = \frac{\pi}{4} (B^2 - D_p^2) \quad (\text{Eq. 5.5.5.3-7})$$

For a square column:

$$A_c = B^2 - \frac{\pi D_p^2}{4} \quad (\text{Eq. 5.5.5.3-8})$$

Calculate the maximum effective axial load:

$$N_{max} = F1 \times A_c \quad (\text{Eq. 5.5.5.3-9})$$

The shear resistance can be determined by the following equations.

$$V_{n,column} = V_{nlb,column} + (V_{nub,column} - V_{nlb,column}) \left(\frac{P_{dl}}{N_{max}} \right)^{0.7} \quad (\text{Eq. 5.5.5.3-10})$$

$$V_{r,column} = \phi (V_{n,column}) \quad (\text{Eq. 5.5.5.3-11})$$

$\phi = 0.75$ for the strength limit state, and 1.0 for the extreme limit state.

5.5.5.4 Determining Pipe Shear Capacity at Bent Cap

The governing failure mode or failure mechanism for the pipe-pin is unlikely to be caused by concrete cracking, as the pipe-pin is surrounded by a large amount of concrete structure of the bent cap. Instead, its capacity is generally governed by either the bearing failure of the concrete or the shear failure of the concrete-filled pipe. The flexural capacity of the pipe is determined using Eq. 5.5.5.3-2, consistent with the approach used for the pipe-pin at the column.

The capacity of the pipe-pin at the bent cap, $V_{n,bent\ cap}$, excluding the effects of friction, is determined as follows:

$$V_{n,bent\ cap} = \min \left\{ \begin{array}{l} D_p f_{n,bent\ cap} \left(\sqrt{e^2 + \frac{2.2 f_{yp} Z_{pipe}}{D_p f_{n,bent\ cap}}} - e \right) \\ V_{n,pipe} \end{array} \right. \quad (\text{Eq. 5.5.5.4-1})$$

Eccentricity, e , of the resultant load from the surface, is conservatively taken as:

$$e = 0.3D_p$$

Use Eq. 5.5.5.4-2 to determine the equivalent uniform bearing strength of concrete against the pipe.

With inner shear reinforcement:

$$f_{n,bent\ cap} = \frac{\sqrt{f'_c}}{2.43} \left(2.95 - \frac{\sqrt[3]{D_p}}{3.35} \right) f'_c \quad (\text{Eq. 5.5.5.4-2})$$

Without inner shear reinforcement:

$$f_{n,bent\ cap} = 0.9 \left(\frac{\sqrt{f'_c}}{2.43} \left(2.95 - \frac{\sqrt[3]{D_p}}{3.35} \right) f'_c \right)$$

To determine the bent cap shear capacity, the contribution of interface shear friction needs to be added to $V_{n,bent\ cap}$. The strength reduction factor $\phi = 0.75$ for the strength limit state and 1.0 for the extreme limit state also needs to be applied:

$$V_{r,bent\ cap} = \phi (V_{n,bent\ cap} + V_{ni})$$

Modified the AASHTO equation 5.11.4.4, the nominal shear capacity across the joint, V_{ni} , is as follows.

$$V_{ni} = 0.75P_{dl} \quad (\text{Eq. 5.5.5.4-3})$$

Where:

There is no reinforcement across the joint in this pipe-pin design scenario.

Accordingly, the shear resistance of the bent cap, $V_{r,bent\ cap}$, can be expressed using the following equations.

$$V_{r,bent\ cap} = \phi (V_{n,bent\ cap} + 0.75P_{dl}) \quad (\text{Eq. 5.5.5.4-4})$$

5.5.5.5 Pipe-Pin Shear Capacity Determination

As explained in section 5.5.5.1, the shear resistance of the pipe-pin, $V_{r,pipe-pin}$, can be defined as follows:

$$V_{r,pipe-pin} = \min \begin{cases} V_{r,column} \\ V_{r,bent\ cap} \end{cases} \quad (\text{Eq. 5.5.5.5-1})$$

$$V_{r,pipe-pin} \geq V_o^{col-top} \quad (\text{Eq. 5.5.5.5-2})$$

5.5.5.6 Minimum Concrete Bearing Surface Area

Per AASHTO 5.6.5, the nominal bearing capacity should be taken as:

$$P_n = 0.85f'_c A_1 m \quad (\text{Eq. 5.5.5.6-1})$$

Where the loaded area is considered to be a nonuniformly distributed bearing stress:

$$m = 0.75 \sqrt{\frac{A_2}{A_1}} \leq 1.50 \quad (\text{Eq. 5.5.5.6-2})$$

The top corner of the column is trimmed and filled with expanded polystyrene to accommodate rotational displacement from the superstructure. As a result, the axial load transfer between A_1 and A_2 is interrupted. Hence, $A_1 = A_2$ is assumed, and m is taken as 0.75.

The factored nominal bearing capacity, ϕP_n , must exceed both the maximum factored axial load demand from the strength limit state, P_u , and the maximum axial load corresponding to the overstrength moment, P_o , with corresponding bearing reduction factors $\phi_{P_u} = 0.70$ and $\phi_{P_o} = 1.00$.

$$\phi P_n \geq \begin{cases} P_u; & \phi_{P_u} = 0.70 \\ P_o; & \phi_{P_o} = 1.00 \end{cases} \quad (\text{Eq. 5.5.5.6-3})$$

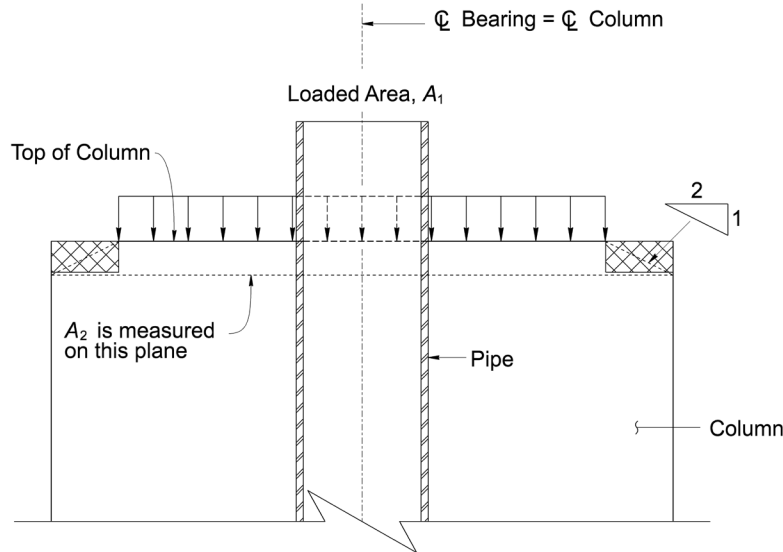

Figure 5.5.5.6-1 Determination of Notional Area

Table 5.5.5.2-1 provides examples of column size along with the corresponding maximum allowable pipe-pin bearing diameters.

5.5.6 DESIGN EXAMPLE

Here is a design example for calculating the pipe-pin assembly shear resistance in a 5-ft diameter column with a length of 18.5 ft and an axial load of 1100 kips on the column during an earthquake. The can is ASTM A500 Round HSS 18 x 1.00, and the pipe is ASTM A500 Round HSS 14.00 x 0.50. The material characteristics, reinforcement details, and other details are listed here:

A_{sp1}	=	#8	L_{embed}	=	63 in.
A_{sp2}	=	#5	P_{dl}	=	1100 kips
d_1	=	55.13 in.	P_o	=	1900 kips
d_2	=	42 in.	P_u	=	2300 kips
D_p	=	12.75 in.	s_1	=	6 in.
f'_c	=	3.6 ksi	s_2	=	6 in.
$f'_{c,pipe}$	=	3.6 ksi	t_{pipe}	=	0.5 in.
f_{yp}	=	46 ksi	$V_o^{col-top}$	=	600 kips
f_{ys}	=	60 ksi	ϕ	=	1.0
G	=	1 in.	ϕ_{P_u}	=	0.7
L_{can}	=	18 in.	ϕ_{P_o}	=	1.0

Top of Column Pipe-Pin Connection Design Example

General Input:

			Legend:
f'_c	= concrete strength (ksi)	$f'_c := 3.60$ ksi	Input
f'_{c_pipe}	= concrete strength for filled concrete in the steel pipe (ksi)	$f'_{c_pipe} := 3.60$ ksi	Calculated
f_{ys}	= shear reinforcement yield stress (ksi)	$f_{ys} := 60.00$ ksi	Reference
ϕ	= shear strength reduction factor	$\phi := 1.00$	
ϕ_{Pu}	= bearing reduction factor at strength limit state	$\phi_{Pu} := 0.70$	AASHTO 5.5.4.2
ϕ_{Po}	= bearing reduction factor with overstrength demand	$\phi_{Po} := 1.00$	

Load Demand Input

$V_{o_col_top}$	= overstrength shear force demand at the top of column per SDC (kip)	$V_{o_col_top} := 600.00$ kip
P_{dl}	= axial force due to dead load per SDC (kip)	$P_{dl} := 1100.00$ kip
P_u	= the maximum factored axial load from the strength limit state (kip)	$P_u := 2300.00$ kip
P_o	= the maximum axial load associated with overstrength moment M_o (kip)	$P_o := 1900.00$ kip

Pipe-Pin Parameter Input:

f_{yp}	= steel pipe yield strength (ksi)	$f_{yp} := 46.00$ ksi
G	= side of the gap between pipe and can (in.)	$G := 1.00$ in
D_p	= pipe-pin pipe outside diameter (in.)	$D_p := 14.00$ in
t_{pipe}	= thickness of pipe (in.)	$t_{pipe} := 0.50$ in
$D_{bearing}$	= outer diameter of bearing area (in.)	$D_{bearing} := 47.00$ in
$D_{bearing_max}$	= approximate 75% of column diameter (in.)	$D_{bearing_max} := 47.00$ in
r_1	= outer radius of the pipe (in.)	$r_1 := \frac{D_p}{2} = 7.00$ in

r_2 = inner radius of the pipe (in.) $r_2 := r_1 - t_{pipe} = 6.50$ in

L_{embed} = the pipe embedment length in the column (in.) $L_{embed} := 63.00$ in

L_{can} = length of pipe-pin's steel can within the bent cap (in.) $L_{can} := 18.00$ in

Column Parameter Input:

B = diameter of the circular or width of the square column (in.) $B := 60$ in

$Size_{sp1}$ = column shear reinforcement (hoop or spiral) size $Size_{sp1} := \#8$ ▼

A_{Size_sp1} = single rebar area of column shear reinforcement (in.²) $A_{Size_sp1} := Size_{sp1_2} \text{ in}^2 = 0.79 \text{ in}^2$

$Bundle_{sp1}$ = number of reinforcement in a bundle for column shear reinforcement $Bundle_{sp1} := 1$ ▼

$Size_{sp2}$ = column inner shear reinforcement (hoop or spiral) size $Size_{sp2} := \#5$ ▼

A_{Size_sp2} = single rebar area of column inner shear reinforcement (in.²) $A_{Size_sp2} := Size_{sp2_2} \text{ in}^2 = 0.31 \text{ in}^2$

$Bundle_{sp2}$ = number of reinforcement in a bundle for column inner shear reinforcement $Bundle_{sp2} := 1$ ▼

A_{sp1} = column shear reinforcement cross-sectional area (in.²) $A_{sp1} := A_{Size_sp1} \cdot Bundle_{sp1} = 0.79 \text{ in}^2$

A_{sp2} = column inner shear reinforcement cross-sectional area (in.²) $A_{sp2} := A_{Size_sp2} \cdot Bundle_{sp2} = 0.31 \text{ in}^2$

s_1 = column shear reinforcement spacing (in.) $s_1 := 6.00$ in

s_2 = column inner shear reinforcement spacing (in.) $s_2 := 6.00$ in

clr = concrete cover (in.) $clr := 2.00$ in

d_1 = column shear reinforcement cage diameter (in.) $d_1 := B - 2 \text{ clr} - Size_{sp1_1} \text{ in} = 55.00 \text{ in}$

d_2 = column inner shear reinforcement cage diameter (in.) $d_2 := 42.00$ in

L_c = length of column (in.)

$$L_c := 18.5 \text{ ft} = 222.00 \text{ in}$$

Research Recommendations (refer to Section 5.5.5.2)

a) Recommended pipe embedment length = $4.5 D_p$ $L_{embed_rec.} \geq 4.5 \cdot D_p$

$$L_{embed_rec.} := 4.5 \cdot D_p = 63.00 \text{ in}$$

L_{embed} = the pipe embedment length in the column (in.)

$$L_{embed} = 63.00 \text{ in}$$

Check, if $(L_{embed_rec.} \leq L_{embed}, \text{"O.K!"}, \text{"N.G!"}) = \text{"O.K!"}$

b) Recommended can length = $1.2 D_p$

$$L_{can_rec.} = 1.2 \cdot D_p$$

$$L_{can_rec.} := 1.2 \cdot D_p = 16.80 \text{ in}$$

L_{can} = length of pipe-pin can within the bent cap (in.)

$$L_{can} = 18.00 \text{ in}$$

Check, if $(L_{can_rec.} \leq L_{can}, \text{"O.K!"}, \text{"N.G!"}) = \text{"O.K!"}$

c) Minimal thickness of pipe is 0.5 in.

$$t_{pipe_min} := 0.5 \text{ in}$$

t_{pipe} = thickness of pipe (in.)

$$t_{pipe} = 0.50 \text{ in}$$

Check, if $(t_{pipe_min} \leq t_{pipe}, \text{"O.K!"}, \text{"N.G!"}) = \text{"O.K!"}$

g) Recommended inner hoop diameter of $3 D_p$

$$d_{2_rec.} := 3 D_p = 42.00 \text{ in}$$

d_2 = column inner shear reinforcement cage diameter (in.)

$$d_2 = 42.00 \text{ in}$$

Check, if $(d_{2_rec.} \leq d_2, \text{"O.K!"}, \text{"N.G!"}) = \text{"O.K!"}$

h) Recommended gap clearance between the pipe and the steel can

$$G_{rec.} := \frac{D_p}{20} = 0.70 \text{ in}$$

G = side gap between pipe and can (in.)

$$G = 1.00 \text{ in}$$

Check, if $(G \geq G_{rec.}, \text{"O.K!"}, \text{"N.G!"}) = \text{"O.K!"}$

Determining Pipe-Pin Shear Capacity at Column (refer to Section 5.5.5.3)

Step 1: Determining the nominal lateral load capacity without axial load, V_{nlb_column}

A_g = cross-sectional area of the steel pipe (in.²)

$$A_g := \pi \cdot (r_1^2 - r_2^2) = 21.21 \text{ in}^2$$

A_{cp} = cross-sectional area of the concrete inside the pipe-pin pipe (in.²)

$$A_{cp} := \pi \cdot r_2^2 = 132.73 \text{ in}^2$$

Nominal shear capacity of the concrete-filled pipe,

$$V_{n_pipe} := \left(\frac{2 \cdot \frac{A_g}{\text{in}^2} \cdot \frac{f_{yp}}{\text{ksi}}}{\pi \cdot \sqrt{3}} + 0.93 \cdot \frac{A_{cp}}{\text{in}^2} \cdot \sqrt{\frac{f'_{c_pipe}}{\text{ksi}}} \right) \text{ kip}$$

Eq. 5.5.5.3-1

$$V_{n_pipe} = 592.75 \text{ kip}$$

Z_{pipe} = plastic section modulus (in.³)

$$Z_{pipe} := \frac{4}{3} (r_1^3 - r_2^3)$$

Eq. 5.5.5.3-3

$$Z_{pipe} = 91.17 \text{ in}^3$$

M_p = flexural capacity of the concrete-filled pipe (kip·in.)

$$M_p := 1.1 \cdot f_{yp} \cdot Z_{pipe}$$

Eq. 5.5.5.3-2

$$M_p = 4613.03 \text{ kip} \cdot \text{in}$$

V_{nlb_column} = nominal lower bound shear capacity at column (without axial load)(kip)

$$V_{nlb_column} := \min \left(1.17 \cdot \sqrt{M_p \cdot D_p \cdot f'_c}, V_{n_pipe} \right)$$

Eq. 5.5.5.3-4

$$V_{nlb_column} = 564.15 \text{ kip}$$

Step 2: Calculate the upper limit shear capacity, V_{nub_column}

Factor 1,

$$F1 := 0.45 \cdot \frac{D_{bearing}}{B} + 0.6$$

Eq. 5.5.5.3-6

$$F1 = 0.95$$

A_c = column area without pipe-pin pipe (in.²)

$$A_c := \frac{\pi}{4} \cdot (B^2 - D_p^2)$$

Eq. 5.5.5.3-7

$$A_c = 2673.5 \text{ in}^2$$

V_{nup_column} = nominal upper bound shear capacity at column (kip)

$$V_{nup_column} := \left(F1 \cdot \left(0.16 \cdot \frac{A_c}{\text{in}^2} \cdot \sqrt{\frac{f'_c}{\text{ksi}}} + \frac{\frac{A_{sp1}}{\text{in}^2} \cdot \frac{f_{ys}}{\text{ksi}} \cdot \frac{d_1}{\text{in}}}{\frac{s_1}{\text{in}}} \right) + \frac{\frac{A_{sp2}}{\text{in}^2} \cdot \frac{f_{ys}}{\text{ksi}} \cdot \frac{d_2}{\text{in}}}{\frac{s_2}{\text{in}}} + \frac{1.45 \cdot \frac{M_p}{\text{kip} \cdot \text{in}}}{\frac{D_{bearing}}{\text{in}} + \frac{D_p}{\text{in}}} \right) \text{ kip}$$

Eq. 5.5.5.3-5

$$V_{nup_column} = 1426.78 \text{ kip}$$

$$N_{max} = \text{maximum effective axial load (kip)} \quad N_{max} := F1 \cdot \frac{A_c}{\text{in}^2} \text{ kip} \quad \text{Eq. 5.5.5.3-9}$$

$$N_{max} = 2546.5 \text{ kip}$$

V_{n_column} = nominal shear capacity of the pipe-pin hinge at column (kip)

$$V_{n_column} := V_{nlb_column} + (V_{nup_column} - V_{nlb_column}) \cdot \left(\frac{P_{dl}}{N_{max}} \right)^{0.7} \quad \text{Eq. 5.5.5.3-10}$$

$$V_{n_column} = 1043.48 \text{ kip}$$

V_{r_column} = the shear resistance of the pipe-pin hinge at column (kip)

$$V_{r_column} := \phi \cdot V_{n_column} \quad \text{Eq. 5.5.5.3-11}$$

$$V_{r_column} = 1043.48 \text{ kip}$$

Determining Pipe-Pin Shear Capacity at Bent Cap (refer to Section 5.5.5.4)

$$f_{n_bent_cap} = \text{equivalent concrete bearing stress (ksi)} \quad f_{n_bent_cap} := \frac{\sqrt{\frac{f'_c}{\text{ksi}}}}{2.43} \left(2.95 - \frac{\sqrt[3]{\frac{D_p}{\text{in}}}}{3.35} \right) f'_c \quad \text{Eq. 5.5.5.4-2}$$

$$f_{n_bent_cap} = 6.27 \text{ ksi}$$

e = eccentricity of the resultant load from the soffit (in.)

$$e := 0.3 \cdot D_p$$

$$e = 4.2 \text{ in}$$

$V_{n_bent_cap}$ = nominal shear capacity at bent cap (kip)

$$D_p \cdot f_{n_bent_cap} \cdot \left(\sqrt{e^2 + \frac{2.2 \cdot f_{yp} \cdot Z_{pipe}}{D_p \cdot f_{n_bent_cap}}} - e \right) = 603.84 \text{ kip} \quad \text{Eq. 5.5.5.4-1}$$

$$V_{n_bent_cap} := \min \left(D_p \cdot f_{n_bent_cap} \cdot \left(\sqrt{e^2 + \frac{2.2 \cdot f_{yp} \cdot Z_{pipe}}{D_p \cdot f_{n_bent_cap}}} - e \right), V_{n_pipe} \right) \quad \text{Eq. 5.5.5.4-1}$$

$$V_{n_bent_cap} = 592.75 \text{ kip}$$

$V_{r_bent_cap}$ = shear resistance of the pipe-pin at bent cap (kip)

$$\text{Eq. 5.5.5.4-4}$$

$$V_{r_bent_cap} := \phi \cdot (V_{n_bent_cap} + 0.75 \cdot P_{dl})$$

$$V_{r_bent_cap} = 1417.75 \text{ kip}$$

Pipe-Pin Shear Capacity Determination (refer to Section 5.5.5.5)

Therefore, total shear resistance of the pipe-pin is:

$$V_{r_pipe_pin} := \min(V_{r_column}, V_{r_bent_cap}) = 1043.48 \text{ kip} \quad \text{Eq. 5.5.5.5-1}$$

$$V_{o_col_top} = 600.00 \text{ kip}$$

The designer should check the pipe-pin resistance with the shear demand

Check, if $(V_{o_col_top} \leq V_{r_pipe_pin}, \text{"O.K!"}, \text{"N.G!"}) = \text{"O.K!"}$

Minimum Concrete Bearing Surface Area (refer to Section 5.5.5.6)

Bearing Area requirement

$$D_{bearing} = \text{outer diameter of bearing area (in.)} \quad D_{bearing} = 47.00 \text{ in}$$

$$D_{bearing_max} = 47.00 \text{ in}$$

$$m = \text{confinement modification factor (in.)}, \quad m := 0.75 \quad \text{Eq. 5.5.5.6-2}$$

Assumed $A_1 = A_2$

Check, if $(m \leq 1.5, \text{"O.K!"}, \text{"N.G!"}) = \text{"O.K!"}$

$$A_{1_pu} = \text{bearing area for strength limit state (in.}^2\text{)} \quad A_{1_pu} := \frac{P_u}{0.85 \cdot \phi_{Pu} \cdot f'_c \cdot m} \quad \text{Eq. 5.5.5.6-1}$$

$$A_{1_pu} = 1431.68 \text{ in}^2$$

$$A_{1_po} = \text{bearing area for overstrength demand (in.}^2\text{)} \quad A_{1_po} := \frac{P_o}{0.85 \cdot \phi_{Po} \cdot f'_c \cdot m} \quad \text{Eq. 5.5.5.6-1}$$

$$A_{1_po} = 827.89 \text{ in}^2$$

$$A_{1_req.} = \text{the required concrete bearing area at the top of the column (in.}^2\text{)} \quad A_{1_req.} := \max(A_{1_pu}, A_{1_po}) = 1431.68 \text{ in}^2$$

$$D_{bearing_req.} = \text{required diameter of bearing area (in.)} \quad D_{bearing_req.} := \sqrt{\frac{4 A_{1_req.}}{\pi} + D_p^2}$$

$$D_{bearing_req.} = 44.93 \text{ in}$$

Check, if $(D_{bearing_req.} \leq D_{bearing}, \text{"O.K!"}, \text{"N.G!"}) = \text{"O.K!"}$

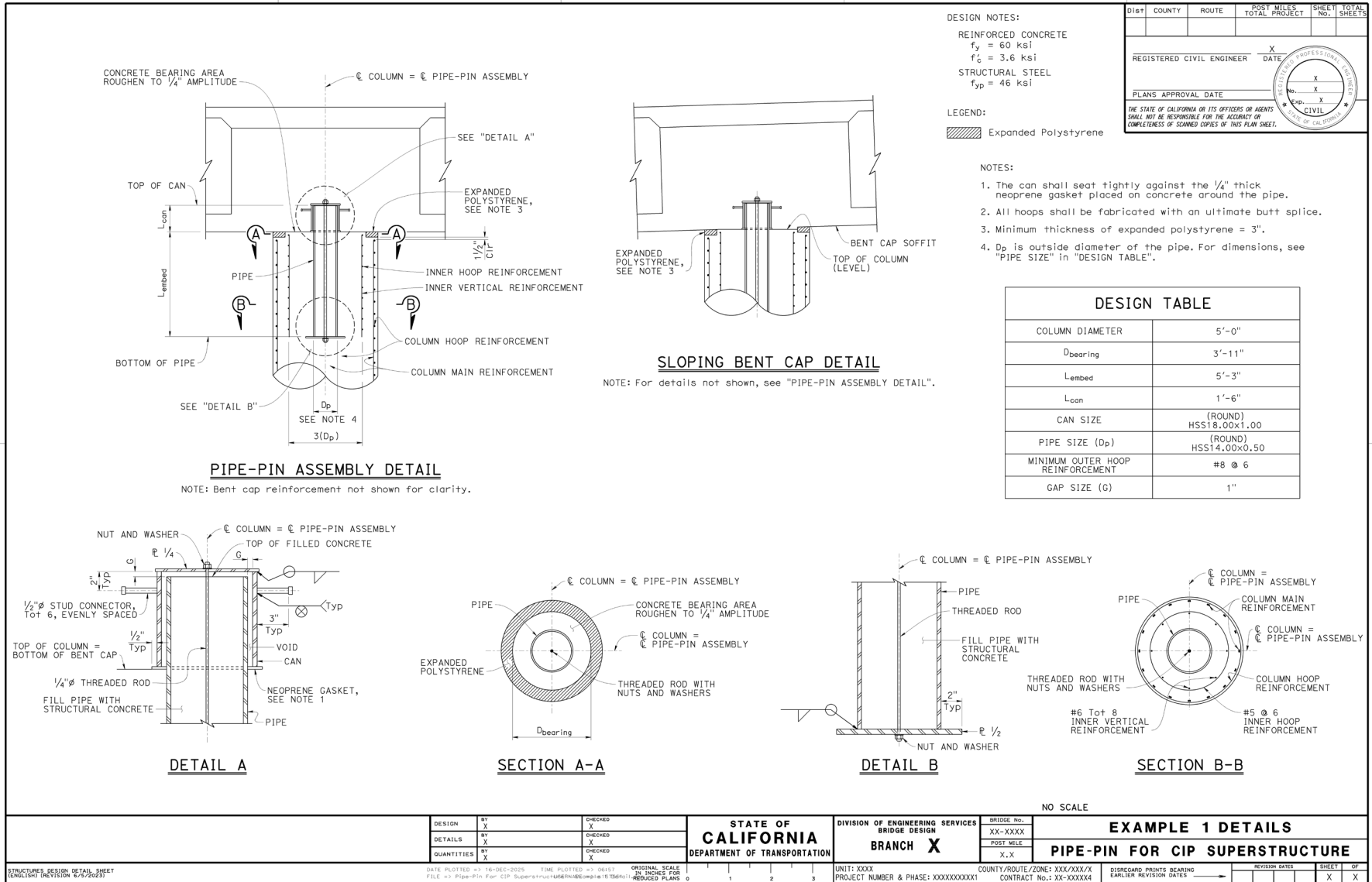

Figure 5.5.6-1 Pipe-Pin Example Detail

5.5.7 REFERENCES

1. AASHTO. (2017). *AASHTO LRFD Bridge Design Specifications*, 8th Edition, American Association of State Highway and Transportation Officials, Washington, DC.
2. ASTM A500/A500M (2023). *Standard Specification for Cold-Formed Welded and Seamless Carbon Steel Structural Tubing in Rounds and Shapes*, ASTM International.
3. Caltrans. (2025). *Caltrans Seismic Design Criteria*, Version 2.1, California Department of Transportation, Sacramento, CA. Add specification.
4. Caltrans. (2019). *California Amendments to AASHTO LRFD Bridge Design Specifications*, 8th Edition, California Department of Transportation, Sacramento, CA.
5. Zaghi, A. E., and Saiidi, M., *Seismic Design of Pipe-Pin Connections in Concrete Bridges*, Center for Civil Engineering Earthquake Research, Department of Civil and Environmental Engineering, University of Nevada, Reno, Nevada, Report No. CCEER-10-01, January 2010.