



Bridge Design Details 1.1 January 2023

General Detailing

Structure Plans shall be detailed and arranged in such a manner that a contractor can quickly understand the scope of the work to be done, calculate quantities to estimate construction costs, and construct the project. Keep in mind that once a contract is awarded, the plans become an enforceable part of a contract from which a structure is built. Contractors and subcontractors have a very short timeline to prepare bids. A clear set of plans increases the probability of competitive and reasonable bids from contractors.

When detailing or reviewing plans:

- If DETAILS or SECTIONS are not shown on the sheet to which they pertain, a cross reference shall be noted on the plans. This note shall be placed on the appropriate sheet referring to the sheet where the SECTION is cut, or the DETAIL is located. SECTIONS and DETAILS shall always be referenced in both directions.
- Whole words are preferred over abbreviations. If abbreviations are used, make sure they are ones defined in the *Standard Plans* (A3A, A3B, A3C and B0-1), a collegiate dictionary, or are more familiar than the non-abbreviated version (e.g., PVC pipe).
- Dimensioning and detail call-outs should generally not appear in more than one place within a set of structure plans. Dimension duplication may create a problem if a dimension is changed on one detail and not on the other.
- Exact and proper names of all bid items shall be used throughout the plans. Refer to *Bridge Design Aids: 11 Estimating*, or the Structure Office Engineer website for further guidance.

Text Style and Size

Structure Plans shall use uppercase text for call-outs, dimensioning, and labeling. The use of uppercase text makes it easier to distinguish characters within the plans. For NOTES, a combination of upper and lowercase text shall be used since this is much easier to read than all uppercase text in sentence or paragraph form.

Sheet titles in the Title Blocks and Detail Titles shall be all uppercase text, except when using abbreviations in the cases that space is limited (e.g., St, Blvd, No., etc.).

For seldom used hand-drafted sheets, vertical single stroke Gothic or Reinhardt style text shall be used. Normal lettering height shall be $\frac{5}{32}$ inches minimum; text used for Title Block and Detail Titles shall be $\frac{1}{4}$ inch height.



For more commonly used CADD drafted sheets, use 0.14 inches for normal lettering height, 0.175 inches for Detail Subtitles, and 0.24 inches for Title Blocks and Detail Titles. Sheet Titles shall be 0.24 inches lettering height, font style BOLD43, and Weight 0. Refer to Figure 1.1.1 and the *CADD User's Manual: 2.6 Text*, for more information regarding text size, fonts, and weights.

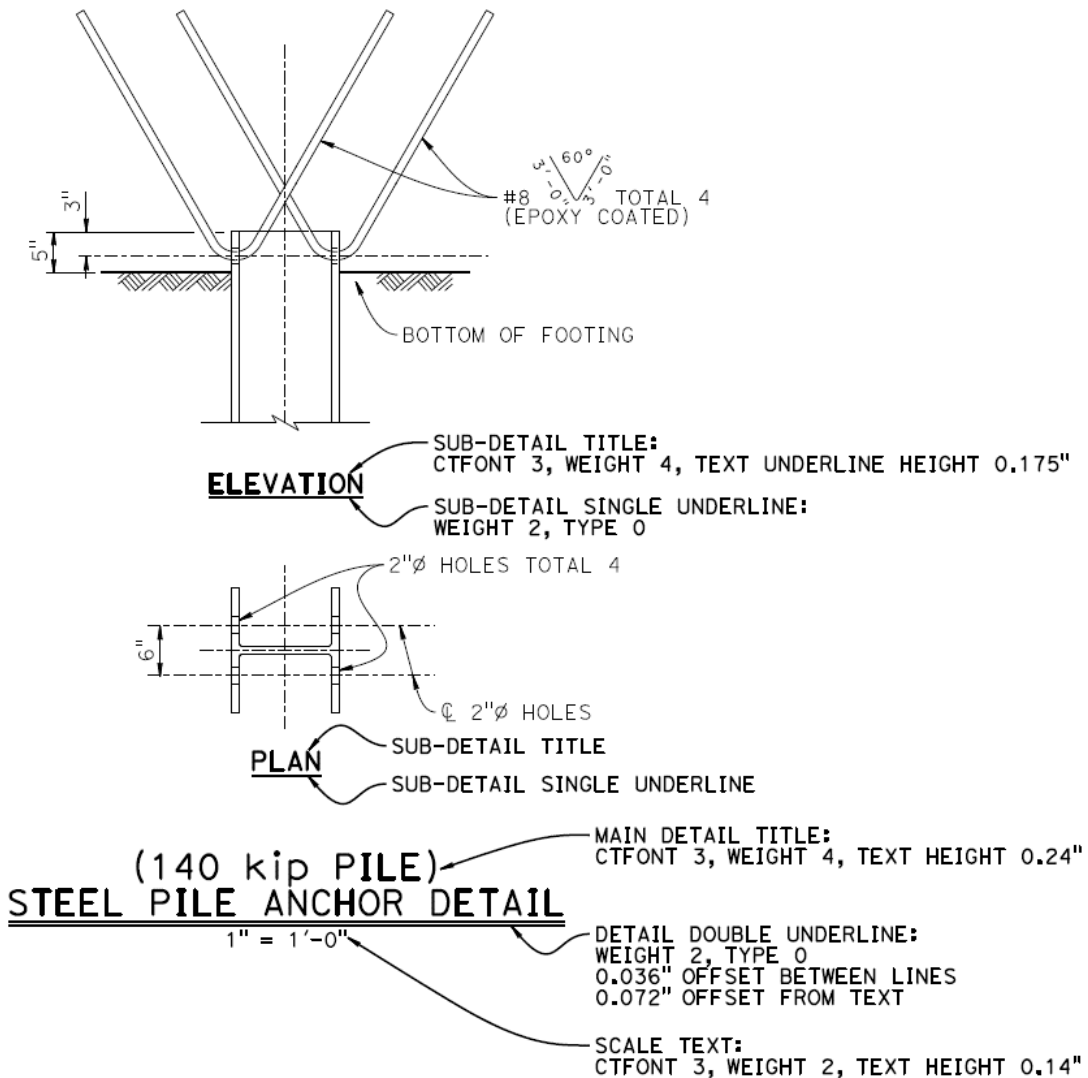

Figure 1.1.1 Text style, size and detail titles



Detail Titles and Sheet Call-outs

Notes and Titles referring to specific Detail(s) shall show the exact Detail Title in all uppercase text with quotation marks:

Examples: “SECTION C-C”
“TYPICAL SECTION”

Notes calling out details or notes found on a different sheet shall show the exact Detail and Sheet Names in all uppercase text with quotation marks:

Examples: See “SECTION C-C” on “ABUTMENT DETAILS No. 2” sheet.
For location of “SECTION A-A” and “SECTION B-B”, see
“BENT LAYOUT” sheet.

Notes calling out details found on multiple sheets shall show all the exact Sheet Names in all uppercase text with quotation marks:

Examples: For locations of “SECTION C-C,” see “ABUTMENT 1 LAYOUT” and
“ABUTMENT 2 LAYOUT” sheets.

Detail Layout, Sections, and Views

The following rules provide guidance on the proper layout of details within a set of plans. They are meant to establish a standard to be used for all details to allow easy reading of the plans.

- Stationing for a PLAN view is normally left to right.
- TYPICAL SECTION and other SECTION views show further details for a typical bridge component at a given location. TYPICAL SECTIONS are used to depict standard elements for the abutments, bents, retaining walls, etc. On sheets other than the GENERAL PLAN, it is preferred to show lettered sections which show the location and orientation of the SECTION.
- As additional SECTIONS are needed, define them with a lettered SECTION (e.g., SECTION A-A, SECTION B-B, etc.). Letters used for SECTIONS may repeat for each different bridge element within a set of plans. Avoid the use of double lettered SECTIONS (e.g. SECTION AA-AA).
- Do not associate SECTIONS to the component(s) they are detailing (e.g. ABUTMENT SECTION A-A); instead use lettered sections (e.g. SECTION A-A) for all components.



- All SECTION views shall be taken from a PLAN, ELEVATION, or other VIEW. Do not take a SECTION from another SECTION.
- A SECTION view shall show all intersecting lines that intersect the SECTION cut plane, whereas a VIEW is a projection. Unlike a VIEW, do not show hidden lines, reinforcement, or other items beyond the cut plane in a SECTION. For an example of a SECTION view, see Figure 1.1.2.

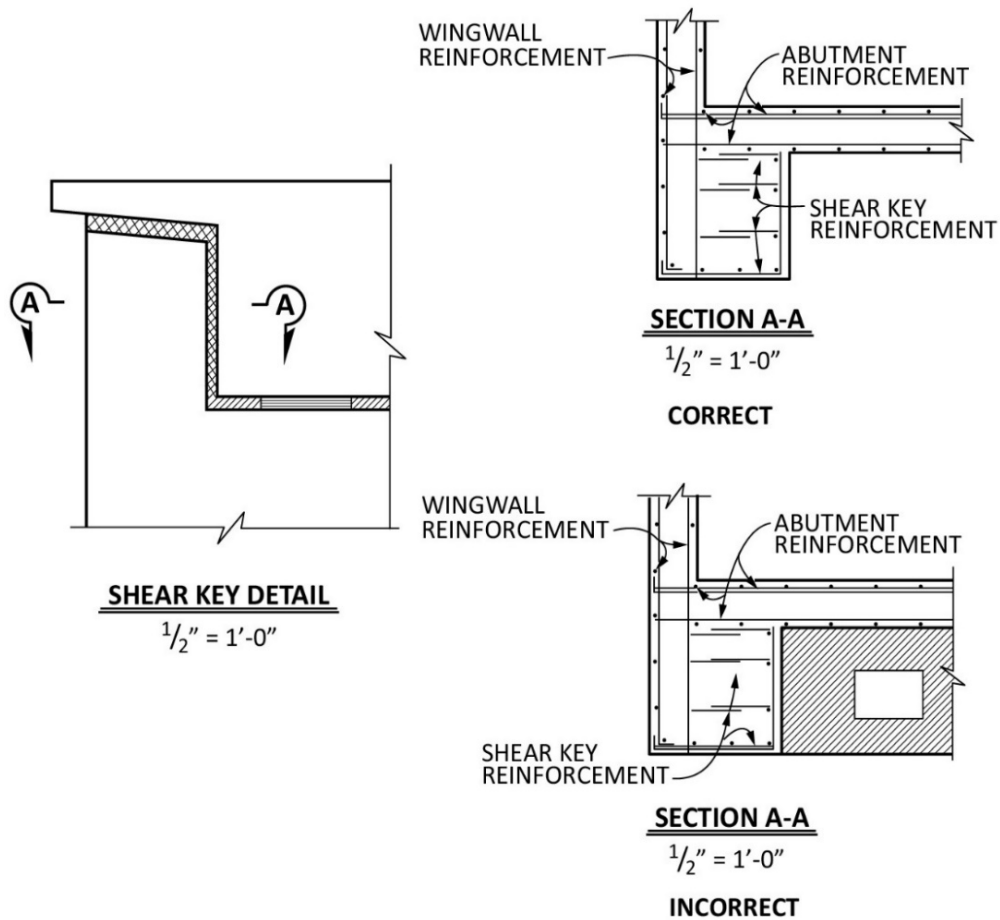

Figure 1.1.2 Section view



Elevation Views

ELEVATION views are usually projected from the right edge of the deck, face of the wall shown, or lower side of the structure shown in the PLAN view. The ELEVATION view may be mirrored, developed, or taken at a specific location as a VIEW.

When the work being done is only on the upper side of the PLAN view for a project such as a widening, barrier rail replacement, or retaining wall in roadway fills, a MIRRORED ELEVATION shall be used. In addition, MIRRORED ELEVATION should be used for retaining walls which are placed in roadway cuts, along the bottom of the PLAN view. The MIRRORED ELEVATION is the view as if reflected in a mirror, with the stationing shown from left to right.

A DEVELOPED ELEVATION is used when the radius or bend of a structure is such that a projected elevation would not show an accurate view of the structure. The DEVELOPED ELEVATION shows the true length of the structure as though it were on a straight line. Use a DEVELOPED ELEVATION view for Pedestrian Overcrossing (POC) structures, bridges, and retaining walls that are not straight.

For curved structures in which work is done on the upper side of the PLAN view, this elevation view shall be titled "DEVELOPED MIRRORED ELEVATION." This may also be used for retaining walls which are placed in roadway cuts, along the bottom of the PLAN view.

Scale Format

There are two types of scales used on Structure Plans, Architect and Engineer. These scales shall be expressed in the following formats:

- Architect scales are commonly used for DETAILS, SECTIONS, and VIEWS.

Example: $\frac{3}{4}'' = 1'-0''$

- Engineer scales are commonly used for PLAN and ELEVATION views.

Example: $1'' = 10'$

Dimensioning and Notations

- Lengths and distances are given in feet, inches, and fractions of an inch:

Example: 279'-3½" MEASURED ALONG RWLOL



- Where a dimension is one foot or greater, place a hyphen between the foot and inch values:
Examples: 1'-0", 2'-3", or 1'- 0½"
- Where a dimension is less than one foot, do not use the foot designation or hyphen in advance of the inch value:
Example: 6" not 0'-6"
- Where a dimension is less than one inch, do not add zero in advance of the fraction:
Example: ½" not 0'-½"
- Spacing between girders or pile spacing is given in feet and inches:
Example: 4 SPACES @ 6'-0" = 24'-0"
- Elevations for DATUM and structure benchmarks are given in decimal feet, without the foot symbol, rounded to the hundredths of a foot:
Examples: BB Elev = 330.00 or DATUM Elev = 200.00
- Elevations given for piles, footings, and other foundation work are shown to a tenth of a foot; this includes the bottom of footing elevations shown on FOUNDATION PLANS:
Example: 330.1
- Spacing of reinforcement is given in inches, without the inches symbol, and is always assumed in inches unless otherwise shown:
Example: #5 @ 18 (#5 bars spaced at 18 inches apart)
- Length of reinforcement is given and separated by lower-case "x" when applicable:
Examples: #5 x 6'-0" @ 12 (6'-0" long #5 bars spaced 12 inches apart)
#5 x 5'-0", Tot 4 (total of four 5'-0" long #5 bars)
- Dimension call outs shall NOT be "ASSOCIATED" with any details within a CADD file used to detail a set of structure plans; instead dimensions should be "DROPPED" or edited using the text edit tools to "LOCK IN" the values. This prevents dimensions from changing if scales are changed.
- Angles for bearings are given in degrees, minutes and seconds; bearings are rounded to the nearest second. Minutes and seconds are given in two-digit values.
Examples: 9°05'09"
30°15'38"



It is preferred that all text read horizontal from the bottom of the sheet and in the same direction; vertical text should read from the right side of the sheet. Mixing the orientation of dimensions and text on a given sheet and using circular dimensional text (shown below) should be avoided.

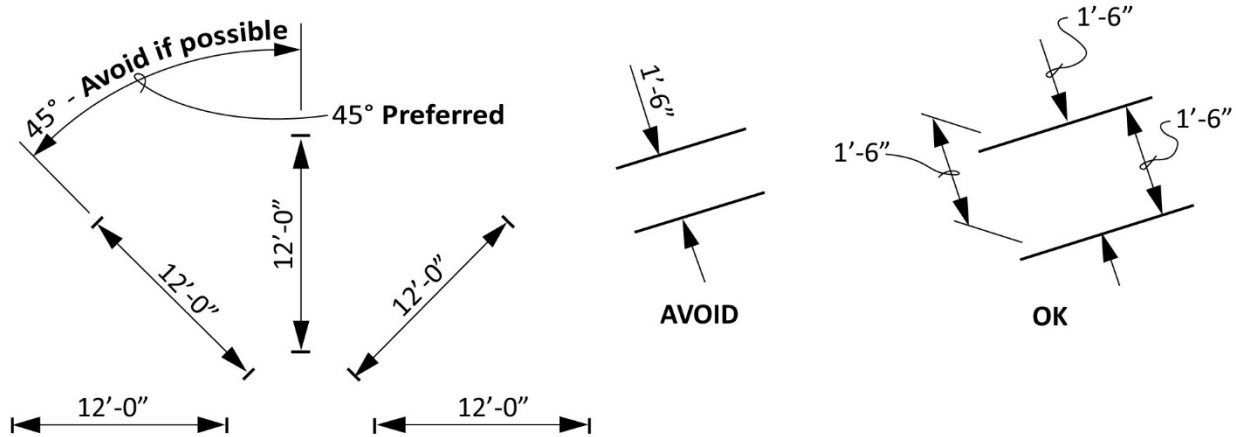

Figure 1.1.3 Orientation of dimensions

Radius call outs shall point to the inside of the curve. Text may be placed off the curve on small radii, but the leader arrow shall always point to the inside of the curve.

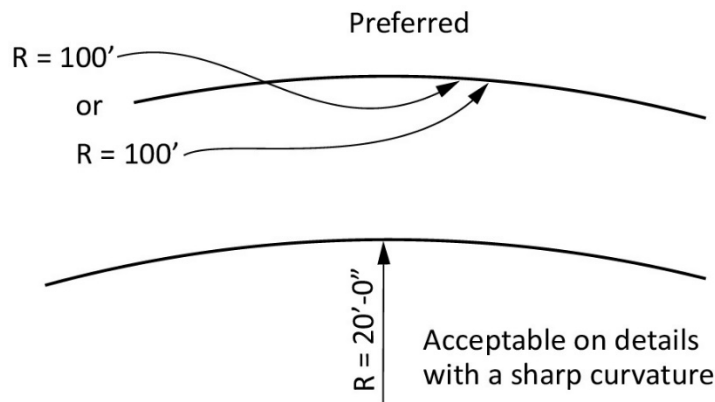

Figure 1.1.4 Radii designation



The default clearance specified in the *Standard Specifications* is 2 inches; therefore all 2-inch clearance locations shall not be shown on plans

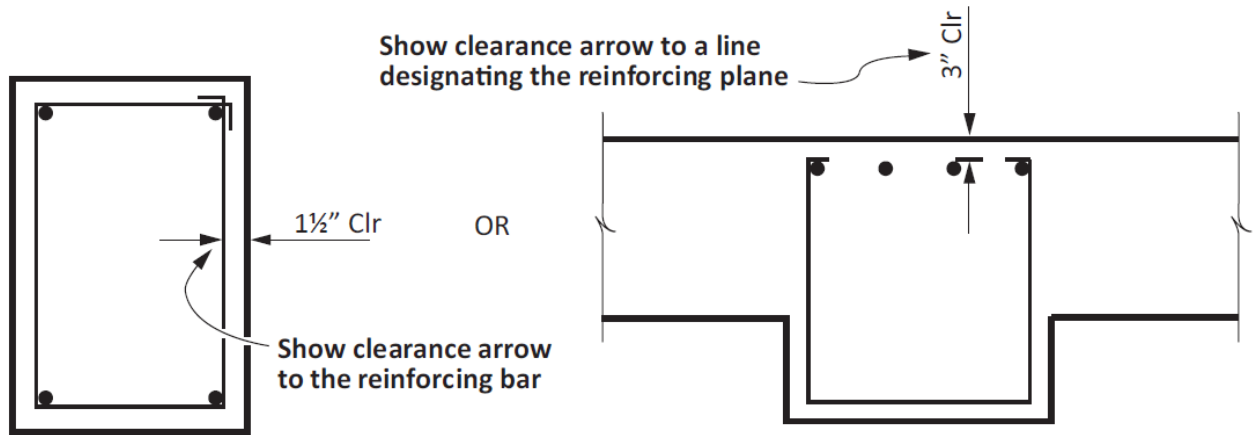

Figure 1.1.5 Reinforcing clearance dimension

It is generally clearer to show reinforcing in a SECTION view, rather than in an ELEVATION view. The total number of bars (e.g., #11 Tot 14) shall only be called out if you can count every bar in the SECTION.

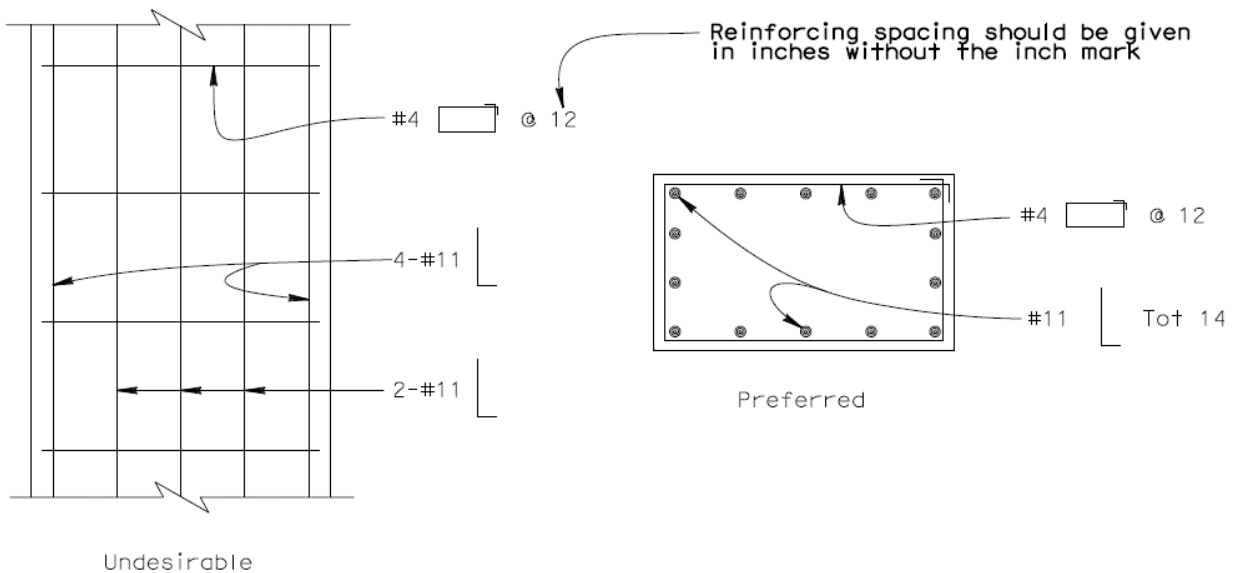

Figure 1.1.6 Reinforcement in vertical and horizontal planes



There are several ways to show multiple layers of reinforcement, including staggered and alternating layers.

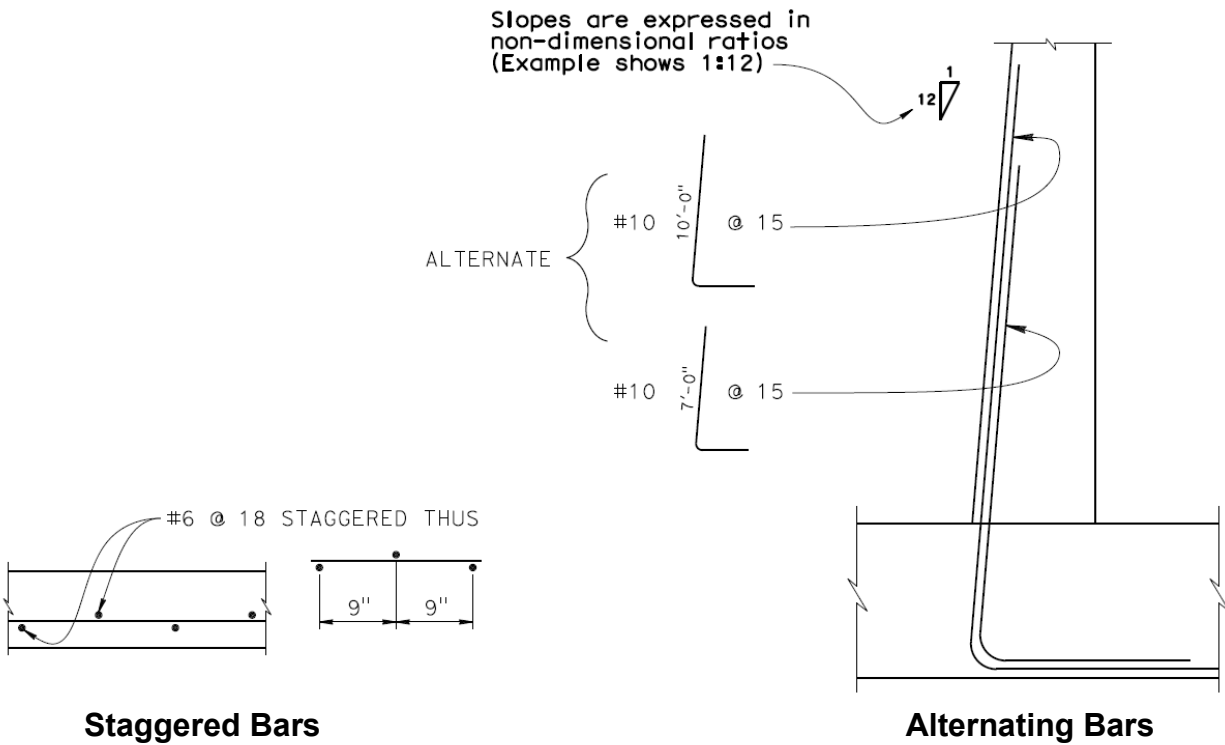

Figure 1.1.7 Staggered and alternate bars

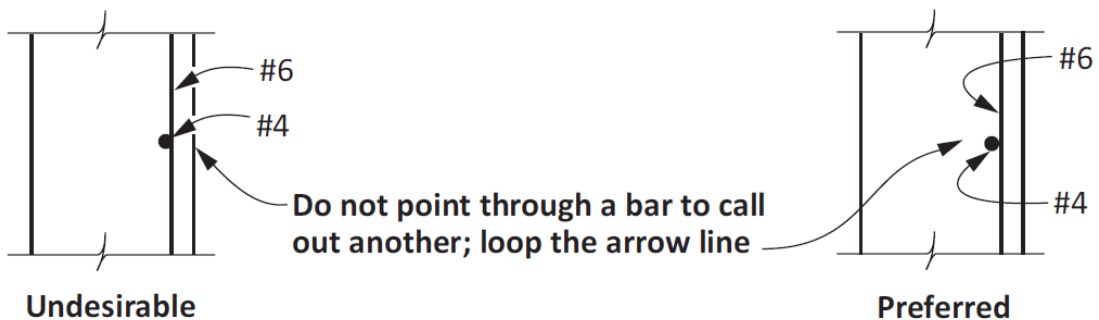

Figure 1.1.8 Multiple layers of reinforcement

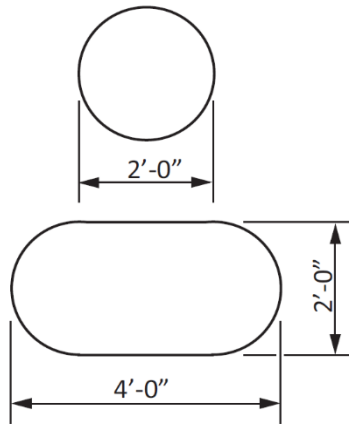

Figure 1.1.9 Circular sections

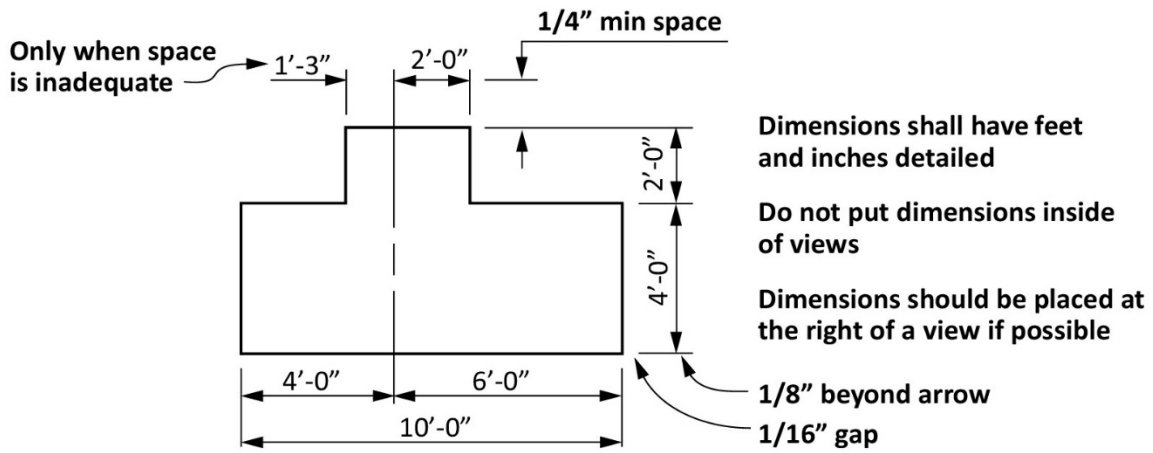
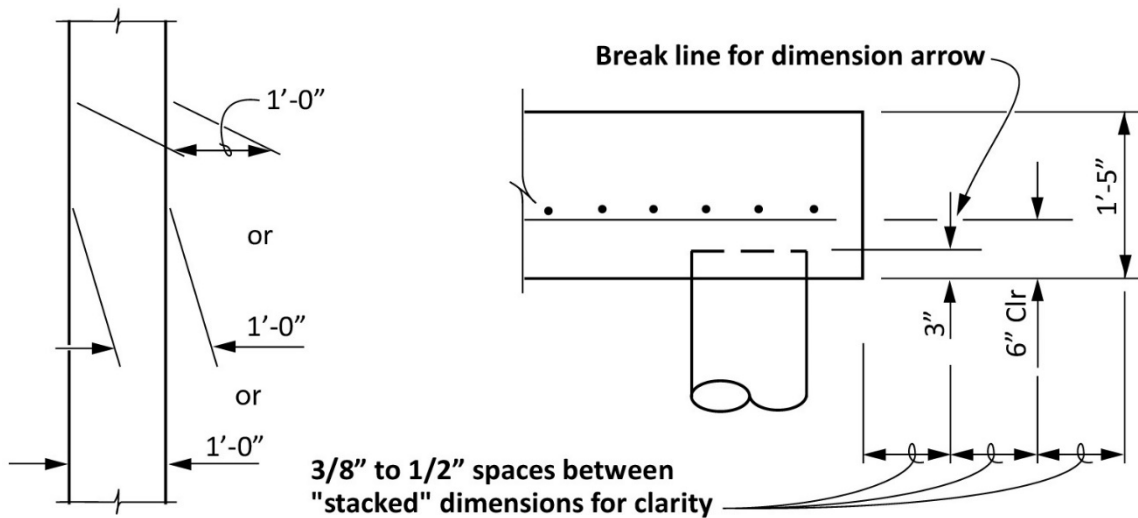
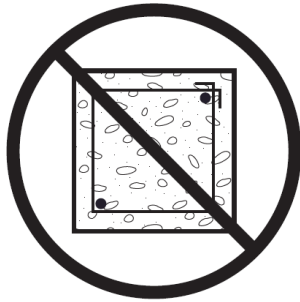

Figure 1.1.10 Rectangular views

Section Hatching



Do not show the sand and aggregate in any concrete section.



Section of timber or lumber

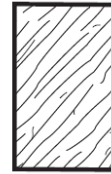

End view of timber or lumber

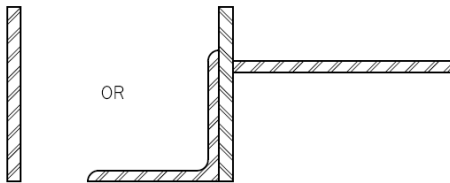

Cross hatch steel in large scale ($\frac{1}{2}'' = 1'-0''$ or greater) when two or more pieces are shown. Hatch alternate direction on pieces to clearly define limits.

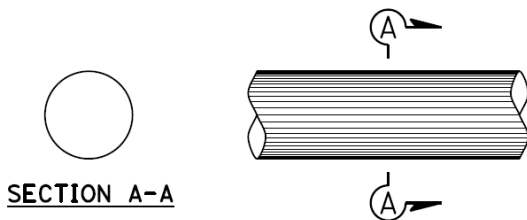

Avoid shading lines on rounded or sloping surfaces. When needed to clarify detail, space the shading lines a minimum of 0.0625 inches apart.

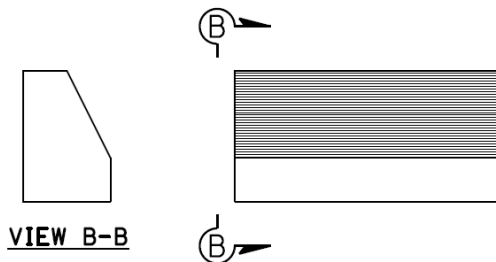

A SECTION or VIEW defines the shape more clearly than shading.

Figure 1.1.11 Section hatching



Notes and Legend

- NOTES and LEGEND titles shall be capitalized.
- Use a colon and DO NOT underline NOTES and LEGEND titles.
- Use upper and lowercase text for NOTES and LEGEND.
- DO NOT identify NEW CONSTRUCTION in LEGEND or elsewhere in plans.
- Use the same standard line type for existing structures above and below grade.
- The LEGEND shall provide symbols used to describe the items on a sheet. DO NOT include symbols that are in the Standard Plans (A10A through A10E) in LEGEND.

Example:

LEGEND:



	Existing Structure
	Concrete Removal
	Minimum Vertical Clearance

Figure 1.1.12 Example of Legend

- As a rule, placing a NOTE on a sheet can provide information relative to an entire sheet, or it can reference a location that provides more information for a specific detail elsewhere in the plans.
- NOTES that are given in complete sentences or statements shall end with a period.
- The use of extensive callouts should be avoided. Examples of when callouts are needed include existing bridge strengthening or retrofit projects, where locations of work should be clearly identified. Statements for locations of work do not always require punctuation.
- Do not use lettered callouts to avoid conflicts with other Standard Plan notations. All NOTES or callouts shall be denoted with either 1, 2, 3...or ①, ②, ③...
- NOTES shall be placed above callouts when listed together.

Example:

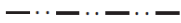
Notes	NOTES:
	1. For "PILE DATA TABLE", see "INDEX TO PLANS" sheet.
	2. For details not shown, see "BENT DETAILS No. 1" sheet.
Call-outs	3. For MGS, see ROADWAY PLANS.
	① Paint "XYZ AVENUE OC BRIDGE No. XX-XXXX" Year Constructed
	② Paint Bent Number
	③ Retrofit hinge with pipe seat extenders and cable restrainers

Figure 1.1.13 Example of Notes and Callouts



Structures North Arrow

A Structures North Arrow shall be placed on all PLAN views within a set of Structure Plans to identify the orientation of the PLAN view. The bottom of the arrow width shall be $\frac{3}{8}$ " wide and height $\frac{9}{16}$ " tall on reduced plans. On full size plans these dimensions shall be $\frac{3}{4}$ " x $1\frac{1}{8}$ " respectively.

Example:

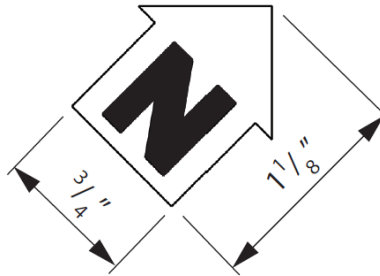

Figure 1.1.14 Standard structure detailing cell (North Arrow)

Existing Structures

The standard structure detailing cell shown below shall be placed in the lower left-hand corner of the GENERAL PLAN sheet and in the same location on any other sheet when new work is dependent on existing dimensions:

NOTE:
THE CONTRACTOR SHALL VERIFY ALL
CONTROLLING FIELD DIMENSIONS
BEFORE ORDERING OR FABRICATING
ANY MATERIAL.

Figure 1.1.15 Standard structure detailing cell (Existing Dimensions)

For example, when dimensioning a TYPICAL SECTION for a widening project, the overall roadway width is set by the Roadway Designer, while the existing roadway or structure dimensions is shown with a "±" and taken from AS-BUILT plans. Since the widening width is based on the actual dimension of the existing structure, it also warrants a "±"; however, the final dimension does not require a "±" because the overall widened width of the bridge is shown by dimensioning the new edge of deck from a new station line.

Dimensions including existing radii, bearing, or elevations on an existing structure shall always include a "±" to indicate that they are approximate. The dependent dimensions shown on the plans must be accurate enough to enable quantity calculations. The dimensions shown shall reflect the accuracy to which the dimensions of the existing structure are known, and contractors should not be required to field verify dimensions to prepare their bids.



Advanced Planning Study

At the request of the District, an Advance Planning Study (APS) is prepared by Structure Design. An APS shall be delivered on an 11 x 17 sheet with true scale shown. The scales and details shown on the APS shall assume to be full size on 11 x 17 sheet. See *Memo to Designers: 1-8 Planning Studies*, and *Bridge Design Details 1.1: Advance Planning Study Detailing Examples Attachments 1A.B.1 through 1A.B.6* for more information and examples.

As a project goes through the APS (K or O) phase, it is given a “Project EA” (e.g. 0A020). The phase associated with an APS will be either “K” or “O”. When the project goes to the design phase (1), the “Project EA” changes to the “Contract Number” (e.g. 01-0A0204).

Structure Plan Sheet Order

Except for the GENERAL PLAN, FOUNDATION PLAN(s), BRIDGE STANDARD DETAIL SHEETS (XS SHEETS), and LOG OF TEST BORING(s) all Structure Plans shall use a structure detail border. Do not use periods or parenthesis after sheet numbers in the INDEX TO PLANS.

Structure Plan sheets shall be placed in the following order:

SHEET No.	TITLE
1	GENERAL PLAN*
2	INDEX TO PLANS**
3	STAGE CONSTRUCTION***
4	STRUCTURE PLAN No. 1, 2, 3...****
5	DECK CONTOURS
6	FOUNDATION PLAN
7	ABUTMENT LAYOUTS
8	ABUTMENT DETAILS
9	BENT LAYOUT
10	BENT DETAILS
11	TYPICAL SECTION
12	GIRDER LAYOUT*****
13	GIRDER REINFORCEMENT
14	BRIDGE STANDARD DETAIL SHEETS (XS SHEETS)
15	LOG OF TEST BORING



- * The GENERAL PLAN sheet typically shows a PLAN, ELEVATION, TYPICAL SECTION, and PROFILE GRADE for any given structure. No more than one GENERAL PLAN shall be used for a single structure. For long structures it may be necessary to add STRUCTURE PLAN sheets that show PLAN and ELEVATION, using as many sheets as necessary with a minimum scale of 1' = 20'.

A clear space shall be left on the GENERAL PLAN for the quantities decal that will be provided by the Structure Cost Estimating Branch. Quantity decals are typically 4" wide and 3" to 5" tall. Each quantity listed shall be given on one line. If the quantities decal cannot fit on the GENERAL PLAN sheet, it may be placed on another sheet near the front of the set of plans. If an INDEX TO PLANS sheet is used, this is the preferred alternate location. If the quantities decal is not on the GENERAL PLAN, place a note on the GENERAL PLAN referencing the location of the quantities decal.

- ** The INDEX TO PLANS sheet shall only be used if the INDEX TO PLANS will not fit on the GENERAL PLAN sheet. The INDEX TO PLANS shall show the exact name of each sheet in uppercase letters. The preferred location for the INDEX TO PLANS is on the GENERAL PLAN, otherwise an INDEX TO PLANS sheet may include the INDEX TO PLANS, GENERAL NOTES, PILE DATA TABLE, CONCRETE STRENGTH AND TYPE LIMITS diagram, and other information, as required. In some cases, there is only one sheet in a set of plans, in that case no INDEX TO PLANS is listed on the GENERAL PLAN.

- *** STAGE CONSTRUCTION sheet shall be used when multiple stage construction details cannot fit on the GENERAL PLAN. Separating the staging details will allow for additional information to be shown and provide clarity. If a STAGE CONSTRUCTION sheet is used, information shall not be duplicated on TYPICAL SECTION shown on GENERAL PLAN.

- **** STRUCTURE PLAN sheet(s) shall be used for large structures when the scale shown on the GENERAL PLAN sheet is too small to provide adequate details. When STRUCTURE PLAN sheets are used, the GENERAL PLAN sheet can be simplified with the PLAN, ELEVATION, and PROFILE GRADE shown at a scale that displays the entire structure.

The preferred location for the TYPICAL SECTION is on the GENERAL PLAN sheet; however, the TYPICAL SECTION may be shown on STRUCTURE PLAN sheets when appropriate. An exception to this is when there are ramps, or the structure width varies substantially enough that they are better displayed on a separate sheet.



In some cases, a STRUCTURE PLAN sheet for a retaining wall will not have a PLAN view; in this case, the ELEVATION view shall show all details including the spacing of ground anchors and piles.

***** CAMBER diagram/notes and PRESTRESSING NOTES shall be placed on the GIRDER LAYOUT sheet. If the detail or notes cannot fit on the GIRDER LAYOUT sheet, they should be placed on the GIRDER REINFORCEMENT or GIRDER DETAILS sheets.

Additional Structure Plan detail sheets and insertable *Bridge Standard Detail Sheets* (XS Sheets) are placed before the LOG OF TEST BORING sheet(s). See *Bridge Design Details: 1.6 Use of Bridge Standard Detail Sheets (XS Sheets)*, for more information.

Overcrowding plan sheets shall be avoided. If additional sheets are needed for bridge components, number them sequentially.

Examples: ABUTMENT DETAILS No. 1
ABUTMENT DETAILS No. 2...

Avoid using the phrases "To be approved by the Engineer" or "as directed by the Engineer". If you must use these or similar phrases, discuss it with the Structure Specifications Branch or your Branch Chief.

Use ROADWAY PLANS when referring to the District portion of Project Plans within a set of Structure Plans. Do not use quotation marks.

Examples: Approx FG, SEE ROADWAY PLANS

NOTE:

1. For proposed utility layout details, see ROADWAY PLANS.