



Multi Benefit Treatment BMP Trash Full Capture Requirements – Design Guidance

October 2018

California Department of Transportation
HQ Division of Design

Caltrans Supplemental Multi Benefit Treatment BMP Design Guidance

Certified Multi Benefit Treatment BMPs for Trash

Full Capture System Requirements Technical Guidance

Supplemental: To the Caltrans Treatment BMP Design Guidance for demonstrating trash removal full capture certification.

Table of Contents

1. Background.....	1-1
2. SWRCB Criteria for Full Capture (SWRCB Fact Sheet)	2-1
3. Gross Solids Removal Devices (GSRD).....	3-1
4. Design Procedures for Multi Benefit TBMP(SWRCB Fact Sheet).....	4-1
5. Certification Method Volume (SWRCB Trash Policy and Fact Sheet).....	5-1
5.1 Volumetric Runoff Coefficient for Calculating Water Quality Volume (Caltrans PPDG)	5-1
6. Caltrans Approved Treatment BMP Plans, Specifications, and Guidance	6-1
6.1 Supplemental details Plans	6-1
6.2 Specifications.....	6-1
7. Example Multi Benefit BMP Volumetric Certification.....	7-1
7.1 Calculate the full capture volume	7-1
8. Flow Based BMP Certification Design Method	8-1
8.1 Calculate the peak flow	8-1
8.2 Calculate the flow through the Multi Benefit treatment BMP	8-1
8.3 Flow through Media.....	8-2
8.4 Flow through trash screen.....	8-2
8.5 Orifice flow perforated riser	8-3
8.6 Example Flow	8-3
8.7 Flow through media.....	8-4
8.8 Example Flow through the Trash Intercept Screen.....	8-4
9. Unit Hydrograph Methods	9-1
10. Continuous Simulation Methods	10-1
Appendix A: Plans.....	A-1
Appendix B: Orifice Flow Reference.....	B-1

List of Tables

Table 3-1. Caltrans Approved Treatment Devices Certified as Multi Benefit Full Capture	3-1
Table 5-1. Volumetric Runoff Coefficients	5-2



Section 1

Background

Caltrans received a California Water Code 13383 letter requiring the development of a plan to comply with the statewide trash requirements as part of the Caltrans statewide NPDES permit. The letter states, “The Trash Provisions require the Department to comply with the prohibition of discharge by installing, operating, and maintaining any combination of full capture systems,* multi-benefit projects,* other treatment controls,* and/or institutional controls* for all storm drains that captures trash from significant trash generating areas.*”. This allows flexibility in compliance, with a combination of full capture, multi benefit, other treatment controls, and institutional controls. All permittees received letters in this regard, so the majority of trash BMPs currently being installed are for municipalities with a variety of land uses. Caltrans has unique safety requirements for the operation and maintenance of our highway and road way facilities. Many municipal solutions are not appropriate for highway applications, due to the inherent safety requirements for highways and freeways.

The letter highlights the development of a trash plans for NPDES permit compliance for each agency; the plans must include trash assessment, a feasibility study of appropriate BMPs, life cycle costs comparisons, pollutant removal effectiveness monitoring of BMPs, drainage design criteria, and operations and maintenance with safety considerations to FHWA standards. Fortunately, Caltrans has an extensive library of research already conducted on storm water treatment BMPs including trash full capture devices pilot tested for highway applications. With this vast data pool, BMP guidance can be implemented now that complies with the permit and is appropriate for our facilities. The conclusions of many trash pilot studies state that institutional controls and end of pipe treatment are usually more cost effective and feasible due to safety concerns to the public.

The department conducted extensive pilot testing of full capture trash removal devices to comply with the Los Angeles trash TMDL, these studies developed into specifications, plans, and design guidance. The LA regional board developed the concept and criteria of “full capture trash devices” and this has been adopted by the SWRCB for a statewide trash plan. Caltrans conducted concurrent pilot testing of other Treatment BMPs and pollutants (2004 CT Pilot retrofit studies CTSW-RT-01-050), which was used to create an approved list of treatment BMPs. Caltrans reviewed many TBMP in its pilot studies and New Technology reports CT-RT-09-239-06, CTSW-RT-08-167.02.02, and CTSW-RT-01-050, which includes many trash BMPs. These studies should be reviewed prior to proposing non-approved TBMPs for highway use, and address any issues or additional research needed from previous conclusions, so we are building on this knowledge base. This can be accomplished through pilot testing in accordance with our NPDES permit and SWMP. Based on the previous research, Caltrans is highlighting the GSRD and multi-benefit BMPs as appropriate treatment BMPs for use now as the data and analysis conclude they are effective and feasible for highway facilities.

The SWRCB developed a trash implementation webpage with supporting documents to clarify the many options to comply; these documents can be found at the link provided, including the fact sheet for multi benefit trash full compliance TBMPs. Following the SWRCB fact sheet the Caltrans list of approved BMPs can be used now to meet the SWRCB Multi benefit Statewide Trash Policy Certification requirements. If a project engineer can demonstrate the site design

meets the criteria set in the SWRCB fact sheet, they are certified by SWRCB E.O. as trash full capture. SWRCB fact sheet and links to individual BMP types attached. Caltrans has selected the SWRCB track 2 option under the statewide trash plan. This allows: full capture TBMPs, partial capture TBMPs, full capture equivalent treatment, and other institutional controls. Based on this Caltrans designers should continue to follow our list of approved treatment BMPs as first options for compliance as they are based on the best available science and are considered to meet Maximum Extent Practicable (MEP) criteria in compliance with the SWMP, Clean Water Act and NPDES permit.

[Storm Water Program - Trash Implementation Program](#)

Section 2

SWRCB Criteria for Full Capture (SWRCB Fact Sheet)

1. Trap all particles that are 5 mm or greater up to the region-specific design flow or corresponding volume; (see NOAA atlas 14 online maps for one hour one year, for depth or intensity). [NOAA Atlas 14 Point Precipitation Frequency Estimates](#)
2. Complies with one of the following treatment designs applicable to the multi-benefit treatment system:
 - a. Flow-based design that includes:
 - 1) A trash treatment capacity equal to or greater than the peak runoff flow collected during the region specific one-year, one-hour storm event from the applicable drainage area, or
 - 2) A trash treatment capacity equal to or greater than the corresponding flow capacity; or
 - b. Volume-based design that includes a trash treatment capacity that is:
 - 1) Equal to or greater than the volumetric sizing criteria for treatment systems in the applicable State or Regional Water Board storm water permit, and
 - 2) Equal or greater than the volume generated from a one-year, one-hour storm event.
3. Incorporates an operation and maintenance plan sufficient to ensure that the captured trash does not migrate from the site; and
4. Is constructed per design plans that are stamped by a registered California licensed professional civil engineer (see Bus. & Prof. Code section 6700, et seq.).

Section 3

Gross Solids Removal Devices (GSRD)

Gross Solids Removal Devices (GSRD) have been certified by the LA regional board executive officer as full capture for the design criteria for the LA TMDL (basis for full capture design criteria for state trash plan), but are not currently listed on the state water board webpage. Being listed on the state water board webpage is not required for designers to use them for compliance because Caltrans follows trash plan track 2, so the TBMPs only need to demonstrate they meet the design criteria (fact sheet) and show they are effective for trash removal. This was done during pilot studies, by submitting the pilot studies to the SWRCB and LARWQCB, and approval of SWMP. Therefore, they can be used now for the trash plan compliance. In addition to the GSRD, Caltrans has guidance for TBMPs that the LARWQCB has reviewed and determined to be effective for trash removal as multi benefit full capture certified.

[Treatment BMP Design Guidance](#)

Table 3-1. Caltrans Approved Treatment Devices Certified as Multi Benefit Full Capture

Treatment Devices
Bio-retention ^a
Detention Basin ^a
Infiltration Trench ^a
Infiltration Basin ^a
Austin Media Filter Earthen ^a
Austin Media Filter Concrete ^a
Delaware Media Filter ^a

a. *The Multi-benefit Treatment Systems are certified by the state water board Executive Director (fact sheet).*

Section 4

Design Procedures for Multi Benefit TBMP(SWRCB Fact Sheet)

Designers must first follow the Caltrans NPDES permit and Design Guidance for Sizing the TBMP for the 85th percentile 24-hour storm water quality sizing event, outlined in the PPDG (PPDG section 5) and corresponding Treatment BMP design guidance's to size the water quality event based on NPDES permit requirement, as outlined in the SWMP.

[Project Planning and Design Guide](#)

Then go to the HQ design website to find the design guidance for the treatment BMP selected.

[Treatment BMP Design Guidance](#)

Other treatment BMP sizing methods for post construction may be used if approved by the regional board and state board as appropriate for the site. Volume based certification, flow based certification, hydrographs modeling the flow or volume, or continuous simulation (EPA SWMM), are all acceptable methods. The SWRCB regulations highlighted in the fact sheet allows the designer to use volume or flow based methods to demonstrate that the treatment BMP is sized for both the NPDES permit water quality sizing event and trash full capture event.

Section 5

Certification Method Volume (SWRCB Trash Policy and Fact Sheet)

5.1 Volumetric Runoff Coefficient for Calculating Water Quality Volume (Caltrans PPDG)

For volumetric BMP sizing, the following equation from the Small Storm Hydrology Method (SSHM) should be used, as it takes into account the smaller depth of the Water Quality event. This will replace the use of rational method C (runoff coefficient) values for the calculation of WQV.

$$V_R = R_v(P/12)A$$

Where:

V_R = Runoff volume (ft³)

R_v = Volumetric Runoff Coefficient (unitless)

P = Precipitation Depth (in) – from NOAA Atlas 14

A = Contributing Drainage Area (ft²)

The SSHM is recommended for stormwater design to calculate the volumetric sizing of stormwater BMPs because it was developed specifically for this purpose and it has been adopted by many municipalities and CASQA. For Caltrans implementation, a table of R_v values which represent a mix of both impervious and pervious areas is provided (see Table 5-1) and scenarios that are appropriate for highway use are identified. The highway design scenarios we expect designers to encounter and ways to calculate the water quality volume ($WQV = V_R$) are presented below:

1. For areas with over 50% impervious surfaces and that drain the impervious area to pervious area, use Table 5-1 based on the percent impervious of the site or use the Urbonas equation which is a single calculation for the entire drainage area using a composite R_v

$$V_R = R_v(P/12)A, \text{ where } V_R \text{ is the WQV of the entire drainage area.}$$

For the next geometric drainage scenarios, a composite V_R (WQV) calculation is required, where $WQV = V_{R1}$ (WQV impervious) + V_{R2} (WQV pervious) is calculated for the total WQV for the site.

$$V_{R1} = R_{v1}(P/12)A_1 \quad V_{R2} = R_{v2}(P/12)A_2 \quad V_{R1} + V_{R2} = V_{R \text{ total}}$$

The R_v values for scenarios 2-4 should be taken from Table 5-1 for both impervious and pervious areas. For pervious areas determine the soil type and take a weighted average of the R_v appropriate for the site condition.

2. For projects that are designed with hydraulically separated pervious and impervious areas, determine separate R_v values, calculate separate WQVs for impervious and pervious drainage areas, and then combine for total WQV.
3. For projects where the impervious surfaces are less than 50% of the drainage area of the site, determine separate R_v values, calculate separate WQVs for pervious and impervious areas, and then combine for total WQV.
4. For projects where pervious areas drain to impervious areas, determine separate R_v values, calculate separate WQVs for pervious and impervious areas, and then combine for total WQV.

Table 5-1. Volumetric Runoff Coefficients

Description	Volumetric Runoff Coefficient (R_v)	Source
100% Impervious	0.89	Urbonas 1999
90% Impervious	0.73	Urbonas 1999
80% Impervious	0.60	Urbonas 1999
70% Impervious	0.49	Urbonas 1999
60% Impervious	0.41	Urbonas 1999
50% Impervious	0.34	Urbonas 1999
Clayey Soils ^a	0.22	Burton and Pitt 2002
Sandy Soils ^a	0.03	Burton and Pitt 2002

a. Value for an average California 85th percentile, 24-hour storm event depth of 1.26 inches.

The SSHM volumetric runoff coefficients shown in the table above are from *Caltrans Technical White Paper: Runoff Coefficient Evaluation for Volumetric BMP Sizing*, dated May 29, 2015. The white paper can be found at: <http://design.onramp.dot.ca.gov/storm-water-guidance>

Use NOAA Atlas 14 to determine the volumetric storm depth for 1-year 1 hour storm event.

The region specific one-year , one-hour storm (depth) may be obtained from the National Oceanic and Atmospheric Administration Atlas 14 Point Precipitation Frequency Estimates at [NOAA Atlas 14 Point Precipitation Frequency Estimates](#)

5.1.1 Calculate the volume

1. Measure the drainage area (ft^2),
2. Determine the 1-year 1-hour storm depth (P in),
3. Determine the volumetric runoff coefficient R_v .

$$\text{Full Capture Volume (FCV)} = R_v (P/12) \times \text{Area}$$

Compare the Water Quality Volume (PPDG method section 5) with the full capture volume. If the 85th percentile 24-hour volume is greater than the capture of the 1-year 1- hour volume, the BMP is full capture per SWRCB fact sheet requirements.

Note: A trash rack is still recommended to prevent trash from scouring out during larger flood events.

Section 6

Caltrans Approved Treatment BMP Plans, Specifications, and Guidance

The approved treatment BMPs have approved XS plan sheets.

<https://design.onramp.dot.ca.gov/node/1674>

Media filter overflow ¼ screen (5mm) can be found on sheet WD-XX, trash screen overflow detail. Sheets are shown in the appendix and can be found online.

6.1 Supplemental details Plans

Caltrans has developed supplemental details which can be used for TBMPs with risers, detention basin, infiltration basins, media filters, or could be used for bio-retention overflow risers.

6.2 Specifications

Caltrans BMP guidance includes instructions on how to use standard specifications to itemize the treatment BMPs, as well as items. These are also at the link above.

For specialized TBMP designs HQ Office of Hydraulics and Stormwater Design provides design support, recommendations, and review of Non-Standard Special Provisions to accommodate innovative designs for alternatives to the approved TBMP XS sheets and guidance.

Section 7

Example Multi Benefit BMP Volumetric Certification

The volumetric comparison of the NPDES permit water quality event volume and the volume of the full capture criteria, is a straight forward calculation and comparison of volumes. This example will evaluate a multi benefit BMP in Oakland California, located on I-880, with 1 acre of drainage to a Caltrans approved Austin Media Filter.

Following the Caltrans Treatment BMP design guidance and size the BMP for the 85th percentile 24-hour water quality design event, determine the drainage area and then follow basin sizer example PPDG (page 5-9).

Basin Sizer for Oakland NWS station for 85th percentile 24-hour storm event depth = **.78 in.**

<https://env.onramp.dot.ca.gov/sw/basin-sizer>

Calculate using the SSHM method for water quality volume.

1 (acre) drainage area = 43,560 ft²

Rv = .89 for impervious area

WQV = Rv (P/12) x Area

Calculate WQV

WQV = (1 (acre) x (43560 ft²/ 1 acre) x (.78 in) x (1 ft/12in) x (.89) = **2,519.9 ft³**

7.1 Calculate the full capture volume

Determine the 1-year 1-hour storm depth

[NOAA Atlas 14 Point Precipitation Frequency Estimates](#)

Precipitation Frequency Data Server



NOAA Atlas 14, Volume 6, Version 2
 Location name: Oakland, California, USA*
 Latitude: 37.7983°, Longitude: -122.2642°
 Elevation: 31.14 ft**
 *source: ESRI Maps
 **source: USGS



POINT PRECIPITATION FREQUENCY ESTIMATES

Sanja Perica, Sarah Dietz, Sarah Heim, Lilian Hiner, Kazungu Mbatia, Deborah Martin, Sandra Pavlovic, Ingrid Roy, Carl Trappala, Dale Ulrich, Fenglin Yan, Michael Yelton, Yan Zhao, Geoffrey Bonnin, Daniel Brewer, Li-Chuan Chen, Tye Paszybok, John Yarchon

NOAA, National Weather Service, Silver Spring, Maryland

[PF tabular](#) | [PF graphical](#) | [Maps & aeriels](#)

PF tabular

PDS-based point precipitation frequency estimates with 90% confidence intervals (in inches) ¹										
Duration	Average recurrence interval (years)									
	1	2	5	10	25	50	100	200	500	1000
5-min	0.128 (0.113-0.148)	0.188 (0.147-0.193)	0.217 (0.190-0.251)	0.258 (0.222-0.299)	0.307 (0.255-0.374)	0.345 (0.270-0.431)	0.382 (0.290-0.493)	0.419 (0.317-0.560)	0.468 (0.336-0.658)	0.504 (0.347-0.741)
10-min	0.184 (0.162-0.211)	0.240 (0.211-0.276)	0.311 (0.272-0.359)	0.367 (0.318-0.428)	0.440 (0.365-0.536)	0.484 (0.399-0.618)	0.548 (0.429-0.707)	0.601 (0.454-0.803)	0.671 (0.481-0.944)	0.723 (0.497-1.06)
15-min	0.223 (0.196-0.256)	0.291 (0.255-0.334)	0.378 (0.329-0.434)	0.444 (0.384-0.518)	0.532 (0.442-0.648)	0.588 (0.483-0.748)	0.682 (0.519-0.854)	0.727 (0.549-0.971)	0.811 (0.582-1.14)	0.874 (0.601-1.28)
30-min	0.307 (0.270-0.352)	0.400 (0.352-0.461)	0.519 (0.454-0.598)	0.612 (0.530-0.713)	0.733 (0.608-0.893)	0.824 (0.665-1.03)	0.912 (0.715-1.18)	1.00 (0.757-1.34)	1.12 (0.802-1.57)	1.20 (0.826-1.77)
60-min	0.434 (0.382-0.499)	0.587 (0.498-0.692)	0.734 (0.643-0.847)	0.888 (0.750-1.01)	1.04 (0.861-1.26)	1.17 (0.942-1.48)	1.29 (1.01-1.67)	1.42 (1.07-1.89)	1.58 (1.14-2.23)	1.70 (1.17-2.50)
2-hr	0.628 (0.552-0.721)	0.818 (0.718-0.941)	1.00 (0.926-1.22)	1.25 (1.09-1.46)	1.50 (1.24-1.82)	1.68 (1.36-2.10)	1.88 (1.46-2.40)	2.04 (1.55-2.73)	2.28 (1.64-3.21)	2.48 (1.69-3.61)
3-hr	0.788 (0.691-0.902)	1.02 (0.899-1.18)	1.33 (1.16-1.53)	1.68 (1.35-1.82)	1.88 (1.56-2.28)	2.11 (1.70-2.63)	2.33 (1.83-3.01)	2.68 (1.94-3.42)	2.88 (2.05-4.03)	3.09 (2.12-4.53)
6-hr	1.11 (0.979-1.28)	1.46 (1.28-1.67)	1.89 (1.65-2.18)	2.23 (1.93-2.80)	2.67 (2.22-3.25)	3.00 (2.42-3.76)	3.33 (2.61-4.30)	3.68 (2.76-4.89)	4.08 (2.90-5.75)	4.40 (3.03-6.47)
12-hr	1.48 (1.29-1.68)	1.93 (1.69-2.22)	2.51 (2.20-2.90)	2.97 (2.57-3.46)	3.57 (2.96-4.35)	4.01 (3.24-5.02)	4.46 (3.48-5.74)	4.88 (3.69-6.53)	5.46 (3.91-7.68)	5.88 (4.04-8.63)
24-hr	1.93 (1.76-2.17)	2.58 (2.32-2.88)	3.34 (3.02-3.77)	3.98 (3.55-4.50)	4.78 (4.13-5.60)	5.38 (4.55-6.44)	5.94 (4.90-7.32)	6.63 (5.26-8.26)	7.29 (5.63-9.62)	7.88 (5.87-10.7)
2-day	2.50 (2.27-2.81)	3.28 (2.97-3.69)	4.28 (3.85-4.81)	5.04 (4.52-5.73)	6.08 (5.26-7.13)	6.82 (5.79-8.19)	7.67 (6.27-9.32)	8.32 (6.71-10.5)	9.31 (7.20-12.3)	10.0 (7.50-13.7)
3-day	2.88 (2.59-3.21)	3.72 (3.37-4.18)	4.81 (4.35-5.43)	5.68 (5.10-6.46)	6.83 (5.90-8.03)	7.89 (6.53-9.24)	8.64 (7.08-10.5)	9.38 (7.57-11.9)	10.6 (8.13-13.9)	11.4 (8.46-15.5)
4-day	3.14 (2.85-3.53)	4.07 (3.69-4.58)	5.28 (4.76-5.94)	6.21 (5.57-7.06)	7.48 (6.47-8.78)	8.40 (7.14-10.1)	9.34 (7.74-11.5)	10.3 (8.28-13.0)	11.6 (8.90-15.2)	12.6 (9.30-17.0)
7-day	3.87 (3.51-4.35)	4.99 (4.52-5.61)	6.42 (5.81-7.24)	7.67 (6.70-8.61)	9.09 (7.89-10.7)	10.2 (8.70-12.3)	11.4 (9.44-14.0)	12.6 (10.1-15.9)	14.1 (10.9-18.6)	15.3 (11.4-20.8)
10-day	4.41 (4.00-4.96)	5.87 (5.14-6.38)	7.29 (6.60-8.23)	8.69 (7.71-9.77)	10.3 (8.95-12.1)	11.8 (9.87-14.0)	12.9 (10.7-15.9)	14.2 (11.5-18.0)	16.0 (12.3-21.1)	17.3 (12.9-23.6)
20-day	5.88 (5.32-6.59)	7.66 (6.85-8.50)	9.70 (8.77-10.9)	11.4 (10.2-13.0)	13.7 (11.9-16.1)	15.3 (13.0-18.4)	17.0 (14.1-21.0)	18.7 (15.1-23.7)	20.8 (16.2-27.6)	22.8 (16.9-30.9)
30-day	7.24 (6.57-8.14)	9.32 (8.45-10.5)	12.0 (10.8-13.5)	14.0 (12.6-16.0)	16.7 (14.5-19.7)	18.8 (15.9-22.5)	20.7 (17.2-25.5)	22.7 (18.3-28.8)	25.3 (19.6-33.4)	27.3 (20.4-37.2)
45-day	8.80 (7.99-9.89)	11.3 (10.3-12.7)	14.4 (13.1-16.3)	16.9 (15.1-19.2)	20.0 (17.4-23.6)	22.4 (19.0-26.9)	24.8 (20.4-30.3)	26.8 (21.6-34.0)	29.7 (23.0-39.3)	31.8 (23.8-43.6)
60-day	10.4 (9.48-11.7)	13.4 (12.1-15.0)	17.0 (15.4-19.2)	19.8 (17.7-22.5)	23.3 (20.3-27.5)	25.9 (22.0-31.2)	28.6 (23.6-35.0)	30.9 (24.9-39.2)	34.1 (26.3-45.0)	36.4 (27.2-49.8)

¹ Precipitation frequency (PF) estimates in this table are based on frequency analysis of partial duration series (PDS).
 Numbers in parenthesis are PF estimates at lower and upper bounds of the 90% confidence interval. The probability that precipitation frequency estimates (for a given duration and average recurrence interval) will be greater than the upper bound (or less than the lower bound) is 5%. Estimates at upper bounds are not checked against probable maximum precipitation (PMP) estimates and may be higher than currently valid PMP values.
 Please refer to NOAA Atlas 14 document for more information.

[Back to Top](#)



Area = 1 acre (43560 ft²), Rv=0.89, P = 0.434 in

Full Capture Volume (FCV) = Rv (P/12) x Area

FCV = 1 (acre) x (43,560 ft²/acre) x 0.89 x 0.434 in (1 (ft) / 12 in) = **1,402 ft³**

The water quality volume for the 85th 24-hour event is larger than the 1 –year 1-hour volume, therefore the AVSF is certified as multi benefit BMP. The installation of the trash rack is recommended to prevent scour of the captured trash.

Section 8

Flow Based BMP Certification Design Method

8.1 Calculate the peak flow

Determine the one-year one-hour rainfall intensity for the site location. The listed values of rainfall intensity would be used in the Rational Formula ($Q=CiA$) to estimate runoff from areas that would discharge flow to the Treatment BMPs. The resulting peak runoff rate would then be used to demonstrate that the trash is captured from this event.

Rational Methods. (Caltrans HDM 810)

Use to determine the peak flow rate.

$$Q = CiA$$

Q = Design discharge in cubic feet per second.

C = Coefficient of runoff. Use HDM Figure 819.2A.

i = rainfall intensity in inches per hour for the selected frequency and for a duration, for this application: The region specific one-year, one-hour storm (intensity) may be obtained from the National Oceanic and Atmospheric Administration Atlas 14 Point Precipitation Frequency Estimates at [NOAA Atlas 14 Point Precipitation Frequency Estimates](#)

A = Drainage area in acres.

Caltrans Hydrology and Hydraulic methods can be found in the HDM, link provided.

[Highway Design Manual \(HDM\)](#)

8.2 Calculate the flow through the Multi Benefit treatment BMP

Treatment BMPs have multiple areas for outflow.

For example, a media filter outflows through: 1. Infiltration through filter media, 2. Flow through the overflow trash screen. 3. Flow, through the overflow mechanisms.

The locations of outflow can vary by BMP type and alternative design configurations, so designers must carefully analyze their unique design and then apply the appropriate hydraulic equations and methods. For example, in a media filter the flow goes through the media and may also leave through the over flow. For this type of BMP first calculate the flow through the media. Follow the Caltrans HDM methods for drainage design. [Highway Design Manual \(HDM\)](#)

Caltrans pilot studies have shown that the surface layer of sand controls the flow through the AVSF for filtering treatment mechanism.

Q (flow full capture) treated (AVSF with screen) = flow rate (ft^3/s) of media + flow rate through trash screen (ft^3/s).

8.3 Flow through Media

Flow through the sand filter surface media area.

1. Measure the filter media surface area.
2. Determine the flow rate of the media material.

$\text{Area (ft}^2\text{) x media permeability rate (in/hr) x (ft/12 in)(hr/60 min)(min/60 s) = flow rate (ft}^3\text{/s)}$.

Compare the media flow rate to the certification water quality event (1-year 1-hour peak flow).

If the entire flow can go through the media, then you're certified full capture. If the peak ponds, then calculate the flow through the intercept screen and media together. (This will not occur until the basin fills.)

Two methods are included that can be used to size the trash rack on the overflow: percent opening method and Orifice flow method.

Percent Opening method taken from (LA county for trash screen full capture design 2005)

8.4 Flow through trash screen

The following steps are taken to determine if the intercept screen on overflow pipes or other intercept screen BMPs, with ¼ inch (5 mm) openings are full capture devices, i.e., will treat flows from a 1-year, 1-hour storm.

1. Determine the gross area of the screen insert installed within the BMP, both horizontal, vertical, and bottom sections.
2. Determine the percentage (%) open area of the screen insert. Percentage provided by the manufacturer or Plan Sheet.
3. Determine the net area of the intercept screen. This is done by multiplying the gross area by the percentage of the open area.
4. Determine an effective pipe diameter based on the net area of the screen insert. This is done by using the area of a circle equation and solving for the diameter.
5. Interpretation of effective pipe diameter:
 - a. Greater than pipe diameter would indicate that the screen insert can treat more flow than existing outlet pipe, thus it will pass flow from a ten-year storm.
 - b. Less than pipe diameter would indicate the screen insert is unable to pass more flow than existing outlet pipe, thus it will not pass flow from a ten-year storm.
 - 1) Proceed in calculating the 1-year, 1-hour storm flow for the screen of concern using the Rational Method and using the rain intensity as determined by NOAA Atlas 14 for the location of the design or local rainfall maps where available.
 - 2) Determine an effective pipe diameter that would transport the 1-year, 1-hour flow determined above.
 - 3) Compare effective pipe diameter with actual outlet diameter. If actual outlet diameter is smaller than effective pipe diameter, insert is a full capture device.

8.5 Orifice flow perforated riser

The governing of discharge from a perforated riser structure having uniform holes at equal spacing can be calculated using equation 1-1 (City of LA Storm BMP Manual, 2010)

$$Q = C_p 2A_p/3H_s) (2g)^{1/2}H^{3/2}$$

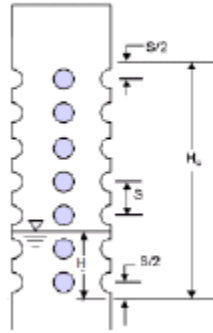

Q = riser flow discharge (cfs)

C_p = discharge coefficient for perforations (use 0.61)

A_p = cross-sectional area of all the holes (ft²)

S = center to center vertical spacing between perforations (ft)

H_s = distance from $s/2$ below the lowest row of holes to $s/2$ above the top row of holes (McEnroe 1988)

H = distance from $s/2$ below the lowest row of holes to the water surface elevation under consideration.

For iterative computations needed to size the holes in the riser and determine the riser height, a simplified version of equation 1-1 may be used.

$$Q = kH^{3/2}$$

$$k = C_p (2A_p/3H_s) (2g)^{1/2}$$

8.6 Example Flow

Demonstrate the flow through the media and overflow screen is greater than the 1-year 1- hour peak.

1. Measure the area from surveys, assume 1 acre for example.
2. Calculate the 1-year 1-hour peak event using rational method, English units

$$Q = CIA$$

C = .90 for asphalt pavement, HDM chapter 810.

Area = 1 acre or 43,560 ft²

I = intensity determine from NOAA Atlas 14 table for the project location.

Use NOAA Atlas 14 online table at Oakland station, 1-year, 1- hour event, is **0.434 in/hr**

$$Q = 0.90 \times 1 \text{ acre} \times 0.434 \text{ in/hr} = \mathbf{0.3906 \text{ ft}^3/\text{s} \text{ 1-year 1-hour peak}}$$

8.7 Flow through media

Actual flow through a sand media follows Darcy's law and will vary with depth of water and effective porosity of the sand due to clogging of the filter. Clean sand has a permeability rate of 8 in/hour. For sand filters Caltrans pilot studies have shown that the surface layer is the limiting control of the flow for treatment. Based on this we will estimate the infiltration rate through the surface sand layer for estimating the design rate of flow through the media, this rate will be actually vary with clogging and maintenance, so it is an estimated average.

Q (media flow rate) = Media Area (ft²) x media infiltration rate (in/hr) x (ft/12 in) x (hr/60 min)(min/60 s) = flow rate (ft³/s) of media + flow rate through screen.

Since the surface of the sand is the limiting factor we will use this for the filter flow rate.

$2 \text{ in/hour} \times (1 \text{ hour}/60\text{minutes}) \times (1 \text{ minute}/60 \text{ seconds}) = 0.000556 \text{ in/second} \times (1 \text{ ft}/12 \text{ in}) = 0.0000463 \text{ ft/sec}$

$1,125 \text{ ft}^2 \times 0.0000463 \text{ ft/sec} = 0.052 \text{ foot}^3/\text{second}$

0.052 foot³/second is the flow rate through the media layer at 2 in/hr clogged top layer. A more realistic rate is probably 5 in/hr between the clean sand and clogged rate.

At 5 in/hr flow rate is 0.13 foot³/second through the media layer

Q (media filter flow rate for full capture) = Media flow rate and Trash Screen intercept flow rate = flow rate (ft³/s) of media + flow rate through screen.

(AVSF media area) x 2 in/hr x 1/12 x 1/60 x 1/60 =

The dimensions for the CT AVSF 15000 can treat WQVs from 15,001 ft³ – 22,500 ft³.

15000 media area is 4.5 (depth), 45 (length) x 25 (width) = 1,125 ft²

$(1,125 \text{ ft}^2) \times (2 \text{ in/hr} \times 1/12 \times 1/60 \times 1/60) = 0.052 \text{ ft}^3/\text{s}$, then calculate the screen intercept flow of overflow screen. The screen would not actually flow, until the water reached it. This is a stepped outflow.

Total flow is the over flow screen and media added for total flow. For design compare total flow with the 1-hour 1-year flow.

Q treated for full capture (AVSF with screen) = flow rate (ft³/s) of media + flow rate through screen (ft³/s).

8.8 Example Flow through the Trash Intercept Screen

1. Trash Screen intercept dimensions given from plan sheet or manufacturer, (sheet for example).

Left horizontal section is 1.5 feet x 4.0 feet

Right horizontal section is 1.5 feet x 4.0 feet

Front vertical section is 4.0 feet by 4.0 feet

Floor Section is 1.5 feet by 4.0 feet

2. Tributary area 1.0 acres
3. Rainfall intensity is 0.434 in/hr
4. Percent open area of insert is equal to fifty percent (63%), from plan sheet
5. Street slope is 0.002 ft/ft

L horizontal section = 1.5 ft x 4.0 ft = 6 ft²

R horizontal section = $1.5 \text{ ft} \times 4.0 \text{ ft} = 6 \text{ ft}^2$

Front vertical section = $4.0 \text{ ft} \times 4.0 \text{ ft} = 16.0 \text{ ft}^2$

Floor section = $1.5 \text{ ft} \times 4.0 \text{ ft} = 6 \text{ ft}^2$

Total Gross Area = $6 \text{ ft}^2 + 6 \text{ ft}^2 + 6 \text{ ft}^2 + 16.0 \text{ ft}^2 = 34 \text{ ft}^2$

1. Determine Gross trash screen Area:
 - a. Given example Caltrans XS sheet AVSF, see XS sheet from design website and appendix A.
 - b. Dimensions of screen: 18" diameter pipe = Appendix, see "d1" from note 3 .
2. Percent open area of insert:
 - a. Open area = 63%, see CT XS plan sheet
3. Determine Net Area of Insert:
 - a. Net Area = $34 \text{ ft}^2 \times 63\%$
 - b. Net Area = 21.42 ft^2
4. Determine Effective Pipe Diameter (dnew):
 - a. Area of Circle = $\pi d^2 / 4$
 - b. $D_{\text{new}} = (4 \times \text{area} / \pi)^{1/2}$
 - c. $\text{Area}_{\text{new}} = (4 \times 21.42 \text{ ft}^2 / \pi)^{1/2}$
 - d. $D_{\text{new}} = 5.22 \text{ ft}$
5. Interpretation of Effective Pipe Diameter:

The effective pipe diameter resulted in 5.22 ft. This diameter is greater than 1.5 feet (18"), thus screen insert can pass/treat more flow than the existing outlet pipe (Example modified from the City of Los Angeles, Sanitation Department of Public works to show method). So the additive flow from the media and screen is full capture.

Section 9

Unit Hydrograph Methods

Caltrans has developed a technical memo for sizing media filters using Santa Barbara Unit hydrograph method. This can be adopted to demonstrate the treatment of approved treatment BMPs for NPDES compliance and the full capture multi-purpose certification (CTSW-TM-16-324.17.1). Other hydrograph methods may also be used to demonstrate that the flow from the 1-year 1-hour event is captured and treated. This is just one example to show alternative design methods. Due to the length of the document, this will just be referenced and available upon request to HQ Hydraulics and Storm Water Design by Caltrans designers.

Section 10

Continuous Simulation Methods

Using models that demonstrate the flow which can pass through filters for treatment and overflow screens for the certification storm sizes, other engineering hydraulic methods may be used. One method is EPA SWMM. Due the large files this is linked for free public downloads.

[Storm Water Management Model \(SWMM\)](#)

Appendix A: Plans

Multi Benefit Treatment BMP Trash Full Capture Requirements – Design Guidance

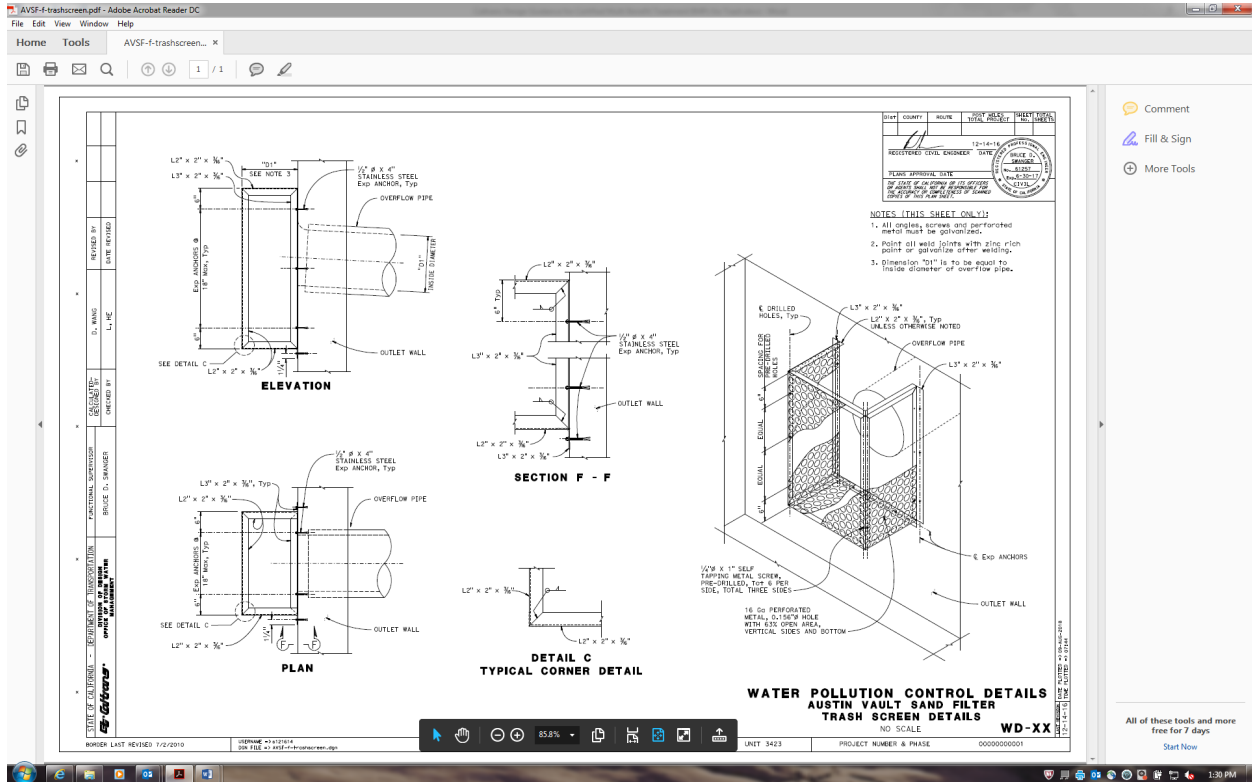

XS sheet, Media Filter trash screen WD-XX

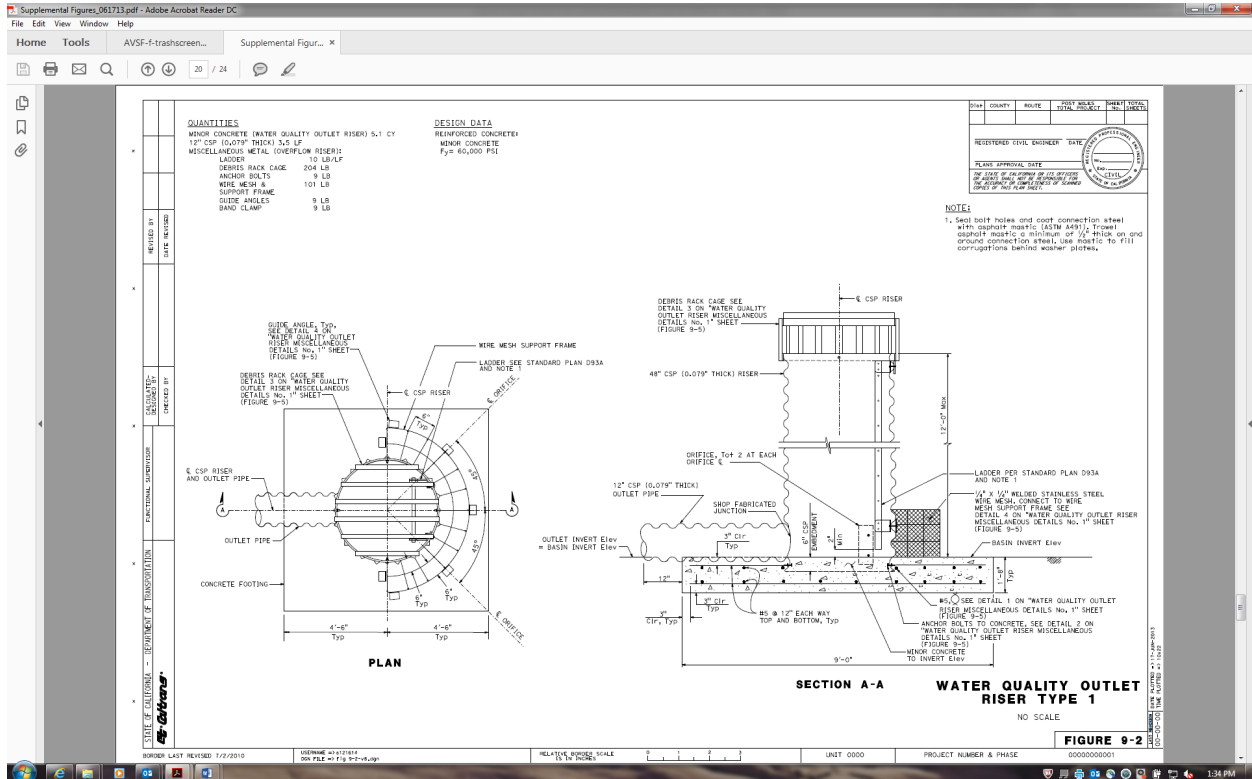

Supplemental Detail trash screen, figure 9-2



Appendix B: Orifice Flow Reference

The governing rate of discharge from a perforated riser structure having uniform holes at equal spacing can be calculated using Equation 2-1 below:

$$Q = C_p \frac{2A_p}{3H_s} \sqrt{2g} H^{3/2} \quad \text{(Equation 2-1)}$$

Where:

- Q = riser flow discharge (cfs)
- C_p = discharge coefficient for perforations (use 0.61)
- A_p = cross-sectional area of all the holes (ft²)
- s = center to center vertical spacing between perforations (ft)
- H_s = distance from $s/2$ below the lowest row of holes to $s/2$ above the top row of holes (McEnroe 1988).
- H = distance from $s/2$ below the lowest row of holes to the water surface elevation under consideration.

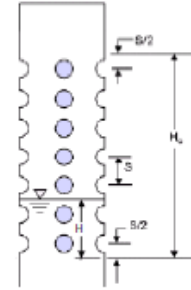

For the iterative computations needed to size the holes in the riser and determine the riser height a simplified version of Equation 2-1 may be used, as shown below in Equation 2-2:

$$Q = kH^{3/2} \quad \text{(Equation 2-2)}$$

Where:

$$k = C_p \frac{2A_p}{3H_s} \sqrt{2g} \quad \text{(Equation 2-3)}$$

Uniformly perforated riser designs are defined by the depth or elevation of the first row of perforations, the length of the perforated section of pipe, and the size or diameter of each perforation. The steps needed to size a perforated riser outlet are illustrated in Appendix C.