

Technical Report Documentation Page

1. REPORT No.

FHWA/CA/ESC-98/06 Part 3

2. GOVERNMENT ACCESSION No.**3. RECIPIENT'S CATALOG No.****4. TITLE AND SUBTITLE**

Vehicle Crash Tests of The Type 80 Bridge Rail

5. REPORT DATE

March 1999

6. PERFORMING ORGANIZATION**7. AUTHOR(S)**

Robert Meline, John Jewell, Rich Peter

8. PERFORMING ORGANIZATION REPORT No.

59-680600

9. PERFORMING ORGANIZATION NAME AND ADDRESS

Office of Materials and Foundations
California Department of Transportation
5900 Folsom Blvd.,
Sacramento, CA. 95819

10. WORK UNIT No.**11. CONTRACT OR GRANT No.**

F94TL48

12. SPONSORING AGENCY NAME AND ADDRESS

California Department of Transportation
5900 Folsom Blvd.,
Sacramento, CA. 95819

13. TYPE OF REPORT & PERIOD COVERED

Final

14. SPONSORING AGENCY CODE**15. SUPPLEMENTARY NOTES**

This project was performed in cooperation with the US Department of Transportation, Federal Highway Administration, under the research project titled "VEHICLE CRASH TESTS OF THE TYPE 70 AND AN AESTHETIC, SEE-THROUGH CONCRETE BRIDGE RAIL AND TRANSITION BARRIER".

16. ABSTRACT

An aesthetic, see-through concrete bridge rail, Type 80, was built and tested in accordance with NCHRP Report 350. The Type 80 bridge rail is an 810 mm-tall, reinforced concrete barrier. The rail has 280 mm-high by 1620 mm-long gaps, 230 mm above the bridge deck surface. The barrier tested was 23 m-long and was constructed at the Caltrans Dynamic Test Facility in West Sacramento, California.

A total of three crash tests were conducted under Report 350 test Level 4, one with a 820 kg car, one with a 2000 kg pickup truck and one with an 8000 kg single unit van truck. The results of all three tests were within the limits of the Report 350 guidelines.

The Type 80 bridge rail is recommended for approval on California highways requiring TL-4 bridge rails.

17. KEYWORDS

Barriers, Crash Test, Bridge Rail, Concrete, Vehicle Impact Test, Aesthetic, See-Through, Type 80, Type 80SW.

18. No. OF PAGES:

54

19. DRI WEBSITE LINK

<http://www.dot.ca.gov/hq/research/researchreports/1997-2001/type80.pdf>

20. FILE NAME

Type80.pdf

STATE OF CALIFORNIA
DEPARTMENT OF TRANSPORTATION
ENGINEERING SERVICE CENTER,
OFFICE OF MATERIALS AND FOUNDATIONS

**VEHICLE CRASH TESTS OF THE
TYPE 80 BRIDGE RAIL**

Supervised by Phil Stolarski, P.E.
Principal Investigator Rich Peter, P.E.
Report Prepared by Robert Meline, P.E. and John Jewell, P.E.
Research Performed by Roadside Safety Technology Unit

Rich Peter, P.E.
Senior Materials and Research Engineer

Phil Stolarski, Chief
Structural Materials Branch

Jim Stout, Chief
Office of Materials and Foundations

1. REPORT NO. FHWA/CA/ESC-98/06 Part 3		2. GOVERNMENT ACCESSION NO.		3. RECIPIENT'S CATALOG NO.	
4. TITLE AND SUBTITLE VEHICLE CRASH TESTS OF THE TYPE 80 BRIDGE RAIL				5. REPORT DATE March 1999	
				6. PERFORMING ORGANIZATION CODE	
7. AUTHOR(S) Robert Meline, John Jewell, Rich Peter				8. PERFORMING ORGANIZATION REPORT NO. 59-680600	
9. PERFORMING ORGANIZATION NAME AND ADDRESS Office of Materials and Foundations California Department of Transportation 5900 Folsom Blvd., Sacramento, CA. 95819				10. WORK UNIT NO.	
				11. CONTRACT OR GRANT NO. F94TL48	
12. SPONSORING AGENCY NAME AND ADDRESS California Department of Transportation 5900 Folsom Blvd., Sacramento CA. 95819				13. TYPE OF REPORT & PERIOD COVERED FINAL	
				14. SPONSORING AGENCY CODE	
15. SUPPLEMENTARY NOTES This project was performed in cooperation with the US Department of Transportation, Federal Highway Administration, under the research project titled "VEHICLE CRASH TESTS OF THE TYPE 70 AND AN AESTHETIC, SEE-THROUGH CONCRETE BRIDGE RAIL AND TRANSITION BARRIER".					
16. ABSTRACT An aesthetic, see-through concrete bridge rail, Type 80, was built and tested in accordance with NCHRP Report 350. The Type 80 bridge rail is an 810 mm-tall, reinforced concrete barrier. The rail has 280 mm-high by 1620 mm-long gaps, 230 mm above the bridge deck surface. The barrier tested was 23 m-long and was constructed at the Caltrans Dynamic Test Facility in West Sacramento, California. A total of three crash tests were conducted under Report 350 test Level 4, one with a 820 kg car, one with a 2000 kg pickup truck and one with an 8000 kg single unit van truck. The results of all three tests were within the limits of the Report 350 guidelines. The Type 80 bridge rail is recommended for approval on California highways requiring TL-4 bridge rails.					
17. KEY WORDS Barriers, Crash Test, Bridge Rail, Concrete, Vehicle Impact Test, Aesthetic, See-Through, Type 80, Type 80SW.				18. DISTRIBUTION STATEMENT No Restrictions. This document is available through the National Technical Information Service, Springfield, VA 22161	
19. SECURITY CLASSIF. (OF THIS REPORT) Unclassified		20. SECURITY CLASSIF. (OF THIS PAGE) Unclassified		21. NO. OF PAGES 54	22. PRICE

NOTICE

The contents of this report reflect the views of the Office of Materials and Foundations, which is responsible for the facts and the accuracy of the data presented herein. The contents do not necessarily reflect the official views or policies of the State of California or the Federal Highway Administration. This report does not constitute a standard specification or regulation.

Neither the State of California nor the United States Government endorses products or manufacturers. Trade or manufacturers' names appear herein only because they are considered essential to the object of this document.

SI CONVERSION FACTORS

<u>To Convert From</u>	<u>To</u>	<u>Multiply By</u>
ACCELERATION		
m/s ²	ft/s ²	3.281
AREA		
m ²	ft ²	10.76
ENERGY		
Joule (J)	ft.lb _f	0.7376
FORCE		
Newton (N)	lb _f	0.2248
LENGTH		
m	ft	3.281
m	in	39.37
cm	in	0.3937
mm	in	0.03937
MASS		
kg	lb _m	2.205
PRESSURE OR STRESS		
kPa	psi	0.1450
VELOCITY		
km/h	mph	0.6214
m/s	ft/s	3.281
km/h	ft/s	0.9113

ACKNOWLEDGMENTS

This work was accomplished in cooperation with the United States Department of Transportation, Federal Highway Administration.

Special appreciation is due to the following staff members of the Office of Materials and Foundations and the Office of Research for their enthusiastic and competent help on this project:

Payam Rowhani, Gary Gauthier, Mike O’Keeffe, Mike White, Glen Weldon and Larry Moore, test preparation, data reduction, vehicle preparation, and film processing; Dave Bengal, Independent Camera Operator; Bob Cullen, Eric Jacobson, Ed Ung, Danny Callaway and Walt Winter, electronic instrumentation; Gene Weyel and Bill Poroshin, machine shop services. Special thanks to Mike Arata, Jorge Jimenez and Ken Davis, the student assistants who were instrumental in helping to keep the project on schedule.

Other persons from Caltrans who made important contributions include: Robert C. Anderson, Ralph Bishop, Engineering Services Center - Office of Structures, technical consultation; Don Fogle and Ellis Hirst, Traffic Operations, technical consultation; Don Tateishi, Herb Holman and Lynn Harrison, Headquarters Photo Section; Sonny Ferreira and Bill Brook, Structures Construction.

The bridge rail was constructed by R.J. Frank Construction, Redding CA, under the supervision of Brian Baker.

TABLE OF CONTENTS

NOTICE	iii
1. INTRODUCTION	1
1.1. Problem.....	1
1.2. Objective.....	1
1.3. Background.....	1
1.4. Literature Search	2
1.5. Scope.....	2
2. TECHNICAL DISCUSSION	3
2.1. Test Conditions - Crash Tests.....	3
2.1.1. Test Facilities.....	3
2.1.2. Test Barriers.....	3
2.1.3. Construction	4
2.1.4. Test Vehicles	10
2.1.5. Data Acquisition System	10
2.2. Test Results - Crash Tests.....	11
2.2.1. Impact Description - Test 544	11
2.2.2. Vehicle Damage - Test 544	16
2.2.3. Barrier Damage - Test 544	16
2.2.4. Dummy's Response – 544.....	16
2.2.5. Impact Description - Test 545	16
2.2.6. Vehicle Damage - Test 545	21
2.2.7. Barrier Damage - Test 545	21
2.2.8. Impact Description - Test 546	21
2.2.9. Vehicle Damage - Test 546	28
2.2.10. Barrier Damage - Test 546	28
2.3. Discussion of Test Results - Crash Tests.....	28
2.3.1. General - Evaluation Methods (Tests 544-546, 548).....	28
2.3.2. Structural Adequacy	28
2.3.3. Occupant Risk.....	29
2.3.4. Vehicle Trajectory	29
3. CONCLUSION.....	33
4. RECOMMENDATION	33
5. IMPLEMENTATION.....	33
6. APPENDIX.....	34
6.1. Test Vehicle Equipment.....	34
6.2. Test Vehicle Guidance System.....	39
6.3. Photo - Instrumentation	39
6.4. Electronic Instrumentation and Data	43
6.5. Detailed Drawing.....	53
7. REFERENCES.	54

LIST OF FIGURES

Figure 2-1	Type 80 Bridge Rail	4
Figure 2-2	Concrete Anchor Block with Simulated Bridge Deck Reinforcing Steel.....	6
Figure 2-3	Simulated Bridge Deck Construction.....	6
Figure 2-4	Form Construction for Curb	7
Figure 2-5	Steel Placement for Beam Section	7
Figure 2-6	Form Placement for Beam Section.....	7
Figure 2-7	Expansion Joint Steel Placement.....	8
Figure 2-8	Top View of Forms for Beam Section	8
Figure 2-9	Concrete Work Complete	8
Figure 2-10	Completed Type 80 Bridge Rail.....	9
Figure 2-11	Completed Type 80 Bridge Rail.....	9
Figure 2-12	Backside of Completed Bridge Rail.....	9
Figure 2-13	Bridge Rail with Vehicle 544.....	12
Figure 2-14	Side View Of Vehicle 544.....	12
Figure 2-15	Rear View of Vehicle 544 and The Bridge Rail	12
Figure 2-16	Post Impact Side View of Vehicle 544	13
Figure 2-17	Close up of Passenger Side Front Damage, Vehicle 544	13
Figure 2-18	Post Impact Front View, Vehicle 544	13
Figure 2-19	Post Impact View of Barrier and Vehicle 544	14
Figure 2-20	Post Impact Bridge Rail Scuff Marks Test 544.....	14
Figure 2-21	Post Impact Bridge Rail Scuff Marks Test 544.....	14
Figure 2-22	Test 544 Data Summary Sheet	15
Figure 2-23	Vehicle and Bridge Rail before Test 545	17
Figure 2-24	Vehicle and Bridge Rail before Test 545	17
Figure 2-25	Impact Side of Vehicle before Test 545.....	17
Figure 2-26	Final Position Of Test Vehicle 545	18
Figure 2-27	Post Impact Side of Test Vehicle 545	18
Figure 2-28	Rear Post Impact View of Vehicle 545	18
Figure 2-29	Post Impact Interior View of Vehicle 545	19
Figure 2-30	Test 545 Impact Area	19
Figure 2-31	Test 545 Impact Area	19
Figure 2-32	Test 545 Data Summary Sheet	20
Figure 2-33	546 Test Vehicle.....	23
Figure 2-34	Vehicle 546 Relative To Bridge Rail	23
Figure 2-35	Rear View of 546 Test Vehicle	23
Figure 2-36	Post Test Impact Side of 546 Test Vehicle	24
Figure 2-37	Front and Left Side of Vehicle 546.....	24
Figure 2-38	Post Test Rear View	24
Figure 2-39	Close-up of Right Front Wheel Area	25
Figure 2-40	Barrier and Resting Point of Vehicle	25
Figure 2-41	Impact Area	25
Figure 2-42	Close up of Impact Area.....	26
Figure 2-43	Test 546 Data Summary Sheet	27
Figure 6-1	Camera Locations	40

Figure 6-2	Tape Switch Layout.....	42
Figure 6-3	Vehicle Accelerometer Sign Convention.....	44
Figure 6-4	Test 544 Vehicle Accelerations -vs- Time.....	45
Figure 6-5	Test 544 Vehicle Longitudinal Acceleration, Velocity and Distance -vs- Time.	46
Figure 6-6	Test 544 Vehicle Lateral Acceleration, Velocity and Distance -vs- Time.	47
Figure 6-7	Test 544 Vehicle Roll, Pitch and Yaw -vs- Time	48
Figure 6-8	Test 545 Vehicle Accelerations -vs- Time.....	49
Figure 6-9	Test 545 Vehicle Longitudinal Acceleration, Velocity and Distance -vs- Time .50	
Figure 6-10	Test 545 Vehicle Lateral Acceleration, Velocity and Distance -vs- Time	51
Figure 6-11	Test 545 Vehicle Roll, Pitch and Yaw -vs- Time	52

LIST OF TABLES

Table 1-1	Comparison of Different Test Levels.....	2
Table 1-2	Target Impact Conditions.....	3
Table 2-1	Test Vehicle Information.....	10
Table 2-2	Test 544 Assessment Summary.....	30
Table 2-3	Test 545 Assessment Summary.....	31
Table 2-4	Test 546 Assessment Summary.....	32
Table 2-5	Vehicle Trajectories and Speeds.	32
Table 6-1	Test 544 Vehicle Dimensions.....	36
Table 6-2	Test 545 Vehicle Dimensions.....	37
Table 6-3	Test 546 Vehicle Dimensions.....	38
Table 6-4	Typical Camera Type and Locations.....	40
Table 6-5	Accelerometer Specifications.....	44

1. INTRODUCTION

1.1. Problem

Most new or retrofit bridge rails on California highways since the 1970's have been the standard Caltrans solid concrete parapet, 810 mm high, with a New Jersey safety-shape profile. When districts requested a self-cleaning "see-through" bridge rail about 14 years ago, Caltrans developed a steel post and beam design, the Type 18. This design has been used infrequently because it is relatively expensive. It requires a minimum 300 mm-thick deck overhang. Though it is attached to the side of the deck, it occupies 600 mm of deck width. It is also more likely to need repairs after an impact and to exhibit corrosion problems than a reinforced concrete bridge rail. Another design that was developed was the Type 115 bridge rail. This system had problems with the wheels of impacting vehicles snagging on the posts. Additionally, neither the Type 115 nor the Type 18 met the AASHTO PL-2 requirement that the rail be able to contain an 8000 kg, medium-duty, cargo truck.

It was clear Caltrans' district offices desired an alternative bridge rail. This alternative would need to be more attractive and have better see-through characteristics than existing approved designs and meet the design criteria discussed in Section 2.1.2.1.

1.2. Objective

To crash test an 810 mm-tall, reinforced concrete bridge rail (designated throughout this report as the Type 80 bridge rail) to test level 4 in NCHRP Report 350¹. These crash testing procedures include impacts of an 820 kg sedan at 100 km/h, a 2000 kg pickup at 100 km/h and an 8000 kg truck at 80 km/h.

1.3. Background

Caltrans and other agencies have tested several bridge barrier railings in recent years. None of these designs nor the ten railings in the AASHTO "Roadside Design Guide"² meet Caltrans' current requirements for an aesthetic, see-through railing. Of the ten railings listed in the AASHTO Guide, four are concrete barriers which are not see-through. Three out of the ten are mounted on reinforced concrete posts, or on concrete curbs and parapets. None of the designs have been tested to retain the 8000 kg truck. One of these (the Oklahoma TR-1 bridge rail) is a see-through, self-cleaning design, but the aesthetics of the rail are arguable. The size of the posts and rail are too large to provide good see-through qualities. The other three designs are based on three beam and w-section guardrail which do not provide the see-through, low maintenance or aesthetic properties that Caltrans wants in a bridge rail.

A few years ago California crash tested the Type 115 bridge rail³. It consists of two structural steel rails on structural steel posts that are mounted on the side of the bridge deck. Even though the design could structurally withstand impacts from pickup trucks at 100 km/h, there were some problems with front wheel snagging on the posts during the tests. The railing was consequently downgraded to a PL-1 level as defined in the AASHTO "Guide Specifications for Bridge Railings"⁴ and is only recommended for use on narrow, low-volume, low-speed roads.

1. INTRODUCTION (continued)

The Type 80 bridge rail was designed using the AASHTO “Guide Specifications for Bridge Railings” requirements. The AASHTO Guide Specifications stipulate that a bridge rail to be used for high-speed applications must conform to PL-2 level testing. However, according to the FHWA, the PL-2 test level has since been replaced by the similar NCHRP Report 350 test level 4, so the railing was tested according to test level 4 criteria. Table 1-1 summarizes the testing requirements for PL-2 and Test Level 4, including test vehicle masses and vehicle impact angles. Notice that the pickup truck weight is different in AASHTO than in NCHRP Report 350. Nevertheless, the higher impact angle required in Report 350 provides a higher impact severity because the kinetic energy due to the lateral component of the impact velocity is 33% higher. Test level 4 requires testing with an 8,000 kg, two-axle, single-unit truck in addition to the 820 kg sedan and the 2000 kg pickup.

Table 1-1 Comparison of Different Test Levels

Test Level	Vehicle (kg)	Nominal Speed (km/h)	Nominal Angle, θ (deg)
AASHTO PL-2	816	97	20
	2449	97	20
	8165	80	15
NCHRP Report 350 Test Level 4	820	100	20
	2000	100	25
	8000	80	15

1.4. Literature Search

A literature search using the TRIS, NTIS, and the Compendex Plus databases was conducted at the beginning of the project to find research reports or publications related to the objectives of this project. There were two references found and both were for the Texas Type T411^{5, 6}. The Texas T411 is a concrete beam and post bridge rail 813 mm high by 305 mm thick and contains openings 203 mm wide by 457 mm high. This rail had not been tested to the Report 350 or PL-2 requirements discussed above. The post arrangement also made it difficult to see through the rail except at near perpendicular angles. In addition, the post configuration seemed to provide an excessively high effective coefficient of friction⁶. The Texas T411 did not meet Caltrans’ requirements.

1.5. Scope

A total of three tests were performed and evaluated in accordance with NCHRP Report 350. The testing matrix established for this project is shown in Table 1-2.

Table 1-2 Target Impact Conditions

Test Number	Barrier Type	Mass (kg)	Speed (km/h)	Angle (deg)
544	Type 80	820	100	20
545	Type 80	2000	100	25
546	Type 80	8000	80	15

2. TECHNICAL DISCUSSION

2.1. Test Conditions - Crash Tests

2.1.1. Test Facilities

Each of the crash tests was conducted at the Caltrans Dynamic Test Facility in West Sacramento, California. The test area is a large, flat, asphalt concrete surface. There were no obstructions nearby except for a 2 m-high earth berm 40 m downstream from the bridge rail. A temporary bridge deck was constructed for the purpose of this project.

2.1.2. Test Barriers

2.1.2.1. Design

The Type 80 bridge rail was designed to meet specific design criteria. The bridge rail had to be crash-worthy according to the latest federal guidelines as well as functional, aesthetically pleasing and allow a partial view otherwise obscured by a "solid" concrete rail design.

The general shape of the barrier was selected for three main reasons. The first reason was to provide a partial view through the rail. A viewing space 310 mm high by 1620 mm long was originally chosen to meet structural and safety requirements. Testing conducted on the Type 80SW bridge rail⁷ provided evidence of potential wheel snagging and the space height was reduced to 280 mm. The second reason for the general shape was based on the satisfactory results of previous testing concerning wheel snagging potential on posts³ and involved setting the posts back 100 mm from the barrier beam face. The final reason was to provide an aesthetically pleasing rail. This was kept in mind during the design process and a conscious effort was made to provide a clean and simple-appearing rail while meeting the other design criteria.

The functionality of a concrete rail was another desired feature. The low maintenance of concrete is advantageous in regard to long-term costs and roadside worker exposure. In general, concrete barriers see less damage and require fewer repairs. There is also a decreased corrosion problem in marine environments and there are fewer specially-fabricated, galvanized parts in a concrete barrier compared with a steel barrier. After the purpose of the barrier was resolved, the design criteria were applied.

The design criteria were based on highway safety design standards and material specifications. Section 13 from NCHRP Project 12-33 "Development of a Comprehensive Bridge Specification and Commentary"⁸ and the 1989 AASHTO "Guide Specifications for

2. TECHNICAL DISCUSSION (continued)

Bridge Railings” were used as guidelines for the design standard. These guidelines were followed for Performance Level Two (PL-2) crash test requirements. Material specifications for the steel reinforcement and concrete were provided by the July, 1995 Caltrans "Standard Specifications"⁹. Once the design criteria were evaluated and the necessary changes were incorporated, a specific configuration was determined.

The design configuration for the Type 80 bridge rail includes viewing spaces 280 mm high by 1620 mm long, chosen to meet structural and safety requirements. A structural cross-section is shown in Figure 2-1. The reinforcing steel is covered with a minimum of 25 mm of concrete and all longitudinal reinforcing is terminated in 90 degree hooks. The 810 mm-high design was used in the tests as the shortest configuration to be placed in service. This provided a more conservative test configuration for the evaluation. Additional details for the Type 80 bridge rail can be found in Appendix 6.5.

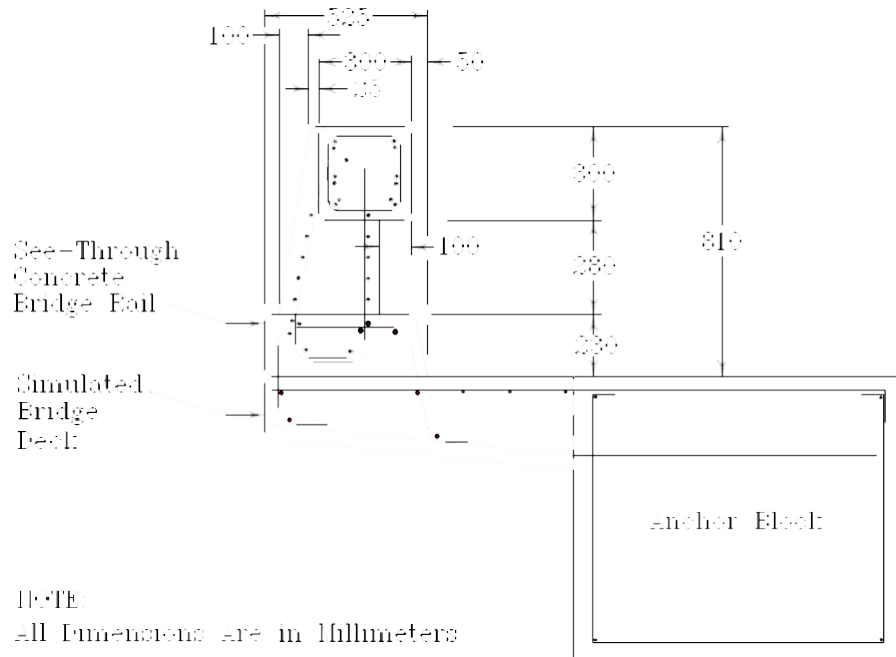

Figure 2-1 Type 80 Bridge Rail

2.1.3. Construction

The Type 80 bridge rail was constructed at the north end of the Caltrans Dynamic Test Facility in West Sacramento, California. The north end of the facility was chosen in order to accommodate the trajectory and acceleration distance needed for the 8000 kg test vehicle. Over 600 m of test track were made available for testing, with 550 m used to get the self-powered vehicle up to speed. A simulated bridge deck was attached to an existing anchor block for the bridge rail installation.

2. TECHNICAL DISCUSSION (continued)

The bridge rail was constructed in several stages. An existing anchor block with a simulated bridge deck was utilized for the new bridge rail. The existing simulated bridge deck was demolished with the reinforcing steel retained for use in the new deck, shown in Figure 2-2. Additional reinforcing steel was added to the steel retained, including bars which looped up out of the deck approximately 200 mm above the deck surface. The forms for the new simulated deck were completed and concrete was poured level to the deck surface, Figure 2-3. Forms were then placed to support the concrete and reinforcing steel for the barrier base and posts, Figure 2-4.

Next, the reinforcing steel was installed for the beam section of the barrier, Figure 2-5 through Figure 2-8. Longitudinal reinforcing for the beam was mechanically butt spliced in place. After all of the post and beam reinforcing was tied in place and the forms set, the last concrete pour was completed. In all occurrences wood forms were used and the concrete was vibrated. Figure 2-10 through Figure 2-12 depict the completed barrier.

2. TECHNICAL DISCUSSION (continued)

Figure 2-2 Concrete Anchor Block with Simulated Bridge Deck Reinforcing Steel



Figure 2-3 Simulated Bridge Deck Construction



2. TECHNICAL DISCUSSION (continued)

Figure 2-4 Form Construction for Curb



Figure 2-5 Steel Placement for Beam Section

Figure 2-6 Form Placement for Beam Section



2. TECHNICAL DISCUSSION (continued)

Figure 2-7
Expansion Joint
Steel Placement



Figure 2-8 Top
View of Forms for
Beam Section

Figure 2-9
Concrete Work
Complete



2. TECHNICAL DISCUSSION (continued)

Figure 2-10
Completed Type 80
Bridge Rail



Figure 2-11
Completed Type 80
Bridge Rail

Figure 2-12
Backside of
Completed Bridge
Rail



2.1.4. Test Vehicles

The test vehicles complied with NCHRP Report 350. For all tests, the vehicles were in good condition, free of major body damage and were not missing structural parts. All of the vehicles had standard equipment and front-mounted engines. The vehicle inertial masses were within recommended limits (Table 2-1) except for test vehicle 545. Test vehicle 545 was 8 kg below the 1955 kg lower recommended mass value due to a ballast calculation error that was found after the test. The lower mass was determined to have negligible effect on the test.

Table 2-1 Test Vehicle Information

Test No.	Vehicle	Ballast (kg)	Test Inertial (kg)
544	1994 Geo Metro	0	799
545	1994 Chevrolet 2500	14	1947
546	1993 GMC Top Kick	2994	8056

Except for the Geo, all the vehicles were self-powered; a speed control device limited acceleration once the impact speed had been reached. The Geo was connected by a steel cable to another vehicle and towed to impact speed. Remote braking was possible at any time during the test for all vehicles through a tetherline. A short distance before the point of impact, each vehicle was released from the guidance rail and the ignition was turned off (for the Geo, the tow cable was released). A detailed description of the test vehicle equipment and guidance systems is contained in Sections 6.1 and 6.2 of the Appendix.

2.1.5. Data Acquisition System

The impact phase of each crash test was recorded with seven high-speed 16 mm movie cameras, one normal-speed 16 mm movie camera, one Beta format video camera, one 35 mm still camera with an autowinder and one 35 mm sequence camera. The test vehicles and the barrier were photographed before and after impact with a normal-speed 16 mm movie camera, a Beta format video camera and a color 35 mm camera. A film report of this project was assembled using edited portions of the film coverage.

Two sets of orthogonal accelerometers were mounted at the centers of gravity in test vehicles 544 and 545. An additional set of orthogonal accelerometers was mounted 600 mm behind the center of gravity in test vehicle 544. Rate gyro transducers were also placed at the centers of gravity of test vehicles 544 and 545 to measure the roll, pitch and yaw. The data were used in calculating the occupant impact velocities and ridedown accelerations, and maximum vehicle rotation.

2. TECHNICAL DISCUSSION (continued)

An anthropomorphic dummy was used in Test 544 to obtain motion data. The dummy, a Hybrid III built to conform to Federal Motor Vehicle Safety Standards by the Humanoid Systems Division, Humanetics, Inc., simulated a 50th percentile American male weighing 75 kg. The dummy was placed in the passenger's seat and was restrained with a lap and shoulder belt.

A digital transient data recorder (TDR), Pacific Instruments model 5600, was used to record electronic data during the tests. The digital data were analyzed using a desktop computer.

2.2. Test Results - Crash Tests

A film report with edited footage from tests 544, 545 and 546 has been compiled and is available for viewing.

2.2.1. Impact Description - Test 544

The measured speed of the vehicle on impact with the barrier was 111.1 km/h with an angle of 20 degrees. The impact speed was substantially above the intended 100 km/h and was due to improper speed obtained by the tow vehicle. Impact occurred 10.0 m from the upstream end of the 23-m long bridge rail.

Contact with the bridge rail continued for approximately 2.5 m, determined by visible marks on the rail. The left rear wheel rose off the ground to a maximum of 0.1 to 0.15 m. As shown in Figure 2-19 through Figure 2-21, there were some black tire marks on the face of the barrier posts, but there was no evidence of wheel snagging. At 0.097 s after impact, the dummy's head was out of the right front passenger window. The dummy's head did not come into contact with the barrier or any other items and returned to its original position once the lateral accelerations decreased.

The exit angle and speed of the car were 9.8 degrees and 99 km/h, respectively. The brakes were applied approximately 13 m after impact with the bridge rail. The stopping point for the vehicle was about 57 m from the point of last contact with the barrier. The vehicle remained upright throughout and after the collision.

2. TECHNICAL DISCUSSION (continued)

Figure 2-13
Bridge Rail with
Vehicle 544



Figure 2-14 Side
View Of Vehicle 544

Figure 2-15
Rear View of
Vehicle 544 and
The Bridge Rail



2. TECHNICAL DISCUSSION (continued)

Figure 2-16 Post Impact Side View of Vehicle 544



Figure 2-17 Close up of Passenger Side Front Damage, Vehicle 544

Figure 2-18 Post Impact Front View, Vehicle 544



2. TECHNICAL DISCUSSION (continued)

Figure 2-19 Post Impact View of Barrier and Vehicle 544



Figure 2-20 Post Impact Bridge Rail Scuff Marks Test 544

Figure 2-21 Post Impact Bridge Rail Scuff Marks Test 544



2. TECHNICAL DISCUSSION (continued)

Figure 2-22 Test 544 Data Summary Sheet

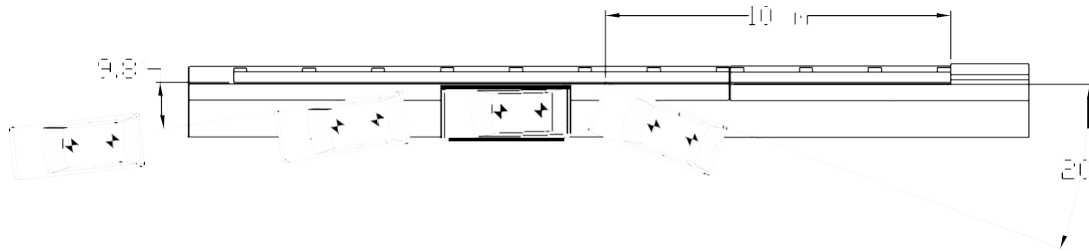
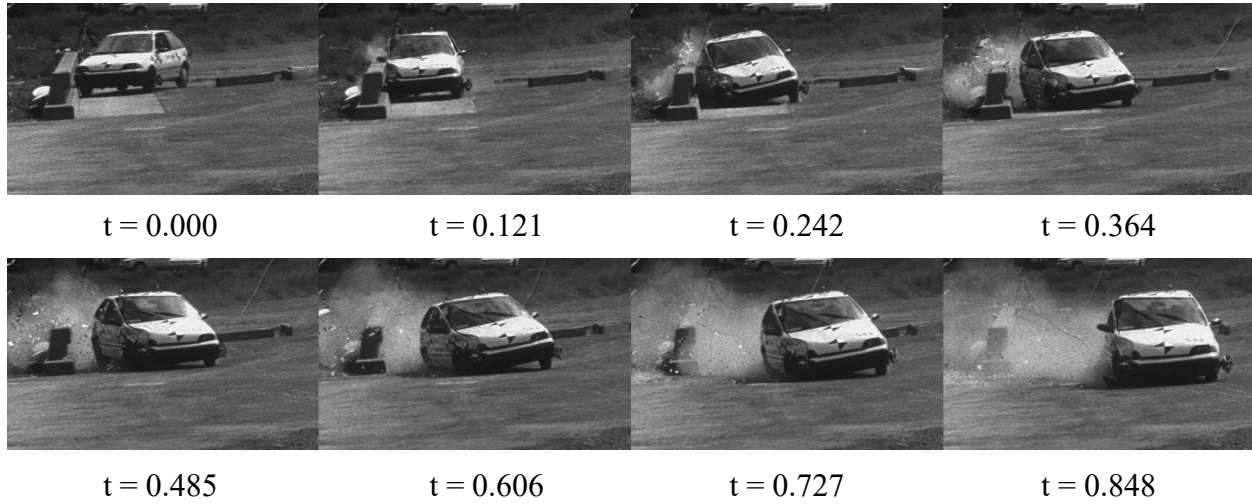

General Information:

Test Agency California DOT
 Test Number 544
 Test Date September 16, 1998

Test Article:

Name Type 80 bridge rail
 Installation Length... 23.1 m
 Description Post and beam reinforced concrete bridge railing

Test Vehicle:

Model 1994 Geo Metro
 Inertial Mass 799 kg

Impact Conditions:

Velocity 111.1 km/h
 Angle 20°

Exit Conditions:

Velocity 99 km/h
 Angle 9.8°

Test Dummy:

Type Hybrid III
 Weight / Restraint 75 kg / lap, shoulderbelt
 Position Front Right

Vehicle Exterior:

VDS¹⁰ FR-5, RD-4
 CDC¹¹ 02RFEW3

Vehicle Interior:

OCDI¹ RF000000

Barrier Damage: Superficial scuffing

<i>Occupant Risk Values</i>	<i>Longitudinal</i>	<i>Lateral</i>
Occupant Impact Velocity	6.69 m/s	7.46 m/s
Ridedown Acceleration	-2.99 g	-8.15 g
Max. 50ms avg. Acceleration	-10.68 g	-14.07 g

2.2.2. Vehicle Damage - Test 544

The right front section of the vehicle sustained crushing of the bumper and frame, damage to the suspension and a flat tire, Figure 2-16 through Figure 2-18. The right side of the vehicle from the front bumper to the rear bumper was scraped during contact with the beam section of the rail. The hood was also crushed on the right side but remained attached at the latch and hinges.

The right door was pushed rearward about 90 mm and did not function. The left door and hatch functioned normally. The windshield was severely cracked but was not torn or penetrated. All of the windows on the right side of the car were broken. The hatch glass and left side glass were not cracked. The right front "A" pillar crinkled less than 25 mm along its length and was pushed rearward about 55 mm. The dash on the passenger side was pushed back about 60 mm.

The interior of the vehicle experienced approximately 70 mm of deformation in the front passenger floorboard area and minor buckling. There was negligible occupant compartment deformation elsewhere.

2.2.3. Barrier Damage - Test 544

Barrier damage was cosmetic only, consisting of scrapes and tire marks. Both of the right side tires left marks on the curb and beam section of the bridge rail. Small amounts of concrete spalled from the face of the barrier where the vehicle's sheet metal and wheels made contact.

2.2.4. Dummy's Response – 544

The dummy was lap and shoulder belted. It remained upright and secure during the test. The final resting position of dummy was upright in the passenger's seat.

2.2.5. Impact Description - Test 545

The measured speed of the vehicle on impact with the bridge rail was 100.8 km/h with an angle of 25.0°. Impact with the bridge rail occurred 10.3 m from the upstream end of the 23 m-long bridge rail.

The vehicle stayed in contact with the rail for approximately 4.2 m. The exit angle and speed were 7 ° and 88.5 km/h respectively. The vehicle remained upright throughout and after the collision. Brakes were applied 0.829 s after initial contact with the rail and the stopping point for the vehicle was 58 m from the point of last contact with the barrier. Figure 2-26 through Figure 2-28 shows the vehicle in its resting position.

2. TECHNICAL DISCUSSION (continued)

Figure 2-23
Vehicle and Bridge
Rail before Test 545



Figure 2-24
Vehicle and Bridge
Rail before Test 545

Figure 2-25
Impact Side of
Vehicle before
Test 545



2. TECHNICAL DISCUSSION (continued)

Figure 2-26 Final Position Of Test Vehicle 545



Figure 2-27 Post Impact Side of Test Vehicle 545

Figure 2-28 Rear Post Impact View of Vehicle 545



2. TECHNICAL DISCUSSION (continued)

Figure 2-29 Post Impact Interior View of Vehicle 545

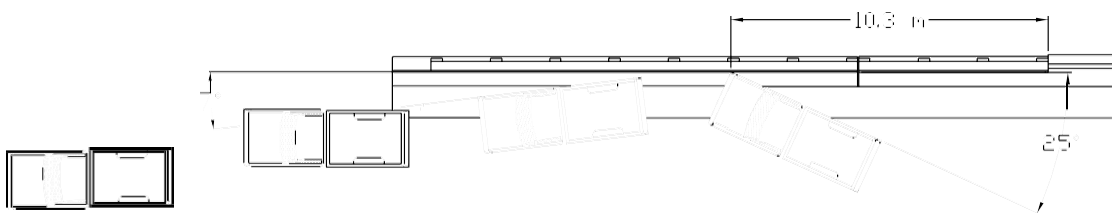
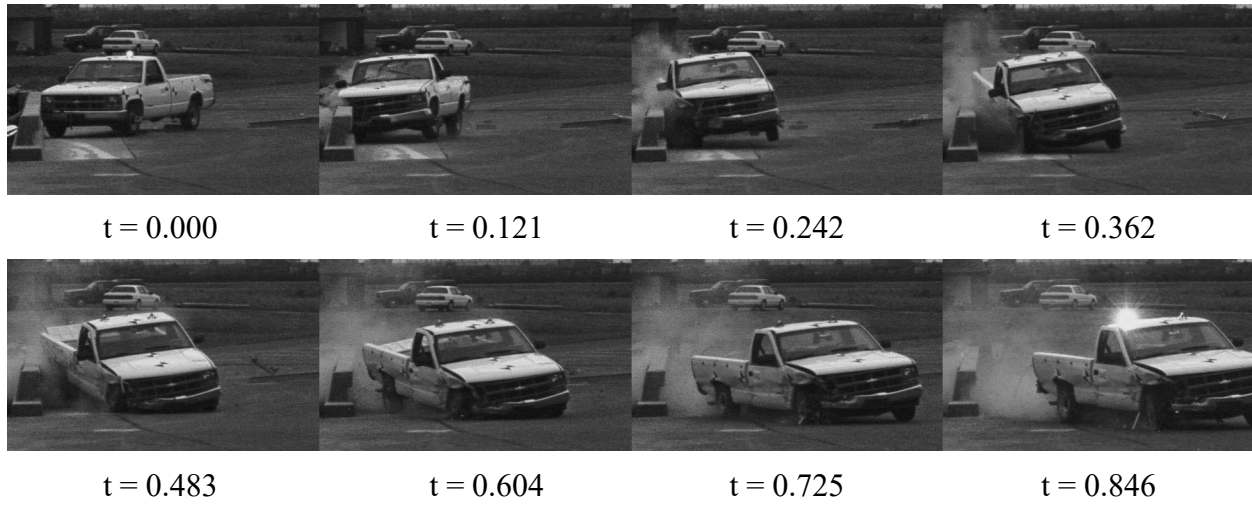

Figure 2-30 Test 545 Impact Area

Figure 2-31 Test 545 Impact Area



Figure 2-32 Test 545 Data Summary Sheet



General Information:

Test Agency California DOT
 Test Number 545
 Test Date December 2, 1998

Test Article:

Name Type 80 bridge rail
 Installation Length... 23.1 m
 Description Post and beam reinforced concrete bridge railing

Test Vehicle:

Model 1994 Chevrolet 2500
 Inertial Mass 1947 kg

Impact Conditions:

Velocity 100.8 km/h
 Angle 25°

Exit Conditions:

Velocity 88.5 km/h
 Angle 7°

Test Dummy:

Type None used
 Weight / Restraint NA
 Position NA

Vehicle Exterior:

VDS¹⁰ FR-5, RD-6
 CDC¹¹ 02RFEW9

Vehicle Interior:

OCDI¹ RF0011000

Barrier Damage: The barrier sustained minor spalling from the point of impact to 2 m downstream. Other barrier damage was cosmetic, consisting of scrapes and tire marks, with no structural damage.

<i>Occupant Risk Values</i>	<i>Longitudinal</i>	<i>Lateral</i>
Occupant Impact Velocity	5.76 m/s	6.97 m/s
Ridedown Acceleration	-3.51 g	-8.60 g
Max. 50ms avg. Acceleration	-8.86 g	+13.52 g

2.2.6. Vehicle Damage - Test 545

The vehicle received damage from the right front corner to the right rear corner, Figure 2-27. The right front and right rear wheel rims were deformed and the tires deflated. The left side wheels and tires were undamaged. The spare tire was forced from its undercarriage storage location and ended up about 15 m from the vehicle resting position.

The right front suspension was also damaged. The tie rod was broken off its mount and the A-arm and torque bar were pushed back. The spring and shock absorber were deformed but remained attached. There was no apparent damage to the suspension of the other wheels.

The initial impact occurred on the right front quarter panel, resulting in substantial buckling and scraping, Figure 2-27. The right side of the bumper was pushed back about 260 mm. As the vehicle continued along the rail the entire right side was deformed where it contacted the bridge rail beam face. As a result, the right door did not operate due to moderate buckling and scraping. The truck bed was also scraped and buckled along the right side and the entire bed shifted to the right 40 mm. The tailgate did not function but the hood and left door were left in good condition and were operable. The roof of the truck did not have any signs of buckling. The windshield was cracked but remained mounted. The left and rear windows were not cracked.

Moderate deformation occurred in the passenger compartment. There was moderate floorboard buckling with the transmission tunnel rising about 100 mm. At various locations under the passenger seat, the sheet metal buckled upward a maximum of about 75 mm. The mounting locations for the seat were not effected, meaning the seat itself would not have been pushed upward. The “A” pillar on the right side was pushed back about 25 mm with no obvious buckling along its length. The dash had minor deformation. The vehicle engine started after the test.

2.2.7. Barrier Damage - Test 545

The barrier received minor scraping and spalling, mainly at the lower edge of the beam section. Other barrier damage was cosmetic only, consisting of scrapes and tire marks. Both of the right side tires left marks along the face of the barrier.

2.2.8. Impact Description - Test 546

The 8056 kg van-bodied truck impacted the bridge rail at 80.1 km/h and 15.0 degrees. The impact location was 0.7 m in front of the bridge rail expansion joint, Figure 2-42. At impact the vehicle rolled to the right lifting both left wheels off the ground about 0.8 m. The U-bolt holding the front right leaf springs to the front axle broke, allowing the right front wheel to be pushed back under the cab, Figure 2-39. The vehicle continued to make contact with the barrier for 5 m. The approximate exit angle of the truck after it left contact with the beam face was 8 degrees. The truck then righted itself and continued to move away from the barrier at a shallow angle. The brakes were applied and the truck came to rest about 30 m and 65 m, respectively, from the point of impact, Figure 2-40.

2. TECHNICAL DISCUSSION (continued)

The 2994 kg of ballast, comprised of two separate pallets of sand bags strapped down to the cargo floor, shifted slightly during impact. The front pallet shifted about 0.1 m and the rear 0.2 m. Each pallet was constrained by 150-mm angle iron on all sides. The sand bags were secured with polyethylene stretch wrap film and 100-mm trucking straps. To provide consistent and realistic testing conditions for the 8000S test vehicle, Report 350 recommends that the cargo ballast have a center of mass 1.70 m above the ground. To obtain the proper vertical center of mass for the ballast an additional wooden pallet was added under the existing loaded pallet. Consequently, the top pallet was not supported laterally allowing the pallet and sandbags to shift. It is unlikely that the shifting sand affected the test significantly. None of the sandbags broke loose during the test, and only small amounts of sand leaked from a couple of bags.

Figure 2-33 546
Test Vehicle



Figure 2-34
Vehicle 546
Relative To Bridge
Rail

Figure 2-35
Rear View of 546
Test Vehicle



2. TECHNICAL DISCUSSION (continued)

Figure 2-36 Post Test Impact Side of 546 Test Vehicle



Figure 2-37 Front and Left Side of Vehicle 546

Figure 2-38 Post Test Rear View



2. TECHNICAL DISCUSSION (continued)

Figure 2-39
Close-up of Right
Front Wheel Area



Figure 2-40
Barrier and Resting
Point of Vehicle

Figure 2-41
Impact Area



2. TECHNICAL DISCUSSION (continued)



Figure 2-42 Close up of Impact Area

2. TECHNICAL DISCUSSION (continued)

Figure 2-43 Test 546 Data Summary Sheet

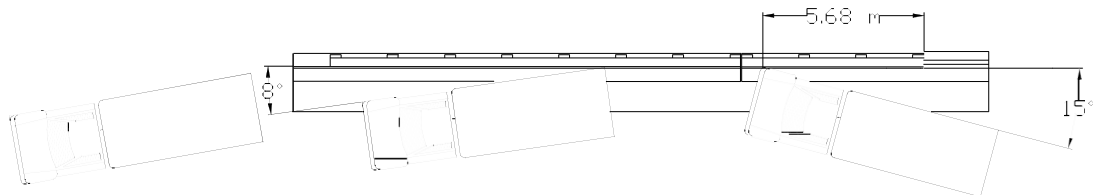
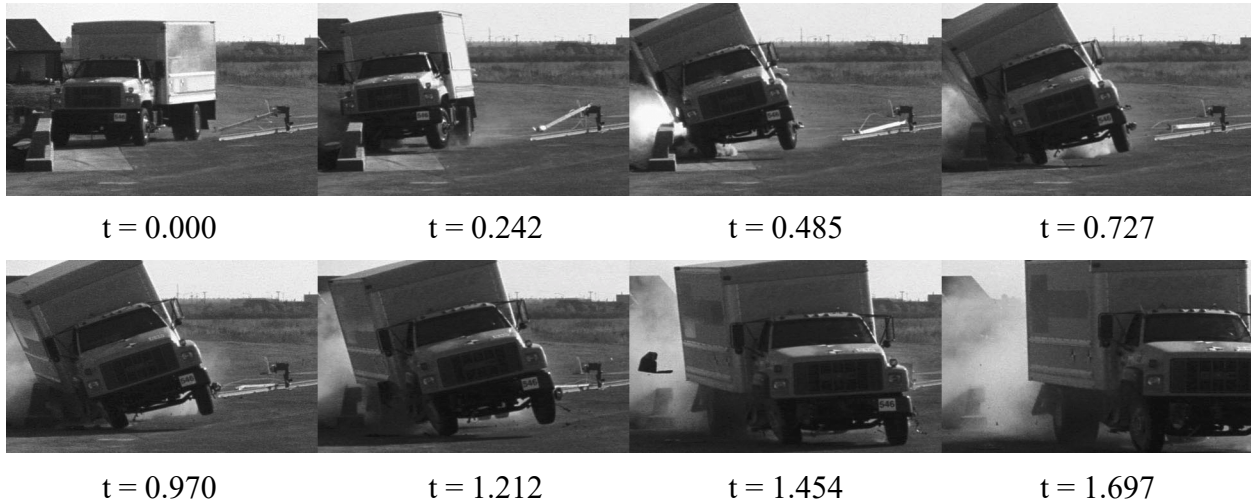

General Information:

Test Agency California DOT
 Test Number 546
 Test Date November 4, 1998

Test Article:

Name Type 80 bridge rail
 Installation Length... 23.1 m
 Description..... Post and beam reinforced
 concrete bridge railing

Test Vehicle:

Model 1993 GMC TopKick
 Inertial Mass 8056 kg
 Ballast 2994 kg

Impact Conditions:

Velocity 80.1 km/h
 Angle 15.0°

Exit Conditions:

Velocity 64.7 km/h
 Angle 8°

Test Dummy:

Type None used
 Weight / Restraint NA
 Position NA

Vehicle Exterior:

VDS10 NA
 CDC11 NA

Vehicle Interior:

OCDI1 RF0000000

Barrier Damage: The barrier sustained minor spalling near the point of impact and at the expansion joint. Other barrier damage was cosmetic, consisting of scrapes and tire marks, with no structural damage.

<i>Occupant Risk Values</i>	<i>Longitudinal</i>	<i>Lateral</i>
Occupant Impact Velocity	Not measured	
Ridedown Acceleration	Not measured	
Max. 50ms avg. Acceleration	Not measured	

2.2.9. Vehicle Damage - Test 546

The majority of damage occurred to the right front corner of the truck. The impacting tire was pushed back into the rear of the wheel well which severed the u-bolt connecting the leaf springs to the front axle. The steering rod and front axle on the right side were bent rearward. The battery box, located directly under the passenger door was completely crushed. The fuel tank was pushed rearward and moderately deformed while in contact with the beam face, Figure 2-39.

The right front wheel received substantial scraping on the studs from contact with the bridge rail concrete, with little other damage. All of the tires remained inflated except the outside right rear dual tire, which was deflated when the outer rim was bent during impact.

The cargo box had negligible deformation, but shifted to the right on the frame about 40 mm. All of the glass including the windshield remained intact and unbroken. Both doors functioned and there was no apparent occupant compartment deformation. The engine functioned after the test and the truck was driven from the run out area with very limited steering ability.

2.2.10. Barrier Damage - Test 546

The bridge rail was scraped along the curb and beam section face leaving exposed patches of aggregate and concrete spalls. Most of the spalling occurred 0.75 m upstream of the expansion joint and at the expansion joint, Figure 2-42. The spalls were minor in nature and could be easily repaired. Additional marks were left on the bridge rail from the trucks tires. The right front and rear tires were painted blue and red, respectively.

2.3. Discussion of Test Results - Crash Tests

2.3.1. General - Evaluation Methods (Tests 544-546, 548)

NCHRP Report 350 stipulates that crash test performance be assessed according to three evaluation factors: 1) Structural Adequacy, 2) Occupant Risk, and 3) Vehicle Trajectory.

The structural adequacy, occupant risk and vehicle trajectories associated with both barriers were evaluated in comparison with Tables 3.1 and 5.1 of NCHRP Report 350.

2.3.2. Structural Adequacy

The structural adequacy of the bridge rail is acceptable. There was negligible movement of the rail during any of the tests. During the time of contact between the test vehicles and the barriers there were minor amounts of scraping and spalling.

2. TECHNICAL DISCUSSION (continued)

A detailed assessment summary of structural adequacy is shown in Table 2-2 through Table 2-4.

2.3.3. Occupant Risk

The occupant risk for the Type 80 bridge rail is also acceptable. In each of the tests, the spalling concrete did not exhibit any tendency to penetrate (or show sign of penetration) into the occupant compartment of the vehicles. All of the calculated occupant ridedown accelerations and occupant impact velocities were within the "preferred" range.

Please refer to Table 2-2 through Table 2-4 for a detailed assessment summary of occupant risk.

2.3.4. Vehicle Trajectory

The vehicle trajectory for the Type 80 bridge rail testing is also acceptable. The detailed assessment summaries of vehicle trajectories may be seen in Table 2-5.

2. TECHNICAL DISCUSSION (continued)

Table 2-2 Test 544 Assessment Summary

Test No. 544
 Date September 16, 1998
 Test agency California Dept. of Transportation

Evaluation Criteria	Test Results	Assessment									
<p>Structural Adequacy</p> <p>A. Test article should contain and redirect the vehicle; the vehicle should not penetrate, underride, or override the installation although controlled lateral deflection of the article is acceptable</p>	<p>The vehicle was contained and smoothly redirected</p>	<p>pass</p>									
<p>Occupant Risk</p> <p>D. Detached elements, fragments or other debris from the test article should not penetrate or show potential for penetrating the occupant compartment, or present an undue hazard to other traffic, pedestrians, or personnel in a work zone. Deformation of, or intrusions into, the occupant compartment that could cause serious injuries should not be permitted.</p> <p>F. The vehicle should remain upright during and after collision although moderate roll, pitching and yawing are acceptable</p> <p>H. Occupant impact velocities (see Appendix A, Section A5.3 for calculation procedure) should satisfy the following:</p> <table border="1" data-bbox="228 1125 846 1304"> <thead> <tr> <th colspan="3">Occupant Impact Velocity Limits (m/s)</th> </tr> <tr> <th>Component</th> <th>Preferred</th> <th>Maximum</th> </tr> </thead> <tbody> <tr> <td>Longitudinal and lateral</td> <td>9</td> <td>12</td> </tr> </tbody> </table>	Occupant Impact Velocity Limits (m/s)			Component	Preferred	Maximum	Longitudinal and lateral	9	12	<p>The impact resulted only in a small amount of barrier spalling. Debris generated was insignificant. There was no significant deformation of the occupant compartment.</p> <p>The maximum roll, pitch and yaw were 5.49°, -4.71°, and -28.85°, respectively. These are all acceptable.</p> <p>Long. Occ. Impact Vel. = 6.69 m/s Lat. Occ. Impact Vel. = 7.46 m/s</p>	<p>pass</p> <p>pass</p>
Occupant Impact Velocity Limits (m/s)											
Component	Preferred	Maximum									
Longitudinal and lateral	9	12									
<p>I. Occupant Ridedown Accelerations (see Appendix A, Section A5.3 for calculation procedure) should satisfy the following:</p> <table border="1" data-bbox="228 1413 846 1587"> <thead> <tr> <th colspan="3">Occupant Ridedown Acceleration Limits (g)</th> </tr> <tr> <th>Component</th> <th>Preferred</th> <th>Maximum</th> </tr> </thead> <tbody> <tr> <td>Longitudinal and lateral</td> <td>15</td> <td>20</td> </tr> </tbody> </table>	Occupant Ridedown Acceleration Limits (g)			Component	Preferred	Maximum	Longitudinal and lateral	15	20	<p>Longitudinal Acceleration. = -2.99 g Lateral Acceleration. = -8.15 g</p>	<p>pass</p>
Occupant Ridedown Acceleration Limits (g)											
Component	Preferred	Maximum									
Longitudinal and lateral	15	20									
<p>Vehicle Trajectory</p> <p>K. After collision it is preferable that the vehicle's trajectory not intrude into adjacent traffic lanes</p> <p>M. The exit angle from the test article preferably should be less than 60 percent of the test impact angle, measured at time of vehicle loss of contact with test device."</p>	<p>The vehicle maintained a relatively straight course after exiting the barrier</p> <p>The exit angle was 9°, or 45% of the impact angle.</p>	<p>pass</p> <p>pass</p>									

2. TECHNICAL DISCUSSION (continued)

Table 2-3 Test 545 Assessment Summary

Test No. 545
 Date December 2, 1998
 Test agency California Dept. of Transportation

Evaluation Criteria	Test Results	Assessment
<p>Structural Adequacy</p> <p>A. Test article should contain and redirect the vehicle; the vehicle should not penetrate, underride, or override the installation although controlled lateral deflection of the article is acceptable.</p>	<p>The vehicle was contained and smoothly redirected</p>	<p>pass</p>
<p>Occupant Risk</p> <p>D. Detached elements, fragments or other debris from the test article should not penetrate or show potential for penetrating the occupant compartment, or present an undue hazard to other traffic, pedestrians, or personnel in a work zone. Deformation of, or intrusions into, the occupant compartment that could cause serious injuries should not be permitted.</p> <p>F. The vehicle should remain upright during and after collision although moderate roll, pitching and yawing are acceptable.</p>	<p>Only moderate amounts of spalling were created during impact. There was no significant debris from the vehicle.</p> <p>The maximum roll, pitch and yaw were -12.8, -10.23, and -33.58°, respectively. These are all acceptable.</p>	<p>pass</p> <p>pass</p>
<p>Vehicle Trajectory</p> <p>K. After collision it is preferable that the vehicle's trajectory not intrude into adjacent traffic lanes.</p> <p>L. The occupant impact velocity in the longitudinal direction should not exceed 12 m/sec and the occupant ridedown acceleration in the longitudinal direction should not exceed 20g.</p> <p>M. The exit angle from the test article preferably should be less than 60 percent of the test impact angle, measured at time of vehicle loss of contact with test device."</p>	<p>The vehicle maintained a relatively straight course after exiting the barrier.</p> <p>Long. Occ. Impact Vel. = 5.76 m/s Long. Occ. Ridedown = -3.51 g</p> <p>Exit angle = 7°, 28% of the impact angle.</p>	<p>pass</p> <p>pass</p> <p>pass</p>

2. TECHNICAL DISCUSSION (continued)

Table 2-4 Test 546 Assessment Summary

Test No. 546
 Date November 4, 1998
 Test agency California Dept. of Transportation

Evaluation Criteria	Test Results	Assessment
<p>Structural Adequacy</p> <p>A. Test article should contain and redirect the vehicle; the vehicle should not penetrate, underride, or override the installation although controlled lateral deflection of the article is acceptable</p>	The vehicle was contained and smoothly redirected	pass
<p>Occupant Risk</p> <p>D. Detached elements, fragments or other debris from the test article should not penetrate or show potential for penetrating the occupant compartment, or present an undue hazard to other traffic, pedestrians, or personnel in a work zone. Deformation of, or intrusions into, the occupant compartment that could cause serious injuries should not be permitted.</p> <p>G. It is preferable, although not essential, that the vehicle remain upright during and after collision.</p>	<p>There was not any significant debris from the test article and negligible deformation of the occupant compartment.</p> <p>The vehicle remained upright</p>	<p>pass</p> <p>pass</p>
<p>Vehicle Trajectory</p> <p>K. After collision it is preferable that the vehicle's trajectory not intrude into adjacent traffic lanes</p> <p>M. The exit angle from the test article preferably should be less than 60 percent of the test impact angle, measured at time of vehicle loss of contact with test device."</p>	<p>The vehicle maintained a relatively straight course after exiting the barrier</p> <p>Exit angle =8°, 53% of the impact angle.</p>	<p>pass</p> <p>pass</p>

Table 2-5 Vehicle Trajectories and Speeds

Test Number	Impact Angle [deg]	60% of Impact Angle [deg]	Exit Angle [deg]	Impact Speed, V_i [km/h]	Exit Speed, V_e [km/h]	Speed Change $V_i - V_e$ [km/h]
544	20.0	12.0	9.8	111.1	99	12.1
545	25.0	15.0	7	100.8	88.5	12.3
546	15.0	9.0	8	80.1	64.7	15.4

3. CONCLUSION

Based on the testing of the Type 80 bridge rail discussed in this report, the following conclusions can be drawn:

1. The Type 80 bridge rail can smoothly and successfully contain and redirect an 820 kg sedan impacting at 20 degrees and 100 km/h.
2. The Type 80 bridge rail can successfully contain and redirect a 2000 kg pickup truck impacting at 25 degrees and 100 km/h.
3. The Type 80 bridge rail can successfully contain and redirect an 8000 kg single unit van-bodied truck impacting at 15 degrees and 80 km/h.
4. Damage to the Type 80 bridge rail in accidents similar to the tests conducted for this project will result in small to moderate amounts of scraping and spalling of the rail. Therefore, the majority of impacts into the rail will not require urgent repairs.
5. The Type 80 bridge rail meets the criteria set in the National Cooperative Highway Research Program's Report 350 "Recommended Procedures for the Safety Performance Evaluation of Highway Features" under Test Level 4 for longitudinal barriers.

4. RECOMMENDATION

The Type 80 bridge rail is recommended for use as a new or retrofit bridge railing on low and high-speed highways.

5. IMPLEMENTATION

The Office of Structures Design will be responsible for the preparation of standard plans and specifications for the Type 80 bridge rail, with technical support from the Office of Materials and Foundations and the Traffic Operations Program. Similarly, the Office of Structures Design, with assistance from the Office of Materials and Foundations and the Traffic Operations Program, will be responsible for the in-service evaluation.

6. APPENDIX

6.1. *Test Vehicle Equipment*

The test vehicles were modified as follows for the crash tests:

The gas tanks on the test vehicles were disconnected from the fuel supply line and drained. For tests 545 and 546, a 12 L safety gas tank was installed in the truck bed or non-impact cab step and connected to the fuel supply line. The stock fuel tanks had dry ice or gaseous CO₂ added in order to purge the gas vapors and eliminate oxygen. For Test 544, a 12 L safety tank was not installed because the vehicle was towed to impact instead of self-powered.

One pair of 12-volt, wet cell, motorcycle storage batteries were mounted in the vehicle. The batteries operated the solenoid-valve braking/accelerator system, rate gyros and the electronic control box. A second 12-volt deep cycle gel cell battery powered the transient data recorder.

A 4800 kPa CO₂ system, actuated by a solenoid valve, controlled remote braking after impact and emergency braking if necessary. Part of this system was a pneumatic ram which was attached to the brake pedal. The operating pressure for the ram was adjusted through a pressure regulator during a series of trial runs prior to the actual test. Adjustments were made to assure the shortest stopping distance without locking up the wheels. When activated, the brakes could be applied in less than 100 milliseconds.

The remote brakes were controlled at a console trailer. A cable ran from the console trailer to an electronic instrumentation trailer. From there, the remote brake signal was carried on one channel of a multi-channel tether line that was connected to the test vehicle. Any loss of continuity in these cables would have activated the brakes and cut off the ignition automatically. Also, when the brakes were applied by remote control from the console trailer, the ignition for self powered vehicle was automatically cut by removing power to the coil.

For Test 544, the vehicle speed was regulated by the speed of a tow vehicle. The tow vehicle pulled a tow cable through a series of sheaves arranged to produce a 2:1 mechanical advantage. Vehicle speed control was attained through a calibrated speedometer in the tow vehicle.

For tests 545 and 546, an accelerator switch was located on the rear fender of the vehicle. The switch opened an electric solenoid which, in turn, released compressed CO₂ from a reservoir into a pneumatic ram that had been attached to the accelerator pedal. The CO₂ pressure for the accelerator ram was regulated to the same pressure of the remote braking system with a valve to adjust CO₂ flow rate.

For tests 545 and 546, a speed control device, connected in-line with the ignition module signal to the coil, was used to regulate the speed of the test vehicle based on the signal from the vehicle transmission speed sensor. This device was calibrated prior to the test by conducting a series of trial runs through a speed trap comprised of two tape switches set a specified distance apart and a digital timer.

6. APPENDIX (continued)

For tests 545 and 546, a microswitch was mounted below the front bumper and connected to the ignition system. A trip plate on the ground near the impact point triggered the switch when the truck passed over it. The switch opened the ignition circuit and shut off the vehicle's engine prior to impact.

6. APPENDIX (continued)

Table 6-1 Test 544 Vehicle Dimensions

DATE: 8-19-98 TEST NO: 544 VIN NO: 2CIMR2464R6803042 MAKE: GEO
 MODEL: METRO YEAR: 1994 ODOMETER: 45305.7(MI) TIRE SIZE: 155R12
 TIRE INFLATION PRESSURE: 36(PSI)

MASS DISTRIBUTION (kg) LF 236.9 RF 215.9 LR 179.0 RR 167.5

DESCRIBE ANY DAMAGE TO VEHICLE PRIOR TO TEST: None

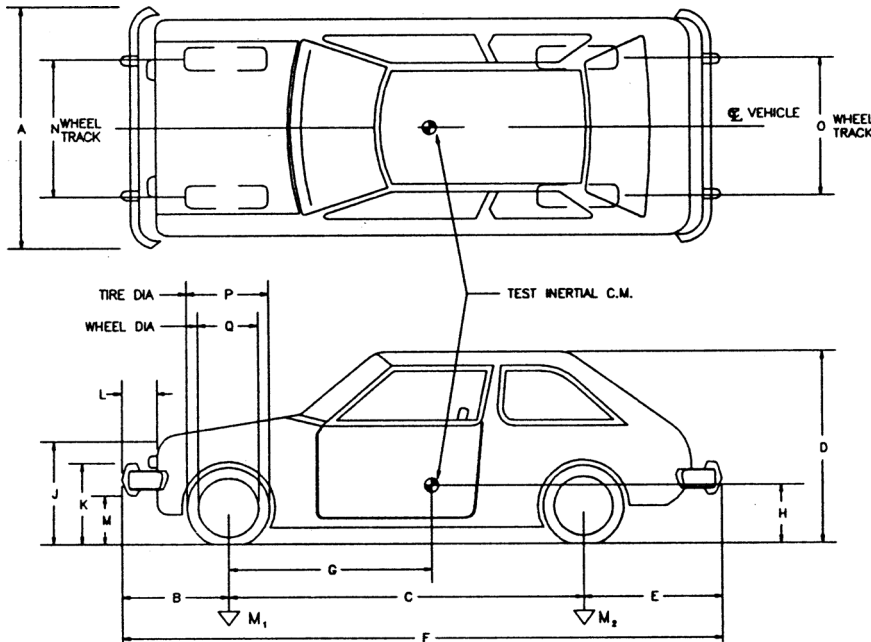

ENGINE TYPE: IN-LINE 3 CYL.

ENGINE CID: 1.0 LITER

TRANSMISSION TYPE :

 AUTO

 X MANUAL

OPTIONAL EQUIPMENT:

DUMMY DATA:

TYPE: HYBRID II 50th %

MASS: 75 KG

SEAT POSITION: RIGHT FRONT

GEOMETRY (cm)

A	154	D	134	G	97.7	K	51	N	136	Q	33.5
B	76	E	72	H	N/A	L	9.5	O	133.9		
C	225	F	376	J	67	M	26	P	56		

MASS - (kg)	<u>CURB</u>	<u>TEST INERTIAL</u>	<u>GROSS STATIC</u>
M1	<u>437</u>	<u>453</u>	<u>490.5</u>
M2	<u>300</u>	<u>346.5</u>	<u>384</u>
MT	<u>737</u>	<u>799.5</u>	<u>874.5</u>

6. APPENDIX (continued)

Table 6-2 Test 545 Vehicle Dimensions

DATE: 11/13/98 TEST NO: 545 VIN NO: 1GCFC24HORE235723 MAKE: CHEVROLET
 MODEL: 2500 C/K Pick-Up YEAR: 1994 ODOMETER: 53189 (MI) TIRE SIZE: LT 225 175R16
 TIRE INFLATION PRESSURE: 65 (PSI)

MASS DISTRIBUTION (kg) LF 540.4 RF 516.5 LR 443.2 RR 446.9

DESCRIBE ANY DAMAGE TO VEHICLE PRIOR TO TEST: NONE

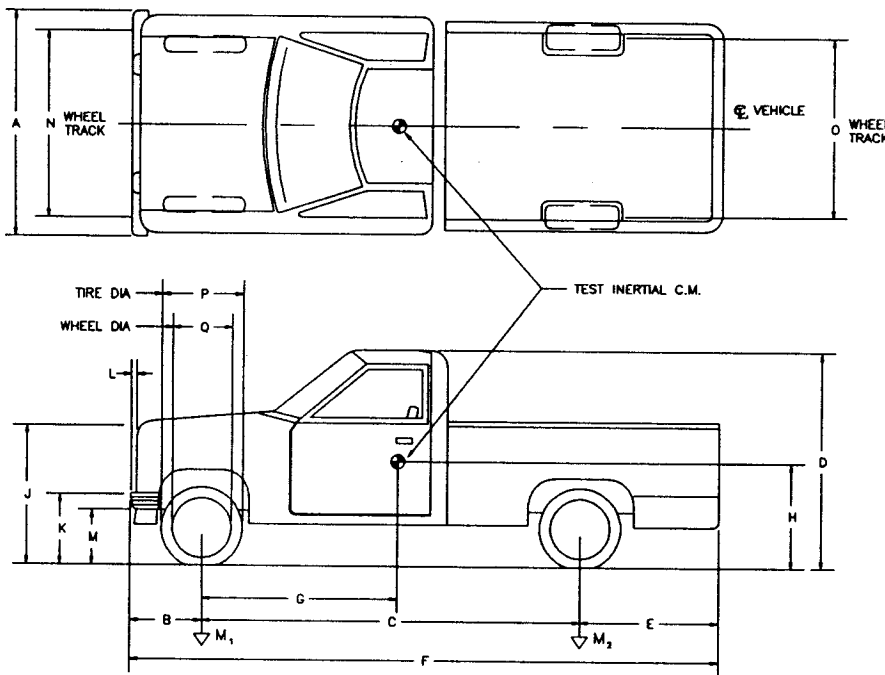

ENGINE TYPE: V8
 ENGINE CID: 5.0L
 TRANSMISSION TYPE :
 AUTO
 MANUAL
 OPTIONAL EQUIPMENT:

 DUMMY DATA:
 TYPE: NA
 MASS: NA
 SEAT POSITION: NA

GEOMETRY (cm)

A	195.3	D	177.8	G	145.0	K	58.5	N	156.5	Q	44.5
B	85.0	E	129.6	H		L	7.5	O	161.5		
C	337.2	F	555.6	J	99.5	M	36.9	P	74.0		

MASS - (kg)	CURB	TEST INERTIAL	GROSS STATIC
M1	1059.5	1056.9	1056.9
M2	800.5	890.1	890.1
MT	1859.0	1947	1947

6. APPENDIX (continued)

Table 6-3 Test 546 Vehicle Dimensions

DATE: 10/16/98 TEST NO: 546 VIN NO: 1GDJ7H1PXPJ505120 MAKE: GMC

MODEL: TopKick YEAR: 1993 ODOMETER: 101532.7 (MI) TIRE SIZE: 11R22.5

MASS DISTRIBUTION, Test Inertial (kg) Front Axle 2617 Rear Axle 5439

DESCRIBE ANY DAMAGE TO VEHICLE PRIOR TO TEST: Right front outer fender panel has been replaced with an unpainted panel.

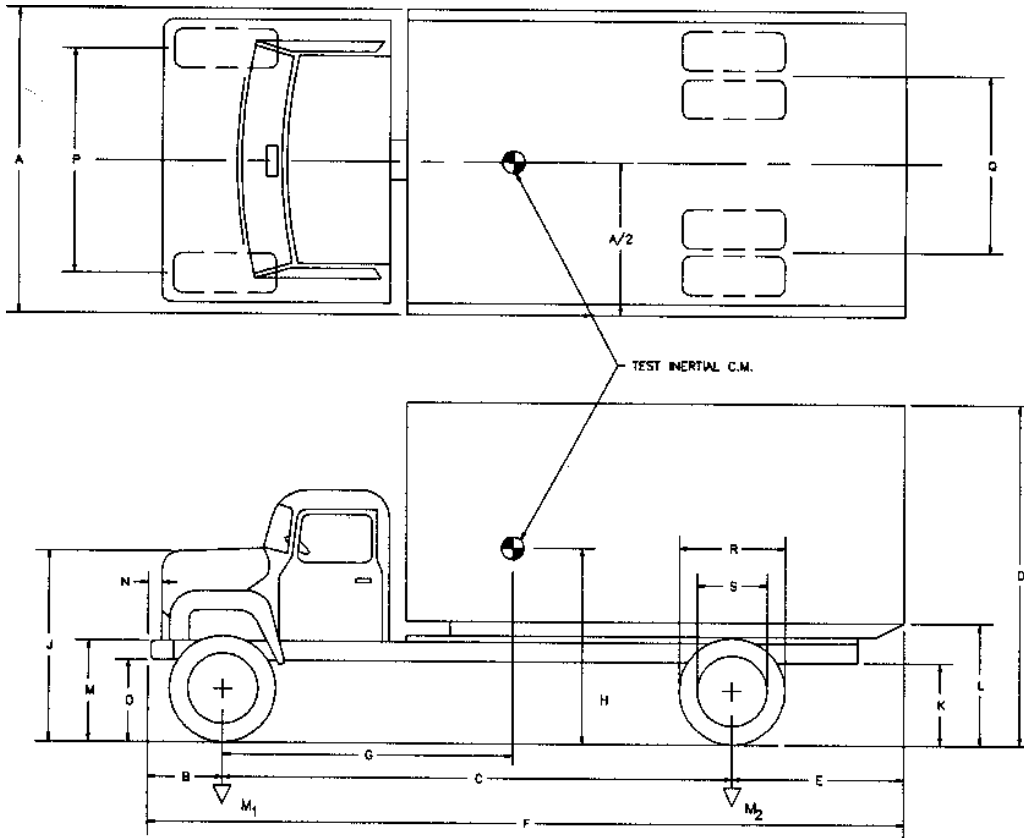

GEOMETRY (cm)

A	244.0	D	336.0	G		K	75.0	N	12.0	Q	182.0
B	86.0	E	227.0	H		L	125.0	O	59.0	R	103.5
C	530.5	F	844.0	J	175.0	M	96	P	202.0	S	59.5

MASS - (kg)	CURB	TEST INERTIAL	GROSS STATIC
M1	2150	2617	2617
M2	2885	5439	5439
MT	5062	8056	8056

6.2. *Test Vehicle Guidance System*

A rail guidance system directed the vehicle into the barrier. The guidance rail, anchored at 3.8 m intervals along its length, was used to guide a mechanical arm which was attached to the front left wheel of each of the vehicles. A plate and lever were used to trigger the release mechanism on the guidance arm, thereby releasing the vehicle from the guidance system before impact.

6.3. *Photo - Instrumentation*

Several high-speed movie cameras recorded the impact during the crash tests. The types of cameras and their locations are shown in Figure 6-1 and Table 6-4.

All of these cameras were mounted on tripods except the three that were mounted on a 10.7 m-high tower directly over the impact point on the test barrier.

A video camera and a 16 mm film camera were turned on by hand and used for panning during the test. Switches on a console trailer near the impact area remotely triggered all other cameras. The test vehicle and test barrier were photographed before and after impact with a normal-speed movie camera, a beta video camera and a color still camera. A film report of this project has been assembled using edited portions of the crash testing coverage.

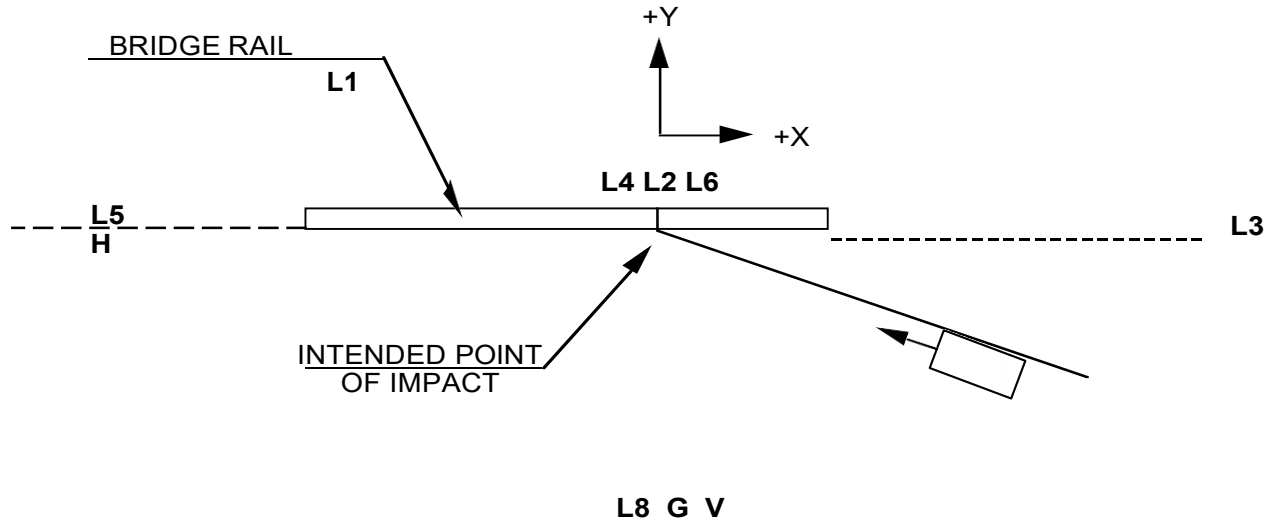

Figure 6-1 Camera Locations

Typical Coordinates, m						
Camera Label	Film Size (mm)	Camera Type	Rate: (fr./sec.)	Test 544, 545, 546		
				X*	Y*	Z*
L1	16	LOCAM 1	400	-30	9	1.5
L2	16	LOCAM 2	400	0	0	12.0
L3	16	LOCAM 3	400	30	0.1	1.5
L4	16	LOCAM 4	400	0	-0.6	12.0
L5	16	LOCAM 5	400	-70	-0.2	3.5
L6	16	LOCAM 6	400	0	0.6	12.0
L8	16	LOCAM 8	400	0.5	-15	1.5
G	16	GISMO	64	-5	-19	6
V	1.27	SONY BETACAM	30	-3	-14	1.5
H	35	HULCHER	40	-70	-1.7	3.5

Note: Camera location measurements were surveyed after each test. For each test in this series the cameras were placed in nearly identical locations allowing the average location to be recorded in this table.
*X, Y and Z distances are relative to the impact point.

Table 6-4 Typical Camera Type and Locations

The following are the pretest procedures that were required to enable film data reduction to be performed using a film motion analyzer:

- 1) Butterfly targets were attached to the top and sides of each test vehicle. The targets were located on the vehicle at intervals of 0.305, 0.610 and 1.219 meters (1, 2 and 4 feet.). The targets established scale factors and horizontal and vertical alignment. The test barrier was targeted with stenciled numbers every 1 or 2 meters..

2) Flashbulbs, mounted on the test vehicle, were electronically triggered to establish 1) initial vehicle-to-barrier contact, and 2) the time of the application of the vehicle brakes. The impact flashbulbs begin to glow immediately upon activation, but have a delay of several milliseconds before lighting up to full intensity.

3) Five tape switches, placed at 4 m intervals, were attached to the ground near the barrier and were perpendicular to the path of the test vehicle. Flash bulbs were activated sequentially when the tires of the test vehicle rolled over the tape switches. The flashbulb stand was placed in view of most of the cameras. The flashing bulbs were used to correlate the cameras with the impact events and to calculate the impact speed independent of the electronic speed trap. The tape switch layout is shown in Figure 6-2.

4) High-speed cameras had timing light generators which exposed red timing pips on the film at a rate of 100 per second. The pips were used to determine camera frame rates.

6.4. *Electronic Instrumentation and Data*

For tests 544 and 545 transducer data were recorded on a Pacific Instruments digital transient data recorder (TDR) model 5600, which was mounted in the vehicle. The transducers mounted on the two vehicles included two sets of accelerometers and one set of rate gyros at the center of gravity. For test 544 an additional set of accelerometers were mounted 600 mm behind the center of gravity. The TDR data were reduced using a desktop computer.

Three pressure-activated tape switches were placed on the ground in front of the test barrier. They were spaced at carefully measured intervals of 4 m. When the test vehicle tires passed over them, the switches produced sequential impulses or "event blips" which were recorded concurrently with the accelerometer signals on the TDR, serving as "event markers". A tape switch on the front bumper of the vehicle closed at the instant of impact and triggered two events: 1) an "event marker" was added to the recorded data, and 2) a flash bulb mounted on the top of the vehicle was activated. A time cycle was recorded continuously on the TDR with a frequency of 500 Hz. The impact velocity of the vehicle could be determined from the tape switch impulses and timing cycles. Two other tape switches, connected to a speed trap, were placed 4 m apart just upstream of the test barrier specifically to establish the impact speed of the test vehicle. The tape switch layout for all tape switches is shown in Figure 6-2.

The data curves are shown in Figure 6-4 through Figure 6-11 and include the accelerometer and rate gyro records from the test vehicles. They also show the longitudinal velocity and displacement versus time. These plots were needed to calculate the occupant impact velocity defined in NCHRP Report 350. All data were analyzed using software written by DADiSP and modified by Caltrans.

NOTE: There are no data plots for Test 543 because NCHRP Report 350 did not require accelerometer data.

Table 6-5 Accelerometer Specifications

TYPE	LOCATION	RANGE	ORIENTATION	TEST NUMBER
ENDEVCO	VEHICLE C.G.	100 G	LONGITUDINAL	544, 545
ENDEVCO	VEHICLE C.G.	100 G	LATERAL	544, 545
ENDEVCO	VEHICLE C.G.	100 G	VERTICAL	544, 545
HUMPHREY	VEHICLE C.G.	180 DEG/SEC	ROLL	544, 545
HUMPHREY	VEHICLE C.G.	90 DEG/SEC	PITCH	544, 545
HUMPHREY	VEHICLE C.G.	180 DEG/SEC	YAW	544, 545
ENDEVCO	VEHICLE C.G.	100 G	LONGITUDINAL	544, 545
ENDEVCO	VEHICLE C.G.	100 G	LATERAL	544, 545
ENDEVCO	VEHICLE C.G.	100 G	VERTICAL	544, 545

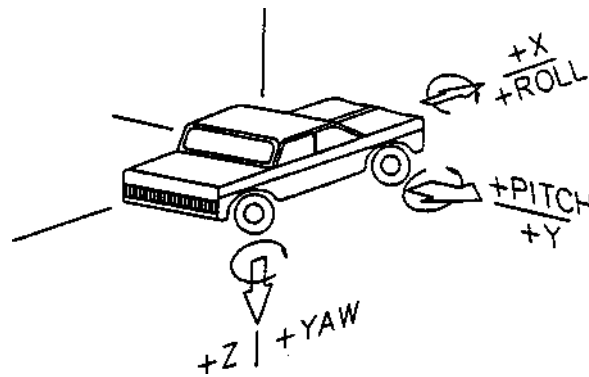
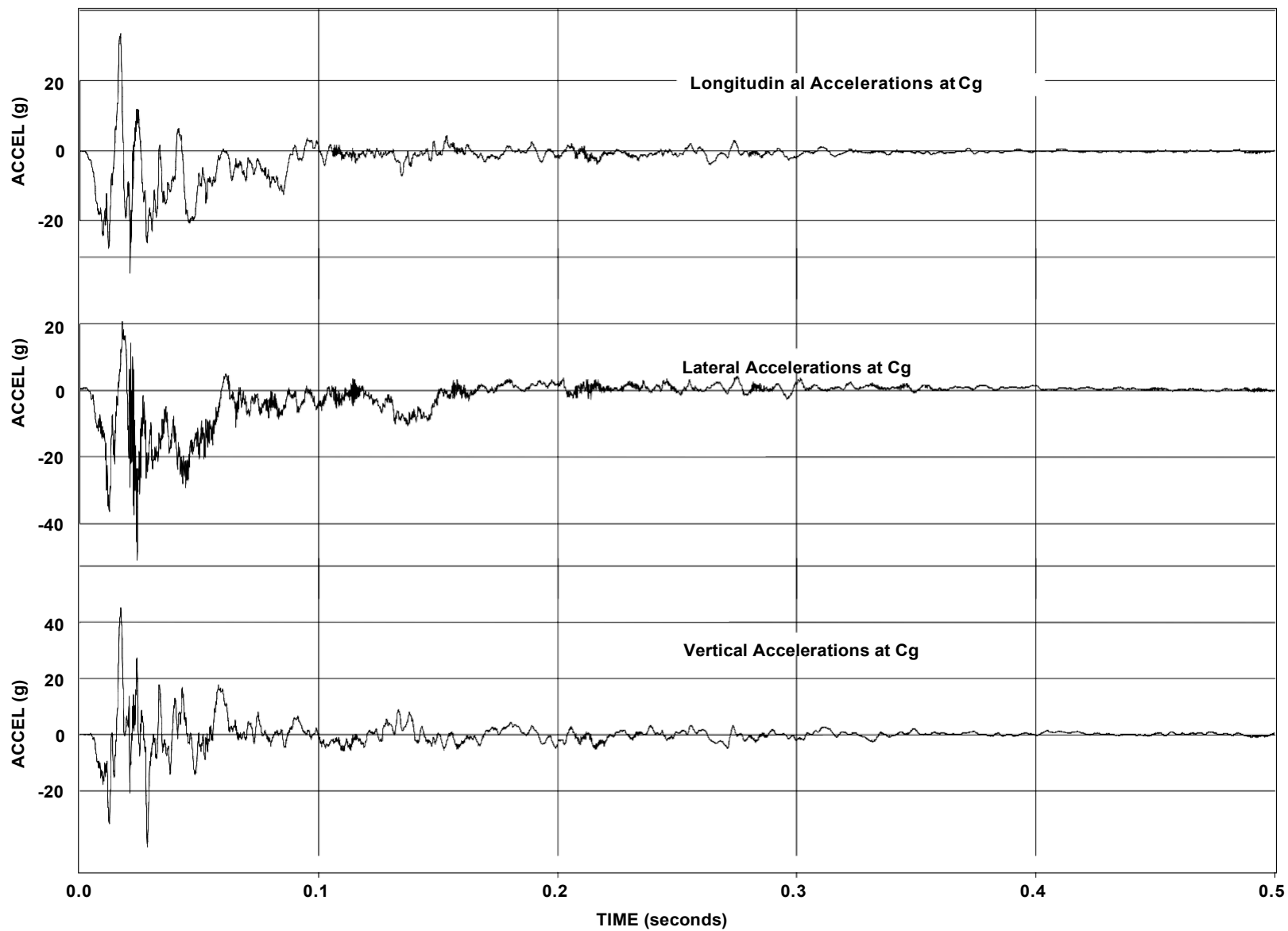
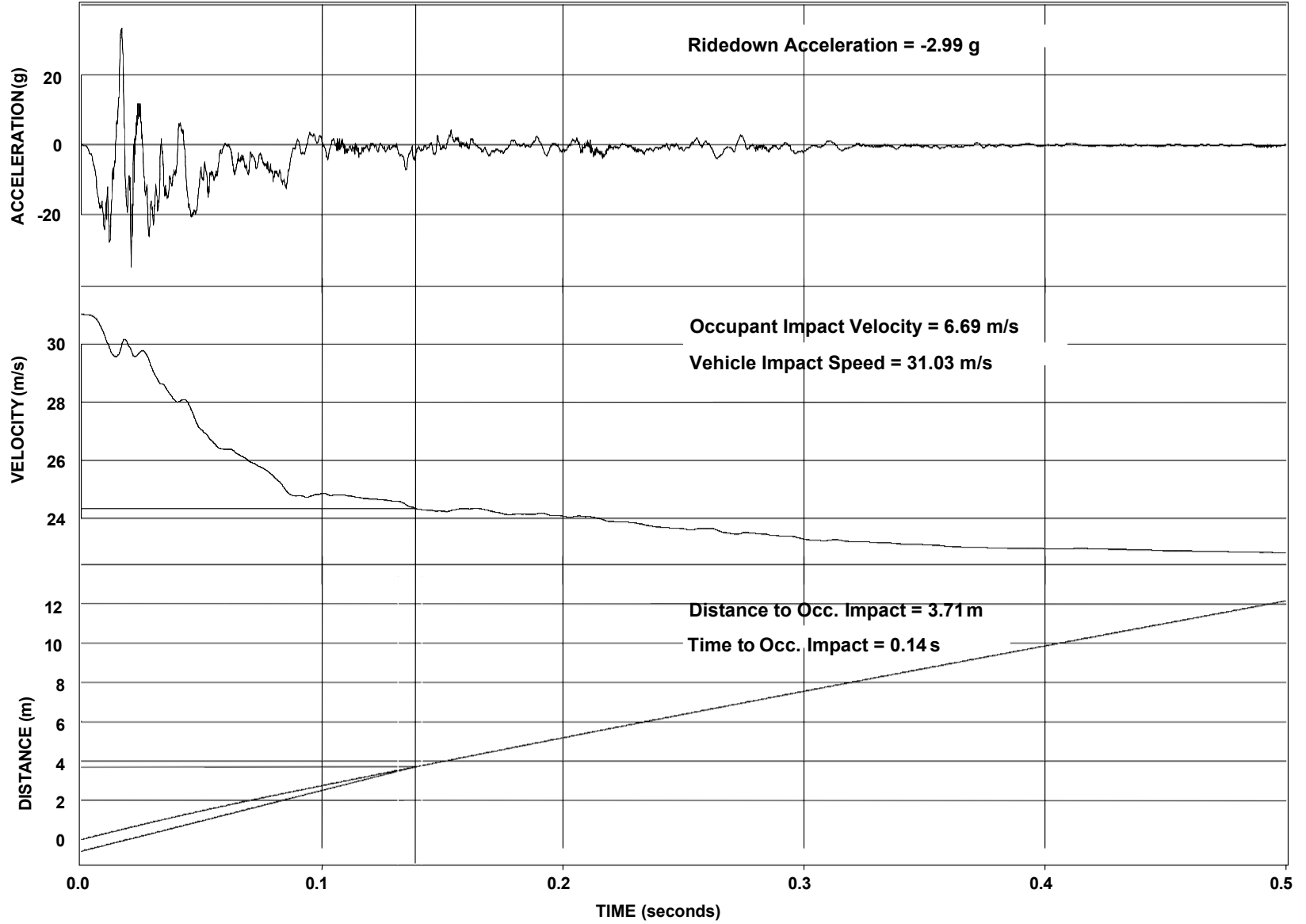
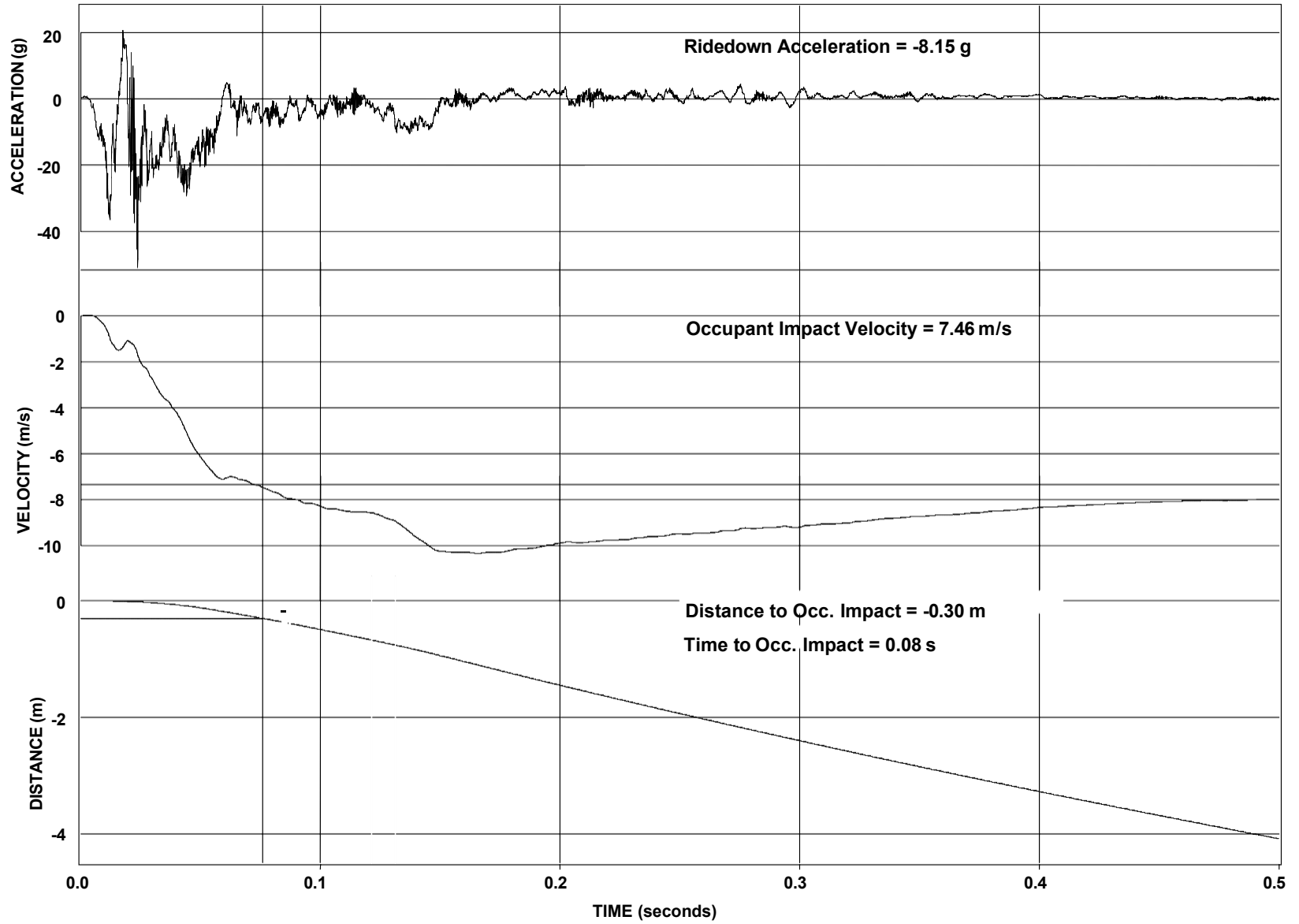
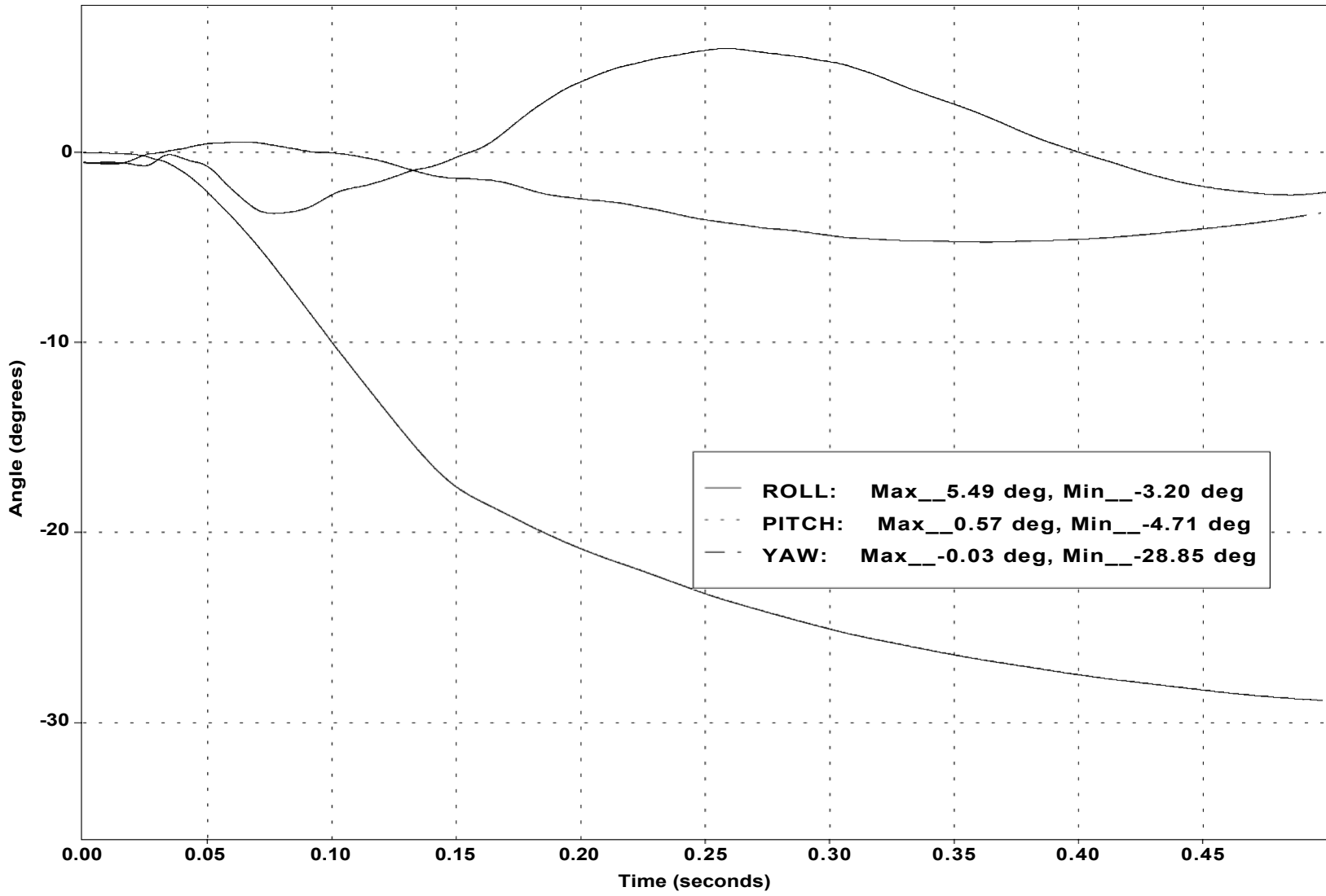

Figure 6-3 Vehicle Accelerometer Sign Convention









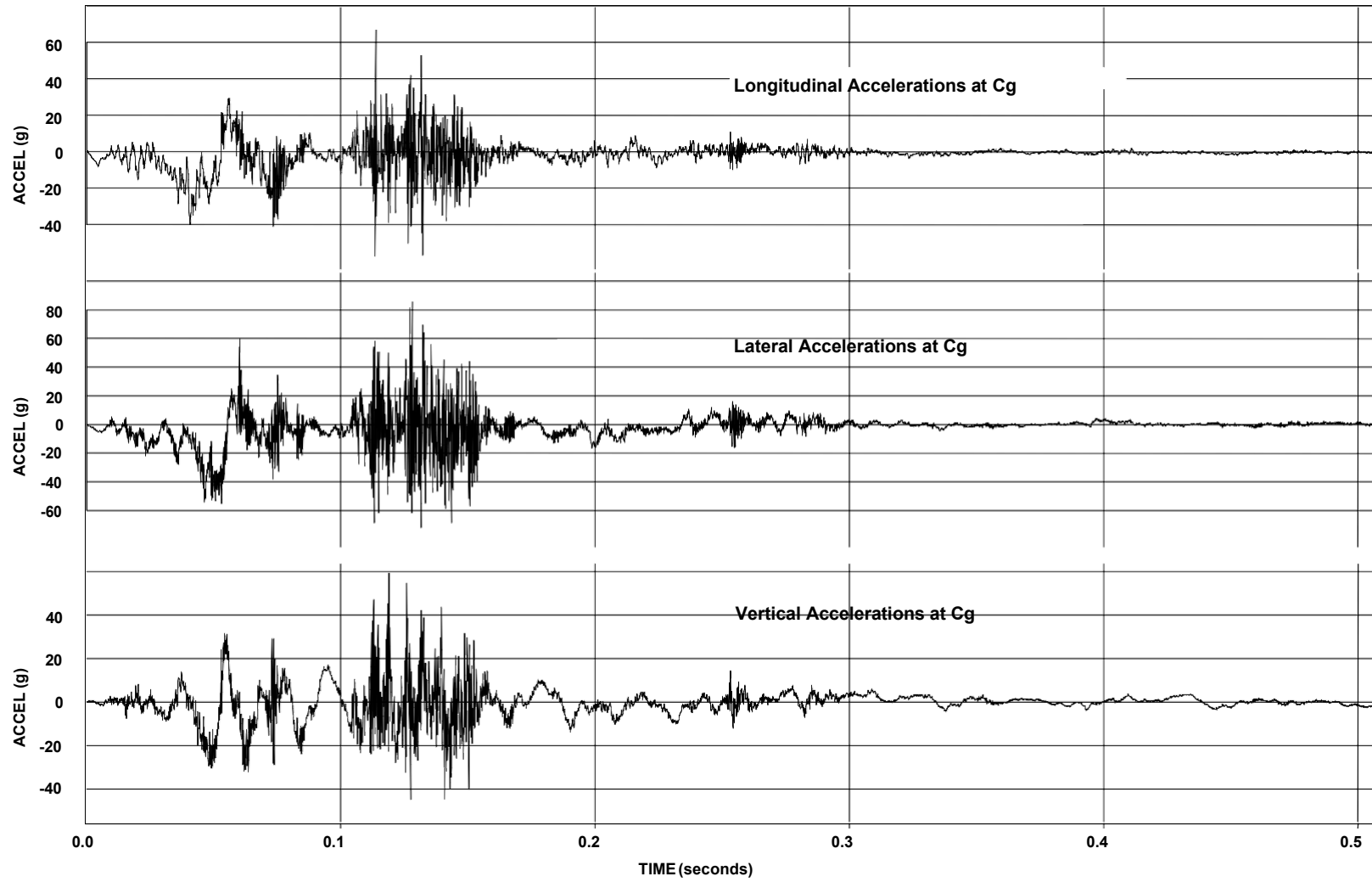

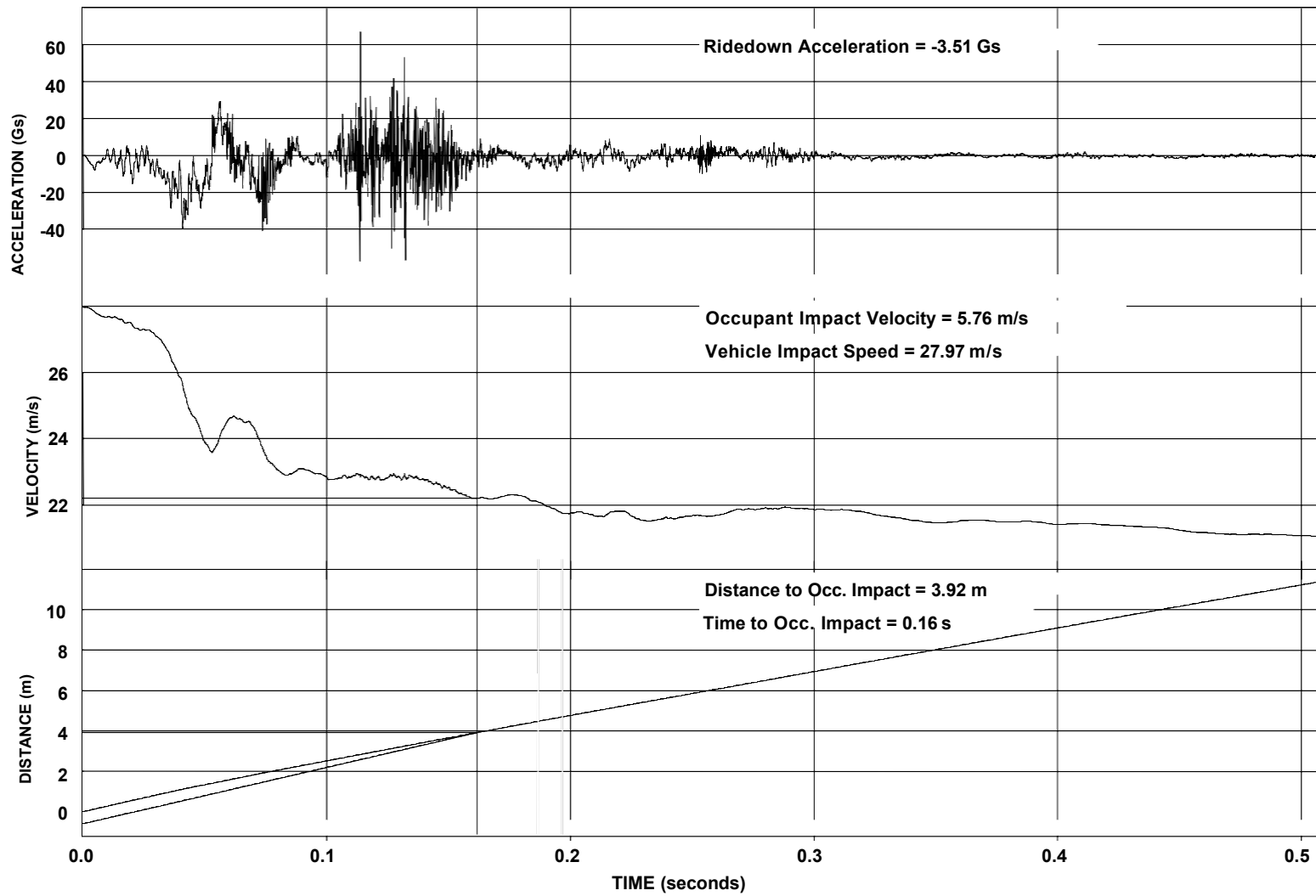

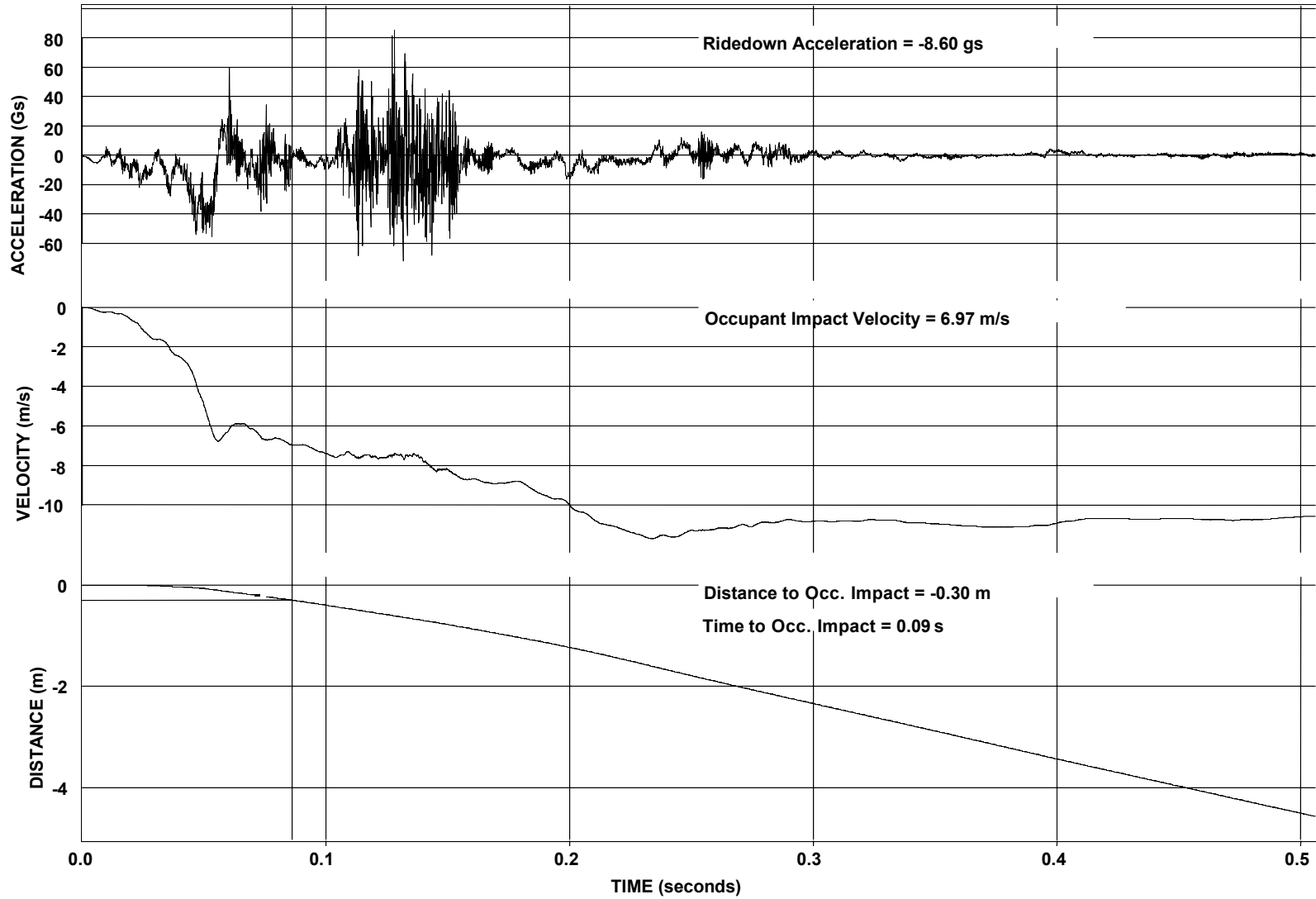

52

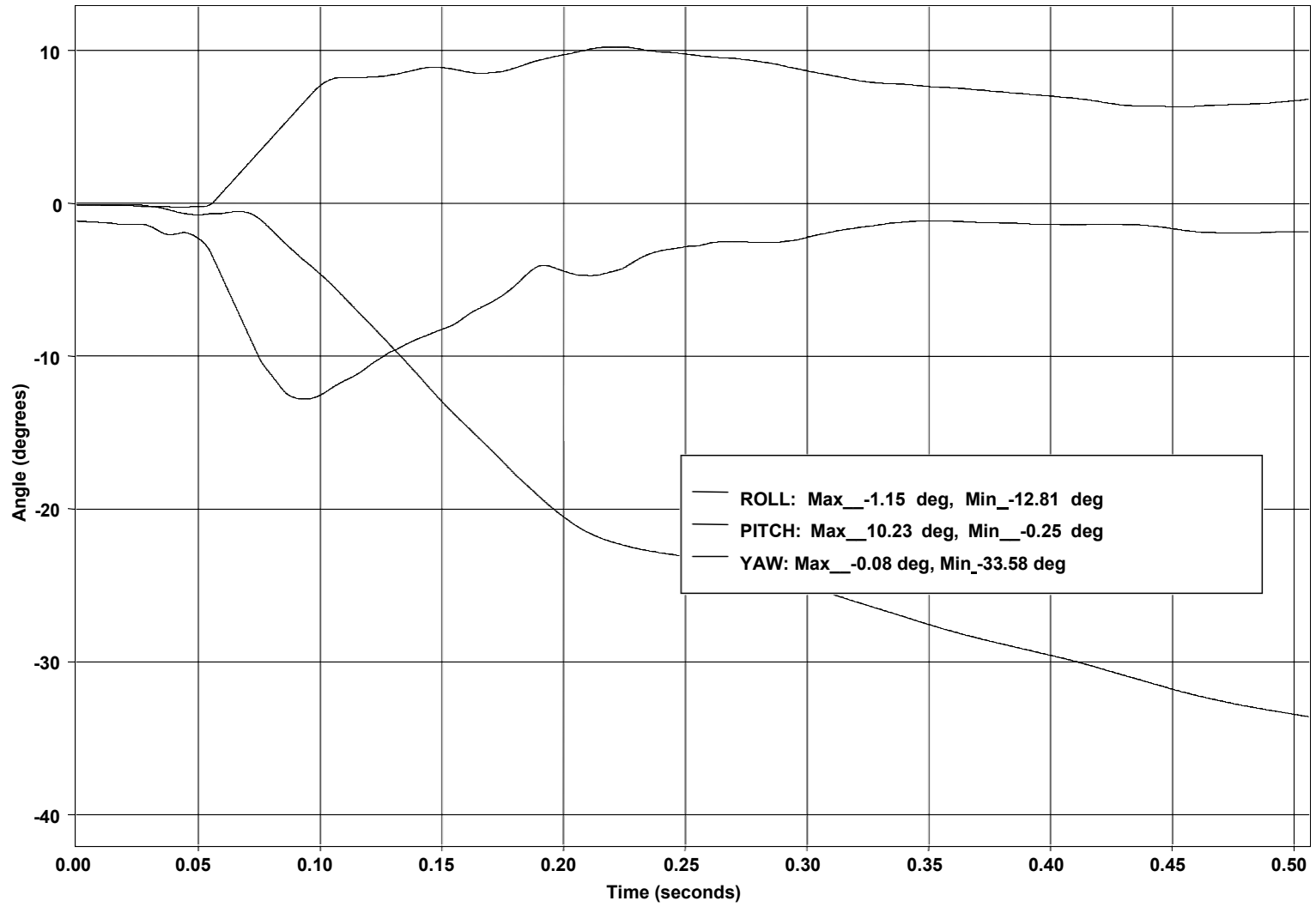

6.5. *Detailed Drawing*

(The following two 11" x 17" foldout pages contain drawings of the test article as installed and tested.)

7. REFERENCES

1. "Recommended Procedures for the Safety Performance Evaluation of Highway Features", Transportation Research Board, National Cooperative Highway Research Program Report 350, 1993.
2. "Roadside Design Guide", American Association of State Highway and Transportation Officials, 1988.
3. Jewell, John, et al., "Vehicle Crash Tests of Type 115 Barrier Rail Systems for Use on Secondary Highways", Transportation Research Record 1419, Transportation Research Board, Oct. 1993.
4. "Guide Specifications For Bridge Railings", American Association of State Highway and Transportation Officials, 1989.
5. Hirsch, T.J. et. al., "Aesthetically Pleasing Concrete Beam and Posts Bridge Rail - Texas Type T411", Texas Transportation Institute, Report No. TTI-2-5-88/89-1185-1, March 1989.
6. Hirsch, T.J. et. al., "Aesthetically Pleasing Concrete Beam-and-Post Bridge Rail", Transportation Research Record 1258, Transportation Research Board, 1990.
7. Meline, Robert et. Al., "Vehicle Crash Tests of the Aesthetic, See-Through Concrete Bridge Rail with Sidewalk, Type 80SW", California Department of Transportation, Sacramento, CA., March 1999.
8. "Development of a Comprehensive Bridge Specification and Commentary" - Section 13, National Cooperative Highway Research Program Project 12-33, 1993.
9. "Standard Specifications", California Department of Transportation, Sacramento, CA., 1995.
10. "Vehicle Damage Scale for Traffic Accident Investigators", Traffic Accident Data Project, National Safety Council, 1968.
11. "Collision Deformation Classification" - SAE J224 Mar80, SAE Recommended Practices, 1980.

U.S. Department
of Transportation
**Federal Highway
Administration**

400 Seventh St., S.W.
Washington, D.C. 20590

May 18, 1999

Refer to: HMHS

Mr. Rich Peter, Chief
Roadside Safety Technology Section
Office of Materials Engineering and
Testing Services - MS #5
5900 Folsom Boulevard
Sacramento, California 95819-0128

Dear Mr. Peter:

In your April 6 letter to Mr. Henry Rentz, you requested formal Federal Highway Administration acceptance of the California Type 80 Bridge Rail at NCHRP Report 350 test level 4 (TL-4). To support your request, you also sent a copy of your March 1999 report entitled "Vehicle Crash Tests of the Type 80 Bridge Rail" and a video tape of the three tests you conducted. Copies of these materials were also sent to Mr. Charles McDevitt for his concurrent review and comments.

The Type 80 Bridge Rail is an aesthetic concrete post and beam design incorporating a 230-mm high curb, a 280-mm clear opening, and a 300-mm deep top beam. The posts are offset 100 mm from the face of the upper beam. Enclosure 1 is a schematic drawing of the final design. Staff members have reviewed the results of the tests you conducted on the Type 80 Bridge Rail and concur with your assessment that appropriate NCHRP Report 350 evaluation criteria were met. The summary results of each test are shown in Enclosure 2. This design may be considered acceptable for use on the National Highway System as a TL-4 bridge railing.

As you recall you previously sent information to Mr. Rentz on a similar design called the Type 80SW Bridge Railing. This design was identical to the Type 80, but it was tested behind a 200-mm high curb and a 1500-mm wide sidewalk. Additionally, it had a horizontal TS 51 x 51 x 4.8 steel tube at the midpoint of the clear opening, and a TS 76 x 51 x 4.8 steel tube mounted on the top beam to raise the total height to 1060 mm. This design is shown in Enclosure 3. The Type 80SW Bridge Railing was actually tested at TL-4, but there was significant passenger compartment intrusion when this design was impacted by the 2000-kg pickup truck at 100 k/hr

2

and at an angle of 25 degrees. Summary results for all three tests are shown in Enclosure 4. My December 2, 1998 letter to you indicated that we would accept the Type 80SW Bridge Rail as a TL-2 design without additional testing, thus permitting its use on the NHS at locations where impact speeds are not expected to exceed 70 k/hr.

There is a significant interest in acceptable, aesthetic bridge railing designs nationwide. I am assuming that any agency interested in using the Type 80 or the Type 80SW designs will be able to obtain copies of detailed plans and specifications directly from your Department.

Sincerely yours,

Dwight A. Home

Dwight A. Home
Director, Office of Highway Safety
Infrastructure

4 Enclosures