

1. REPORT NUMBER CA17-2990	2. GOVERNMENT ASSOCIATION NUMBER	3. RECIPIENT'S CATALOG NUMBER
4. TITLE AND SUBTITLE Field Testing of the Snowplow Driver Assistance System		5. REPORT DATE December 14, 2016
7. AUTHOR Kin Yen, Ty Lasky, and Bahram Ravani		6. PERFORMING ORGANIZATION CODE AHMCT Research Center, UC Davis
9. PERFORMING ORGANIZATION NAME AND ADDRESS AHMCT Research Center UCD Dept. of Mechanical & Aerospace Engineering Davis, California 95616-5294		8. PERFORMING ORGANIZATION REPORT NO. UCD-ARR-16-11-23-01
12. SPONSORING AGENCY AND ADDRESS California Department of Transportation P.O. Box 942873, MS #83 Sacramento, CA 94273-0001		10. WORK UNIT NUMBER
		11. CONTRACT OR GRANT NUMBER IA65A0560, Task 2990
		13. TYPE OF REPORT AND PERIOD COVERED Final Report October 2015 – November 2016
15. SUPPLEMENTARY NOTES		14. SPONSORING AGENCY CODE Caltrans
16. ABSTRACT <p>The Advanced Highway Maintenance and Construction Technology (AHMCT) Research Center at the University of California-Davis and the Caltrans Division of Research, Innovation and System Information (DRISI) have identified an advanced snowplow guidance technology originally developed at the University of Minnesota that can enhance the safety and efficiency of snow removal operations in the Sierra Nevada mountains in California. This research was a continuation of the evaluation performed in prior research. The purpose of the current research was to evaluate the system as implemented for California operations and to provide technical support for the system. This evaluation employed ride-along observations of operators using the system in regular snowplowing operations. The evaluation also included informal interviews with the snowplow operators. The system evaluation was unfortunately limited due to significant obstacle detection radar enclosure icing issues, as well as delamination of the radar enclosure fascia. These two issues, along with limited storm events, prevented the researchers from testing the system to the extent desired. The system has been shown to work well and provide safety advantages for both lane-keeping and obstacle detection and warning. However, until the two radar issues are resolved, implementation in the snow environment will not be possible. A new radar enclosure design was developed in this research to address the two issues. However, this design has not yet been tested or implemented.</p>		
17. KEY WORDS Driver assistance system (DAS), Head-Up Display (HUD), GPS, Winter maintenance, Snow management	18. DISTRIBUTION STATEMENT No restrictions. This document is available to the public through the National Technical Information Service, Springfield, Virginia 22161.	
19. SECURITY CLASSIFICATION (of this report) Unclassified	20. NUMBER OF PAGES 36	21. COST OF REPORT CHARGED

Reproduction of completed page authorized

DISCLAIMER

The research reported herein was performed by the Advanced Highway Maintenance and Construction Technology (AHMCT) Research Center, within the Department of Mechanical and Aerospace Engineering at the University of California – Davis, for the Division of Research, Innovation and System Information (DRISI) at the California Department of Transportation. AHMCT and DRISI work collaboratively to complete valuable research for the California Department of Transportation.

The contents of this report reflect the views of the author(s) who is (are) responsible for the facts and the accuracy of the data presented herein. The contents do not necessarily reflect the official views or policies of the STATE OF CALIFORNIA or the FEDERAL HIGHWAY ADMINISTRATION. This report does not constitute a standard, specification, or regulation.

The contents of this report do not necessarily reflect the official views or policies of the University of California. This report does not constitute an endorsement of any products or services described herein.

For individuals with sensory disabilities, this document is available in Braille, large print, audiocassette, or compact disk. To obtain a copy of this document in one of these alternate formats, please contact: the Division of Research, Innovation and System Information, MS-83, California Department of Transportation, P.O. Box 942873, Sacramento, CA 94273-0001.



Advanced Highway Maintenance and Construction Technology Research Center

Department of Mechanical and Aerospace Engineering
University of California at Davis

Field Testing of the Snowplow Driver Assistance System

Kin Yen, Ty Lasky &
Bahram Ravani: Principal Investigator

Report Number: CA17-2990

AHMCT Research Report: UCD-ARR-16-11-23-01

Final Report of Contract: IA65A0560, Task 2990

December 14, 2016

California Department of Transportation

Division of Research, Innovation and System Information

ABSTRACT

The Advanced Highway Maintenance and Construction Technology (AHMCT) Research Center at the University of California-Davis and the Caltrans Division of Research, Innovation and System Information (DRISI) have identified an advanced snowplow guidance technology originally developed at the University of Minnesota that can enhance the safety and efficiency of snow removal operations in the Sierra Nevada mountains in California. This research was a continuation of the evaluation performed in prior research. The purpose of the current research was to evaluate the system as implemented for California operations and to provide technical support for the system. This evaluation employed ride-along observations of operators using the system in regular snowplowing operations. The evaluation also included informal interviews with the snowplow operators. The system evaluation was unfortunately limited due to significant obstacle detection radar enclosure icing issues, as well as delamination of the radar enclosure fascia. These two issues, along with limited storm events, prevented the researchers from testing the system to the extent desired. The system has been shown to work well and provide safety advantages for both lane-keeping and obstacle detection and warning. However, until the two radar issues are resolved, implementation in the snow environment will not be possible. A new radar enclosure design was developed in this research to address the two issues. However, this design has not yet been tested or implemented.

TABLE OF CONTENTS

<i>Abstract</i>	<i>ii</i>
<i>Table of Contents</i>	<i>iii</i>
<i>List of Figures</i>	<i>iv</i>
<i>List of Tables</i>	<i>v</i>
<i>List of Acronyms and Abbreviations</i>	<i>vi</i>
<i>Acknowledgments</i>	<i>vii</i>
<i>Executive Summary</i>	<i>viii</i>
Research Objectives and Methodology	viii
Results and Recommendations	ix
<i>Chapter 1: Introduction</i>	<i>1</i>
Problem	1
Objective	2
Scope of Work	2
DAS Vendor Status	2
<i>Chapter 2: Maintenance and Repair Issues Encountered During DAS Field Testing</i>	<i>4</i>
DAS Support and Maintenance Activities	4
Repairs Made	5
<i>Chapter 3: Radar Enclosure Icing and Delamination Problems and Mitigation</i>	<i>7</i>
Problem	7
Second-Generation Solution Concept	13
<i>Chapter 4: GPS HUD-Based DAS Implementation Considerations</i>	<i>16</i>
DAS Implementation on Snow Blowers	16
Prerequisite Conditions for DAS Implementation on Snowplows	16
Policy Impact	19
Budgeting for the DAS	19
Stakeholder Roles and Responsibilities	19
<i>Chapter 5: Conclusions and Future Research</i>	<i>21</i>
Research Findings Summary	21
Future Work and Recommendations	21
Go/No Go Decisions	22
<i>References</i>	<i>24</i>

LIST OF FIGURES

Figure 1.1: Snowplow Driver Assistance System installed on Caltrans snow blower (yellow) and snowplow (white).....	1
Figure 2.1: The 0024 snowplow combiner before cleaning	4
Figure 2.2: The 0506 seat vibration motors.....	6
Figure 3.1: Heated enclosure ver. 1.1. Adhesive failure causing delamination between the aluminum enclosure and the Delrin fascia	10
Figure 3.2: Heated enclosure ver. 1.2. AHMCT added mechanical fasteners to prevent delamination in the event of adhesive failure between the aluminum enclosure and the Delrin fascia.....	11
Figure 3.3: Heated enclosure ver. 1.1. Foam insulation added to reduce heat loss at the back of the fascia heater.....	11
Figure 3.4: SolidWorks model of radar enclosure icing mitigation system ver. 2.0 with heated fascia	14
Figure 4.1: CSDS RTN 2014 coverage.....	18

LIST OF TABLES

Table 3.1: Radar enclosure icing mitigation versions and history	8
Table 4.1: Comparison between GNSS network and dedicated GNSS base station.....	18
Table 4.2: DAS implementation budget items.....	19
Table 4.3: DAS implementation stakeholders and their roles and responsibilities.....	20

LIST OF ACRONYMS AND ABBREVIATIONS

Acronym	Definition
AHMCT	Advanced Highway Maintenance and Construction Technology Research Center
CAD	Computer-Aided Design
Caltrans	California Department of Transportation
COTS	Commercial Off-The-Shelf
CSDS	California Surveying and Drafting Supply
CVSRN	Central Valley Spatial Reference Network
DAS	Driver Assistance System
DOE	Division of Equipment
DOT	Department of Transportation
DGPS	Differential GPS
DLI	Donner Lake Interchange
DRISI	Caltrans Division of Research, Innovation and System Information
DOE	Division of Equipment
ESR	Electronically Scanning Radar
FCC	Federal Communications Commission
GHz	Gigahertz
GPS	Global Positioning System
GNSS	Global Navigation Satellite System
HUD	Head-Up Display
I-80	Interstate 80
LCD	Liquid Crystal Display
LR	Local Request
LTE	Long-Term Evolution
mph	miles per hour
PM	Project Management
PMO	Project Management Office
RADAR	RADio Detection And Ranging
RF	Radio Frequency
ROI	Return On Investment
RTK	Real-Time Kinematic
RTN	Real-Time Network
SDSRN	San Diego Spatial Reference Network
SLA	Service Level Agreement
SR	State Route
UMN	University of Minnesota
Ver.	Version

ACKNOWLEDGMENTS

The authors thank the California Department of Transportation (Caltrans) for their support, in particular Bryan Carlson, Dave Wood, David McIntire, Stan Richins, Mike Shandrew, David Frame, Herby Lissade, and Tony Tavares with the Division of Maintenance, and Justin Unck and Larry Baumeister with the Division of Research, Innovation and System Information. We also thank Larry Orcutt and his skilled staff at the Caltrans Division of Equipment for their active and excellent support on the driver assistance system (DAS) snowplows' maintenance and repair. Their work is instrumental to the safe, successful, and continuous operation of the DAS snowplows.

The authors also thank everyone from AutonomouStuff for their valuable assistance with radar enclosure icing issues, including providing spare parts. We also acknowledge Craig Shankwitz and Bryan Newstrom of MTS for their excellent system design, integration, teamwork, and support. The authors acknowledge the dedicated efforts of the AHMCT team who have made this work possible. Finally, our researchers express special thanks to the kitchen staff and snowfighter crews at the Kingvale maintenance station.

EXECUTIVE SUMMARY

The AHMCT Research Center and the Caltrans Division of Research, Innovation and System Information (DRISI) have identified an advanced snowplow guidance technology originally developed at the University of Minnesota that can enhance the safety and efficiency of snow removal operations in the Sierra Nevada mountains in California. This research is a continuation of the evaluation performed in prior research, as described in “Evaluation of the University of Minnesota GPS Snowplow Driver Assistance System.” [1] This additional evaluation was for one snow season, specifically the winter of 2015-2016. This research was intended to evaluate the system as implemented for California operations and to provide technical support for the system. The driver assistance systems (DASs) were installed on two snowplows and one snow blower in the prior research. The DAS encountered radar icing during heavy snowstorms, causing the radar to malfunction. Significant effort and time was spent in the continued development and testing of radar enclosure icing mitigation solutions. A feasible solution was developed and tested towards the end of the project, but will require additional development and testing to confirm suitability. Meanwhile, snowplow operator feedback was limited due to the ongoing radar enclosure icing problem.

The ultimate goal of this research is to support Caltrans in establishing a means to procure and use a field-ready GPS-based DAS using a head-up display (HUD) for Caltrans snowplow and snow blower operations in whiteout conditions. The current research’s support for Caltrans’ field testing of the DAS was a key step in this process.

Research Objectives and Methodology

The primary goal of this research was to spend one additional winter evaluating the readiness and fitness of the DAS for use in Caltrans winter maintenance. To achieve this goal, three primary tasks were planned:

- Perform extensive field testing of the DAS in two Caltrans snowplows and one Caltrans snow blower. All vehicles were based in the Kingvale maintenance yard on Interstate 80 in the Sierra Nevada mountains.
- Provide necessary technical support including minor system repairs and troubleshooting for the field testing. For more significant issues, act as a liaison and local support for MTS, the system provider, to diagnose and repair.
- Elicit feedback from the snowplow operators through formal surveys as well as interviews and discussions during ride-alongs.

Due to the substantial issues of radar enclosure icing and radar enclosure delamination, discussed in detail in Chapter 3, the research evolved towards investigating methods to mitigate these two issues in order to make the system viable for testing. AHMCT made substantial steps in this direction; however, the problems could not be overcome within the scope of this effort, and the system was thus not fully field tested as originally planned. As the operators were not able to test the system as intended, formal surveys were not performed. Informal feedback was obtained during ride-alongs throughout the project.

Results and Recommendations

The system as delivered at the outset of the project cannot meet Caltrans' needs for a snowplow DAS. The radar is rendered unreliable by the snow and ice buildup. The radar enclosure delamination introduces additional system reliability concerns. Without a reliable radar to provide collision warning, no component of the DAS can be used in whiteout conditions. Use of the DAS lane-keeping component without collision warning is not a suitable use of the system and is not recommended.

Several attempts were made to mitigate these issues. Some success was found addressing the snow and ice buildup, as discussed in Chapter 3. However, the issue has not been fully mitigated and remains a concern. An attempt was made to mitigate the enclosure delamination issue. This attempt may be successful, but needs further testing. In addition, the enclosure used in this mitigation attempt is not commercially available. As such, even if this approach proves successful, a feasible means of providing this enclosure to Caltrans must be found.

Further investigation of ways to mitigate the two radar issues is recommended. Additional design efforts are required to prevent the snow and ice buildup on the radar enclosure, and further testing must also be performed on the enclosure with respect to the delamination issue. When an enclosure has been designed, tested, and found satisfactory, a vendor must be found that is willing and able to produce the design. Deciding whether to address the two radar issues is the key step in deciding whether to pursue implementation of the DAS for snowplows.

While the issues noted above make it infeasible to use the DAS in winter storm whiteout conditions, the system is fully capable of supporting driver assistance in other above-freezing, low-visibility environments that are not subject to these same problems. One such application is as a DAS for tow truck operators working in dense fog—e.g., in the San Francisco Bay Area on the San Francisco–Oakland Bay Bridge. The Bay Area Emergency Response manager has expressed interest in evaluating this technology to assist in clearing accidents on Bay Area bridges. The DAS may reduce the response time to accident sites in dense fog.

CHAPTER 1: INTRODUCTION

Problem

Snow removal operations during a whiteout snowstorm are one of the most difficult tasks that winter maintenance personnel face. Researchers at the University of Minnesota and the Advanced Highway Maintenance and Construction Technology (AHMCT) Research Center, along with our research partners at the California Department of Transportation (DOT) (Caltrans), have long considered the benefits of providing driver guidance information to enhance winter maintenance activities. The University of Minnesota developed an innovative driver assistance system (DAS) for snowplows using the Global Positioning System (GPS), an automotive radio detection and ranging (radar or RADAR) system, a novel Head-Up Display (HUD), and a haptic feedback seat system using vibrating motors. They have installed and successfully tested systems on snowplows in Minnesota and Alaska. MTS, a Minnesota company, licensed the DAS from the University of Minnesota and has installed the DAS snowplow driver assistance system on two snowplows and one snow blower based at the Caltrans Kingvale maintenance facility next to Interstate 80 (I-80) (see Figure 1.1).



Figure 1.1: Snowplow Driver Assistance System installed on Caltrans snow blower (yellow) and snowplow (white)

The DAS is based on dual-frequency, carrier-phase, real-time kinematic (RTK) differential GPS (DGPS). This DGPS system allows the vehicle position to be determined with accuracy better than 8 cm at a data rate of 10 Hz. Along with the DGPS, the DAS incorporates a high-accuracy geospatial database, a forward-looking radar for obstacle detection, and a comprehensive driver interface consisting of both graphical displays and tactile feedback. The graphical displays include a HUD that enables an operator to “see” road lanes and lane boundaries in low visibility and a touchscreen-based system information/control panel. The tactile interface consists of a vibrating

seat that indicates lane departure situations by vibrating the seat bottom on the side where the lane departure is imminent [1-11].

In a previous research project ending August 2015, AHMCT worked with the University of Minnesota and MTS to instrument two snowplows and one snow blower with DASs. AHMCT supported, tested, and evaluated these systems in the winters of 2011-12 through 2014-15 [1]. Due to the mild nature of these winters and a radar enclosure icing problem, the DASs need further extended field testing, including additional operator training, in order to verify that the systems are ready for regular Caltrans use and to identify any deficiencies. Researcher support is needed for the field testing and to address any deficiencies identified in the DAS. The reader may wish to refer to the previous research report [1] for a broader view and additional system details.

Objective

The ultimate research goal is to support Caltrans in establishing a means to procure and use a field-ready GPS HUD-based DAS for Caltrans snowplow and snow blower operations in whiteout conditions. The current research's support for Caltrans' field testing of the DAS was a key step in this process.

Scope of Work

The proposed research provided support for extended Caltrans district field testing of the GPS HUD-based snowplow driver assistance system. The proposal tasks included:

- Support driver assistance system field testing in District 3, Kingvale maintenance yard. This includes operator training for the snowplow DAS and the snow blower DAS.
- Repair driver assistance system hardware as needed based on issues identified in field testing.
- Document driver assistance system changes implemented during the research.

The proposal included a component to identify deficiencies from ride-alongs and operator feedback. This was to be obtained through formal survey. AHMCT did perform ride-alongs and did receive informal feedback from the operators. This feedback was generally quite positive. However, due to the radar enclosure icing issues noted in detail in Chapter 3 and their impact on the ability of operators to perform detailed testing of the DAS, formal survey and related feedback could not be performed.

DAS Vendor Status

The specific DAS tested in this and the previous research is provided by a single vendor. There is no alternative vendor at the time of this report. Thus, the status of this vendor is a critical factor in considering implementation of the DAS within Caltrans.

The DAS vendor, MTS Systems,¹ is a fairly large company focusing on sensing and testing. The GPS HUD-based DAS technology was originally developed by a research group at the University of Minnesota (UMN). Two core members of this UMN research group throughout the DAS research and development subsequently joined MTS when MTS acquired a license for the GPS HUD-based DAS technology. The two core UMN research group members became the founding members of MTS' team dedicated to developing the GPS HUD-based DAS technology. This is a small team and a small product area within the MTS portfolio.

MTS recently added a staff member to the DAS team for business development and marketing. The team also added another individual for additional technical development. Important developments occurred in the late spring of 2016:

- The MTS team technical lead left MTS, effective June 24, 2016.
- As of early December 2016, the programmer was still with MTS.

Based on the issues noted in Chapter 3, AHMCT had been in discussions with MTS to have them do a radar enclosure redesign to address icing and delamination issues. With the above changes at MTS, the redesign did not progress.

Considering these developments, MTS' level of commitment to and the further development of the DAS product seem uncertain. Caltrans should consider these developments as they contemplate any larger-scale implementation of the DAS.

¹ <http://www.mts.com/>

CHAPTER 2: MAINTENANCE AND REPAIR ISSUES ENCOUNTERED DURING DAS FIELD TESTING

In this chapter and throughout the report, the three DAS-instrumented vehicles are typically referenced by a shortened version of their full Caltrans ID number. The snow blower ID is 7005039; it is typically just referred to as the snow blower. The snowplow IDs are 0530506 and 7000024. These are referred to, respectively, as 0506 and 0024.

In this chapter, we detail the main maintenance and repair issues encountered during the DAS field testing. These issues are important, as they provide Caltrans with an idea of the types of problems they will likely encounter on a somewhat regular basis with a full DAS implementation. They also indicate the routine maintenance that would be required to keep the system operational.

DAS Support and Maintenance Activities

- The combiner of the snow blower and the 0506 and 0024 snowplows were cleaned carefully to avoid scratching the semi-reflective surface before the winter session began (10/15/2015). Since the 0024 snowplow was used to haul sand and dirt when there were no storms, the 0024 combiner was quite dirty compared to the combiner in the 0506 snowplow.



Figure 2.1: The 0024 snowplow combiner before cleaning

- DRISI expressed concern about the combiner sensitivity to dirt and dust, and the difficulty of cleaning. They asked about possibilities for putting a protective film on during the summer and perhaps the winter. The suggestion was to switch the film between seasons or remove it before winter if the film impacts the optics. They suggested something with static, non-adhesive application. AHMCT researchers were concerned that the plastic film might interact with the delicate semi-reflective coating. Pursuit of this idea by MTS would be best since the film would be an add-on to their commercial system.

- MTS provided a zip-lock bag to cover the combiner in summer, but this approach did not work well. The zip-lock bag tended to rub on the combiner with dirt between the combiner and plastic bag, causing scratches on the combiner.
- AHMCT recommends taking the combiners off during the summer, keeping them in safe storage, and reinstalling them before winter. They should not be exposed to the harsh and dirty conditions of Caltrans summer operations.
- All wireless modems were reactivated from “suspend” status so that the Global Navigation Satellite System (GNSS) differential station corrections data could be communicated to the GPS rover receivers on-board the snowplows and snow blower. This station is located at Kingvale.
- The DASs on the snowplows and snow blower were operationally tested to confirm that they functioned properly on 12/14/2015.
- AHMCT tested components before the winter snow session began (10/15/2015):
 - Checked if the Liquid Crystal Display (LCD) worked
 - Checked if the DGPS system worked
 - Checked if radar detected targets
 - Visually inspected the system components for physical damage
 - Note that full system testing requires a Caltrans operator driving the vehicle on the roadway. This testing is not usually performed before the season begins due to the lack of operators at the Kingvale yard in the off-season.
- Caltrans operators were trained to use the system during ride-alongs. This could only be done if road and weather conditions permitted.

Repairs Made

1. The GNSS receiver in the 0506 snowplow was found to be non-functional on 04/13/2016. The GNSS receiver showed zero satellites after 4 to 5 minutes of clear exposure to the sky (satellites). The system and the GNSS receiver were rebooted three times. The snow accumulation on the GNSS antenna was cleared off. Note that the snow and ice accumulation on the GNSS antenna never caused problems with GNSS signal reception; this was just a precautionary step. The electrical connections between the antenna and GNSS receiver were checked. A spare GNSS antenna and cable were needed to further diagnose the problem, but these were not carried in the repair tool kit since the focus of the ride-along was radar testing on that day. GNSS positioning failures are rare; this was the only time that such a failure was observed in this or the prior project. Without GNSS position data, the researchers relied on the system display’s indicator to determine the radar’s functioning. The GNSS antenna cable was

- later found to be the cause of the problem. The broken antenna cable did not show signs of physical damage. There was some oxidation on the connector that is exposed to the elements. The cable was commercially made with rubber vulcanization on the back end of the connector to provide waterproofing and strain relief. This antenna cable was replaced, restoring function to the GNSS receiver.
2. A new system power switch was installed on the 0024 snowplow to replace a broken snowplow DAS power switch.
 3. The DAS seat vibration motors were left on the floor of the 0506 snowplow (see Figure 2.2) on 04/05/2016 when the driver seat was replaced. The seat vibration motors need to be reinstalled into the new seat. However, the 0506 snowplow may be retired soon, possibly during summer 2017. The seat vibration motor installation procedure documentation was requested and received from MTS. Some wiring work would be required to add connectors to aid future driver seat maintenance. The vibration motors are currently secured next to the center console of the 0506 snowplow.
 4. The modified heated radar enclosures and wipers were reinstalled 04/05/2016 on snowplows 0506 and 0024. See Chapter 3 for details.



Figure 2.2: The 0506 seat vibration motors

CHAPTER 3: RADAR ENCLOSURE ICING AND DELAMINATION PROBLEMS AND MITIGATION

In the previous research as well as the field testing of the current research, significant issues were encountered with the radar component of the DAS. The primary issues were ice buildup on the radar enclosure fascia and delamination of the fascia from the radar enclosure. The radar enclosure houses the Electronically Scanning Radar (ESR). The ice buildup is a serious problem, as it prevents proper detection of obstacles by the radar. Without this detection, the DAS cannot provide collision warning. As such, the system cannot be used at all during a whiteout situation, as it is not recommended to provide lane position guidance without collision warning. The enclosure delamination issue can lead to the exposure of the internals to water accumulation, which would prevent proper radar function. Note that the commercial off-the-shelf (COTS) ESR unit is environmentally sealed, but the MTS system design has the ESR unit housed within the radar enclosure. It is also essential to note that the ice buildup problem encountered in this research appears to be limited to California; other areas where this DAS has been tested, including Minnesota and Alaska, have not encountered this problem. The issue seems to be uniquely related to the environmental conditions encountered during snow removal on Interstate 80 in California and any similar environments. Additional details regarding radar enclosure icing and delamination problems, along with attempts to mitigate them, are provided in this chapter. The two issues are considered together in a coordinated fashion because they are related, and an integrated design must address both. The scope of this research was to evaluate the DAS, but the development and testing of the radar system issues went above and beyond this scope. However, both were done in an effort to further facilitate DAS field testing and future implementation.

Problem

During initial snowplow DAS testing in the previous research [1], there was occasional ice buildup on the front fascia of the enclosure for the ESR made by Delphi Automotive PLC. This ice and water layer attenuated radar signal (sending and receiving). The thin water layer trapped in the wet snow affixed on the radar enclosure fascia absorbed a majority of the 76 GHz radio signal emitted from the ESR and rendered the radar ineffective. The water layer buildup and signal attenuation problem was not reported by Alaska or Minnesota during their use of similar systems and therefore has been attributed to the type of snow prevalent in the Sierras. The phenomenon was new to and unexpected by University of Minnesota, MTS, and AHMCT researchers. AHMCT researchers had previously used COTS radars for snowplow DASs in other projects [12-14]. There was ice buildup on the Eaton Vorad EVT300 radar used, but it did not cause any radar performance degradation. However, the previously-used radar is currently out of production and employed 24 GHz radio frequency (RF) for object detection. The ice/water RF signal attenuation for a 24 GHz signal is smaller than for the 76 GHz signal used by Delphi ESR. The Federal Communications Commission (FCC) dedicated 76 GHz for automotive collision warning radar use. Therefore, most current COTS automotive radars available in U.S. utilize a 76 GHz RF. Significant effort was made by AHMCT researchers to resolve the radar enclosure icing issue, as it must be resolved before the operational testing and evaluation of the snowplow DAS can begin in earnest. The first-generation icing mitigation solution is detailed in Chapter 4 of the prior research final report [1].

While icing was a significant issue for the snowplow DAS radar enclosure, this issue was not observed on the snow blower DAS radar enclosure. The snow blower DAS testing was minimal due to the light winter during this and the prior research. However, in this testing, no radar enclosure icing was observed. In addition, when the snowplow DAS vehicles were idling in the maintenance yard during heavy wind and snowfall, they did not experience icing. As the environmental conditions while idling are fairly comparable to those in the extremely low-speed snow blower operation, it is reasonable to conclude that the snow blower radar enclosure will not experience icing in normal operation. On a perhaps related note, the snow blower radar fascia did not experience delamination during this research.

Previous Radar Enclosure Icing Mitigation Versions and Repairs Made

The history of radar enclosure icing mitigation versions is summarized in Table 3.1. This table lists various radar enclosure icing mitigation names, descriptions, and their test periods and results in the previous and current research. This table is meant to facilitate clarity and understanding in reviewing the accompanying text, and should be consulted as a reference as needed. If versions are not noted in the table (e.g. version 1.3), those versions were not viable and are hence irrelevant here. In addition, versions are not always chronological; instead, they are grouped and ordered based on the mitigation methods included. It is important to note that the DAS evaluation of this current research was for only one snow season, the winter of 2015-2016.

Table 3.1: Radar enclosure icing mitigation versions and history

Name used in this report	Description	Testing period	Test Result
Heated enclosure version (ver.) 1.0	<ul style="list-style-type: none"> • Heated ESR sealed enclosure made by AutonomouStuff. • It has a temperature controller to prevent overheating the ESR radar. • This enclosure is no longer available. 	Feb 2013 (previous research)	<ul style="list-style-type: none"> • Failed to prevent radar enclosure icing on its own.
Heated enclosure ver. 1.1	<ul style="list-style-type: none"> • Heated enclosure ver. 1.0 with added insulation on the back of the heating element inside the enclosure (see Figure 3.3). • Heater power output limited by the resistors, heater controller, and overheating of the ESR housed inside. 	March 2013 (previous research)	<ul style="list-style-type: none"> • Able to prevent icing when vehicle is not moving. • Failed to prevent icing on its own when vehicle is moving. • Epoxy adhesive failed.
Heated enclosure ver. 1.2	<ul style="list-style-type: none"> • Heated enclosure ver. 1.1 with added fasteners to Delrin front fascia to prevent delamination. (see Figure 3.2) • Water drain hole added at the bottom of the enclosure. 	April 2016 (this research)	<ul style="list-style-type: none"> • Able to prevent icing when vehicle is not moving. • Failed to prevent icing on its own when vehicle is moving.

Radar enclosure icing mitigation system ver. 1.4	Heated enclosure ver. 1.1 with heated wiper blade and marine grade wiper motor.	April 2014 to March 2015 (previous research)	<ul style="list-style-type: none"> Prevented radar enclosure icing in light to heavy snowfall up to 30 miles per hour (mph).
Radar enclosure icing mitigation system ver. 1.5	Heated enclosure ver. 1.2 with heated wiper blade and marine grade wiper motor	March to April 2016 (this research)	<ul style="list-style-type: none"> Prevented radar enclosure icing in light to medium snowfall up to 35 mph. Failed to prevent ice in heavy snowfall with vehicle speed above 30 mph
Radar enclosure icing mitigation system ver. 2.0	<ul style="list-style-type: none"> Heated wiper blade and marine grade wiper motor (same as radar enclosure icing mitigation system ver. 1.5) with different heated front Teflon fascia design. Higher heater power output. Reduced frontal area. ESR is not enclosed to avoid overheating by the Teflon front fascia heater. 	Designed in this research. Not tested.	None

The Delphi ESR radar dealer (www.AutonomouStuff.com) developed the heated enclosure ver. 1.0 for the ESR used on the DAS. Again, refer to Table 3.1 for an overview of the mitigations, version numbers, and test periods and results. The heated enclosure ver. 1.0 consists of a hydrophobic plastic (Delrin²) front fascia, shown in white in Figure 3.1. Epoxy adhesive was used to affix the Delrin front fascia to the aluminum housing. After one year of operation in the field, the epoxy adhesive failed, and the Delrin front fascia delaminated from the aluminum enclosure, as shown in Figure 3.1. This failure hindered the operation of the mechanical wiper of the radar enclosure icing mitigation system ver. 1.4. The failure of the epoxy adhesive occurred in December 2015 during the current research; it was not observed in the prior research testing. The delamination was identified during ride-along testing in the first major snowstorm of winter 2015.

A teleconference was held to solicit AutonomouStuff’s support for the development of the next generation of their heated enclosure for the ESR. However, AutonomouStuff, the sole distributor of the Delphi ESR radar and the original maker of the heated enclosure ver. 1.0, had decided to discontinue the heated enclosure ver. 1.0 and any future development of radar heated enclosures for the DAS. AutonomouStuff sent AHMCT the remaining spare parts of the heated enclosure ver. 1.0 in their inventory for free in March 2016 in order for AHMCT to repair the system quickly and continue the DAS evaluation and testing. Consequently, once all the spare parts of the heated enclosure ver. 1.0 have been consumed by corrosion or other failures, there will be no replacements. As shown in Figure 3.2, AHMCT added mechanical fasteners to prevent the

² Delrin, http://www.dupont.com/products-and-services/plastics-polymers-resins/thermoplastics/brands/delrin-acetal-resin.html?src=gg-kg_dpm-na-delrin_delrin-EX

delamination of the front fascia of the heated enclosure ver. 1.0 from interfering with the heated wiper operation. The radar enclosure icing mitigation system ver. 1.5 was installed on both the 0024 and 0506 snowplows on 04/05/2016. Previous test results show that the heated enclosure ver. 1.2 will eventually fail due to delamination since the design did not change from that of the previous enclosure which did delaminate. Any new radar enclosure icing mitigation system should be designed so that it does not have any epoxy joints or metal that can corrode. The solution to this problem is to design away from any adhesive joint and non-anodized aluminum. AutonomouStuff currently provides sealed (non-heated) enclosures for ESRs used in the mining industry. Their new sealed enclosures for the mining industry use rubber gasket and mechanical fasteners to secure the front fascia onto the aluminum housing. The snowplow DAS does not require the factory-sealed ESR to be housed inside any sealed enclosure since the ESR is already sealed. The AutonomouStuff heated enclosure happens to be sealed.



Figure 3.1: Heated enclosure ver. 1.1. Adhesive failure causing delamination between the aluminum enclosure and the Delrin fascia



Figure 3.2: Heated enclosure ver. 1.2. AHMCT added mechanical fasteners to prevent delamination in the event of adhesive failure between the aluminum enclosure and the Delrin fascia

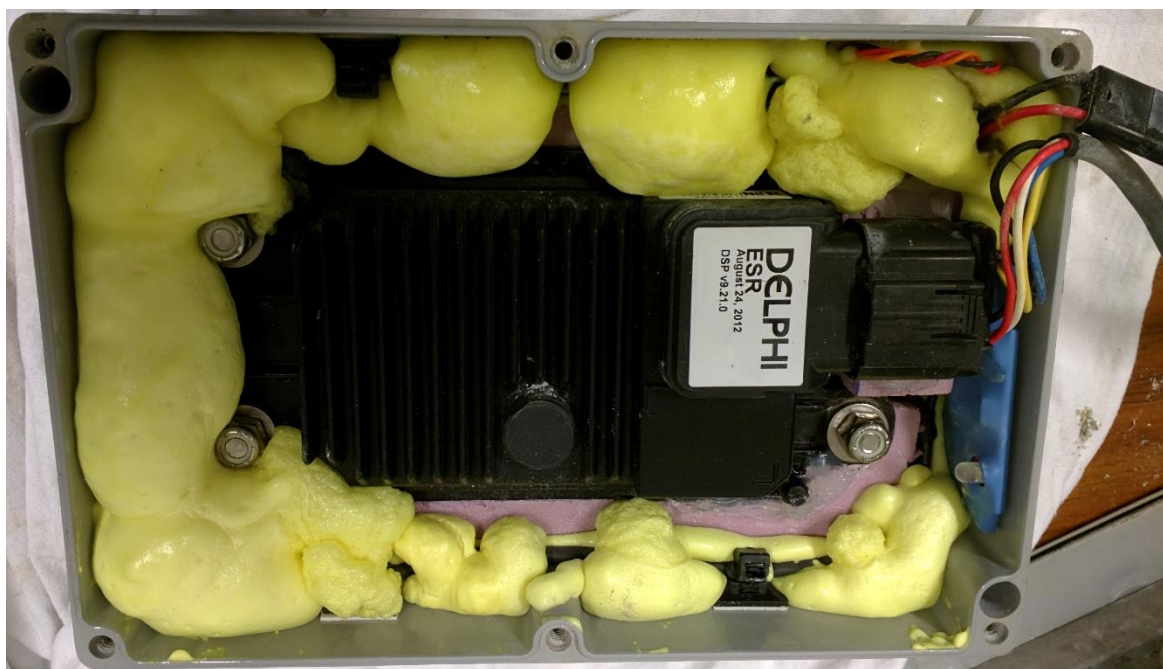

Figure 3.3: Heated enclosure ver. 1.1. Foam insulation added to reduce heat loss at the back of the fascia heater

Testing of the radar enclosure icing mitigation ver. 1.5 was performed in Spring 2016. A major snowstorm started at about 3 am on 04/14/2016. The snowfall was very heavy from 3:30 am to 4:30 am. It was estimated to be about 6" to 8" on Interstate 80 at Kingvale by checking the snow accumulation on the ground in the Kingvale maintenance yard. Chain control was up at Nyack first and was quickly moved down to Drum Forebay Road at around 3:15 am. The air temperature was 28 to 32 degree Fahrenheit (F). The 0506 snowplow was the lead plow plowing from Kingvale

to State Route 20 (SR 20) throughout the shift. Whiteout conditions were experienced driving westbound toward the SR 20 intersection. Chain control was lifted at around 8 am.

During the 04/14/2016 snowstorm, the radar enclosure icing mitigation system ver. 1.5 on the 0506 snowplow was tested. The 0506 snowplow heated enclosure (ver. 1.2) fascia had a thin layer of ice buildup from driving in the snowstorm before coming into the yard to put on chains. In the beginning, the radar seemed functional from reading the display indicator. The radar seemed to fail, however, after driving a few miles in the heavy snowstorm going westbound on I-80. The radar seemed to function again going eastbound on I-80. Typically, the wind is blowing eastward. Traveling westbound would go against the wind direction, therefore resulting in higher snow load on the radar and higher likelihood of whiteout. From this test, the heated enclosure (again, the ver. 1.2) was functioning marginally. The radar enclosure icing mitigation system ver. 1.5 may function most of the time to prevent ice buildup; however, the radar enclosure icing mitigation system ver. 1.5 is most likely to fail due to icing on the fascia when the DAS must function well to help the driver in the most critical whiteout conditions. The system could not prevent icing at speeds above 30 mph in heavy snow conditions. There were no major snowstorms at Kingvale after 04/14/2016.

The 4/14/2016 testing shows that the current radar enclosure icing mitigation system ver. 1.5 is a feasible solution in that the concept has been shown to work for light to medium snowfall, but that improvements must be made for the radar enclosure icing mitigation system ver. 1.5 to be able to handle heavy snowstorm conditions. The current radar enclosure icing mitigation system ver. 1.5 is a marginal stopgap measure, at best. The heat per unit area on the front face of the heated enclosure (ver. 1.2) must be increased, and the frontal area should be minimized. These major changes would require a complete redesign and manufacture of the radar enclosure icing mitigation system. This redesign, referred to as ver. 2.0, would include revisiting the heated enclosure, the heated wiper blade, and the wiper motor and controller. Retrofitting the heated enclosure (ver. 1.2) would not yield a satisfactory result.

AHMCT researchers also concluded that the current heated enclosure (ver. 1.2) design fundamentally failed. The current repaired heated enclosure ver. 1.2 is a stop-gap measure that will likely fail in about one year due to delamination of the interface of the Delrin fascia and the aluminum enclosure caused by failed epoxy adhesive. Therefore, the DAS will never work in the California snow environment if there is not a new, long-term, reliable, and robust solution to the radar enclosure icing issue. AHMCT researchers were actively pursuing work by MTS to develop a solution. Due to the small number of DASs sold by MTS, however, they are unlikely to develop an improved heated fascia for their California customer. A primary objective of this research program is to have the entire system manufactured and warrantied by a commercial company. Active, full-scale development of a custom radar enclosure icing mitigation solution was not carried out by AHMCT, as this was out of the scope of the project. Nevertheless, Figure 3.4 presents a conceptual 3D SolidWorks computer-aided design (CAD) model developed by AHMCT. The CAD model was used to facilitate discussion with potential commercial partners as well as to encourage them to participate in the solution development. Unfortunately, no commercial entity, including MTS or AutonomouStuff.com, has made any firm commitment to develop a radar enclosure icing mitigation solution.

Lessons Learned from Radar Enclosure Icing Mitigation System ver. 1.5 Design

- AHMCT performed a literature review of state-of-the-art deicing methods, including technologies used in aircraft radar dome deicing [15].
- The heated wiper system performed well.
- The heated enclosure ver. 1.2 heater power to the front fascia is inadequate. A higher-power heater is required.
- AHMCT tried to get a commercial solution
 - AutonomousStuff.com declined
 - MTS may be interested but has limited funding and personnel. Recent personnel changes in their DAS development group may preclude any effort by MTS.
- Delphi provides ESR fascia design recommendations in their internal documentation. This document is available upon request for the continued development of the radar enclosure icing mitigation solution.

Second-Generation Solution Concept

The radar enclosure icing mitigation system ver. 2.0 was designed in this research. This design features a heated wiper blade and marine grade wiper motor (the same motor used in radar enclosure icing mitigation system ver. 1.5) with a different heated front Delrin fascia design. The design uses higher heater power output for increased snow and ice melting. It also features reduced frontal area, to reduce heat power requirements. Finally, the ESR is not enclosed to avoid overheating by the Delrin front fascia heater. This system has not been tested. The design model is shown in Figure 3.4.

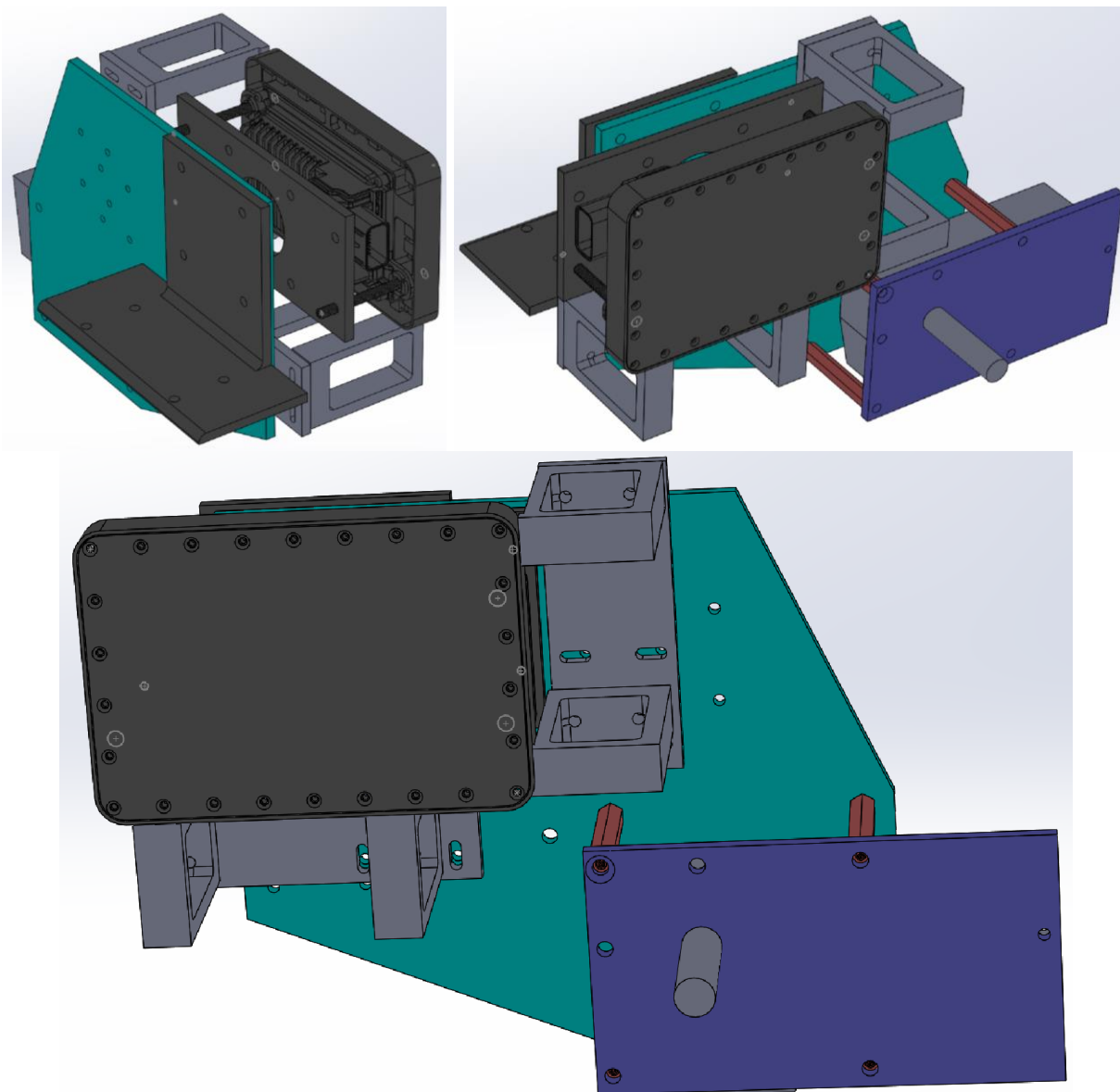

Figure 3.4: SolidWorks model of radar enclosure icing mitigation system ver. 2.0 with heated fascia

- The current heater power is limited by wire size and vehicle alternator power output. An alternator upgrade is needed.
- A higher-power heater may overheat the ESR if the ESR is housed inside a sealed enclosure. The radar enclosure icing mitigation system ver. 2.0 has an open heated front fascia design to keep the ESR from overheating.
- Teflon has better hydrophobic property than Delrin. Thus, Teflon should be used for the front fascia material in the radar enclosure icing mitigation system ver. 2.0 design.
- Reducing the frontal area of the fascia would reduce the heater power requirement.

Field Testing of the Snowplow Driver Assistance System

- Plastic or stainless fasteners should be used to eliminate the corrosion problem.
- A new heater temperature controller should be incorporated to enable a higher front fascia temperature.
- 3D printing of plastic parts would reduce the manufacturing cost.
- A new wiper controller is needed to control the wiper cycle frequency based on vehicle speed using GPS as a speed sensor. This would reduce wiper blade wear.
- Experiments should be performed for embedding heating wires in the front fascia.
- Extensive field testing is needed to ensure the reliability of the new design.

CHAPTER 4: GPS HUD-BASED DAS IMPLEMENTATION CONSIDERATIONS

This chapter highlights the important considerations required for any future implementation of the GPS HUD-based DAS in something approximating its current form. The implementation of the DAS in California for snowplows requires the radar enclosure icing issue to be resolved and fully tested.

Despite the DAS's current deficiencies of the radar enclosure icing and the enclosure delamination, a DAS can be implemented in dense fog areas (e.g., the San Francisco Bay Area bridges) where radar enclosure icing is not an issue. The Caltrans Emergency Maintenance Response manager, responsible for clearing accidents on all major bridges in the Bay Area, has expressed interest in testing and evaluating the DAS on their tow trucks in order to reduce response time in dense fog.

DAS Implementation on Snow Blowers

As noted in this chapter and elsewhere, radar enclosure icing and delamination issues currently preclude DAS implementation on snowplows. However, these icing and delamination issues were not encountered on the snow blower DAS. As such, implementation of the snow blower DAS is entirely feasible.

Due to the very limited snowfall in this and the prior research, the snow blower DAS was not extensively tested. The one condition that should be met prior to actual implementation of the snow blower DAS is such extended testing over at least one winter with sufficient snowfall to justify snow blower use.

Implementation of the snow blower DAS could yield important benefits. The DAS, including lateral positioning and forward obstacle detection, should enhance the safety of the snow blower operation. Of perhaps more significance, precise lateral positioning may yield maintenance and financial benefits, as the snow blower operator would be able to remove snow close to the guardrail without physically touching or impacting and thus potentially damaging the guardrail. Again, any conclusion that this benefit can actually be achieved is subject to additional field testing.

Prerequisite Conditions for DAS Implementation on Snowplows

1. Solving the radar enclosure icing problem:
 - a. The radar enclosure icing problem must be solved first before implementation on snowplows.
2. Solving the radar enclosure delamination issue:
 - a. The radar enclosure delamination problem must be solved before implementation on snowplows. The supply of spare replacement enclosures is very limited, and there is no source for additional enclosures once those are consumed. A modified enclosure needs to be designed. It should avoid the use of epoxy and should likely include a gasket.

- b. The new radar enclosure icing mitigation system ver. 2.0 design is based on a heated fascia. The ESR is not enclosed and no adhesive or gasket would be used. This design eliminates the delamination problem.
3. DAS installation improvement needed:
 - a. Currently, the DAS computer and the GNSS receiver are installed under the passenger seat, and the vibration motor on the driver seat is directly wired to the DAS electronics located under the passenger seat. When performing repairs on the snowplow engine and transmission, the driver and passenger seats must be removed in order to access the drivetrain components. Connectors should be added to allow breaking the electrical connection to the vibration motors so that the driver seat can be removed and reinstalled easily. In addition, bulkhead connectors should also be added to the DAS electronics installed under the passenger seat so that the electrical connections can be disconnected and connected easily during the removal and installation of the passenger seat. MTS has already incorporated most, if not all, of these features into their new generation DAS.
 4. Consider DAS limitations:

- a. GNSS availability at the deployment location

The DAS relies on GNSS for vehicle positioning. GNSS-challenged terrain areas, such as areas with tall tree vegetation, urban canyons, tunnels, and mountainous deep canyons, would degrade GNSS positioning performance. Therefore, the DAS would not work well on narrow two-lane highways with tall trees such as SR 20 and SR 299. SR 5, I-80, and SR 395 are good candidates for the DAS.

- b. GNSS Differential Services Options: single GNSS base station vs. GNSS network

The DAS requires GNSS differential services from either a single GNSS base station or a commercial GNSS differential network service, such as Trimble's VRS network or Leica's Spider Network. The use of commercial GNSS network services would eliminate the need for setting up a local base station and would enable the DAS to work in a wide area. The single GNSS base station differential service is only effective for about a 15-mile radius from the base station location. The California Surveying and Drafting Supply (CSDS) Real-Time Network (RTN) is a dynamic GNSS RTK network for California (see Figure 4.1 for coverage). Details are available at <http://www.csdsinc.com/gps-network-services/>. Based on the cost of the CSDS RTN (see Table 4.1), the return on investment (ROI) for a single GNSS base station over a commercial GNSS network is about 5.5 years per vehicle. For example, Bay Area tow truck deployment may use a commercial GNSS network to eliminate the need to set up a dedicated GNSS base station and to enable them to work on all major bridges. In the case of DAS deployment in two snowplows and one snow blower at Kingvale, the ROI for a single GNSS base station over a commercial GNSS network is about 1.8 years.

Policy Impact

A Local Request (LR) is required for the installation of the DAS onto a Caltrans vehicle. A LR was filed by DRISI before the installation of the DAS onto the snowplow for evaluation. This previous LR may be used as a template for future installations. In addition, depending on the power output of the alternator on the vehicle, the LR should include an alternator upgrade.

There were concerns regarding the use of the HUD combiner that covers the driver’s field of view when the DAS was first used on the snowplows. An exemption was made to allow the inclusion of the HUD combiner in the snowplow cab.

Mobile internet service is required for the DAS to receive differential GNSS data. The California Governor has put limits on adding mobile internet services. An exemption may be required for the mobile internet services.

Budgeting for the DAS

A sample DAS implementation budget is provided here. There are initial and recurring costs for keeping the DAS working and supporting users in the field. Table 4.2 itemizes the costs. The high-accuracy mapping data can be provided by mobile terrestrial laser scanning or by other means. Caltrans has two mobile terrestrial laser scanning systems in their inventory.

Table 4.2: DAS implementation budget items

Initial cost items	<ul style="list-style-type: none">• DAS equipment cost• DAS installation cost• GNSS base station setup or GNSS differential services setup cost• High-accuracy mapping cost• Initial operator training• Initial DOE mechanics training on system maintenance
Recurring cost items	<ul style="list-style-type: none">• Mobile internet data services• Differential GNSS data services if applicable• Continuing operator training• DAS maintenance

Stakeholder Roles and Responsibilities

To successfully implement the DAS, the stakeholders must be identified and cultivated before and during the implementation of the technology. Their roles and responsibilities must be clearly defined and communicated. The DAS implementation stakeholders and their possible roles and responsibilities are listed in Table 4.3. Additional personnel and financial resources would be required to support and complete these added tasks and responsibilities by each division or branch.

Table 4.3: DAS implementation stakeholders and their roles and responsibilities

Stakeholder	Role	Responsibility
Customer: Division of Maintenance	<ul style="list-style-type: none"> • Customer • Project management • DAS end users 	<ul style="list-style-type: none"> • LR filing • Procurement of the DAS • Procurement of wireless data services • Identify end users • Project management • Provide specifications of mapping detail • Continue training of operators • Filing exception for mobile internet data services
Division of Equipment (DOE)	<ul style="list-style-type: none"> • Review system and installation 	<ul style="list-style-type: none"> • Installation (optional at DOE’s discretion) • LR approval • System maintenance and diagnostics • Safety review on the use of combiner • Policy change approval if any
DRISI	<ul style="list-style-type: none"> • Support 	<ul style="list-style-type: none"> • Limited-term deployment support (optional)
District Surveys	<ul style="list-style-type: none"> • Support 	<ul style="list-style-type: none"> • Perform high-accuracy mapping according to mapping specifications (optional at Survey’s discretion) • GNSS base station setup and integration to GNSS network (possible to contract out services)
DAS provider	<ul style="list-style-type: none"> • System provider 	<ul style="list-style-type: none"> • DAS hardware • Mapping (optional at Survey’s discretion) • Map data integration • Installation (optional at DOE’s discretion) • Initial training: operators and system maintenance personnel • Warranty support
Caltrans IT	<ul style="list-style-type: none"> • Support 	<ul style="list-style-type: none"> • Define any IT documentation or exception that may be required • Exception for mobile internet data services

CHAPTER 5: CONCLUSIONS AND FUTURE RESEARCH

Research Findings Summary

- A significant amount of the work and time was spent on the testing and repair of a radar enclosure icing mitigation solution. A feasible radar enclosure icing mitigation system prototype ver. 1.5 (a heated enclosure and wiper with heated blade) was developed toward the end of the project. However, a radar enclosure icing mitigation system ver. 2.0 was designed to address the deficiencies found during testing. The radar enclosure icing issue must be solved first in order to proceed with any operational testing of the DAS for snowplows in whiteout conditions. As noted in Chapter 4 and below, the DAS is viable for other low-visibility situations.
- Due to the radar enclosure icing problem, field operational testing did not start until near the end of the project.
- Due to differences in the operating environment (vehicle speed), the radar enclosure icing issue did not occur on the snow blower. A final conclusion regarding this issue for the snow blower would require additional field testing.
- All operators liked and provided positive comments regarding the vibration seat feature.

Future Work and Recommendations

- Currently, only a 3G modem was used for the communication link between the GNSS base station and the GNSS receivers on the DAS snowplows and snow blower. A 4G Long-Term Evolution (LTE) modem will decrease latency, increase bandwidth, and may increase coverage. The Verizon LTE 750 MHz RF band theoretically will provide longer range and better propagation in mountainous areas due to its lower radio frequency compare to 3G frequencies of 850 MHz and 1900 MHz. The modem should be upgraded and tested for performance.
- The snowplow alternator should be upgraded from a 74-Amp output to a higher-output alternator such as a 125-Amp or higher output alternator in future DAS installations. This upgrade should be included in the LR.
- The current roadway image overlay does not utilize the entire combiner. A smaller combiner would be easier to move into position. It would also obscure a smaller portion of the driver's field of vision.
- An LCD display with higher contrast, darker black, and high-brightness screen would improve the roadway image overlay. However, this is limited by available COTS LCDs.
- The radar enclosure icing mitigation solution worked well in medium snowfall. It is inadequate to handle snowfall with the vehicle driving into a headwind. Generally, there is higher headwind traveling westbound on I-80 between Donner Lake Interchange (DLI) and

Kingvale, where whiteout conditions appear first in the area during a snowstorm. However, additional development and testing is needed to modify the enclosure's heat output and to evaluate its reliability.

- The radar enclosure delamination problem must be solved before implementation on snowplows. It is not clear whether this is also a problem with snow blowers, but it likely is. There is a very limited supply of spare replacement enclosures, and no source for additional enclosures once those are consumed. A modified enclosure needs to be designed. It should avoid the use of epoxy, use mechanical fasteners, and likely include a gasket.
- The GNSS receiver worked well in providing an accurate positional solution throughout the project site. However, there are a few small gaps where the RTK GNSS solution is not available. Integration with an inertial measurement unit would reduce these gaps and improve system availability. On the other hand, this would increase the system cost and complexity.
- Due to constant snowplow operator changes, ongoing training is needed and should be planned for in deployment. Caltrans will have to determine an effective means to train its personnel based on the known transient nature of its snowplow operators.
- Due to changes in the roadway delineation, there were some small discrepancies between the digital maps and the roadway. The digital maps should be updated. Maintenance should implement plans to identify roadway feature changes in the summer to allow time for updated mapping generation for winter use.
- Better system integration would reduce installation time, system size, and exposed wiring.
- A maintenance and operational checklist and a toolkit are needed.
- The heated wiper blade used on the radar may require replacement every two years.
- Connectors should be added between both passenger and driver seats to the vehicle cab so that the system or seat can be easily taken out to support vehicle repair.
- The combiners require careful cleaning at the beginning of every snow season. Dust and fingerprints hinder the clarity of the HUD image. The combiners should be removed and stored for safekeeping during the off-season.

Go/No Go Decisions

The DAS will never work for snowplows if there is not a long-term, reliable, and robust solution to the radar enclosure icing issue. The current radar enclosure icing mitigation system ver. 1.5 is inadequate during heavy snowstorms, but a feasible solution is provided by the radar enclosure icing mitigation system ver. 2.0 discussed in Chapter 3. Additional resources for the development and testing of the anti-icing solution are required.

Caltrans stakeholders should decide whether to:

1. Provide addition resources for the development and testing of the radar enclosure anti-icing solution,
- or
2. Discontinue the deployment of the DAS for snowplows.

As noted, DAS implementation for the snow blower does appear feasible. This follows since the radar enclosure icing and delamination issues were not encountered on the snow blower DAS. The one condition that should be met prior to actual implementation of the snow blower DAS is such extended testing over at least one winter with sufficient snowfall to justify snow blower use. The key benefit of the snow blower DAS would be precise lateral positioning which could yield maintenance and financial benefits, as the snow blower operator would be able to remove snow close to the guardrail without physically touching or impacting and thus potentially damaging the guardrail. Again, any conclusion that this benefit can actually be achieved is subject to additional field testing.

As discussed in Chapter 4, the DAS will work in dense fog conditions often encountered in the San Francisco Bay Area. The Bay Area Emergency Response manager has expressed interest in evaluating this technology for tow trucks responsible for clearing accidents on Bay Area bridges. The DAS may reduce the response time to vehicle collision sites in dense fog.

REFERENCES

1. B. Ravani, T. Lasky, B. Newstrom, C. Shankwitz, and K. Yen, "Evaluation of the University of Minnesota GPS Snowplow Driver Assistance System " AHMCT Research Center Rept. # UCD-ARR-15-08-30-01, 2015.
2. L. Alexander, P.-M. Cheng, M. Donath, A. Gorjestani, B. Newstrom, C. Shankwitz, and W. Trach Jr, "DGPS-Based Lane Assist System for Transit Buses," in *Proceedings of the International IEEE Conference on Intelligent Transportation Systems*, pp. 755-760, 2004.
3. S. Bajikar, A. Gorjestani, P. Simpkins, and M. Donath, "Evaluation of in-Vehicle GPS-Based Lane Position Sensing for Preventing Road Departure," in *IEEE Conference on Intelligent Transportation System*, pp. 397-402, 1997.
4. M. Donath, B. Newstrom, C.R. Shankwitz, A. Gorjestani, H. Lim, and L. Alexander, "Real Time High Accuracy Geospatial Database for Onboard Intelligent Vehicle Applications," US Patent 7072764, 2006.
5. M. Donath, C. Shankwitz, L. Alexander, A. Gorjestani, P. Cheng, and B. Newstrom, "Bus Rapid Transit Lane Assist Technology Systems," Dept. of Mechanical Engineering, University of Minnesota, 2003.
6. A. Gorjestani, L. Alexander, B. Newstrom, P.-M. Cheng, M. Sergi, C. Shankwitz, and M. Donath, "Driver Assistive Systems for Snowplows," Dept. of Mechanical Engineering, University of Minnesota Rept. # MN/RC – 2003-13, 2003.
7. A. Gorjestani, M. Donath, and L. Alexander, "Radar Based Longitudinal Virtual Bumper Collision Avoidance System Implemented on a Truck," Dept. of Mechanical Engineering, University of Minnesota Rept. # MN/RIC - 2000-07, 1999.
8. A. Gorjestani, B. Newstrom, C. Shankwitz, and M. Donath, "Advanced Range Sensor Processing Using DGPS and a Geospatial Database," in *Proceedings of Intelligent Transportation Systems Conference*, pp. 722-727, 2001.
9. A. Gorjestani, T. Pham, S. Bajikar, and M. Donath, "Evaluation of Radar for Snowplows: Initial Results," Dept. of Mechanical Engineering, University of Minnesota Rept. # MN/RIC - 1999-09, 1998.
10. H.-M. Lim, B. Newstrom, C. Shankwitz, and M. Donath, "A Heads up Display Based on a DGPS and Real Time Accessible Geo-Spatial Database for Low Visibility Driving," in *Proceedings of the 12th International Meeting of the Satellite Division of the Institute of Navigation*, 1991.
11. H.-M. Lim, B. Newstrom, C. Shankwitz, and M. Donath, "A Conformal Augmented Head up Display for Driving under Low Visibility Conditions," in *Proceedings of the 5th International Symposium on Advanced Vehicle Control*, Ann Arbor, MI, 2000.
12. K.S. Yen, H.-S. Tan, A. Steinfeld, C. Thorne, B. Bougler, E. Cuelho, P. Kretz, D. Empey, R. Kappesser, H. Ghaida, M. Jenkinson, S. Owen, W.-B. Zhang, T.A. Lasky, and B. Ravani, "Advanced Snowplow Development and Demonstration: Phase I: Driver Assistance," AHMCT Research Center Rept. # UCD-ARR-99-06-30-03, 1999.
13. K.S. Yen, H.-S. Tan, A. Steinfeld, C. Thorne, S. Donecker, B. Bougler, P. Kretz, D. Empey, R. Kappesser, H. Ghaida, M. Jenkinson, S. Owen, W.-B. Zhang, T.A. Lasky, and B. Ravani, "Development of an Advanced Snowplow Driver Assistance System (ASP-II)," AHMCT Research Center Rept. # UCD-ARR-00-06-30-02, 2000.
14. K.S. Yen, H.-S. Tan, A.-J. van Zadelhoff, J. Lins, B. Bougler, K. Hawley, A. Nazari, A. Steinfeld, P. Kretz, V. Reveles, R. Battersby, M. Jenkinson, S. Owen, W.-B. Zhang, T.A.

- Lasky, and B. Ravani, "A Rural Field Test of the RoadView System," AHMCT Research Center Rept. # UCD-ARR-02-06-30-01, 2002.
15. V. Volman, Y. Zhu, A.-R.O. Raji, B. Genorio, W. Lu, C. Xiang, C. Kittrell, and J.M. Tour, "Radio-Frequency-Transparent, Electrically Conductive Graphene Nanoribbon Thin Films as Deicing Heating Layers," *Applied Materials and Interfaces*, 6(1): pp. 298-304, 2014.