

|  |                                  |  |
|--|----------------------------------|--|
| 1. REPORT NUMBER<br><br>CA16-2529  | 2. GOVERNMENT ASSOCIATION NUMBER | 3. RECIPIENT'S CATALOG NUMBER  |
| 4. TITLE AND SUBTITLE<br>Advanced Traffic Signal Control Algorithms Phase II   | 5. REPORT DATE<br>12/15/2015     |  |
| 7. AUTHOR<br><br>Dr. Wei-Bin Zhang and Dr. Matthew Barth   |                                  | 6. PERFORMING ORGANIZATION CODE  |
| 9. PERFORMING ORGANIZATION NAME AND ADDRESS<br>California PATH<br>1357 S.46th Street, Building. 452<br>Richmond, CA 94804-4648   |                                  | 8. PERFORMING ORGANIZATION REPORT NO.  |
| 12. SPONSORING AGENCY AND ADDRESS<br>California Department of Transportation<br>Division of Research, Innovation, and System Information<br>1227 O Street<br>Sacramento, CA 95814  |                                  | 10. WORK UNIT NUMBER   |
| 15. SUPPLEMENTARY NOTES<br>This work was performed as part of the California PATH program of the University of California Berkeley and UC Riverside, in cooperation with the State of California Business, Transportation and Housing Agency, Department of Transportation, and the United States Department of Transportation, Federal Highway Administration.  |                                  | 11. CONTRACT OR GRANT NUMBER<br><br>24-13-13159  |
| 16. ABSTRACT<br><br>The goal of the project was to design and implement an in-vehicle system that calculates and provide speed advice to the driver of the vehicle, using Signal Phase and Timing (SPaT) and Geometric Information Description (GID) information of the signalized intersection, allowing the driver to adapt the vehicle's speed to pass through the upcoming actuated traffic signal(s) on green or to decelerate to a stop at a red signal in the most environmentally efficient manner.<br>The testing of the system revealed that the fuel saving performance varies from 0 to 22 percent for different driving scenarios. The three scenarios of "speed up to pass (during green)", "have to stop (from green to red)" and "maintain speed to pass (from red to green)" can potentially make improvement by following in-vehicle speed advisory recommendations. Having considered the occurrence chance of every scenario, the statistical results show that the real achieved benefit for the tests ranges between 3% to 4%. |                                  | 13. TYPE OF REPORT AND PERIOD COVERED<br>Final Report                                    |
| 17. KEY WORDS<br>Actuated Traffic signals, Green House Gas Reduction, In-Vehicle Speed Advisory, Adaptive Control, Connected Vehicles, Mathematical Models, and Dedicated Short Range Communication (DSRC)   |                                  | 14. SPONSORING AGENCY CODE   |
| 19. SECURITY CLASSIFICATION (of this report)<br><br>Unclassified   | 20. NUMBER OF PAGES<br><br>102   | 18. DISTRIBUTION STATEMENT<br>This document can be distributed without any restrictions. |
|  |                                  | 21. COST OF REPORT CHARGED   |

## **DISCLAIMER STATEMENT**

This document is disseminated in the interest of information exchange. The contents of this report reflect the views of the authors who are responsible for the facts and accuracy of the data presented herein. The contents do not necessarily reflect the official views or policies of the State of California or the Federal Highway Administration. This publication does not constitute a standard, specification or regulation. This report does not constitute an endorsement by the California Department of Transportation (Caltrans) of any product described herein.

For individuals with sensory disabilities, this document is available in braille, large print, audiocassette, or compact disk. To obtain a copy of this document in one of these alternate formats, please contact: the California Department of Transportation, Division of Research Innovation, and Systems Information, MS-83, P.O. Box 942873, Sacramento, CA 94273-0001.

# **Advanced Traffic Signalization: Extending the Eco-Approach and Departure Application Research to Actuated Traffic Signals**

*FHWA Exploratory Advanced Research (EAR) Program*

## **Final Report**

**California PATH, University of California, Berkeley  
CE-CERT, University of California, Riverside  
California Department of Transportation  
USDOT Federal Highway Administration**

December 2015



## **Authors and Contributors**

### **California Partners for Advanced Technologies (PATH)**

#### **University of California at Berkeley**

Huadong Meng

Kun Zhou

Qinzhou Mao<sup>1</sup>

Jiali Bao<sup>2</sup>

Wei-Bin Zhang

### **Center for Environmental Research & Technology (CE-CERT)**

#### **University of California at Riverside**

Peng Hao

Guoyuan Wu

Matthew Barth

### **California Department of Transportation**

Asfand Y Siddiqui

Peter Gurprit S Hansra

---

<sup>1</sup> Visiting Assistant Research Engineer, Currently, Associate Professor of Wuhan University

<sup>2</sup> Visiting Student at PATH, Currently PhD Student with University of Tokyo

# Table of Content

|  |           |
|--|-----------|
| <i>Center for Environmental Research &amp; Technology (CE-CERT)</i> .....        | <i>i</i>  |
| <b>1 Introduction</b> .....  | <b>1</b>  |
| 1.1 Project Summary .....  | 2         |
| 1.1.1 <i>Project Scope</i> .....   | 2         |
| 1.1.2 <i>Research Questions</i> .....  | 4         |
| 1.2 Principles of Eco-Approach and Departure.....                                | 4         |
| 1.2.1 <i>EAD Scenarios</i> .....   | 4         |
| 1.2.2 <i>Actuated Signals and Their Remaining Time Estimations</i> .....         | 7         |
| 1.2.3 <i>Driver Vehicle Interface Design</i> .....                               | 9         |
| <b>2 Framework of Eco-Approach and Departure System</b> .....                    | <b>15</b> |
| 2.1 Overview of DSRC Supported Traffic Signal System .....                       | 15        |
| 2.1.1 <i>DSRC Applications and Components</i> .....                              | 15        |
| 2.1.2 <i>Diagram of EAD Application</i> .....                                    | 16        |
| 2.2 Overview of Infrastructure.....  | 17        |
| 2.2.1 <i>Field Test Corridor</i> .....   | 17        |
| 2.2.2 <i>Setup of Intersection Facilities</i> .....                              | 19        |
| 2.2.3 <i>Geometric Intersection Description</i> .....                            | 20        |
| 2.2.4 <i>SPaT and MAP Messages</i> .....   | 23        |
| 2.3 Overview of Test Vehicles .....  | 25        |
| 2.3.1 <i>PATH Test Vehicle</i> .....   | 25        |
| 2.3.2 <i>UC Riverside Test Vehicle</i> .....                                     | 28        |
| <b>3 Trajectory Planning Algorithms</b> .....                                    | <b>31</b> |
| 3.1 Approach I (UC Berkeley) .....   | 31        |
| 3.1.1 <i>System Offline Input: Fuel Consumption Modeling</i> .....               | 32        |
| 3.1.2 <i>System Online Input: Vehicle Location and Signal Timing</i> .....       | 34        |
| 3.1.3 <i>Speed Trajectory Planning Algorithm</i> .....                           | 35        |
| 3.1.4 <i>Incorporating driver behavior model</i> .....                           | 37        |
| 3.2 Approach II (UC Riverside) .....   | 41        |
| 3.2.1 <i>System Architecture</i> .....   | 41        |
| 3.2.2 <i>Approaching During Green or Yellow Phase</i> .....                      | 44        |
| 3.2.3 <i>Approaching During Red Phase</i> .....                                  | 45        |
| 3.2.4 <i>Safe Headway Detection Using Radar</i> .....                            | 46        |
| <b>4 DVI Review and Designs</b> .....  | <b>48</b> |
| 4.1 Analysis of Candidate DVI items.....   | 48        |
| 4.2 Discussion on DVI Issues.....  | 50        |
| 4.2.1 <i>Traffic Signal State and Countdown</i> .....                            | 50        |
| 4.2.2 <i>Stopping Unavoidable Scenario</i> .....                                 | 51        |
| 4.2.3 <i>Maintaining a Target Speed to Clear the Intersection Scenario</i> ..... | 51        |
| 4.2.4 <i>Decelerate to a Lower Speed to Avoid a Stop Scenario</i> .....          | 52        |
| 4.3 DVI Design I (UC Riverside) .....  | 53        |
| 4.4 DVI Design II: Virtual Preceding Car (UC Berkeley).....                      | 55        |
| 4.5 DVI Design III: Target Speed Information (UC Berkeley) .....                 | 57        |
| 4.5.1 <i>Eco-Advice: Accelerate to a Target Speed</i> .....                      | 59        |
| 4.5.2 <i>Eco-Advice: Prepare to Stop and Begin Coasting</i> .....                | 60        |

|          |   |           |
|----------|---|-----------|
| 4.5.3    | <i>Slow to a Target Speed</i>                               | 61        |
| <b>5</b> | <b>Testing Results</b>                                      | <b>63</b> |
| 5.1      | Field Testing Conducted By PATH                             | 63        |
| 5.1.1    | <i>Fuel Saving Metrics</i>                                  | 63        |
| 5.1.2    | <i>Example Trips of Different Scenarios</i>                 | 64        |
| 5.1.3    | <i>Statistical Results and Conclusions</i>                  | 68        |
| 5.1.4    | <i>Preliminary Results of Human Factor Issues</i>           | 71        |
| 5.2      | Field Testing Conducted by CE-CERT                          | 73        |
| 5.2.1    | <i>Numerical Validation in Simulation</i>                   | 73        |
| 5.2.2    | <i>Test on Different Scenarios in Riverside, California</i> | 76        |
| 5.2.3    | <i>Field Test in El Camino Real</i>                         | 82        |
| <b>6</b> | <b>Summary</b>  | <b>87</b> |
| 6.1      | Project Summary   | 87        |
| 6.2      | Further Research Topics and Recommendations                 | 88        |
|          | <b>References</b>   | <b>90</b> |

## List of Figures

|  |    |
|--|----|
| Fig. 1.1 Illustration of different vehicle trajectories approaching an intersection.....         | 5  |
| Fig. 1.2 Scenario partitions with respect to the initial speed and time to signal change .....   | 7  |
| Fig. 1.3 Green Interval of an Actuated Phase (Source: [7]) .....                                 | 8  |
| Fig. 1.4 Simple Qualitative Eco-Driving Feedback.....  | 12 |
| Fig. 1.5 eCoMove Intersection (Left) and Curve (Right) Eco-Driving Assistant .....               | 13 |
| Fig. 1.6 Intermittent vs. Continuous Eco-Driving Display.....                                    | 14 |
| Fig. 2.1 DSRC components at a signalized intersection .....                                      | 16 |
| Fig. 2.2 Information flow of EAD application .....   | 17 |
| Fig. 2.3 Test bed at El Camino Real.....   | 18 |
| Fig. 2.4 Intersection facilities.....  | 19 |
| Fig. 2.5 Plotting of intersection GID map.....   | 21 |
| Fig. 2.6 MAP Data Objects.....   | 24 |
| Fig. 2.7 Diagram of test vehicle setup .....   | 26 |
| Fig. 2.8 Algorithm components of on-board system.....  | 28 |
| Fig. 2.9 Test vehicle: a 2008 Nissan Altima .....  | 29 |
| Fig. 2.10 In-vehicle components .....  | 29 |
| Fig. 3.1 Architecture of algorithm .....   | 32 |
| Fig. 3.2 Empirical fuel flow rate model.....   | 33 |
| Fig. 3.3 Matching of the empirical model and real fuel flow rates .....                          | 33 |
| Fig. 3.4 Processing flow of <i>LocationAware</i> program .....                                   | 34 |
| Fig. 3.5 Processing flow of <i>SignalAware</i> program.....                                      | 34 |
| Fig. 3.6 Diagram of speed trajectory planning algorithm .....                                    | 36 |
| Fig. 3.7 Closed-loop speed advisory implementation.....  | 37 |
| Fig. 3.8 An example trajectory of using the closed-loop base model .....                         | 39 |
| Fig. 3.9 The block diagram of the CEAHV and CEAHV-C model.....                                   | 41 |
| Fig. 3.10 Architecture and Components of the EAD VPT algorithm.....                              | 43 |
| Fig. 3.11 Flowchart of eco-approach during green or yellow phase.....                            | 44 |
| Fig. 3.12 Flow chart of eco-approach during red phase .....                                      | 46 |
| Fig. 3.13 State machine for dealing with preceding vehicles .....                                | 47 |
| Fig. 4.1 Artificial dashboard for field testing (Design of UC Riverside).....                    | 54 |
| Fig. 4.2 DVI description of the Virtual Preceding Car (VPC) design.....                          | 55 |
| Fig. 4.3 DVI Messages for different scenarios (VPC design) .....                                 | 56 |
| Fig. 4.4 DVI design dealing with a preceding vehicle (VPC design) .....                          | 57 |
| Fig. 4.5 Nissan Altima (2008) dashboard layout.....  | 58 |
| Fig. 4.6 Basic display layout (TSI design).....  | 58 |
| Fig. 4.7 Recommendation instructing to accelerate (TSI design).....                              | 60 |
| Fig. 4.8 Recommendation instructing to prepare to stop (TSI design).....                         | 61 |
| Fig. 4.9 Recommendation instructing to coast to a slower speed (TSI design) .....                | 61 |
| Fig. 4.10 Recommendation confirming the signal will turn green before arrival (TSI design).....  | 62 |
| Fig. 5.1 Sample trip of Scenario I1 (fuel consumption unit: gram) .....                          | 65 |
| Fig. 5.2 Sample trips of Scenario I2 .....   | 65 |
| Fig. 5.3 Sample trip of Scenario I3 .....  | 66 |
| Fig. 5.4 Sample trips of Scenario I5 .....   | 66 |
| Fig. 5.5 Sample trip of Scenario I6 .....  | 67 |
| Fig. 5.6 Sample trips at successive intersections (El Camino Real) .....                         | 67 |
| Fig. 5.7 Relative fuel consumptions with respect to scenario indicator .....                     | 68 |
| Fig. 5.8 Drivers' distraction durations and frequencies of the tests for three DVI designs ..... | 72 |
| Fig. 5.9 Simulated vehicle trajectories of informed and uninformed driving.....                  | 73 |

|  |           |
|--|-----------|
| <b>Fig. 5.10 Emissions of CO<sub>2</sub> per mile vs. arrival time .....</b>                               | <b>75</b> |
| <b>Fig. 5.11 Field Test at Palmyrita Ave, Riverside.....</b>   | <b>77</b> |
| <b>Fig. 5.12 Vehicle trajectories for traffic scenario 1 .....</b>   | <b>80</b> |
| <b>Fig. 5.13 Vehicle trajectories for traffic scenario 4 .....</b>   | <b>82</b> |
| <b>Fig. 5.14 Two scenarios for EAD implementation in El Camino Real field test.....</b>                    | <b>84</b> |
| <b>Fig. 5.15 Travel times of southbound (upper) and northbound trips (lower) .....</b>                     | <b>85</b> |
| <b>Fig. 5.16 Second-by-second trajectories for the field test .....</b>                                    | <b>86</b> |
| <b>Fig. 5.17 Average CO<sub>2</sub> emission of southbound (upper) and north bound trips (lower) .....</b> | <b>86</b> |



## List of Tables

|  |    |
|--|----|
| Table 1.1 Determination of Instantaneous Scenarios.....                                  | 6  |
| Table 2.1 Typical applications of DSRC .....   | 15 |
| Table 2.2 List of intersection along California test bed (from north to south).....      | 18 |
| Table 2.3 The structure of nmap file header .....  | 21 |
| Table 2.4 The structure of each approach in an nmap file.....                            | 22 |
| Table 2.5 In-memory database (Datahub) variable description .....                        | 27 |
| Table 3.1 Measures of fuel consumption model .....                                       | 32 |
| Table 4.1 Analysis of candidate DVI elements .....                                       | 49 |
| Table 4.2 Recommendation messages and their corresponding scenarios (VPC design).....    | 55 |
| Table 5.1 Scenario transition pattern and their fuel consumption performances .....      | 69 |
| Table 5.2 Fuel cons. improvements for different scenarios and different DVI designs..... | 70 |
| Table 5.3 Comparisons between driver's normal behavior and EAD recommendation .....      | 70 |
| Table 5.4 Occurrence probabilities of all the scenarios.....                             | 71 |
| Table 5.5 Emission Performance of the proposed EAD algorithm .....                       | 75 |
| Table 5.6 Energy and emission saving in percentage .....                                 | 76 |
| Table 5.7 Four traffic scenarios for EAD test.....                                       | 78 |
| Table 5.8 Energy saving percentage for traffic scenario 1 .....                          | 80 |
| Table 5.9 Energy saving percentage for traffic scenario 2 .....                          | 81 |
| Table 5.10 Energy saving percentage for traffic scenario 3.....                          | 81 |
| Table 5.11 Energy saving percentage for traffic scenario 4.....                          | 82 |

# 1 Introduction

In 2008, the Environmental Protection Agency (EPA) required that all new vehicles comply with the SAE OBD II standards (Title 40, Code of Federal Regulations, Part 86.1806-05), effectively allowing third-party access to fuel economy and instantaneous fuel consumption data on all new vehicles. While many automotive OEM's already offered fuel economy information displays to drivers, the 2008 EPA requirement also spawned an increasingly rich market for aftermarket eco-driving systems and smartphone-based eco-driving systems, utilizing the data available that is now available through the vehicle's OBD II port. The open OBD II standard, the skyrocketing cost of fuel over the first decade of the new millennium, the introduction of hybrid-electric and electric vehicles to the market, and the global focus on reducing greenhouse gas emissions have all contributed to the recent interest in and growing body of research related to the development of eco-driving assistants.

In terms of all energy and environmentally beneficial ITS applications, those involving traffic signals are promising in the near term, primarily because many of the supporting technologies exist today and can be readily utilized, resulting in potentially significant environmental benefits. The concept of "Eco-signal" operation applications can be generalized to include the use of connected vehicle technologies to decrease fuel consumption as well as greenhouse gases (GHGs) and criteria air pollutant emissions on roadways with traffic signals by reducing the number of stops and idling, avoiding unnecessary acceleration and deceleration events, and improving traffic flow at signalized intersections [1][2][3][4][5].

At the foundation of the eco-signal operations concept are wireless data communications between enabled vehicles and roadside infrastructure. A primary example of this is the "Eco-Approach & Departure at Signalized Intersection" (EAD) application. In this application, a traffic signal broadcasts its Signal Phase and Timing (SPaT) and Geometric Intersection Description (GID) information (also denote a map) to approaching vehicles at the intersection where it is located. In-vehicle systems then use this information along with the vehicle's position and speed, to perform calculations and provide speed advice to the driver, allowing the driver to adjust the vehicle's speed to pass through the upcoming signal on green or to decelerate to a stop in the most eco-friendly manner. In essence, this EAD technology encourages "green" driving while approaching, passing through, and departing signalized intersections.

Previous simulation-based research has proposed speed planning algorithms for the eco-approach technology on signalized corridors, and demonstrated approximately 12% - 18% fuel savings and emission reductions by means of traffic simulation with a single vehicle [1]. Moreover, sensitivity analyses of the traffic simulation were carried out under different penetration rates and congestion levels, showing a significant indirect network-

wide effect, meaning that not only do the connected vehicles benefit, but the non-connected vehicles also gain some fuel savings and emission reductions by following the connected vehicles [2].

In terms of field testing, initial eco-approach experimentation was carried out by BMW, UC Riverside, and UC Berkeley as part of the existing FHWA EAR Advanced Signalization project. This research was carried out at the PATH Richmond Field Station in early 2012 where a single vehicle (instrumented BMW) drove through a fixed timed signal at various times in the cycle. It was shown that approximately 13.6% fuel savings were achieved [6]. Further fixed-time signalization field studies were carried out as part of the AERIS program at UC Riverside and the Turner Fairbanks Highway Research Center later in the summer of 2012. This testing was more comprehensive in terms of the experimentation setup and scenario analysis; it was found that significant fuel savings (and carbon dioxide emission reductions) were achieved on average, typically in the range from 10% to 25%. The results depend on a number of factors, including the vehicle entry and exit speeds to the intersection, the vehicle type, driver variability, and terrain.

It is important to note that these field studies to date consisted of a single vehicle traveling without traffic through an intersection with fixed-time signalization. However, the majority of the intersections across the United States use actuated or semi-actuated signalization.

For the fixed-time signalization experiments, the SPaT messages contain dynamic information about the traffic signal, such as the current and future phase timings, as well as the current status of the signal. The SPaT message for actuated coordinated traffic signals contains the same information as the message for fixed-time traffic signals, but is extended by some additional fields. The key difference is that for actuated traffic signals, the earliest and latest points of time for state change are usually different to address the uncertainties in phase durations that are influenced by pedestrian/vehicle calls and vehicle actuations from cross traffic.

Based on the consideration of generalizing the use of intersection eco-driving technology, the FHWA EAR Advanced Signalization project has been extended to the situation of actuated signals. In this project, the studies are conducted to get a deep understanding of the mechanism of EAD in real traffic, and also to obtain the achievable fuel saving performance in real traffic rather than the previous experimental results.

## **1.1 Project Summary**

### **1.1.1 Project Scope**

Vehicle EAD algorithms use Signal Phase and Timing (SPaT) and Geometric Intersection Description (GID) information to determine and provide driver recommendations to encourage eco-friendly driving as the vehicle approaches a signalized intersection, travels through the intersection and along the departure leg. Upon receiving SPaT and GID information, in-vehicle systems calculate and provide speed advice to the driver of the vehicle, allowing the driver to adapt the vehicle's speed to pass through the upcoming signal(s) on green or to decelerate to a stop at a red signal in the most environmentally efficient manner.

During the past ten years, this project team has been working on Eco-Approach issue through the following projects:

1. **Development of the concept of Eco-approach:** Under a project sponsored by Audi, the research team at UC Berkeley and UC Riverside developed the original concept of Eco-approach, intending to influence driver behavior through advance information about traffic signal status to alert drivers to release their throttle earlier and decelerate gently. Under this study, an advisory system is modeled to estimate the benefits of fuel savings and reduction of emissions and pollutants.
2. *Development of speed-advisory algorithms under different traffic conditions:* Initial testing carried out by PATH, CE-CERT and BMW as part of the existing FHWA EAR Advanced Signalization Project revealed that the speed advisory algorithms that only use signal status have limitations. For example, when the subject vehicle is traveling in the traffic stream, the advice speed is often different from the speed of the preceding vehicle therefore it is difficult for the driver to adapt. UCB PATH and UCR have worked independently to modify the speed advisory algorithms to deal with multiple vehicle interactions. These enhanced algorithms have been tested at the RFS test intersection and then in the test bed under real traffic conditions, in part 3.
3. *Comprehensive testing with a controlled test intersection:* Similar to the initial testing at UC Berkeley's Richmond Field Station, followed by comprehensive testing on a controlled test intersection at UC Riverside, then later at Turner Fairbanks Highway Research Center (TFHRC), specific scenarios have been set up that evaluate the Eco-Approach algorithm under different variables, including signal cycle time, entry and exit vehicle speed, and level of cross-traffic actuation. This research has been carried out at UC Riverside using the portable traffic signal system developed under the RITA-AERIS program and UC Riverside's test vehicle.
4. *Real-world driving scenario testing:* Using the enhanced algorithms developed in parts 1 and 2, we have carried out field testing at the instrumented arterial corridor on El Camino Real in Palo Alto, California, to obtain the realizable fuel saving performance under real-world traffic conditions.

The previous research results revealed that the Eco-Approach and Departure algorithms needed to be extended and improved to include the consideration of: 1) the interactions with a preceding vehicle such that driver recommendations are consistent with real-world driving conditions; 2) the uncertainties in estimation of green and red phase durations for actuated signals; and 3) the methods of providing speed recommendations, which can be easily received and followed by a driver. This research funded under the FHWA EAR Advanced Traffic Signalization project is intended to develop and quantify potential benefits of Eco-Approach and Departure algorithms with actuated traffic signals under real-world conditions with vehicle interactions and phase duration uncertainties.

### **1.1.2 Research Questions**

Although this project has made its main effort on the establishing of the test system and conducting evaluation experiments, the project team expects to answer several scientific questions that were abstracted from the technology essentials.

- How to generate “reliable” advisory information based upon uncertainties of signal phase change in actuated signals?

Previous studies have presented comprehensive results under the situations of fixed timing signals. Actuated signals have sensors in the road that detect the presence of vehicles typically in all directions and change their signal timing based on those sensor outputs. The uncertainties of timing brought by actuated signals will make the signal phase at the moment the vehicle is right behind stop line difficult to predict, which will jeopardize the reliability of the algorithm and corresponding recommendations. Using minimum green and maximum red will be the most convenient solution for the safety concern but definitely would not be the most beneficial for fuel consumption. Then the question is, is there a method to achieve balance between safety and economy when using inaccurate or fuzzy values for signal countdown?

- What are the effective means to influence driving behavior with minimum distraction?

In several previous studies on human factors of an eco-driving DVI system, the driver’s distraction was mentioned and compared as optional metrics for scheme evaluation. For the situation of intersections, the driver’s distraction is more critical because they must pay more attention to the traffic environment than driving freely. Then, the DVI elements which are more unambiguous (easy to understand) and more straightforward (easy to follow) will be considered as candidate interfaces and be fully investigated.

- To what extent the proposed EAD application can facilitate fuel saving and emission reduction in a real-world traffic environment?

The previous studies have given a few results of fuel saving performance, however in ideal environments including fixed-time signals, repeatable signal timing with respect to initial vehicle status, and no parallel traffic. Once the condition of real traffic is taken into consideration and tested, would the realizable performance still be significant enough?

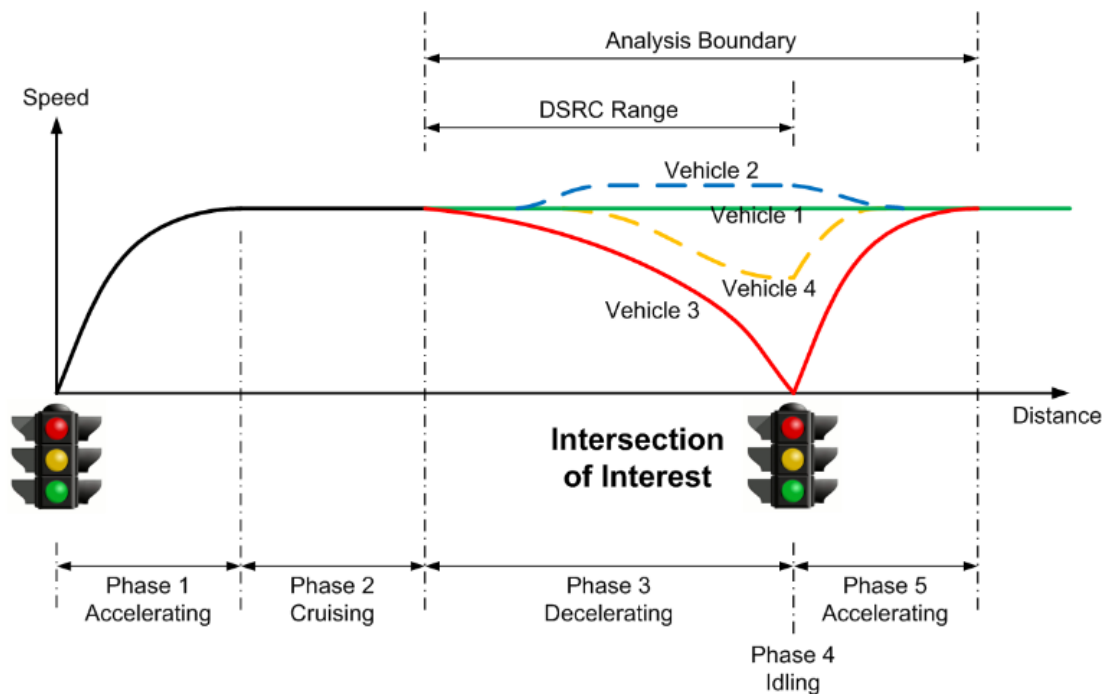
## **1.2 Principles of Eco-Approach and Departure**

### **1.2.1 EAD Scenarios**

The scenarios of an individual vehicle (without interaction with other traffic) traveling through a single signalized intersection in one direction (i.e., with no lane changes) and flat (i.e., assuming the road grade is trivial) roadway are illustrated in Fig. 1.1. In this figure, velocity trajectories of four different vehicles confronted with the traffic light at different signal phases and timings are shown by the green, blue, red, and yellow lines. It is also noted that all these trajectories have the same initial velocity  $v_i(t)$ , and same starting

distance  $d(t)$ . More specifically, the scenarios can be divided into the following four trajectory cases that are denoted as **Trajectory Scenarios**:

- Trajectory Scenario 1 (T1): vehicle cruises through the intersection at a constant speed (green line);
- Trajectory Scenario 2 (T2): vehicle speeds up to pass the intersection (e.g., to catch up the end of the green phase) and then returns to initial speed after the intersection (blue line);
- Trajectory Scenario 3 (T3): vehicle slows down and stops at the intersection (red line);
- Trajectory Scenario 4 (T4): vehicle slows down and passes the intersection with a mid-range speed, and then speeds up to its initial speed after the stop-bar (yellow line).



**Fig. 1.1 Illustration of different vehicle trajectories approaching an intersection**

Even though all these different trajectories cover the same distance with identical initial and final velocities, the associated fuel consumption and emissions may vary greatly. Vehicle 1 (or T1) uses the least fuel since there are very few changes in speed (neither acceleration nor deceleration). Vehicle 2 (or T2) consumes more fuel than vehicle 1 since slight acceleration and deceleration maneuvers occur right before and after the intersection. Vehicle 3 (or T3) uses the most amount of fuel since it has to decelerate to a full stop, idle for a certain amount of time, and then accelerates from zero to its initial speed. Finally, the fuel consumption of Vehicle 4 (or T4) and T2 is less than T3 since both vehicles have avoided larger speed-up and slow down maneuvers. In general, as a vehicle

travels along a signalized corridor, it would be better to speed-up or slow-down in advance if maintaining current speed cannot guarantee its passing through the intersection(s) within green phase(s). As the vehicle approaches a signal, its velocity should be dynamically adjusted to reduce fuel consumption and emissions.

In the study by PATH at UC Berkeley, a six-scenario taxonomy is quantitatively defined based on a more explicit indicator. The scenario indicator is given by

$$\gamma = \frac{\text{Required Average Speed to Pass}}{\text{Current Speed}}$$

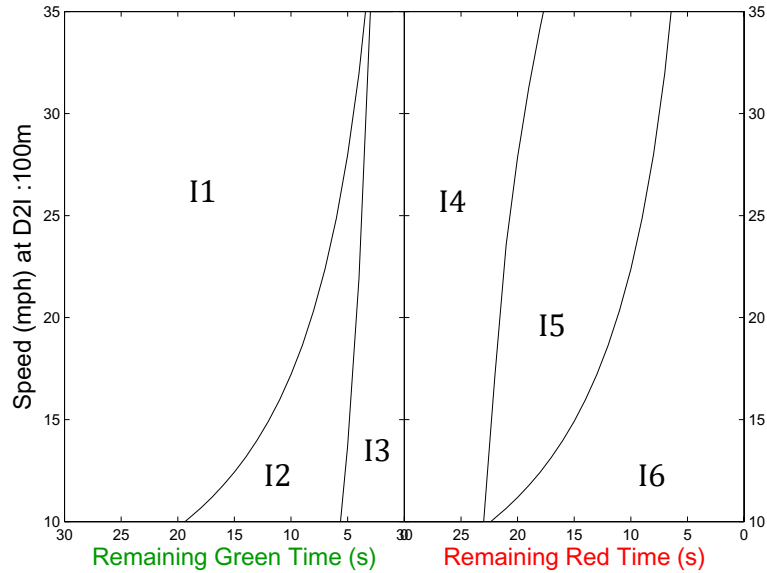
$$= \frac{\text{Distance to Intersection} / \text{Time to Signal Change}}{\text{Current Speed}} \triangleq \frac{D2I}{T2C * v_c}$$

Then the signal-related vehicle statuses are classified into six **Instantaneous Scenarios** by setting the thresholds of the above indicator. The six Instantaneous Scenarios are listed along with their relation to the four Trajectory Scenarios in the table below.

**Table 1.1 Determination of Instantaneous Scenarios**

| Current State | Scenario Indicator Range         | Instantaneous Scenario Description | Trip Scenario |
|---------------|----------------------------------|------------------------------------|---------------|
| Green         | $\gamma < \alpha_g$              | I1: Maintain speed to pass         | T1            |
|               | $\alpha_g \leq \gamma < \beta_g$ | I2: Speed up to pass               | T2            |
|               | $\gamma \geq \beta_g$            | I3: Have to stop                   | T3            |
| Red           | $\gamma \leq \beta_r$            | I4: Have to stop                   | T3            |
|               | $\beta_r < \gamma \leq \alpha_r$ | I5: Reduce speed to pass           | T4            |
|               | $\gamma > \alpha_r$              | I6: Maintain speed to pass         | T1            |

The parameters  $\alpha_g, \beta_g$  and  $\alpha_r, \beta_r$  stand for the boundary coefficients of scenario indicator, which can be empirically determined by D2I and speed data to distinguish the different scenarios.



**Fig. 1.2 Scenario partitions with respect to the initial speed and time to signal change**

Apparently, using fixed boundary coefficients to differentiate the scenarios may not apply to various conditions of speed and acceleration. By applying the maximum comfortable acceleration/deceleration to the approaching model, a desirable partition of scenario zones on an S-T plane (S: initial vehicle speed, T: time to signal change) is presented in Fig. 1.2. Simply from the partition of scenario zones, a system designer can find out what (signal) timing is effective for each EAD recommendation.

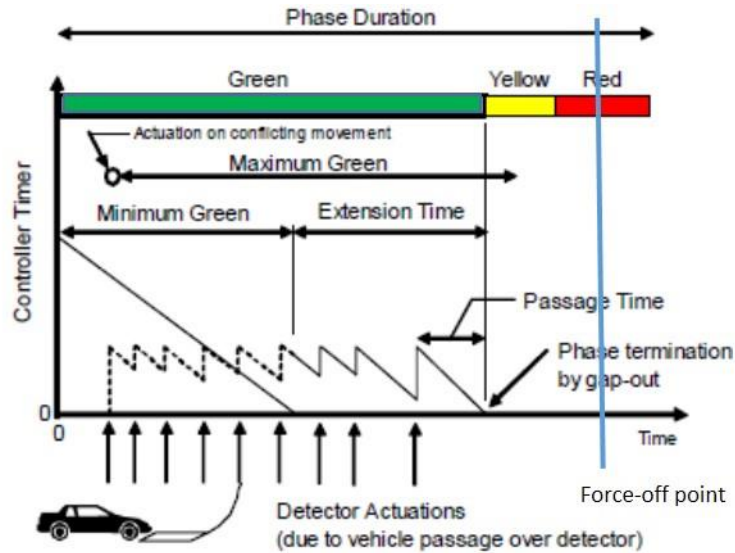
Regarding the relation between Instantaneous Scenario and Trip Scenario, the scenario I1 and I6 are at different time phases of T1, first I6 then I1, or simply within I1 when passing through; while the scenarios I3 and I4 are at different time phases of T3, first I3 then I4, or simply within I4 when slowing down to stop. For the other two scenarios, I2 corresponds to T2, and I5 corresponds to T4, which can only occur in the green or red phase, respectively.

Another viewpoint about the relationship between these two types of scenarios is: the Instantaneous Scenario could be changed during the approaching period by the driver's action, while the Trip Scenario is the result of the entire intersection drive-through process. The shift among different Instantaneous Scenarios will be examined as one approach to explain the motive of eco-driving, which is described and analyzed in Section 5.1.

### **1.2.2 Actuated Signals and Their Remaining Time Estimations**

The test bed uses Model 2070 controllers running Caltrans Traffic Signal Control Program (TSCP) to control the traffic signals. The traffic signal control system operates in coordinated-actuated mode, where the coordinated phases (phase 2 and 6 – El Camino Real through movement phases) are guaranteed to be served during each signal cycle while others (the minor or non-coordinated phases – left-turn and cross-street through movement phases) are actuated. The green interval of an actuated phase consists of a minimum green time followed by a green extension time, as illustrated in Fig. 1.3.





**Fig. 1.3 Green Interval of an Actuated Phase (Source: [7])**

The minimum green time is fixed while the green extension time depends on vehicle actuations on that phase. Each vehicle actuation adds a passage time to the green interval. The green phase is terminated according to one of the three mechanisms:

- A passage time elapses without a vehicle actuation (the phase is gapped out);
- The maximum green time for that phase is exceeded (the phase is maxed out); or
- The *force-off* point of that phase has been reached (the phase is forced-off).

The force-off points are fixed time points within a cycle where non-coordinated (actuated) phases must end regardless of continued demand to ensure that the coordinated (non-actuated) phases are served at the appropriate time such that progression for the major-road through movement is maintained. The calculation of force-off points depends on settings of the control plan (i.e., phase sequence and green split), and yellow-change and red clearance intervals.

Under the coordinated-actuated traffic signal control, if there is no “call” or demand on actuated phases, the coordinated phase remains green (crossing its force-off point); if an actuated phase terminates before using all its split allocation, the spare time can be reassigned to its following phases within the cycle; the spare time from all actuated phases is reassigned to the coordinated (non-actuated) phases. Therefore, the start and end of the green interval for each phase are not fixed time point within the cycle, so does the duration of the green interval itself.

The estimation of phase remaining time starts with the active phases and loops through other phases by ring and barrier, based on the phase sequence. For an active actuated green phase, the minimum time-to-change is calculated with respect to the end of its guaranteed green interval (e.g. minimum green or pedestrian walk plus flashing don't walk depending on the *active interval*), and the maximum time-to-change is calculated with respect to its max-out point or force-off point, depending on which comes first. For an active non-actuated green phase, both the minimum and maximum time-to-change are calculated with respect to its force-off point. The minimum/maximum start time for the

next phase on the same ring is the sum of the minimum/maximum time-to-change of the active phase, its yellow-change interval, and its red clearance interval. The same logic applies to non-active phases (currently in red) except the end of its guaranteed green interval is estimated based on *Vehicle Call*, *Pedestrian Call* and phase recall settings. When the changing of phase involves a barrier cross, the time-to-change for that phase is adjusted such that phases on two rings will cross the barrier simultaneously. The phase timing parameters (minimum green, maximum green, yellow-change and red clearance intervals), phase recall settings, and control plan parameters (phase sequence and split) are static intersection configuration data, which are polled from the Model 2070 controller. The force-off points are then calculated for each of the coordination plans. When the control plan number changed, these parameters (phase timing parameters, recall settings and control plan parameters) are polled from the controller again to ensure that the parameters in use are consistent with those used by the controller.

### **1.2.3 Driver Vehicle Interface Design**

It has been well-established that driver behavior can greatly affect vehicle fuel consumption [8], and research has suggested that there is a positive relationship between fuel efficient driving and positive safety outcomes

[15][17]. However, most of the recent research on eco-driving has focused on how to influence driver behavior towards reducing fuel consumption. Strategies to influence driver behavior have included pre-trip planning to encourage the use of public transit, post-trip feedback to encourage consolidating future short trips and highlight inefficient behaviors such as speeding or hard accelerations, and in-trip feedback aimed at reducing fuel consumption with real-time data displays. Some of the recent and ongoing major eco-driving projects include the following:

- Nissan CARWINGS (2008)
- Fiat eco:Drive (2010)
- Foot-LITE European Consortium (2007-2011)
- European Commission's eCoMove Project (Cooperative Mobility Systems and Services for Energy Efficiency) (2010-2013)
- European Commission's EcoDriver Project (2011-2015)
- U.S. Department of Transportation's AERIS (Applications for the Environment: Real-Time Information Synthesis) Project (2010-2015)
- University of California's Eco-Way Eco Navigator Project (2013)

Additionally, the National Highway Transportation Safety Administration (NHTSA) funded several U.S. studies concentrating primarily on OEM fuel economy driver interfaces [17] [20]. These studies were motivated by the fact that eco-driving driver interfaces were becoming increasingly more prevalent and complex, and not much information was known about either how to design these types of interfaces or about the potential effects that these types of interfaces might have on driver distraction.

### 1.2.3.1 Taxonomy of Eco-Driving DVI

Based on the reviewed literature and prior eco-driving projects, eco-driving DVIs have fallen into three general paradigms: post-trip feedback, instantaneous feedback, and feed-forward or prescriptive advice. The post-trip feedback strategy provides the driver with a report card on their recent driving while the instantaneous feedback and feed-forward advice aims to provide the driver with real-time tools to drive more efficiently on a moment-to-moment basis. As described in Hof, et al. [16], there has been much research on the effectiveness of various eco-driving feedback strategies. Post-trip and instantaneous feedback are thought to be more effective than simply providing eco-driving educational materials, but drivers can also begin to tune out instantaneous feedback over time, reverting to their previous behavior. Keeping the driver's interest over time may require the implementation of multiple timely strategies.

#### *Post-Trip Feedback*

Early eco-driving projects tended to focus on post-trip feedback since that type of data can be more easily recorded, processed off-line, and presented to the drivers at their convenience. The post-trip feedback method is based on the assumption that drivers will review their prior data, learn from that data, improve their fuel efficient driving skills, and track their improvement over time. Examples of the types of information provided to drivers in the various post-trip feedback paradigms reviewed are described below:

- Basic trip summary statistics such as average MPG, fuel used (gal), CO<sub>2</sub> emitted, average speed, top speed, time above a certain speed, overall trip time, and percent of time spent idling;
- An integrated (multiple metric) report card, score, or index of driver behavior related to either saving or wasting fuel such as hard acceleration/deceleration events, early or late gear changes, and time at constant speed;
- Personalized tutorials on how to achieve better fuel economy based on the driver's previous data;
- Aggregated monetary fuel costs based on travel patterns;
- Improvement over time and comparisons of driving performance across trips or tanks of fuel;
- Fuel savings or waste compared to some notion of poor, average, or optimal driving style;
- Social media and on-line communities where drivers can boast their scores or fuel savings;

#### *Instantaneous Feedback*

Instantaneous eco-driving feedback, in the form of an MPG (Miles Per Gallon) display, has been available on many vehicle models over the years, and most of the recent eco-driving projects reviewed incorporated some form of instantaneous eco-driving feedback to the driver. By providing feedback while driving, the information can be made more salient and can more easily be incorporated into corrective actions by the driver. The feedback could be framed as positive, highlighting when the driver is doing something correctly, or negative, highlighting when the driver is doing something incorrectly.

It should be noted that in the context of this taxonomy, the term “instantaneous” is being used to describe when the feedback is given to the drivers, and not necessarily the nature of the information given to the drivers. As an example, instantaneous eco-driving feedback might include the presentation of time-averaged fuel consumption over some recent period of time, not just the instantaneous fuel economy. Examples of the types of information provided to drivers in the various instantaneous feedback paradigms reviewed are described below:

- Current fuel economy (MPG)
- Time-averaged fuel economy (over the past few minutes, trip, or tank of fuel)
- Current acceleration rate (coded with a suggested maximum rate for efficient driving)
- Accelerator pedal counter force feedback
- Gear upshift indicator or optimal gear feedback
- Overall fuel conservation performance
- Last event performance (such as the last acceleration event)

#### Feed-Forward Advice

Only a few of the reviewed studies incorporated feed-forward or prescriptive eco-driving advice. While instantaneous feedback describes how the driver is currently or has recently been performing, feed-forward advice is used to instruct the driver on how to perform a future driving maneuver. Feed-forward eco-driving advice has been in a number of different scenarios. Typically, the feed-forward advice was given whenever there is an impending speed change and instructed the driver to begin coasting earlier than would a conventional driver. The advice might be given during an intersection approach or on an approach to a curve with a reduced speed, and one of the more novel interfaces reviewed provided a recommendation to begin coasting before cresting a hill.

- Suggested speed (for fuel conservation, curve ahead, or to catch a green light)
- Accelerator pedal pressure and coasting advice
- Suggested acceleration profile
- Distance countdown to, or map depiction of, future speed or acceleration changes (such as a speed limit reduction, curve, or hill crest)
- Current traffic signal status and time to signal change
- Predicted fuel savings gained by following the recommended speed or deceleration advice
- Adaptive navigation (using fuel-saving routes that avoid congestion)

#### 1.2.3.2 DVI Examples in Previous Studies

##### NHTSA Eco-Driving Studies

NHTSA funded two studies on fuel economy driver interfaces. The first NHTSA study on fuel economy driver interfaces [17] surveyed OEM and a few aftermarket products, but at the time of this study, very few aftermarket eco-driving assistants were available. Eco-driving interfaces varied widely from vehicle to vehicle, including both analog and digital

gauges, bar charts, indicator lamps, text displays, and even complex, high-resolution, LCD graphic depictions on some hybrid-electric vehicles.

Fig. 1.4 shows two qualitative eco-driving displays, one from Kia and the other from Honda. In the Kia display, the ECO icon located within the speedometer on the instrument panel changes from red, to yellow, to green to indicate inefficient, normal, or efficient driving. In the proposed Honda display, the speedometer background was shown in blue when the vehicle was being driven inefficiently, and the background slowly changed to green when the vehicle was driven in a more fuel efficient manner.



Kia Instantaneous Qualitative Feedback



Honda Time-Averaged Qualitative Feedback

**Fig. 1.4 Simple Qualitative Eco-Driving Feedback**

Overall, the recommendations from the NHTSA report can be summarized in the following four points:

1. Present multiple types of information simultaneously, including instantaneous information on how to modify the immediate driver behavior.
2. Graphical and symbolic depictions of fuel consumption are better than text.
3. Horizontal bar graphs work best for fuel consumption, but bar graphs should have meaningful labels to indicate good versus poor performance.
4. Present information that allows drivers to improve their fuel economy, rather than simply displaying current behavior (i.e., current acceleration).

#### eCoMove Project

The eCoMove (Cooperative Mobility Systems and Services for Energy Efficiency) project was sponsored by the European Commission from 2010 to 2013, and it focused on integrated green-mobility solutions including concepts such as a virtual driving coach, eco trip planning, and eco traffic control and management. Although there were many aspects to the project, the primary work concerning eco-driving user interfaces included a survey of drivers regarding the types of eco driving interfaces that they might find appealing

[14] and a simulator experiment looking at an intersection eco-driving assistant [22].

In the traffic light scenario depicted (left image of Fig. 1.5), the system was indicating that the vehicle should begin coasting because the driver is approaching a traffic light that will turn to red in 9 seconds. When approaching a traffic signal, the system advised the driver

to maintain a constant speed if the vehicle was able to pass through the intersection on the green without stopping, or if the traffic signal was red, the system advised the driver to begin coasting early enough to lose about 20% of their speed before braking, which sometimes resulting in the driver slowing enough to catch the green light and continue without stopping. In the curve scenario depicted (right image of Fig. 1.5), the system was indicating that a sharp curve is approaching in 150 m, but the driver is already travelling at the recommended speed because the needle is in the green range.



**Fig. 1.5 eCoMove Intersection (Left) and Curve (Right) Eco-Driving Assistant**

Overall, the eco-driving assistant resulted in a smoother driving style, with more constant velocities and softer accelerations and decelerations, but only a little less than half of the participants were able to save fuel using the interface, averaging 16 to 18 percent gains in the targeted scenarios. However, participants often remarked that the system instructed them to slow down too soon, especially when the scenario required a full stop such as at a stop sign. On post-test rating scales, the interface was reported to be easy to use and useful, but also potentially distracting.

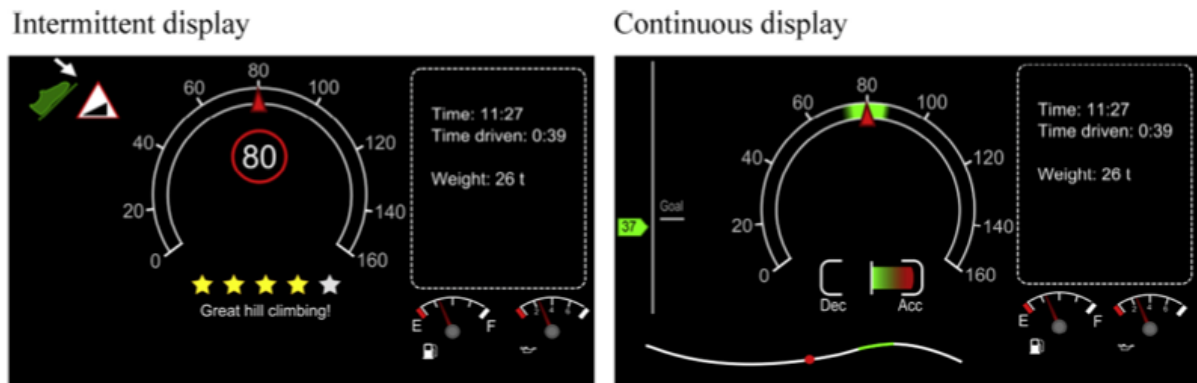
#### ecoDriver Project

The ecoDriver project was sponsored by the European Commission from 2011 to 2015 including multiple academic and industry partners across the EU. Within this project, there was a large focus on eco-driving feedback, advice, and strategies, along with eco-DVI design solutions to maximize eco-driving system effectiveness and acceptance [16][23][24]. One of the first ecoDriver project reports reviewed the state of the art in eco-driving support systems, including both OEM (Audi, Scania, Porsche, Honda, Nissan, BMW, Daimler, VW, and Fiat) and aftermarket equipment (TomTom, Garmin, and others). Most of the reviewed systems provided the driver with a visual interface, several supplemented the visual interface with auditory alerts, and a few also included haptic feedback such as through the accelerator pedal. The feedback provided by the various systems related to metrics such as speed, acceleration, or fuel economy. Some of the more interesting conclusions related to eco-DVI design included:

- Horizontal bars with reference points are thought to be more easily identifiable than dials;
- Graphics are preferred over text;

- Instantaneous acceleration has not been found to improve driver performance over simply providing a measure of the instantaneous fuel economy;
- The more automatic the system, the more it will be used consistently by the driver;

An example of the two types of displays tested is shown in Fig. 1.6 [18]. The intermittent display (left) consisted of three components: a feed-forward accelerator pedal icon instructing the driver to accelerate or coast (upper left), a recommended speed (circled text), and post-event feedback (a 5-star rating based on driver performance). The continuous display (right) provided a continuously changing recommended speed band (on the speedometer), instantaneous feedback on accelerator/brake pedal pressure (horizontal bar graph below the speedometer), an average fuel consumption meter (vertical bar graph on the left), and a feed-forward display of where or when the driver should apply acceleration (bottom). The display was mounted center-high on the dashboard, replacing the normal speedometer.



**Fig. 1.6 Intermittent vs. Continuous Eco-Driving Display.**

Overall, the project aimed to take a comprehensive approach to eco-driving, targeting pre-trip behavior and providing in-trip and post-trip feedback, as well as examining driver-related factors (driving style, individual motivations, and personalization) and even feed-forward advice (such as advice about upcoming speed limit changes or a haptic accelerator pedal with knowledge of upcoming road gradients). To achieve these goals, multiple simulators and on-the-road experiments were planned [24] and conducted [23] to test various eco-DVI design concepts, to look at driver learning effects and transfer of training from one scenario to another, and finally, to examine skill degradation over time once the eco-driving feedback is removed. The main driving scenarios considered during the studies included acceleration, deceleration, constant-speed driving, and driving with gradients, but some of the individual studies did include limited eco-driving advice at intersections. The experiments that were conducted relating to eco-driving DVI designs are detailed in the subsequent sections.

## 2 Framework of Eco-Approach and Departure System

In this section, the system framework is presented for a comprehensive understanding of the architecture and fundamental mechanism of the entire system, which contains the descriptions of both infrastructure and test vehicle, and information exchange through V2I communication as well.

### 2.1 Overview of DSRC Supported Traffic Signal System

#### 2.1.1 DSRC Applications and Components

The Dedicated Short Range Communications (DSRC) offers different modes of V2I and V2V communication, not limited to safety application. The interactions between infrastructure and approaching vehicles have become more feasible and attractive for different potential applications, which are summarized in the table below.

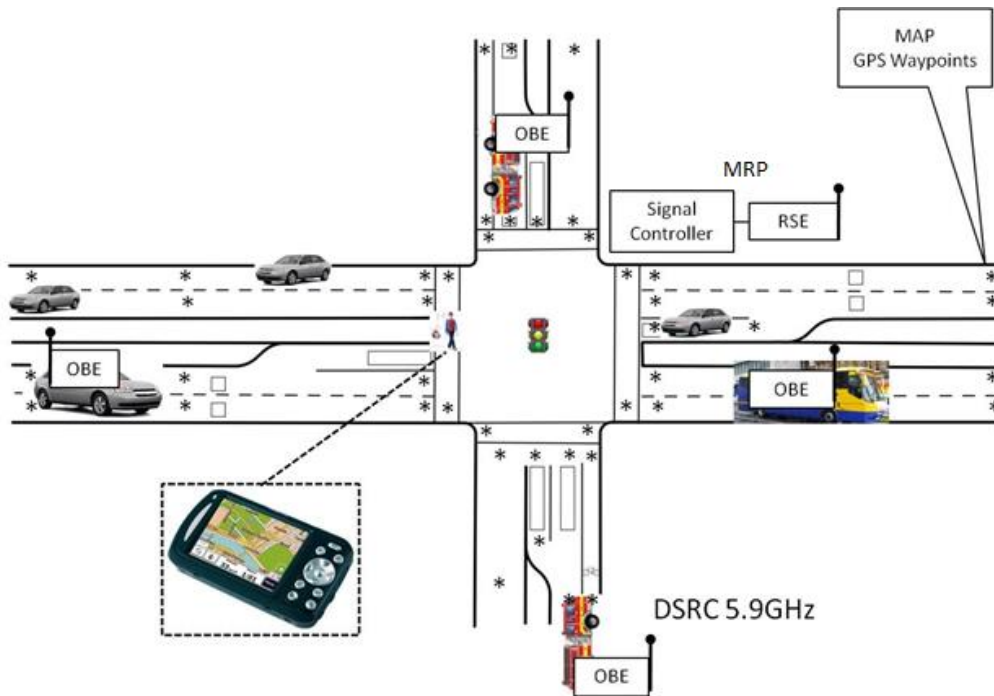
**Table 2.1 Typical applications of DSRC**

|   | Information Provider | Information Consumer | Main Information Utilized         | Application                  |
|---|----------------------|----------------------|-----------------------------------|------------------------------|
| 1 | Infrastructure       | Vehicle              | Emergency Notice or Bulletin      | In-Vehicle Signing           |
| 2 | Intersection         | Vehicle              | Signal Timing                     | Smooth Driving (Eco-Driving) |
| 3 | Intersection         | Vehicle              | Traffic Map                       | Driving Guide                |
| 4 | Vehicle              | Intersection         | Location, Trajectory and Priority | Control Optimization         |
| 5 | Vehicle              | Infrastructure       | Incident Report                   | Emergency Warning            |
| 6 | Vehicle              | Vehicle              | Relative Kinetics                 | Safety Warning               |
| 7 | Vehicle              | Roadside             | Parking Status                    | Electronic parking payment   |
| 8 | Infrastructure       | Station/Stop         | Real Time Transit Information     | Transit Info Service         |

In all the applications based on DSRC, the following devices and messages are commonly used in different context including the EAD project. The frequencies normally adopted for each message are also noted as below.



- OBU:** On-Board Unit
- BSM:** Basic Safety Message (10 Hz)
- SRM:** Signal Request Message (1 Hz)
- RSE:** Roadside Equipment
- MAP:** Geographic Intersection Description (1 Hz)
- SPaT:** Signal Phase and Timing (10 Hz)



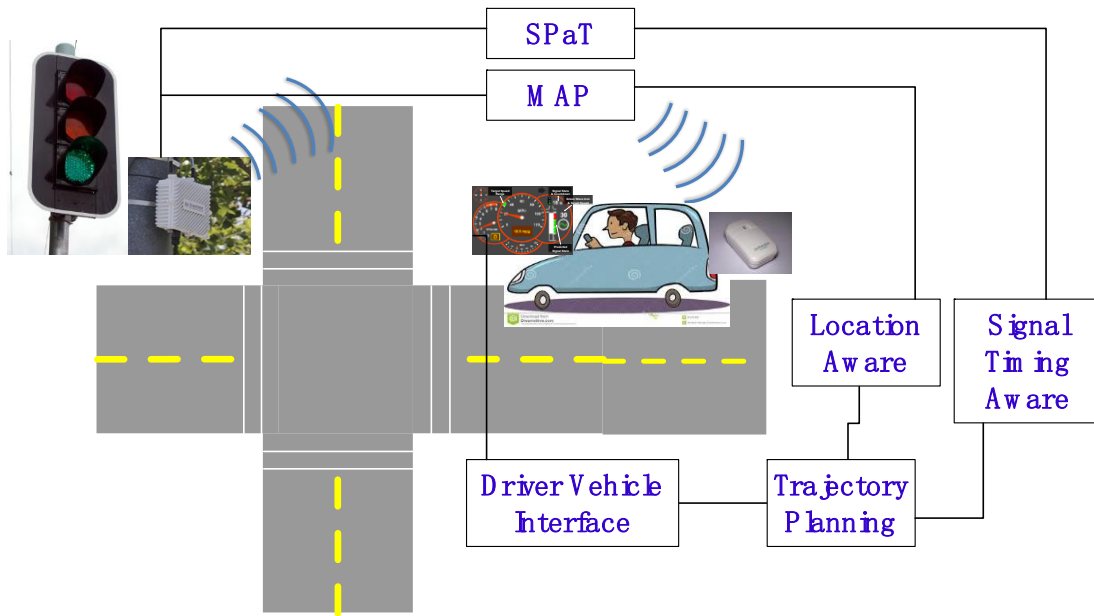
**Fig. 2.1 DSRC components at a signalized intersection**

### **2.1.2 Diagram of EAD Application**

For the EAD application, the main effective information from which the system benefits can be categorized into three perspectives:

- **Timing:** the signal remaining time contained in messages of SPaT, especially for the actuated signal at intersections;
- **Location:** the real time geographic location projecting on an intersection map, including the driving direction, lane, distance to/passed stop line;
- **Observable Parallel Traffic:** the relative distance, velocity of the preceding vehicle, and the queue length for some particular scenarios.

Fig. 2.2 presents the basic framework and its processing flow of EAD application. The details of each part are described based on this diagram and will be described in the corresponding sections.



**Fig. 2.2 Information flow of EAD application**

## 2.2 Overview of Infrastructure

### 2.2.1 Field Test Corridor

The California Connected Vehicle Test Bed is the nation's first DSRC test bed, which became operational in 2005 with the aim of assessing real-world implementations of Vehicle Infrastructure Integration (VII). Currently this test bed is part of the National Connected Vehicle Test Bed and conforms to the latest technology standards and architecture of U.S DOT's Vehicle-to-Vehicle (V2V) and Vehicle-to-Infrastructure (V2I) research program and is on a 4G LTE backhaul. The Test Bed is supported by Caltrans and the ITS Joint Program Office (JPO) within the Research and Innovative Technology Administration (RITA). It supports cutting-edge research in the Connected Vehicle safety, mobility and environment related applications, services and components. The Test Bed utilizes state-of-the-art DSRC devices and provides the capability to evaluate safety, mobility, and environmental applications. The test bed spans 11 consecutive intersections along a 2-mile stretch of the highly travelled arterial of El Camino Real (SR-82) in Palo Alto, California. The location is close to many of the auto OEM research labs and the Silicon Valley.

The salient features of the test bed and some relevant capabilities are listed below.

- Upgraded DSRC enabled test bed: A sequence of consecutive blocks along El Camino Real from the intersection of Stanford to Charleston in Palo Alto is equipped with the updated hardware and software that are compatible with IEEE 1609 and SAE J2735;
- Linked security server: The test bed is linked to the security server of USDOT managed by Leidos (formerly SAIC) so that communication security protocols can be exercised;

- Signal Phase and Timing (SPaT) information: For intersections along the El Camino Test Bed, the information can be acquired by DSRC radios as vehicles drive, while other locations can be provided through cellular communication;
- Dedicated intersection computer to augment local computing capability;
- IPv6 connectivity to national as well as local servers via 4G backhaul;
- Detailed intersection maps are available as MAP (GID info.) broadcasts in a standardized form.



**Fig. 2.3 Test bed at El Camino Real**

Table 2.2 lists the 11 consecutive signalized intersections, from the northern end to the southern end, with the GPS location of the intersection (center of the intersection) and route distance between consecutive intersections.

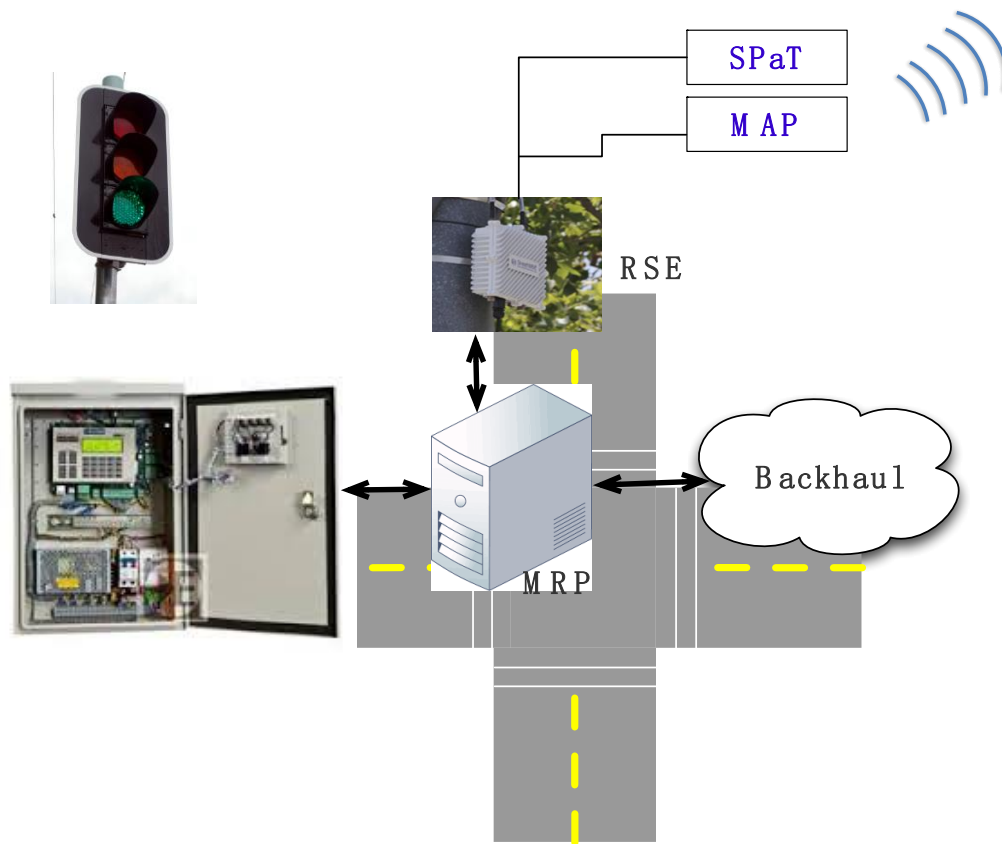
**Table 2.2 List of intersection along California test bed (from north to south)**

| Intersection ID | Intersection Name | Distance to the next Intersection (m) | Latitude | Longitude  |
|-----------------|-------------------|---------------------------------------|----------|------------|
| 1000            | Stanford Ave      | 320                                   | 37.42777 | -122.14922 |
| 1001            | Cambridge Ave     | 48                                    | 37.42559 | -122.14678 |
| 1002            | California Ave    | 464                                   | 37.42510 | -122.14590 |
| 1003            | Page Mill Rd      | 400                                   | 37.42305 | -122.14205 |
| 1004            | Portage/Hansen    | 384                                   | 37.42117 | -122.13843 |
| 1005            | Matadero Ave      | 368                                   | 37.41919 | -122.13451 |

|      |                |     |          |            |
|------|----------------|-----|----------|------------|
| 1006 | Curtner Ave    | 125 | 37.41762 | -122.13160 |
| 1007 | Ventura Ave    | 211 | 37.41684 | -122.13006 |
| 1008 | Los Robles Ave | 528 | 37.41574 | -122.12815 |
| 1009 | Maybell Ave    | 176 | 37.41202 | -122.12464 |
| 1010 | Charleston Rd  | -   | 37.41044 | -122.12331 |

### 2.2.2 Setup of Intersection Facilities

The function of intersection facilities is to collect the signal timing and to transmit SPaT and MAP messages out with the DSRC protocol. The flow of information is straightforward, from the signal controller, calculating at the MRP server, forwarding to the RSE, and then broadcasting over the air.



**Fig. 2.4 Intersection facilities**

The consecutive intersections on the El Camino Real corridor are coordinated, which means the entire system is controlled from a master controller and is set up in the way that lights "cascade" (progress) in sequence in order that platoons of vehicles can proceed through a series of green lights. From the perspective of the control mode, Fully Actuated Control is usually used at an isolated and non-coordinated intersection, while Semi-Actuated Control is used for a coordinated system. Under semi-actuated (coordinated)

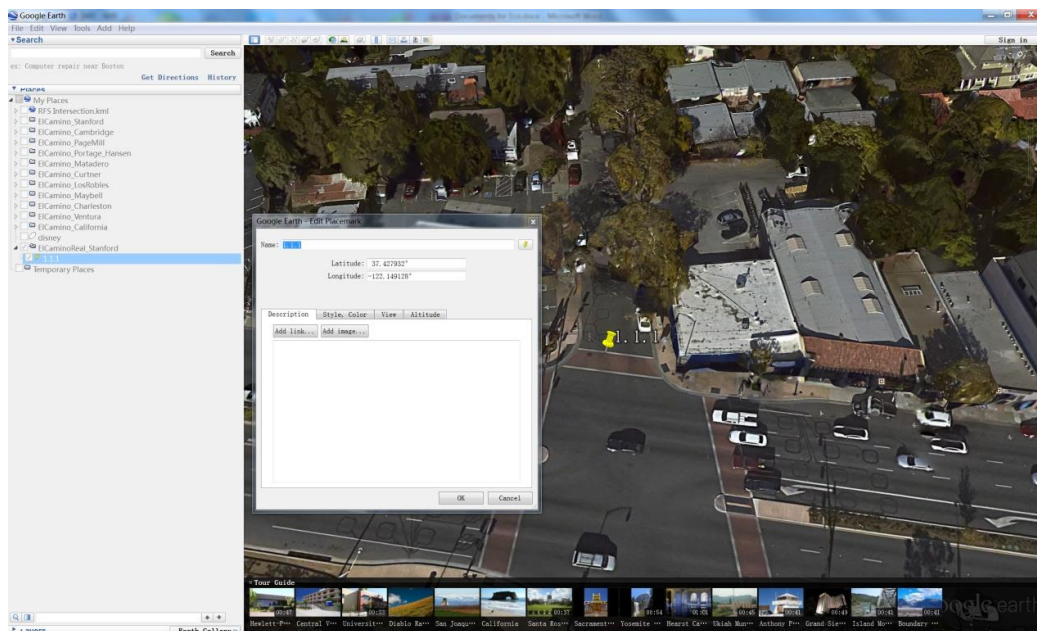
control, non-coordinated phases (left-turn movements and side-street movements) vary their lengths in response to vehicular and pedestrian demands, measured by embedded loops and pedestrian pushbuttons. When serviced, the length of a non-coordinated green phase varies between the minimum and imposed maximum for coordination; phase start time also varies depending on the time the call is present.

However, in this project, the coordination has not been fully utilized to benefit the fuel consumption. The only coordination information used is the coordinated phase timing that helps to estimate the remaining time for the current signal phase (see Sect. 1.2.2).

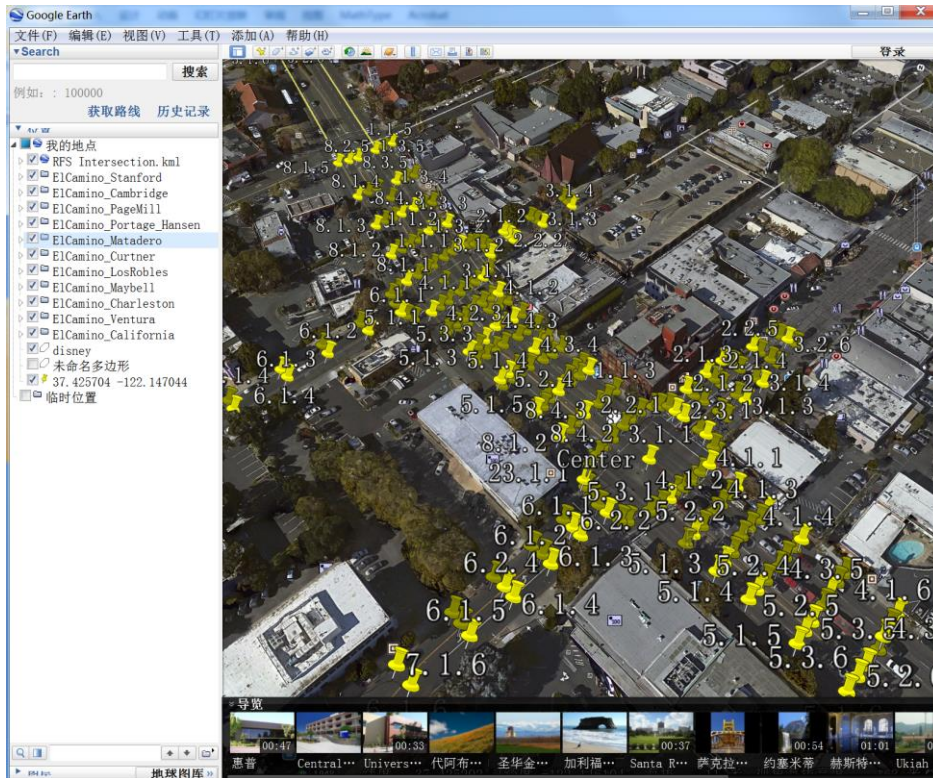
### 2.2.3 Geometric Intersection Description

The Geometric Intersection Description (GID) is a particular kind of intersection map in the form of a standard message for the applications of entry localization, tracking and navigation. The GID nMap contains the information of intersection elements, which are approaches, lanes and reference nodes listed in sequence.

Instead of the field plotting, online map tools such as *Google Earth* can be used to obtain the geometric properties of every intersection in a visible way.



(a)



(b)

Fig. 2.5 Plotting of intersection GID map

All the GID information is recoded into a “nmap” text file, and each file contains map(s) of either one intersection or several intersections, which contains all the information needed for constructing J2735 MAP messages. The first six (6) lines of the file must contain the following fields:

Table 2.3 The structure of nmap file header

| Field Name              | Example                        | Comments   |
|-------------------------|--------------------------------|--|
| MAP_Name                | El_Camino_and_Ventura.nmap     | Up to 80 characters                                      |
| RSU_ID                  | El_Camino_Ventura              | Up to 80 characters                                      |
| IntersectionID          | 1007                           | Must be greater than 255                                 |
| Intersection_attributes | 00110011                       | See <b>Intersection_attributes</b> section of J2735 NMAP |
| Reference_point         | 37.4168366 -122.1300875<br>126 | Latitude Longitude Altitude<br>(degree degree meter)     |
| No_Approach             | 8                              | Number of approaches described in this file              |

Following the first six lines, there are "No\_Approach" (8 in this case) groups of approach descriptions. Each approach description begins with the "Approach" field and ends with the "end\_approach" terminator in a single line. Each approach description contains

"No\_lane" (in this case, 3) lane descriptions. Each lane description begins with the "Lane" field and ends with the "end\_lane" terminator in a single line.

**Table 2.4 The structure of each approach in an nmap file**

| Field Name               | Example                 | Comments  |
|--------------------------|-------------------------|---|
| Approach                 | 3                       | El Camino NB Ingress, the 3rd approach of a intersection  |
| Approach_type            | 1                       | 1: approach; 2: egress  |
| No_lane                  | 4                       | Number of Lanes   |
| Lane 3.1                 | 6                       | The first lane of Approach 3  |
| Lane_ID                  | 1                       | The ID of this lane   |
| Lane_type                | 1                       | motorized vehicle lane, see <b>Lane_type</b> section of J2735   |
| Lane_attributes          | 0101010                 | not egress path, straight and right turn permitted, turn on red, no U-turn, see <b>Lane_attributes</b> of J2735 |
| Lane_width               | 330                     | in cm   |
| No_nodes                 | 6                       | Number of nodes   |
| 3.1.1 (node ID)          | 37.4168468 -122.1298819 |   |
| 3.1.2                    | 37.4167836 -122.1297681 |   |
| 3.1.3                    | 37.4167236 -122.1296547 |   |
| 3.1.4                    | 37.4166540 -122.1295159 |   |
| 3.1.5                    | 37.4165758 -122.1293615 |   |
| 3.1.6                    | 37.4164897 -122.1292010 |   |
| No_Conn_lane             | 2                       |   |
| 8.1 (connection Lane ID) | 4                       | Straight through, see <b>Connected_lanes</b> section of J2735 NMAP defs snippet.docx                            |
| 2.1                      | 3                       | Right turn  |
| end_lane                 |                         | Lane description terminator   |
| Lane 3.2                 |                         |   |
| ...                      |                         |   |
| end_lane                 |                         |   |
| ...                      |                         |   |
| end_approach             |                         | Approach description terminator   |

The steps of creating an nmap file are briefly proposed as below.

- Step 1: Start the GoogleEarth Program

Support Software: GoogleEarth or GoogleEarth Professional

- Step 2: Create a new folder in “My Places”  
Folder Name: intersection or nmap name
- Step 3: Add new Points of Interest (POI) to the folder  
Click “Center Point”, select the “Approach”, then “Lane”, then “Node” from the road side to the center
- Step 4: Save the folder data to file  
File Name: use intersection name; File Type: use “.kml”
- Step 5: Extract the POIs coordinate  
Support Software: “MapDataConvert.exe”; Output File Type: “.txt”
- Step 6: Edit the text file and output  
Output File Type: “.nmap”; Reference: “nmap” data format documents
- Step 7: Test and verified the “nMap” file  
Support Software: “MapTest.exe”

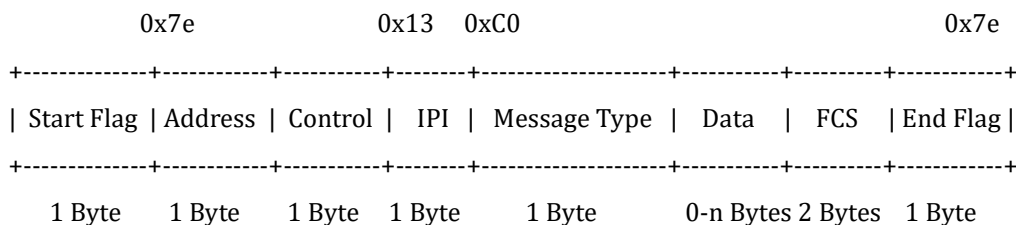
#### 2.2.4 *SPaT and MAP Messages*

The data elements, data frames, and messages in SAE J2735 message sets over DSRC (Dedicated Short Range Communications) are defined in terms of a formal language called Abstract Syntax Notation One (ASN.1). The J2735 dictionary standard also calls for use of the Distinguished Encoding Rules (DER) to translate the ASN.1 into a concrete data stream. Encoding and decoding of J2735 messages were developed based on J2735 ASN.1 Specification, revision number DSRC\_R36 [9].

##### SPaT Message

The SPaT (Signal Phase and Timing) message is broadcast at 10 Hz rate and provides the current status of the signal indications being displayed for all movements on each approach of the intersection, as well as the phase remaining time (i.e., time-to-change to the next state). The current status of the signal indications is obtained directly from the Caltrans 2070 controller with AB3418 protocol over serial RS-232 communications, while the phase remaining time is estimated based on the current status, phase timing parameters (including pedestrian walk, pedestrian flashing don't walk, minimum green, maximum green, passage, yellow-change and red clearance), phase recall settings (including vehicle minimum recall, maximum recall, and pedestrian recall), and control plan timing parameters (including cycle length, phase sequence and split).

AB3418 messages are variable length and have the following format:

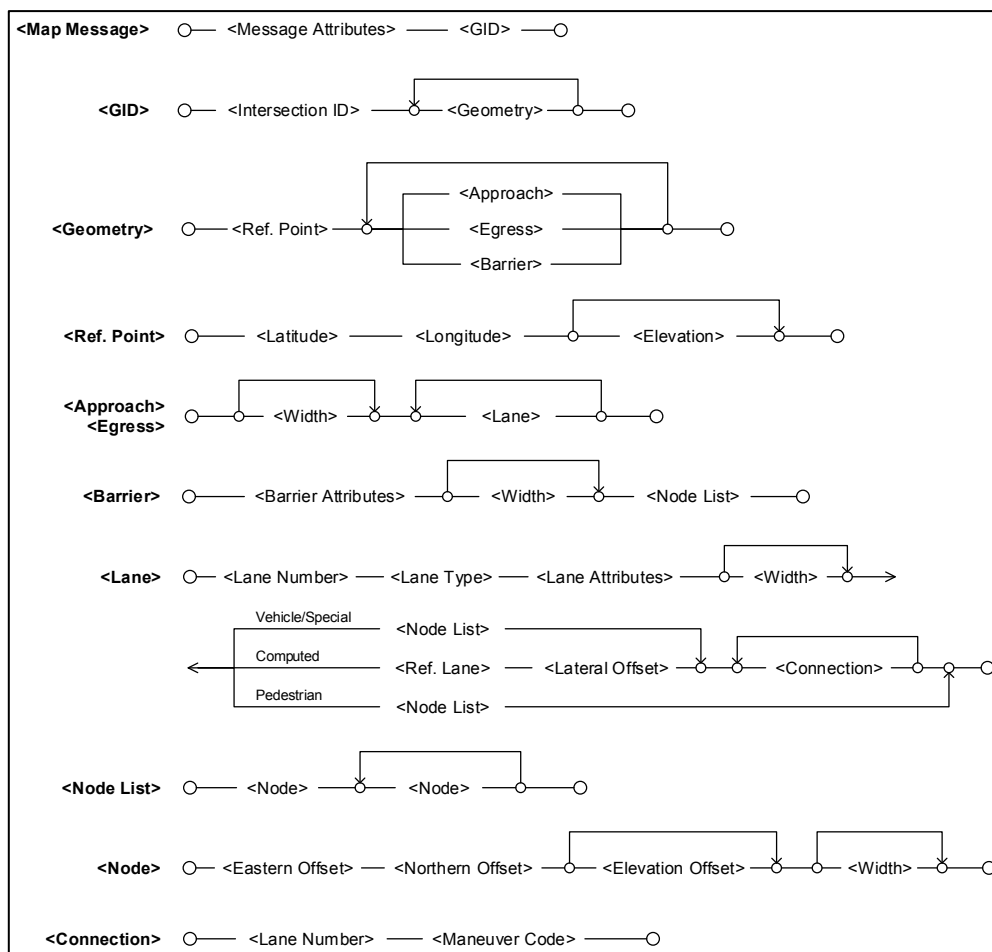




Caltrans TSCP (Traffic Signal Control Program) running on the Model 2070 traffic controller supports *Message Get* (Message Type = 0x87) and *Message Set* (Message Type = 0x96) to read and modify TSCP memory blocks. In order to facilitate constructing SPaT messages, Caltrans Division of Traffic Operations (TrafficOps) modified TSCP to push out a *signal\_status* message at a rate of 10 Hz on serial port C20S. The definition of data fields of *signal\_status* message is shown in the AB3418 protocol. The *active\_phase* and *active\_interval* data elements determine the current status of signal indication being displayed for all movements, while other data elements are used for the estimation of phase remaining time for all movements. More particularly, *pedestrian call* and *vehicle call* data elements hold the information about which phase has received a vehicular and/or a pedestrian service call. Combining with *Permissive Periods* and *Ped Permissive Periods*, it can be estimated whether the call phase is going to be served within the current cycle or in the next cycle, such that the appropriate phase green start and end time point can be estimated based on received service calls.

### MAP Message

The MAP message provides the geometric intersection description (GID) data that defines a digital map of an intersection down to the lane level [10].



**Fig. 2.6 MAP Data Objects**

The MAP message is broadcast at 1 Hz rate and describes the static geometry of the intersection in terms of approaches within an intersection, lanes that belong to each approach and associated vehicle movements (e.g. through, right-turn, left-turn, etc.), and way points (nodes) that defines each lane. The structure of data objects that comprise the MAP message is illustrated in Fig. 2.6.

## 2.3 Overview of Test Vehicles

### 2.3.1 *PATH Test Vehicle*

The test vehicle was established based on a five-seat Nissan ALTIMA car, which has been tested and verified to be suitable for researches related to fuel consumption and V2I communication.

#### 2.3.1.1 Devices On Board

For the purpose of evaluation for intersection eco-driving application, the test vehicle was equipped with Data Acquisition System containing several groups of sensors and devices, which are:

- Embedded Computer

Function: to accomplish information acquisition as the system input, to obtain the real time vehicle location (“LocationAware”) and the signal timing (“SignalAware”), to calculate the advisory speed trajectory based on the temporal-spatial relation between the vehicle and intersection, to display the suggested information to the driver as the system output.

- Single precision GPS

Function: to determine the geographic coordinate of the test vehicle, which can be used to calculate its relative location to the approaching intersection.

Connection Port: RS232 serial port to the embedded computer.

- Sensors on board

Function: to provide the vehicle motion parameters of speed, fuel consumption, and other assistant control parameters.

Connection Port: to access CAN bus and send data to the embedded computer via CAN2USB adapter.

- Radar Sensor

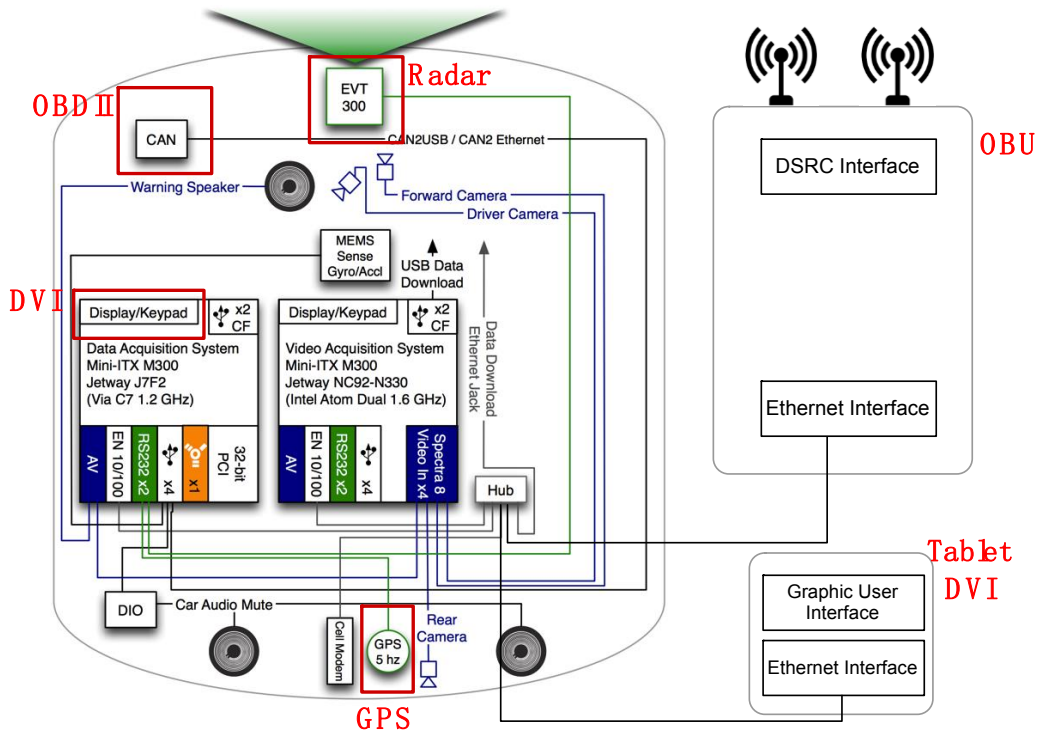
Function: to obtain the distances in between and relative velocities of the frontal vehicles, among which the preceding vehicle is of most importance for the fuel saving application.

Connection Port: RS232 serial port to the embedded computer.

- On Board Unit (OBU)

Function: DSRC communication module on board, to send Basic Safety Message (BSM) over the air, and to receive SPaT messages and MAP messages from the air, following the SAE J2735 protocol.

Overall, the connection diagram of all the devices on board is illuminated in Fig. 2.7.



**Fig. 2.7 Diagram of test vehicle setup**

### 2.3.1.2 Database for Information Sharing

The project involves different kinds of information and the interaction in real time, which requires a data management tool for convenient sharing and storage. The in-memory database **DB\_SLV** has been used at PATH for many years for Inter Process Communications (IPC) on the embedded computer. This server allows client programs to share read- and write- access to structured variables, by sharing common header files where the index names of the variables and the structure types associated with these variable indexes are defined. The clients control the creation and deletion of variables; the server keeps track of the index value, the size of the variable, and what clients have asked to be notified when the variable's value is changed. The server ensures that once a variable has been created by one process, a second attempt to create it will receive an error. More than one process can read or even write a variable, and the reads and writes will be serialized at the server, so that they remain atomic. Since these are reads and writes to the server, not to a file, there is no disk I/O.

The in-memory database of embedded computer utilized for eco-driving application is described in Table 2.5.

**Table 2.5 In-memory database (Datahub) variable description**

| Datahub | Database variable  | Relevant measurements                                 | Variable ID |
|---------|--------------------|---|-------------|
| GPS     | DB_GPS_PT_LCL      | longitude, latitude, heading, gps speed               | 8021        |
| Radar   | DB_EVT300_RADAR1   | target ranges, target azimuths, target speeds         | 5001        |
| CAN bus | DB_ALT_VS          | vehicle speed,  | 905         |
|         | DB_ALT_GI          | gear,   | 904         |
|         | DB_OBD2_MAF        | mass airflow rate,                                    | 908         |
|         | DB_OBD2_CER        | (CER)   | 909         |
| DSRC    | DB_SAVARI_OBU_SPAT | SPAT message  | 701         |
|         | DB_SAVARI_OBU_MAP  | MAP message   | 702         |
| DVI     | DB_DVI_AII         | approaching intersection info.                        | 2001        |
|         | DB_DVI_IFC         | fuel consumption info.                                | 2002        |
|         | DB_DVI_VSD         | vehicle speed for display                             | 2003        |
|         | DB_DVI_PTOC        | predicted time to signal change                       | 2011        |
|         | DB_DVI_PPOS        | predicted Pass or Stop                                | 2012        |
|         | DB_DVI_ETAS        | estimated time to pass and the corresponding advisory | 2013        |

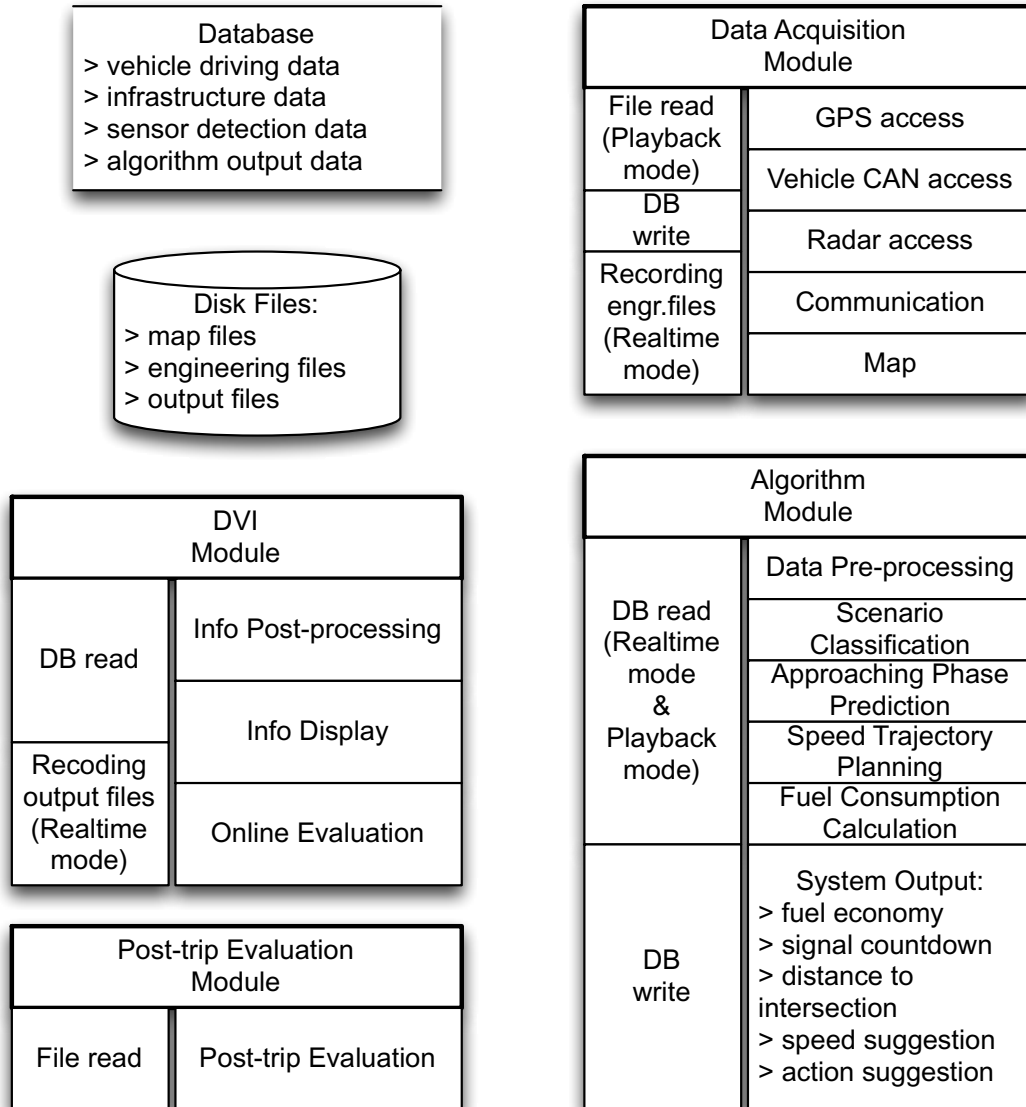
### 2.3.1.3 Algorithm Architecture of On-Board Embedded Computer

The main algorithms running in the on-board embedded computer can be classified into five modules according to their functions, which are described as:

1. Data acquisition module, accomplishing the functions of
  - GPS data acquisition and database storage;
  - Vehicle CAN bus data acquisition and database storage;
  - Radar data acquisition and database storage;
  - SPaT and Map data acquisition (no access to database)
2. Vehicle location and signal estimation module, accomplishing the functions of
  - Vehicle Location Awareness
  - Signal Remaining Time Awareness
3. Trajectory planning module, accomplishing the functions of
  - Scenario Classification
  - Speed trajectory optimization based on fuel consumption prediction
4. DVI elements generation and display module, accomplishing the functions of
  - Transform from algorithm results to DVI element values
  - Graphic User Interface management

5. Database and engineering file management module, accomplishing the functions of
- Databub management
  - Maintaining engineering files containing vehicle location tracks, OBD-II data, DSRC messages, radar data, etc.
  - File playback and post-trip evaluation

The architecture of these modules is illustrated in Fig. 2.8.



**Fig. 2.8 Algorithm components of on-board system**

### 2.3.2 UC Riverside Test Vehicle

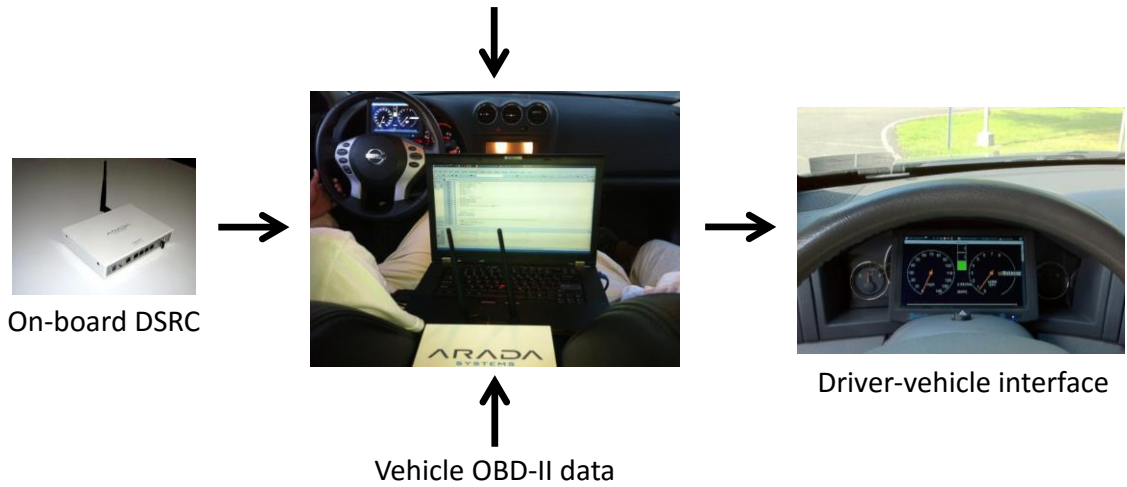
At UC Riverside, a 2008 Nissan Altima research test vehicle was set up to perform the eco-approach and departure application testing, as shown in Fig. 2.9. This vehicle was equipped with a DSRC modem to receive both the GPS information and signal phase and timing (SPaT) messages, an on-board diagnostics (OBD) connector to retrieve the



**Fig. 2.9 Test vehicle: a 2008 Nissan Altima**



Radar detection data



**Fig. 2.10 In-vehicle components**

vehicle's high resolution dynamics information in real-time, a radar installed on the front bumper to detect the activities of preceding vehicles (within the detection range), an on-board computer to compute the velocity trajectories and determine if the advisory speed information should be presented or not, and a 7-inch automotive-grade display to serve as an artificial dashboard (see Fig. 2.10).

In this system architecture, the on-board computer carries out a number of tasks, including:

1. Parsing the SPaT and GID messages received from the DSRC modem at 10 Hz;
2. Acquiring high-resolution vehicle dynamics data (e.g., instantaneous speed and RPM) from the CAN BUS via OBD-II Pro;
3. Estimating the vehicle's distance-to-intersection based on its location and a developed map-matching algorithm;
4. Processing the radar detection data to estimate several key parameters (e.g., relative distance, relative speed) related to the preceding vehicle (along the same lane);
5. Calculating an energy efficient velocity trajectory based on the algorithm described in Sect. 3.2;
6. Delivering key information to the driver through the artificial dashboard display.

### 3 Trajectory Planning Algorithms

A branch of speed management research involves Intelligent Speed Advisory (ISA) [25]. Early research on ISA was oriented toward providing optimal speed advice to drivers aiming to improve safety [26]-[29]. However, its users benefitted from reduced fuel consumption and emissions due to smoother driving speed and more stable traffic conditions (e.g. [30] and [31]). Servin et al. described the preliminary research carried out to better understand the energy consumption and vehicle emission impacts of the implementation of the ISA on freeway traffic [30]. They also suggested that the ISA implementations can be divided into fixed, variable and dynamic types based on how the set speed is determined, and they can also be categorized as advisory, active support and mandatory based on how it intervenes with driver's behavior. From an energy/emission stand point, ISA-related research laid the foundation for eco-driving systems, which refers to driving in an ecological and economical way in terms of providing speed advisories for drivers.

The trajectory planning algorithms serve as the kernel component of the system, which is implemented and provides the entire approach and departure ideal trajectory either at some critical distance points or at a predefined frequency.

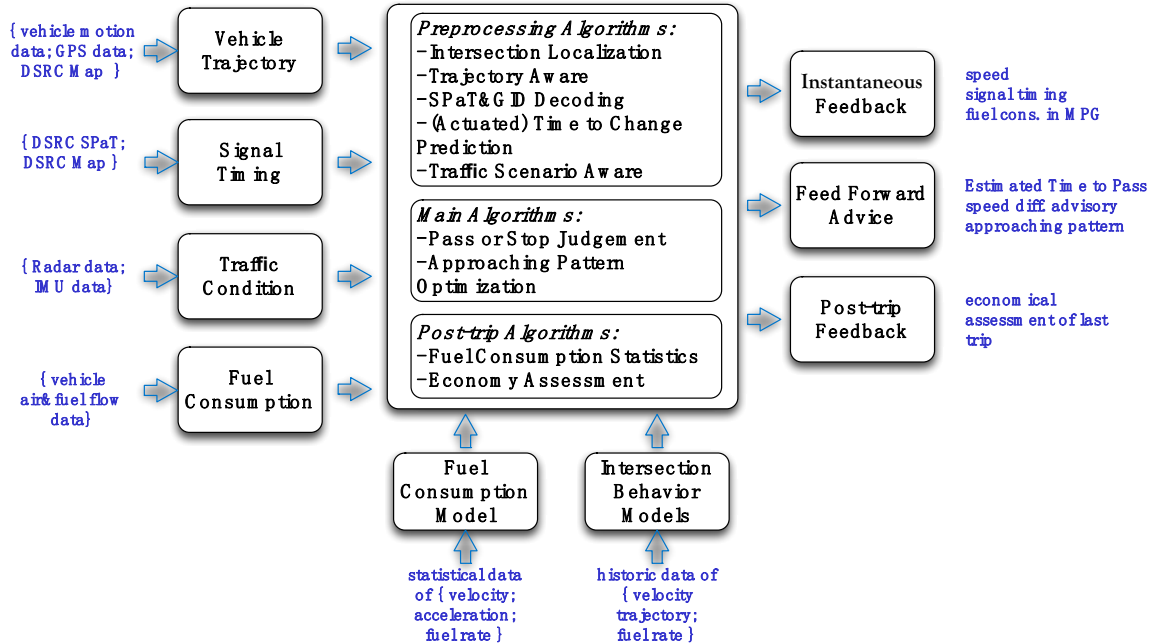
#### 3.1 Approach I (UC Berkeley)

The trajectory planning algorithm is the essential component of EAD system, no matter whether the vehicle is controlled by a human being or will automatically be driven in the future. Once an ideal speed trajectory has been planned, any kinds of suggestions to the driver, such as target speed, suggested headway, or advisory acceleration/brake action, can be drawn from the planned trajectory.

In our algorithm, the planned trajectory firstly can be seen as a realizable upcoming trip despite of the driver's behavior, then the modeling of the driver's response and feedback will be considered into the entire processing. For the clarity of explanation, we'd like to decompose the algorithm into four successive parts:

- Modeling of fuel consumption and vehicle behavior at intersection, serving as the "*offline input*" to the system;
- Real time awareness on vehicle's spatial-temporal position (relative location and signal remaining time) related to approaching intersection, serving as the "*online input*" to the system;
- Speed trajectory planning based on the fuel consumption model, vehicle behavior model, vehicle's real time location and estimated signal remaining time, serving as the *main algorithm* of the system;





**Fig. 3.1 Architecture of algorithm**

- Advisory information abstracted and obtained from the planned trajectory, serving as the “information output” from the system;

which are respectively described in the following subsections.

### 3.1.1 System Offline Input: Fuel Consumption Modeling

Instead of many mathematical models of the instantaneous fuel rate, we formulated a group of empirical equations that describe the function relationship between the fuel consumption rate and the instantaneous speed and acceleration based on statistical samples, given by

$$FuelRate = f(v_{inst}^d, a_{inst}^c)$$

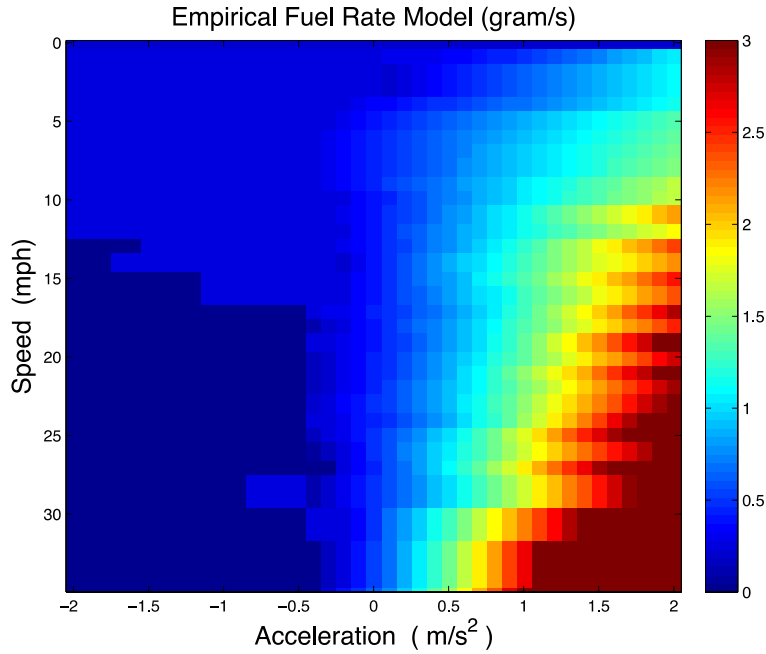
The instantaneous values of the three factors were obtained by the following means in Table 3.1.

**Table 3.1 Measures of fuel consumption model**

|                                | Equation                     | Source         | Definitions and Units   |
|--------------------------------|------------------------------|----------------|---|
| Instantaneous Speed            | $v$                          | OBDII, CAN bus | Integer valued speed, in mph  |
| Instantaneous Acceleration     | $v_{t+0.5} - v_{t-0.5}$      | By calculation | Continuous valued acceleration, in m/s  |
| Instantaneous fuel (mass) rate | $MAF \times CER/AFR_{ideal}$ | OBDII, CAN bus | MAF: Mass Air-Flow rate, in grams/sec<br>CER: Fuel/Air Commanded Equivalence Ratio, dimensionless |

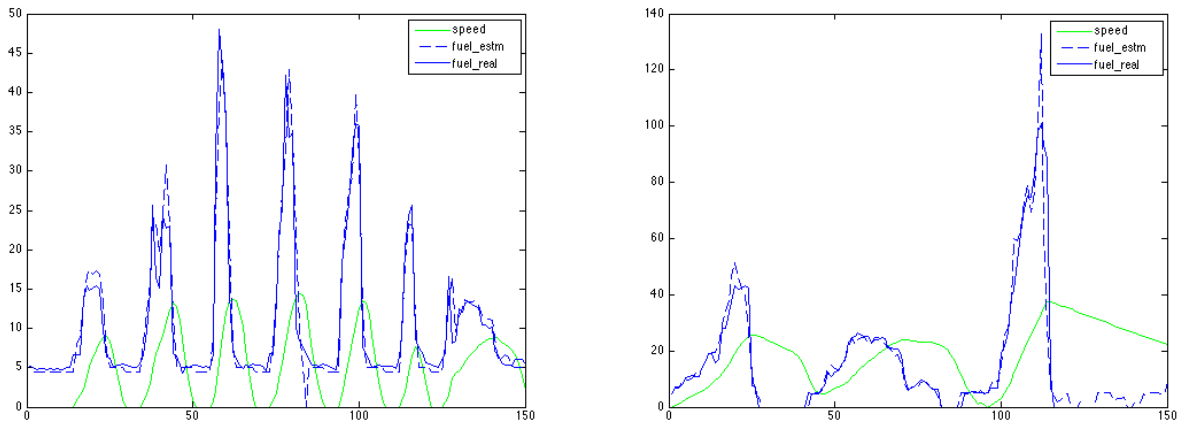
|  |  |  |  |
|--|--|--|--|
|  |  |  | AFR: Air-Fuel Ratio, 14.7 for the ideal value, dimensionless |
|--|--|--|--|

The function relationship between these three measures is illustrated by a pseudo-color image in Fig. 3.2, where the speed ranges from 0 to 40mph and the acceleration ranges from  $-2\text{m/s}^2$  to  $2\text{m/s}^2$ . Note that the figure can only be valid for the Nissan Altima test car and under the condition of driving on normal flat roads.



**Fig. 3.2 Empirical fuel flow rate model**

The matching of model based estimation and field collected data under different driving profiles has also verified the reliability of this empirical model, which are shown in Fig. 3.4 below.



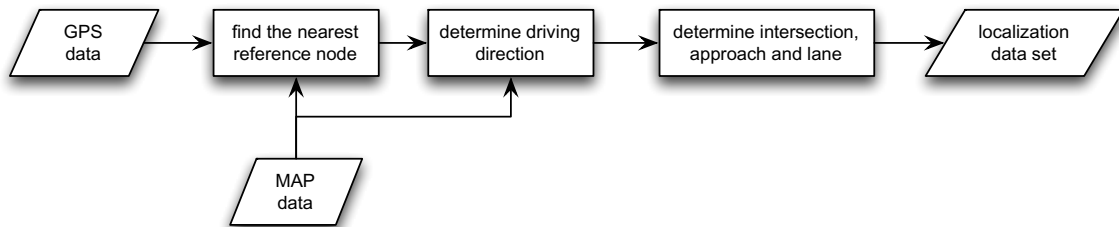
**Fig. 3.3 Matching of the empirical model and real fuel flow rates**

### 3.1.2 System Online Input: Vehicle Location and Signal Timing

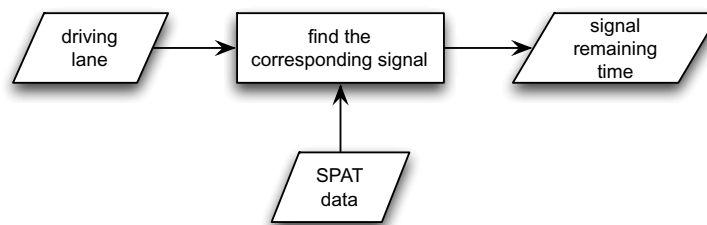
No matter what kinds of recommendations (or advisory information) would be given to the driver, the essentials of intersection eco-driving are providing upcoming signal timing information to help the driver make upfront action in order to save fuel. Therefore, the fundamental inputs are from two groups, which are:

- Vehicle Localization (*LocationAware*, Fig. 3.4)
  1. Approaching intersection (intersection ID)
  2. Driving lane (lane number)
  3. Location area (NOT\_IN\_MAP, ON\_APPROACH, AT\_INTERSECTION\_BOX, ON\_EGRESS)
  4. Current distance to intersection stop line (D2I, in meter)
- Intersection Signal Timing (*SignalAware*, Fig. 3.5)
  5. Current signal phase (red, green or yellow)
  6. Signal remaining time (in second)

Obviously, getting signal timing relies on the current driving lane that is one of the results of vehicle localization, while vehicle localization is a widely implemented program of continuously projecting a vehicle in motion to its approaching intersection.



**Fig. 3.4 Processing flow of *LocationAware* program**



**Fig. 3.5 Processing flow of *SignalAware* program**

There are many factors that can affect the performance of vehicle localization, such as the number and coordinates of reference nodes, the optimization method of finding the nearest intersection, the choice of algorithm with or without tracking, and the particular processing of vehicle heading at low speed. In this project, the balance between high performance and processing speed was addressed after numerous field tests.

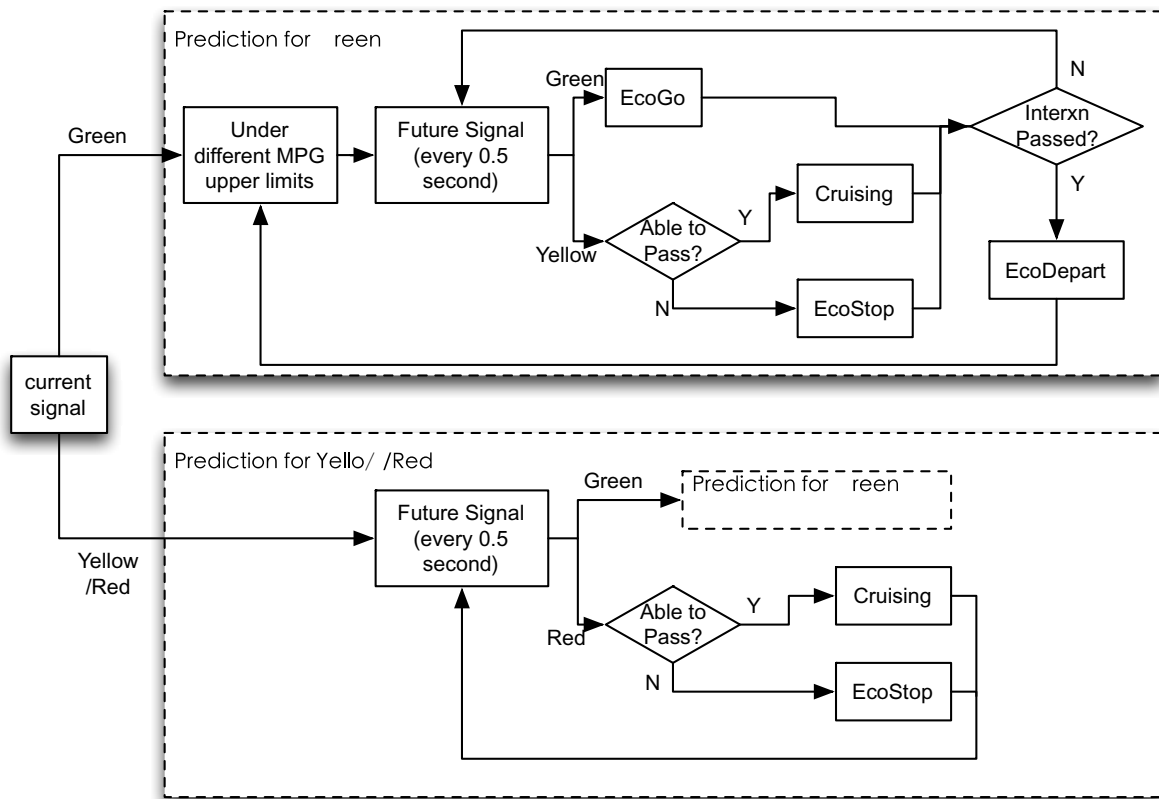
### **3.1.3 Speed Trajectory Planning Algorithm**

Eco-driving involving traffic signals is relatively promising in the near future, primarily because much of the existing supporting technology today can be readily applied [32]. Evidently, maintaining a constant velocity and avoiding unnecessary stops, accelerations and decelerations are the key principles behind eco-driving [33]. Green Light Optimal Speed Advisory (GLOSA) Systems utilize the SPaT information from the traffic signal controllers to forecast the traffic light status and generate a fuel-optimal speed trajectory for drivers based on the current state (e.g. vehicle position and speed) of a vehicle. In 1983 Zimdahl introduced a first speed advisory system which makes use of traffic light information [34]. Infrared equipped traffic lights inform the drivers of approaching vehicles of an appropriate speed. However, technical difficulties and low profit ratios led to discontinuation of this project [35]. Koukoumidis et al. leveraged windshield-mounted smartphones and their cameras to collaboratively detect and predict the schedule of traffic signals, enabling GLOSA and other novel applications [36]. Test results show that fuel savings is up to 20.3 percent on average by using the GLOSA application on smartphones. Asadi et al. proposed the use of upcoming traffic signal information within the vehicle's adaptive cruise control system to reduce idling time at stop lights and fuel consumption [37]. They formulated an optimization-based control algorithm to minimize the probability of stopping at intersections. Simulation results show that the predictive use of SPaT information could save fuel and reduce CO<sub>2</sub> emissions up to 47% and 56% respectively, in driving through a sequence of nine traffic lights. Tielert et al. studied the parameters of traffic-light-to-vehicle communications which might have impacts on fuel consumption using microscopic traffic simulation [38]. Simulation results from this study show that the optimal distance for the activation of the eco-speed adaptation algorithm is 500m, and single-intersection scenarios yield a 22% reduction in fuel consumption while multi-intersection scenarios yield an 8% reduction. In [39] and [40], Seredynski et al. have demonstrated that during free traffic flow, a multi-segment GLOSA results in a much better performance when compared with a single-segment approach, while in another paper [41], they have shown that both single- and multi-segment GLOSA can improve bus ride comfort, as well as reduce fuel consumption and tailpipe emissions. The choice between the single- and multi-segment algorithms depends on the factors such as consistency and predictability of dwell time, and type of signal operation. Katsaros et al. also studied the parameters that could have impacts on fuel and traffic efficiency [42]. The simulation results suggest that the higher the GLOSA penetration is, the more benefits the system brings. Their conclusion on the optimal activation distance is 300m and it depends slightly on the road network. In [35], Eckhoff et al. identified the potential benefits and limitations of GLOSA systems. By simulation they found that at low traffic densities the GLOSA systems can reduce waiting time, stop times, travel time as well as CO<sub>2</sub> emissions whereas in dense traffic several side-effects can be observed. Most research is based on the assumption that the traffic signal has fixed timing, however a large portion of traffic lights is under traffic-responsive control in a real-world urban area. In [44]-[46], the authors studied the combination of the GLOSA with the adaptive traffic signals. In order to address this issue, Erdmann devises an AGLOSA algorithm which exploits V2I to extend the planning horizon and create sufficiently stable plans using dynamic programming [44]. The author states that the AGLOSA algorithm can reduce vehicle time-loss significantly when compared with

other algorithms. Bodenheimer et al. presented and validated a method to overcome the problem of combining GLOSA with adaptive controlled signal by forecasting fully and semi-adaptive traffic lights [45].

In the construction of the proposed algorithm, three basic rules were set up to establish the framework and constraints including:

1. To derive the advisory speed profile based on predicted Instantaneous Scenarios along the time axis (every 0.5 second);
2. The discrimination of scenarios and prediction of being able to pass or not are always more important than the numeric optimization of speed trajectory;
3. Never recommend actions obviously opposite to the current signal, including no speeding up during red even knowing the red phase is about to end, and no hard deceleration during green even knowing the green phase is about to end.



**Fig. 3.6 Diagram of speed trajectory planning algorithm**

The algorithm flow chart is shown in Fig. 3.6. The basic framework is the scenario prediction and speed optimization triggered by time axis. From the initial moment, the scenario of the entire trip is predicted every 0.5 second, by deriving the arrival status based on the initial speed and signal remaining time, according to which a number of candidate speed recommendations. The candidate recommendations are a set of possible speed trajectories from the current location to the intersection, and each trajectory is derived based on a single lower bound of instantaneous fuel efficiency (in Mile Per

Gallon). Among these candidate trajectories, the one resulting in the most economic fuel consumption will be chosen to be the final recommendation.

In the trajectory planning algorithm, three constraint factors are introduced into the optimization process including: 1. the speed limit (35mph on El Camino Real), 2. the maximum acceleration and deceleration, and 3. minimum cruising speed given parallel traffic.

### 3.1.4 Incorporating driver behavior model

As mentioned at the beginning of this section, both the recommendations that the driver received and the driver’s responsive actions will affect the final vehicle behavior. Therefore, there are two main works contributing to the final speed advisory algorithm, one is the speed trajectory planning algorithm presented in Sect. 3.1.3, another is the closed-loop model introducing the driver’s behavior feedback. The basic planning algorithm was generated in an empirical way, whereas the driver behavior model was derived by more theoretical methods.

The majority of studies on eco-driving have focused on the algorithms for generating optimized speed profiles. However, under actual driving conditions, it’s difficult and unsafe for a driver to exactly follow the so-called optimal speed trajectory. To the authors’ best knowledge, no research has been conducted to study the strategies to provide the speed advisory that does not require constant attention of the driver. In this project, we analyze this issue based on the current speed advisory model. We also improve the current model and simulations that were conducted with the results showing that the improved model could adapt to human driver’s behavior.

It is important to take into consideration that driver behavior is critical for designing a speed advisory model that can adapt to human drivers. Although significant research has been conducted on a driver’s car following model [47], they do not apply to the EAD research here, because the driver’s behavior of following a front car is totally different from following a speed trajectory. We use the proportional-integral-derivative (PID) function to simulate such kind of driver’s behavior due to its popularity and simplicity, and the most important is that the parameters of the PID function represent the human’s reaction rate towards present error, accumulation of past errors and a prediction of future errors [54].

To follow a desired speed, the driver’s behavior for controlling a vehicle could be a closed-loop control. The PID control diagram is shown in Fig. 3.7.

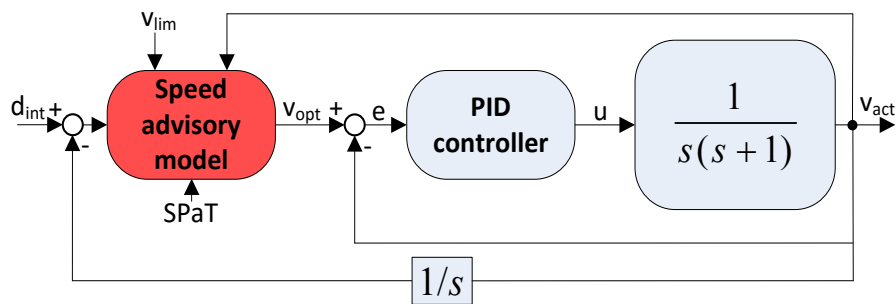


Fig. 3.7 Closed-loop speed advisory implementation

The input is the desired optimized speed  $v_{opt}$ , which is given by the speed advisory model. The error between  $v_{opt}$  and the actual speed  $v_{act}$  is denoted by  $e$ . The control parameter  $u$  is the desired acceleration/deceleration that the driver responds to the speed error. A full vehicle response model can be simplified when excluding the impact from the gear box. For acceleration controls, the full vehicle response can be simplified as two major parts which are the engine response and powertrain response respectively. In [48], the authors point out that manifold filling delay is the major delay that exists in the engine-response toward the driver's control on the throttle, while according to [49], the total powertrain of a vehicle can be considered stiff. For deceleration controls, the vehicle response can be regarded as the brake response. The brake model was studied in [50]. The authors pointed out that the time delay is an important factor in braking operations. Based on the data from a series of experiments conducted on the test bench of the brake subsystem, they found that the shape of the brake response can be approximated by a first order system. Since our research focus is on the strategy when the actual speed deviates from the suggested speed, rather than establishing an accurate vehicle response model, we choose a first order lag to simulate the delay feature of the vehicle's response to the driver's control input  $u$ , which is

$$\ddot{v}_{act}(t) + \dot{v}_{act}(t) = u(t) \quad (1)$$

with the transfer function

$$V_{act}(s) = \frac{1}{s(s+1)}U(s). \quad (2)$$

And the PID controller is

$$u(t) = K_p e(t) + K_i \int_0^t e(\tau) d\tau + K_d \frac{de(t)}{dt} \quad (3)$$

with

$$e(t) = v_{opt}(t) - v_{act}(t) \quad (4)$$

where  $\ddot{v}_{act}(t)$  and  $\dot{v}_{act}(t)$  are the second and first derivative of the actual speed  $v_{act}$ , respectively.  $K_p$ ,  $K_i$  and  $K_d$  are parameters of proportional, integral and derivative control respectively.

Combining the equations above, we obtain the transfer function between  $v_{opt}$  and  $v_{act}$

$$V_{act}(s) = \frac{K_d s^2 + K_p s + k_i}{s^3 + (k_d + 1)s^2 + k_p s + K_i} V_{opt}(s) \quad (5)$$

### Closed-loop Speed Advisory Implementation

All current research on speed advisory models assumes that drivers could follow the speed profile precisely. However, drivers only 'sample' the advisory information therefore deviations always exist between the actual and suggested speed trajectory in real world driving applications. This deviation should be shrunk so as to reach a higher fuel economy performance. But it is unrealistic to train all drivers to change their driving behavior to follow the suggested speed trajectory more closely. The only way is to make the speed

advisory adapt to the human driver's actual speed trajectory. By feeding back the actual speed trajectory, a closed-loop speed advisory model has been investigated in this paper.

The closed-loop implementation framework has already been shown in Fig. 3.7. In this case, the suggested speed  $v_{opt}$  updates at the frequency  $f = 1/T$ . At each time step  $k$ ,  $v_{opt\_k}(t)$  is designed for  $t \in [t_k, t_k + T]$ , with the initial conditions of

$$\dot{v}_{opt\_k}(0) = \dot{v}_{act\_k-1}(T) \quad (6)$$

$$v_{opt\_k}(0) = v_{act\_k-1}(T) \quad (7)$$

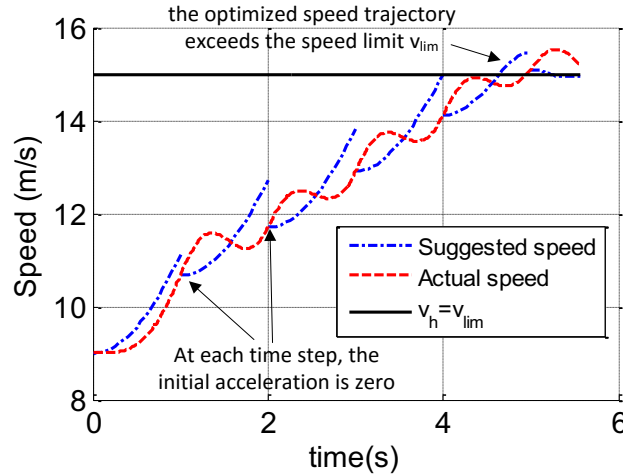
$$d_{int\_k}(0) = d_{int\_k-1}(0) - \int_0^T v_{act\_k-1}(t) dt \quad (8)$$

$$t_{r\_k}(0) = t_{r\_k-1}(0) - T \quad (9)$$

$$t_{g\_k}(0) = t_{g\_k-1}(0) - T \quad (10)$$

### Base model with closed-loop implementation

We conduct an example simulation using the following parameter settings:  $v_c = 9m/s$ ,  $v_{lim} = 15m/s$ ,  $d_{int} = 70m$ ,  $T = 1$ ,  $K_p = 20$ ,  $K_d = K_i = 0$ ,  $t_r = 6s$  and the current phase is green. The simulation result is shown in Fig. 3.8. Intuitively, some points that don't make sense can be found. First, the optimized suggested speed profile is not continuous in terms of acceleration. At each time step, the initial acceleration of the suggested speed trajectory is zero. This happens because there is no explicit acceleration parameter in the base model, so the acceleration value cannot be iterated using Eq. (6). Second, the actual speed trajectory shows frequent accelerations and decelerations, which indicates that the speed advisory system brings a great burden for the driver to follow the suggested trajectory. Also, it is shown that the suggested speed trajectory exceeds the speed limit  $v_{lim}$  at the end, which could make people feel that the speed advisory is not reliable enough.



**Fig. 3.8 An example trajectory of using the closed-loop base model**

The problems listed above indicates that the base model does not fit in the closed-loop implementation, and should be improved at least in the following two aspects. The first is the acceleration/deceleration parameter should be added to the speed profile functions



(i.e. eq. (2)) to make the acceleration/deceleration value capable of being iterated. The second is that  $v_h$  should not be simply defined as the minimum between  $v_{lim}$  and  $v_{ho}$ , because in acceleration profile designs, once  $v_h$  equals  $v_{lim}$ , the suggested speed profile must exceed  $v_{lim}$  according to the feedback model.

CAEHV model with closed-loop implementation

Based on the analysis above, we improve the model as is shown in Fig. 3.9 (left), with the acceleration/deceleration profile functions of

$$v_{opt}(t) = \begin{cases} v_h - v_d(t) * \cos(\mu t), & \text{for } 0 \leq t < \frac{\pi}{2\mu} \\ v_h - v_d(t) * \frac{\mu}{\rho} * \cos \rho \left( t - \frac{\pi}{2\mu} + \frac{\pi}{2\rho} \right), & \text{for } \frac{\pi}{2\mu} \leq t < \left( \frac{\pi}{2\rho} + \frac{\pi}{2\mu} \right) \\ v_h + v_d(t) * \frac{\mu}{\rho}, & \text{for } \left( \frac{\pi}{2\rho} + \frac{\pi}{2\mu} \right) \leq t \leq \frac{d_{int}}{v_h} \end{cases} \quad (11)$$

where  $v_d(t)$  equals to

$$v_d(t) = \begin{cases} v_h - v_c - a_0 * t, & \text{for } 0 \leq t < \frac{\pi}{2\mu} \\ v_h - v_c - a_0 * \frac{\pi}{2\mu}, & \text{for } \frac{\pi}{2\mu} \leq t \leq \frac{d_{int}}{v_h} \end{cases} \quad (12)$$

where  $a_0$  is the initial acceleration. For acceleration speed profiles,  $v_h$ ,  $\mu$  and  $\rho$  in Eq. (11) are unknown parameters that are subject to the following constraints:

$$\begin{cases} \rho = f(\mu, d_{int}, v_h, v_d(t)) \\ v_h + \left( v_h - v_c - a_0 * \frac{\pi}{2\mu} \right) * \frac{\mu}{\rho} = v_{lim} \\ |(v_h - v_c) * \mu * \rho| \leq 10 \\ \mu = \mu_{max} \end{cases} \quad (13)$$

Eq. (13) uses similar constraint functions of the base model except the second term, which restricts the high velocity limit as  $v_{lim}$ . For deceleration speed profiles the  $v_h$  is a known value. Both  $\mu$  and  $\rho$  are unknown and are subject to the constraint function Eq. (13) without the second term.

It has been shown from Eq. (11)-(13) that the new speed profile functions have included the initial acceleration variable  $a_0$  and have an explicit high velocity boundary. Also, by taking the derivative of Eq. (11), it is found that the acceleration profile  $a_{opt}(t)$  is a continuous function with the initial acceleration value  $a_{opt}(0)$  equals to  $a_0$ . Moreover, the suggested speed trajectory is restricted to be below  $v_{lim}$  for the entire period. According to these features, this model is entitled Continuous Acceleration with Explicit High Velocity boundary (CAEHV) model hereafter.

CAEHV-C model with closed-loop implementation

In order to tackle the problem of speed oscillations, which denotes an uncomfortable driving experience and a potential factor that could increase fuel consumption, further analysis on the CAEHV model has been conducted. The oscillations are caused by human driver's sluggish response and delayed action when the driver is advised to switch from acceleration to cruising. In real world driving, the oscillations could be avoidable if the driver is advised to switch from acceleration to coasting by taking his/her foot off the gas

pedal. Thus, we incorporated the concept of substituting the cruising command with the coasting advice when the vehicle attains a certain speed.

Based on the mathematical solution of vehicle coasting [54] we improve the CAEHV model as the CAEHV-C (CAEHV with Coasting) model, and its diagram is shown in Fig. 3.9 (right). Note that  $|a| \approx 0$  means that the vehicle is currently cruising.  $t_{coasting\_end}$  is the virtual arrival time when the vehicle reaches the intersection presumably by coasting.

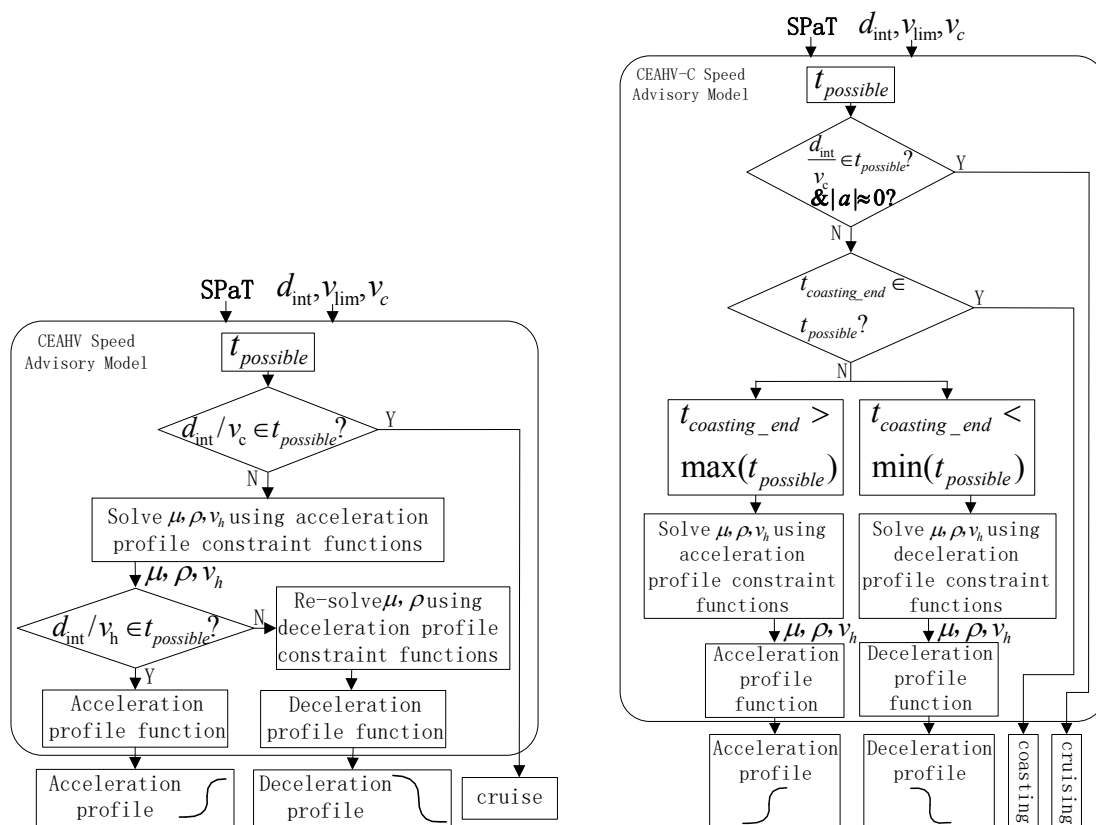


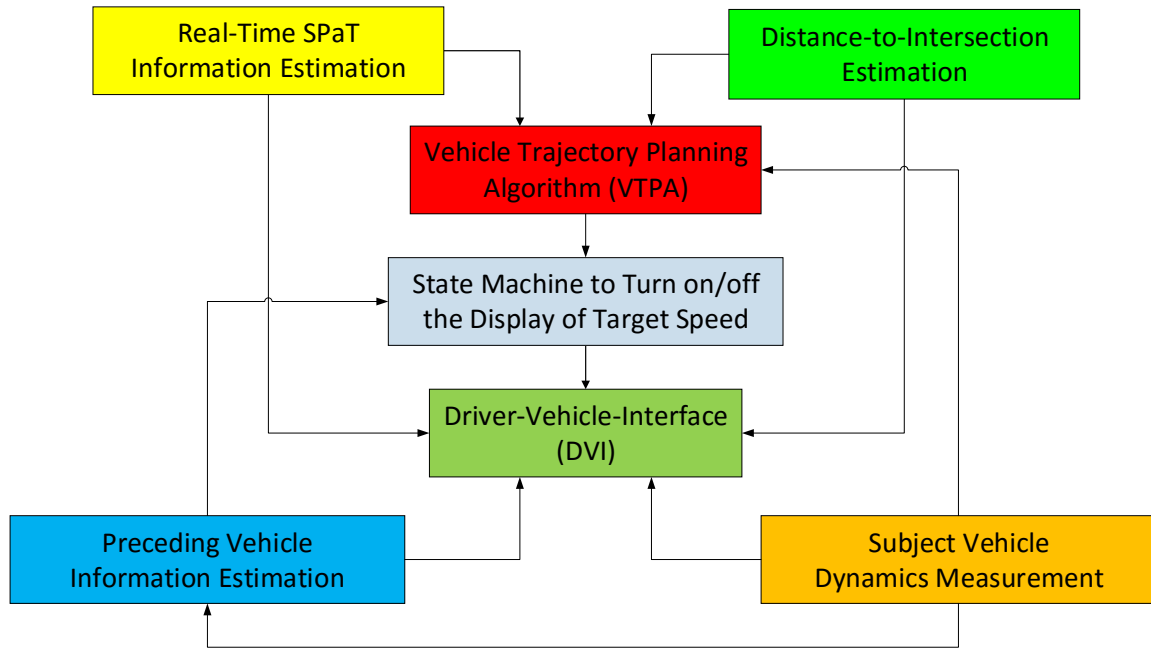
Fig. 3.9 The block diagram of the CAEHV and CAEHV-C model

## 3.2 Approach II (UC Riverside)

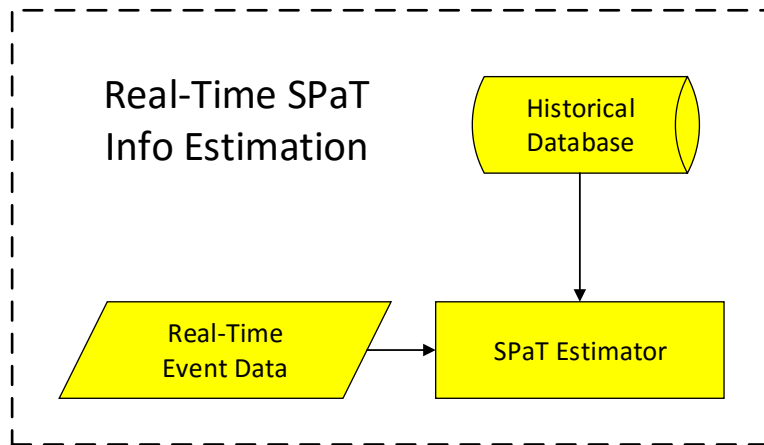
### 3.2.1 System Architecture

In this research, we developed a generic trajectory planning algorithm for the Eco-Approach and Departure (EAD) application that is compatible with actuated signals. As shown in Fig. 3.10, the system acquires information from four sources: SPaT from the signal controller, vehicle position from an on-board GPS receiver, vehicle dynamics from the vehicle's on-board diagnostics (OBD) port, and activity data of the preceding vehicle from a forward looking automotive radar (i.e., typical radar used for adaptive cruise control functionality). A vehicle trajectory planning algorithm takes this aforementioned information into account and determines an eco-friendly trajectory speed profile in response to the dynamic phase and timing information of the actuated signal. To

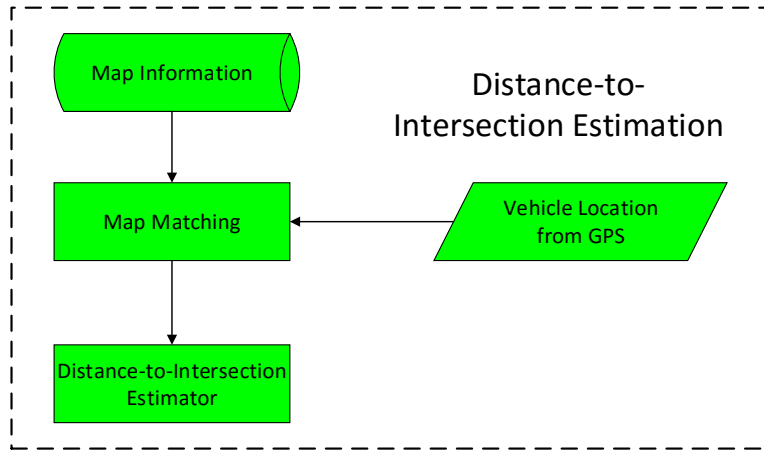
incorporate safety consideration in the EAD application design, a state machine has also been developed to switch the display of the recommended speed based on the headway from the preceding vehicle.



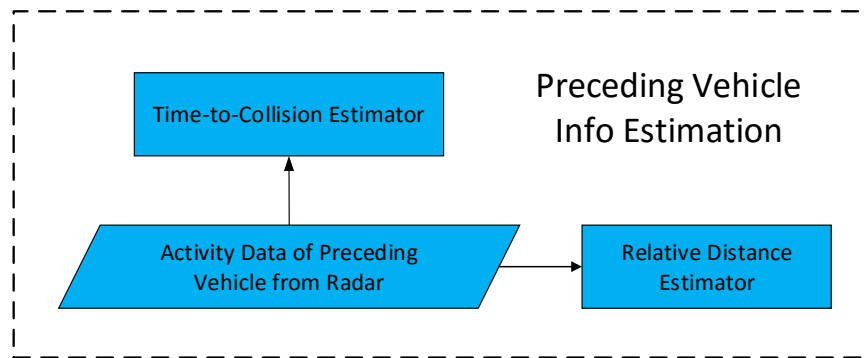
(a) EAD system architecture



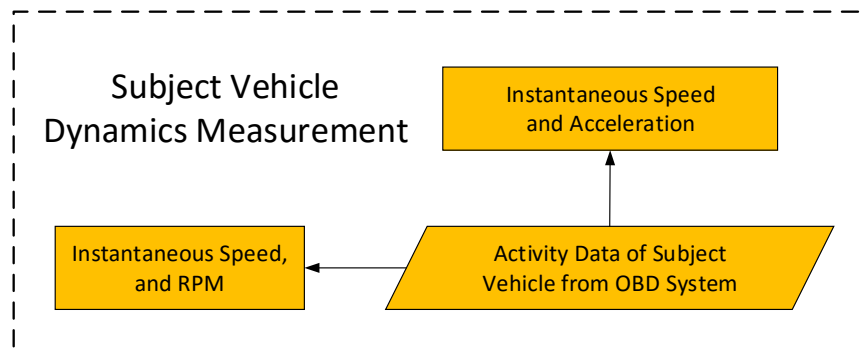
(b) Real-time SPaT Information estimation block



**(c) Distance-to-intersection estimation block**



**(d) Preceding vehicle information estimation block**



**(e) Subject vehicle dynamics measurement block**

**Fig. 3.10 Architecture and Components of the EAD VPT algorithm**

The primary objectives of the algorithm are to: 1) keep safe headway while not exceeding the speed limit and not crossing on red; 2) avoid or minimize idling at the intersection; and 3) avoid unnecessary acceleration and deceleration. The first objective is the basic requirement for safe driving. The second and third ones would help reduce energy and emissions. We discuss the vehicle trajectory planning algorithm in Sect. 3.2.2 and 3.2.3, and briefly introduce the radar system and state machine in Sect. 3.2.4.

### 3.2.2 Approaching During Green or Yellow Phase

For actuated traffic signals, if the vehicle approaches the intersection during the green phase, it will receive the estimated upper bound  $G_u$  and lower bound  $G_l$  of the remaining actual green time from the SPaT message. The upper bound and lower bound of the remaining effective green time (denoted as  $g_u$  and  $g_l$ , respectively) can be written as

$$\begin{aligned} g_u &= G_u + Y - t_b \\ g_l &= G_l + Y - t_b \end{aligned} \quad (14)$$

where  $Y$  is the yellow time and  $t_b$  is the buffer time to provide a safe transition between the yellow phase and red phase. In this research,  $Y$  is set to 4s and  $t_b$  is set to 1s so the remaining effective green time is computed by adding three seconds to the remaining actual green time shown in the SPaT message.

If the vehicle approaches the intersection during the yellow phase, the SPaT message provides upper bound  $Y_u$  and lower bound  $Y_l$  of the remaining yellow time ( $Y_u$  equals  $Y_l$  usually). The remaining effective green time for the vehicle is then

$$g_u = g_l = Y_u - t_b = Y_l - t_b \quad (15)$$

An enhanced vehicle trajectory planning algorithm has been developed in this study based on the remaining green time information. As discussed in the previous section, it takes at least  $t_{min}$  to reach the stop line, where  $t_{min}$  is calculated based on the current speed of the vehicle and the distance from the stop line.

If the vehicle is close to the intersection (i.e.,  $d \leq d_s$ ), we use the following criteria to ensure that the vehicle never crosses the intersection on red: If the guaranteed remaining green time  $g_l$  is not long enough, i.e.  $g_l < t_{min}$ , the vehicle should decelerate in order to stop at the stop line. Otherwise, the vehicle should accelerate to the speed limit to pass through the intersection.

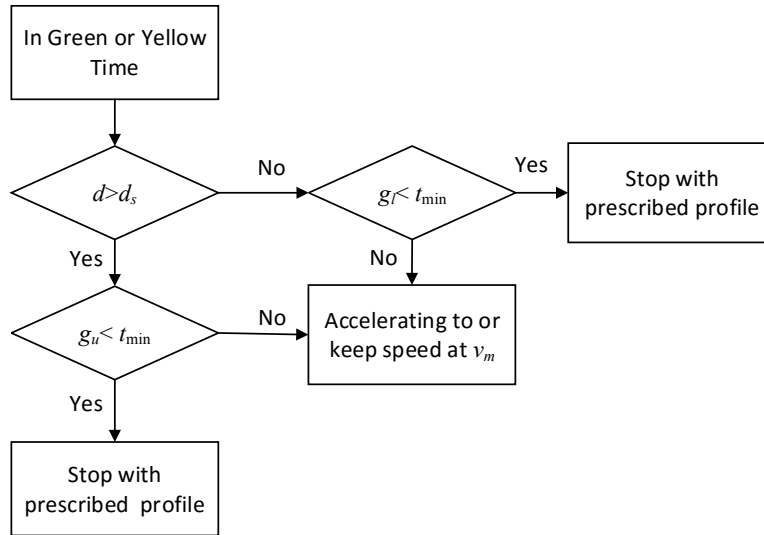


Fig. 3.11 Flowchart of eco-approach during green or yellow phase

If the vehicle is far from the intersection ( $d > d_s$ ) and it is possible to pass the stop line within the current green time, i.e.,  $g_u \geq t_{\min}$ , the vehicle will be advised to accelerate to the speed limit and pass the intersection before the signal turns red. Otherwise, the vehicle should gradually slow down to stop at the stop line with prescribed profile in [2].

Here, the threshold distance  $d_s$  is the minimum distance for a vehicle to make a safe stop from the current speed comfortably. It is computed using the deceleration profile model in [2], with a maximum deceleration rate of  $2.5 \text{ m/s}^2$  and a maximum jerk of  $10 \text{ m/s}^3$ . The algorithm for eco-approach during the green or yellow phase is summarized by the flow chart in Fig. 3.11.

### 3.2.3 Approaching During Red Phase

If the vehicle approaches the intersection during the red phase, the SPaT message from the signal controller will contain the estimated upper bound  $R_u$  and lower bound  $R_l$  of the remaining red time. The upper bound and lower bound of the remaining effective red time (denoted as  $r_u$  and  $r_l$ , respectively) can be simply derived by adding one second buffer time to  $R_u$  and  $R_l$ .

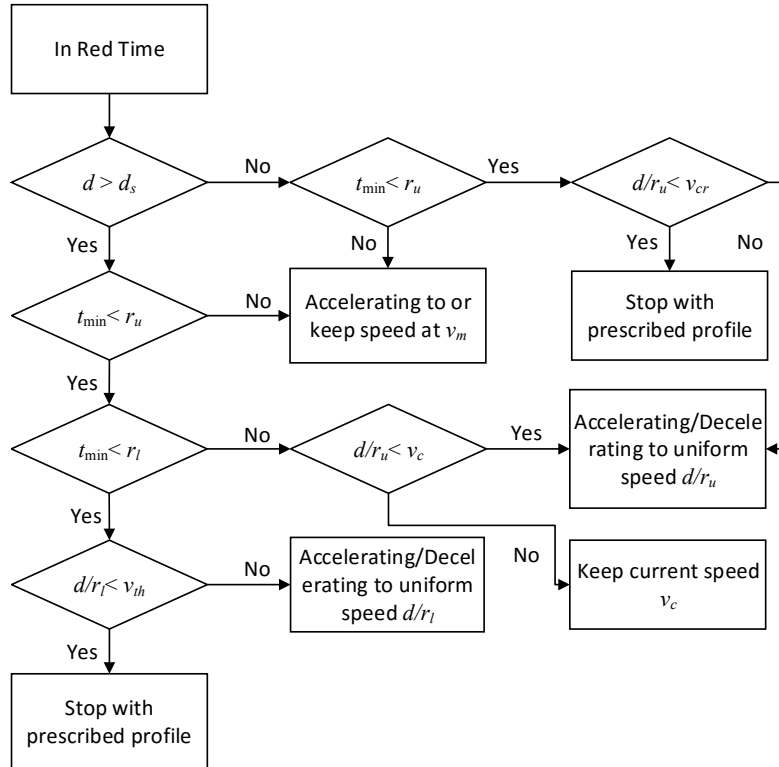
$$r_u = R_u + t_b, \quad r_l = R_l + t_b \quad (16)$$

In this case, the enhanced vehicle trajectory planning algorithm aims to provide an advisory trajectory that will allow the vehicle to pass the stop line immediately after the signal turns green, avoiding unnecessary acceleration/deceleration. As  $r_u$  is the remaining effective red time under the “worst” case, we use it to check safety and decide whether acceleration is needed. For other circumstances,  $r_l$  is taken as the key measure for trajectory planning.

If the vehicle is close to the intersection, i.e.,  $d \leq d_s$ , we use  $r_u$  for a conservative decision. If  $r_u \leq t_{\min}$ , the vehicle will be safe to reach the stop line at the speed limit. Otherwise, the driver has to keep the average speed below  $d/r_u$  to ensure that the vehicle never passes the intersection during the red phase. If  $d/r_u$  is lower than the crawling speed  $v_{cr}$  (say 5 mph), the vehicle will choose to stop at the stop line rather than keep crawling, as the energy consumption and emissions per mile are high at low speeds [51].

If the vehicle is far from the intersection, we first check if the current red phase is terminated before the vehicle arrives at the stop line with speed limit. If  $r_u \geq t_{\min}$ , the vehicle is free to speed up safely to meet the green phase at the stop line. If  $r_u < t_{\min} \leq r_l$ , the driver should accelerate to uniform speed  $d/r_u$  if the current speed  $v_c$  is below  $d/r_u$ , otherwise the vehicle should maintain its current speed. If  $r_l > t_{\min}$ , the target average speed of the vehicle should be  $d/r_l$ . Note that if  $d/r_l$  is lower than a threshold value  $v_{th}$  (say 20 mph), the vehicle will stop with prescribed profile instead of keeping low speed for a long distance for energy saving. The algorithm for eco-approach during the red phase is illustrated by the flow chart in Fig. 3.12.

The vehicle trajectory planner is updated every second based on the vehicle position, speed, and SPaT information. If any new decision is made, e.g. switching to another profile or changing the target speed, the advisory speed will be recalculated and displayed in real time.



**Fig. 3.12 Flow chart of eco-approach during red phase**

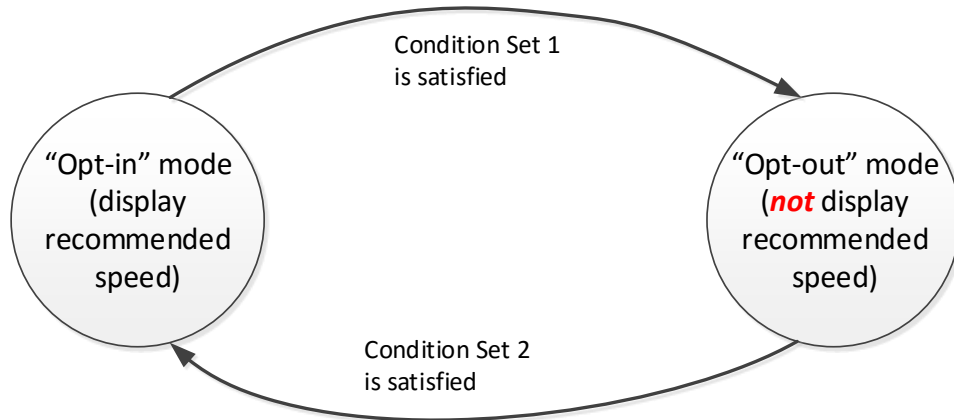
### 3.2.4 Safe Headway Detection Using Radar

Thus far, we have discussed the EAD algorithm to optimize the fuel consumption or emissions for a single vehicle without consideration of any surrounding traffic. If the subject vehicle is following another vehicle, the current algorithm's recommended speed may not be appropriate and can even distract the driver. Thus, we use a state machine to decide whether to display the recommended speed or not. A real-time automotive radar system is deployed to detect the following distance, speed, and deceleration of the preceding vehicle. In comparison with other aiding sensors such as camera and LiDAR (light detection and ranging), radar has some advantages due to its special radio frequency. Cameras rely heavily on the illumination condition of the environment, which makes it less effective under direct sunlight or at night. Compared with LiDAR, radar has much lower power consumption, with an affordable price for civilian use.

The activity data of the preceding vehicle is applied to estimate the headway from the preceding vehicle, simply by dividing the following distance by the vehicle speed. If the headway is lower than some predefined threshold or the vehicles' distance is too small, the display of recommended speed is turned off, and the driver is notified to keep a safe distance cautiously with his/her own judgment to avoid collision in case the preceding vehicle brakes abruptly. The specific criteria to turn on or turn off the state machine are shown in Fig. 3.13.

Condition Set 1 –  $A \cup B \cup C \cup D$

- A. Vehicle is out of the target corridor
- B. DSRC or GPS signal is lost
- C. Estimated time-to-collision (TTC) is less than  $T_2$  seconds
- D. Measured distance is less than  $d_1$  meters



Condition Set 2 --  $A \cap B \cap C \cap D$

- A. Vehicle is traveling along the target corridor with good DSRC and GPS signals
- B. Estimated time-to-collision (TTC) is greater than  $T_3$  seconds
- C. Measured distance is greater than  $d_2$  meters
- D. Last transition (from "opt-in") occurred more than  $T_1$  (e.g.,  $T_1=2$ ) seconds ago

**Fig. 3.13 State machine for dealing with preceding vehicles**



## 4 DVI Review and Designs

While there are infinite points of departure for any automotive DVI design, the purpose for developing an eco-driving DVI design during this project was to aid in prototyping, visualizing, testing, and demonstrating the underlying algorithms for providing an intersection eco-driving assistant. This project did not include formal human subjects testing or evaluations, although some insights, as described in later sections of this report, were noted by the project engineers during testing regarding the workings of the various DVI elements while testing the system performance.

Generally speaking, there are a number of DVI concepts that might ultimately be used to provide eco-driving information to the driver. In some high-end vehicles, an intersection eco-driving assistant might be integrated with a vehicle's navigation system, resulting in the eco-driving advice being displayed either on the dashboard or on a secondary display typically located in the vehicle's center stack. However, an intersection EAD assistant based on DSRC broadcast information does not necessarily require integration with an onboard navigation system because the DSRC broadcasts include both a local map and the signal phase and timing information. Thus, on some low-end vehicles the eco-driving information may only be integrated with the vehicle's dashboard. And finally, on existing vehicles, DSRC may become an aftermarket retrofit or add-on with a separate screen, HUD, or even a mobile phone interface.

Note that only visual information is considered in this project, and we haven't decided to introduce audio/vocal messages due to the controversy of distraction.

### 4.1 Analysis of Candidate DVI items

The objective of designing a DVI for the EAD assistant system is to provide drivers with "adequate" and "reliable" visual information through very few glances when approaching an intersection.

By *adequate*, we mean the driver is provided the right amount of information (as opposed to overloaded with too much information) that she/he can process/interpret information from each glance for deciding the driving actions to take within the next few seconds or the entire traveling course to the intersection, without needing to continuously look at or repeatedly glance at the screen.

By *reliable*, the information provided to drivers will lead to perceived wrong advice (e.g., the driver follow the advice to slow down for a smooth stop but finds that he/she can pass if driving at the original speed or to keep a specific speed profile but only to meet a stop), which leads to driver's distrust in the system.

The positive and negative effects of all possible DVI elements are analyzed as provided in Table 4.1.

**Table 4.1 Analysis of candidate DVI elements**

|   | <b>Pros</b>  | <b>Cons</b>   |
|---|--|---|
| <b>TIME information group</b>                     |  |   |
| Time to signal change                             | Similar to count down signal, that has been implemented elsewhere. People can correlate well among distance, speed and time to change. Does not require continuous glance. | Potential for speeding for catching signals. Only reliable for short lead time for actuated signals.  |
| Prediction time to pass (or stop)                 | Work similarly as time to signal but build in some cushions to avoid people speeding.  | It may potentially introduce higher uncertainties, making the advisory less dependable. Need time to understand.  |
| <b>SPEED suggestion group</b>                     |  |   |
| Instantaneous suggested speed                     | Information easy to be captured by driver. More appropriate for low speed automated intersection assist /cruise control  | Lack of the view of the future action. May require constant attention from the driver to follow a variable speed advisory.  |
| Suggested speed range                             | Information easy to be captured by driver. Relative easier for driver to follow as compared with instantaneous speed advisory.   | Also lack of the view of the future action. May require constant attention, though less than instantaneous speed advisory, from the driver to follow variable speed advisory. |
| Suggested speed difference (absolute or relative) | Suggested speed difference is easier for driver to capture. Including preview speed difference, with right look ahead distance may be better for driver to follow.         | If not designed right, it will also require significant driver's attention.   |
| <b>ACTION suggestion group</b>                    |  |   |
| Suggested speed trajectory                        | A linearized speed trajectory may be acceptable for driver to follow.  | A non-linearized speed profile is hard to capture by the driver in one glance.  |
| Coasting advice                                   | Coasting advisory does not require constant monitoring the display.  | Possibly annoyed by drivers in the following vehicles, causing unnecessary lane change.<br><br>This issue needs to be addressed for all cases where                           |

|  |  |  |
|--|--|--|
|  |  | advised speed is lower than common driving pattern.  |
| Suggested acceleration                         | This is very similar to speed differential. But if it is recommended as action, this is very difficult to capture.   | This should be rarely used for this purpose, unless the driver is constantly driving at a speed lower than speed limit.  |
| Suggested accelerator/brake pedal pressure     | Direct action advisory. No interpretation is needed. The effectiveness will depend on how long the control is needed and how steady is going to be and.  | It may require often 'feedback' observation to follow. Likely none of these actions will last long. Alternating actions is not preferable from all perspectives. |
| <b>Suggested action pattern and parameters</b> | Provides a snapshot of the total course of actions. The pattern may be of action categories rather than speed profile, i.e., cruise, coasting, decelerating, accelerating only when below speed limit. May need to have time point reminder for transition (dynamic) | Need to be designed for less engineering.  |

## 4.2 Discussion on DVI Issues

### 4.2.1 Traffic Signal State and Countdown

There are a number of different ways that have been used to depict the traffic signal state and countdown. Most projects have provided a simple text countdown in seconds next to a graphical depiction of the current state of the signal. The text countdown is one of the most direct means of providing this type of information. Drivers are already familiar with using a text-based countdown of the signal's time to change either directly, prominent in China, or indirectly, using the pedestrian countdown timers common in both the US and Europe. The eCoMove project also supplemented the text-based countdown timer with a pie chart timer as shown in Fig. 1.5. At the beginning of the green cycle, the chart was 100 percent green, and as the timer counted down, a counterclockwise sweep would turn the graphic red.

The problem with the traffic signal countdown timer is that it does not relate the traffic signal state with the arrival of the vehicle to the intersection. The driver must integrate the signal countdown information with his perception of speed and distance to the intersection to estimate whether or not the vehicle will arrive on green.

#### **4.2.2 Stopping Unavoidable Scenario**

If the driver is approaching the intersection at the end of a green signal cycle or the beginning of a red signal cycle, then the only alternative may be to bring the vehicle to a stop. The European eCoMove and ecoDriver projects included multiple eco-driving studies with intersection scenarios, but in each of those studies, the goal of the eco-driving assistant was only to instruct the driver to begin coasting to a stop sooner. The types of information that these eco-driving assistants displayed to the driver in this scenario included the following:

- V2I (Vehicle-to-Infrastructure) communication icon
- Traffic signal transition (from green to red) countdown
- Coasting icon (indicating that the driver should start coasting)
- Distance to intersection (either a numeric value or a vertical countdown bar)
- Predicted fuel savings if the driver begins to coast now (percentage)
- Feedback once the driver began correctly coasting to a stop (a confirmation icon)
- Feedback in the event of an abrupt deceleration

The reviewed eco-driving DVIs already captured the most critical information that would be required to instruct a driver on when to begin coasting to a stop. The only additional information that a driver may find to be useful would be an overall scenario preview. However, providing this type of information would need to be both vehicle dependent, because the coasting profiles vary from vehicle to vehicle, and traffic dependent, because the algorithm needs to know the queue length ahead in order to accurately predict when to start braking.

#### **4.2.3 Maintaining a Target Speed to Clear the Intersection Scenario**

If the driver is approaching the intersection at the end of a red signal cycle or the beginning of a green signal cycle, then it is possible to provide the driver with a reasonable target speed (or target speed band) that, if followed, will allow the driver to clear the intersection without stopping. A similar concept, also known as the “green wave”, has already been implemented in some European cities to suggest a travel speed that will allow vehicles to clear multiple intersections on the green cycle.

Multiple previous studies provided drivers with discrete target speeds based on an upcoming change in the speed limit or a recommended speed for a future curve. Additionally, an earlier phase of this project created a similar DVI concept where a continuous green band on the speedometer was used to indicate the current recommended speed to achieve optimal fuel efficiency during the intersection approach (shown in Fig. 4.1). The types of information that these eco-driving assistants displayed to the driver in this scenario included the following:

- Target speed provided numerically (in the case of a speed limit)
- Target speed provided as an analog band on the speedometer (typically a green band)
- An icon depicting the reason for the speed change (speed limit or curve ahead)

The major problem with providing the driver with a continuously changing target speed profile, as was done in one of the displays tested in the eCoMove, is that this type of display sets up a visually demanding one-dimensional tracking task for the driver. The driver must continually check the speedometer to make sure that the speedometer needle is within the continually changing suggested speed band. Furthermore, if the intersection approach profile was more than 12 seconds long and the speed profile required multiple glances, then this type of display would probably be considered potentially distracting under the NHTSA visual-manual guidelines. A less visually demanding design would provide the driver with a discrete final target speed (or target speed band), and then simply provide feedback if the driver exceeds an eco-friendly acceleration rate. Use of an icon along the lines of the Dutch green wave icon might also be useful to provide the driver with context as to why the eco-driving assistant is suggesting that speed.

Additionally, if the driver is unable or unwilling to follow the suggested speed advice, then the eco-driving assistant will need to recalculate the predicted outcome of the scenario based on the actual driving behavior. While such recalculations are to be expected, careful thought must be given to the allowed transitions to prevent overwhelming the driver with seemingly contradictory or unobtainable advice. If the current intersection approach falls on the border between two different predicted outcomes, the transition must be managed so that the system's advice doesn't quickly alternate between speed up or slow down. Similarly, if the suggested speed is greater than the current traffic flow, the system might continue to raise the suggested speed, even though the driver was clearly unable to comply with the original lower suggested speed.

#### **4.2.4 Decelerate to a Lower Speed to Avoid a Stop Scenario**

Perhaps the most challenging intersection approach, from a behavioral standpoint, occurs when the driver is approaching the intersection in the middle of a red cycle. In this case, giving the driver advice to start coasting can still result in the vehicle being required to stop. Modern vehicles are extremely efficient at coasting, especially in the lower speed bands from 25 to 35 mph (35 to 50 km/h). Based on tests with the PATH 2008 Nissan Altima, on a flat surface, decelerating from 25 mph to 18 mph, by coasting alone, took almost 15 seconds and covering a distance of almost 145 m, which could be almost half the distance between intersections in an urban environment.

The major DVI challenge in conveying this unconventional speed profile to the driver lies in communicating the intended speed profile with sufficient preview and justification to convince the driver to follow the profile. In a dense urban environment, the best solution might be to calculate and communicate the slower speed to the driver before the driver begins accelerating from the previous traffic signal. However, in many cases the vehicle may already be traveling at speed, and convincing the driver to significantly slow long before reaching the intersection will be a challenge. The types of information that an eco-driving assistant might display to the driver in this scenario included the following:

- Target speed provided as a numerical value or speed band on the speedometer
- Traffic signal state and countdown to the next signal change
- Distance to intersection

- Graphical preview of the approach scenario describing the intended outcome (if you follow these instructions, then you will catch the green cycle)
- Graphical preview of the approach instructions (when to brake, coast, or maintain speed)
- Icons depicting when to actively brake or coast

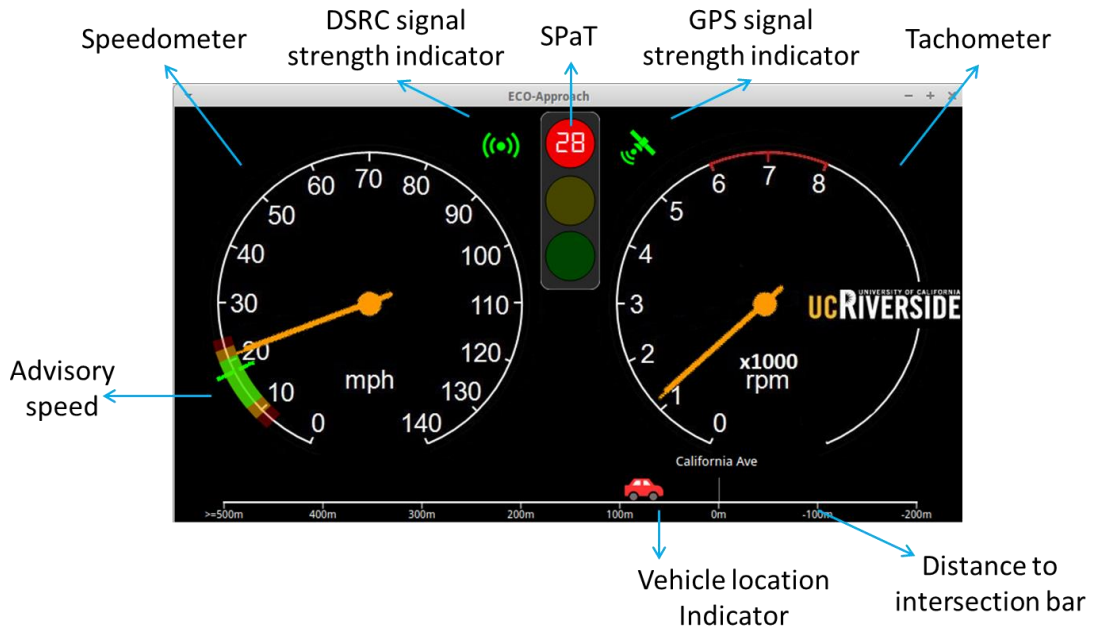
The human factors issues related to this scenario that might need testing are numerous given the unconventional speed profile that is being suggested. The main research question is whether or not the suggested display elements would provide enough information to the driver to understand that if they follow the advice, they will catch the green light without stopping. The key to convincing drivers that they should follow the proposed unconventional intersection approach lies in convincing the drivers that they will benefit by catching the green light without stopping.

### 4.3 DVI Design I (UC Riverside)

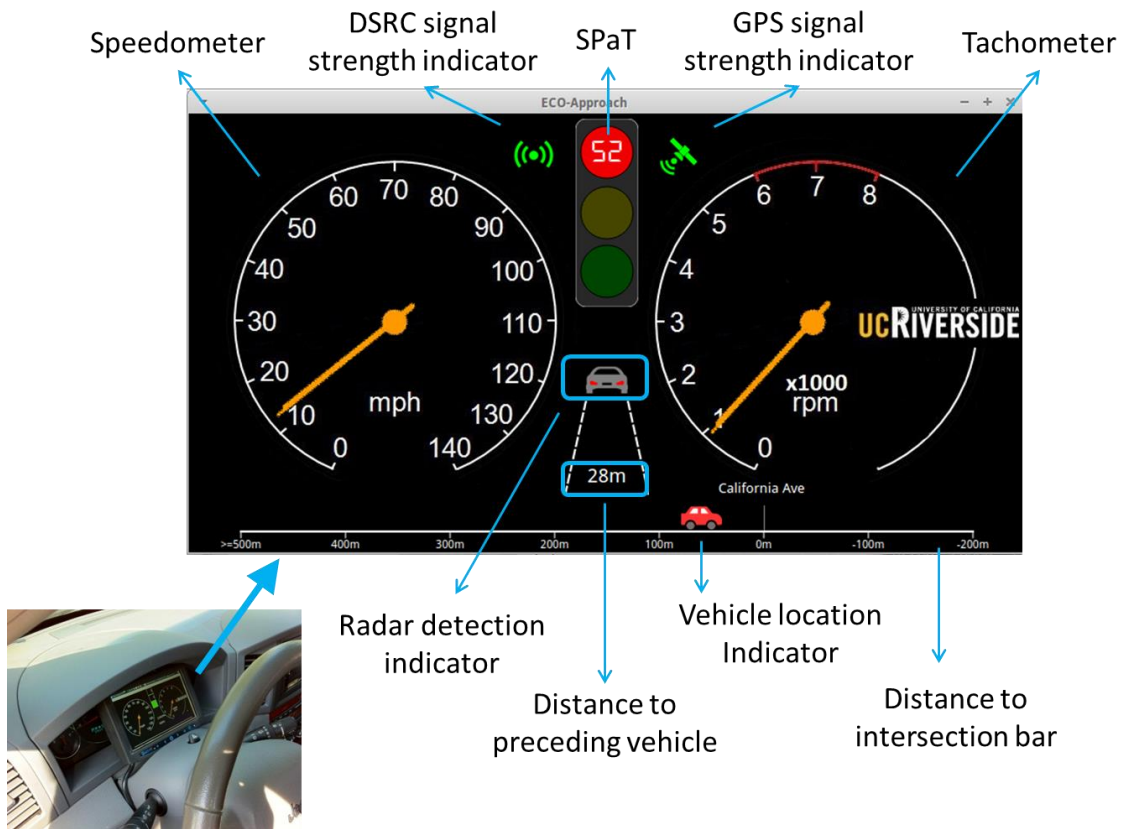
For the artificial dashboard, the UC Riverside team proposed a graphic user interface (GUI) that presents a number of items to the driver for test and development purposes (see Fig. 4.1). As shown in the figure, the following were displayed:

- 1) the vehicle's current speed (i.e., speedometer);
- 2) the vehicle's RPM;
- 3) an "advisory" speed as calculated from the velocity planning algorithm, along with a green-zone, yellow-zone, and red-zone that moved along the edge of the speedometer;
- 4) the SPaT countdown information for the current signal phase;
- 5) signal strength indicators for DSRC and GPS, respectively;
- 6) radar detection indicator (i.e., indicating if a vehicle was within the radar detection range);
- 7) distance to the preceding car within the radar detection range (in meter);
- 8) distance to the intersection (in meter);
- 9) vehicle and intersection location indicators. Please note again, that this GUI was developed primarily for testing purposes, not for final commercial deployment.

Fig. 4.1(a) shows the case when there is no preceding vehicle nearby. The target speed estimated from the trajectory planning algorithm is then displayed at the speedometer. Fig. 4.1 (b) shows the case when radar detects a preceding vehicle which is 28m in front. The display of target speed is then turned off in this condition to avoid any distraction.



(a) Target speed displayed, no preceding vehicle



(b) With preceding vehicle, target speed not displayed

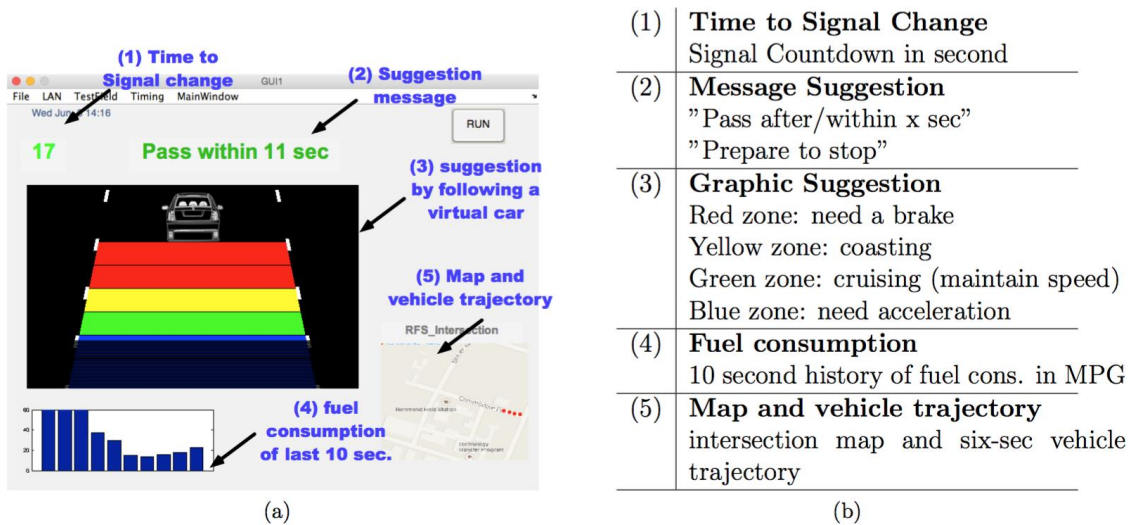
Fig. 4.1 Artificial dashboard for field testing (Design of UC Riverside).

#### 4.4 DVI Design II: Virtual Preceding Car (UC Berkeley)

This design was originated from the concept of Virtual Preceding Car that introduces a pilot eco-driving vehicle that can be seen as the desirable future of the host vehicle. Moreover, all interface displays under different scenarios are consistently merged into a graphic recommendation of keeping a moderate distance (advisory headway) from the preceding car. The principles of this design rely on the following considerations:

- The car following is the most conventional behavior that drivers are familiar with and easy to understand, rather than realizing a certain value of speed or acceleration.
- The changing of distance is much smoother than the changing of (advisory) speed and acceleration based on the integral characteristics of distance, which can relieve the inevitable occurrence of advisory value jumps accompanied by displayed message jumping back and forth.
- No hard decisions on scenarios will be put forward, which can decrease the occurrence of recommendation jumps caused by potential scenario transitions during an approach to an intersection.

The display items of the VPC design are explained as in Fig. 4.2 below.



**Fig. 4.2 DVI description of the Virtual Preceding Car (VPC) design**

Actually, the text suggestion and the graphic suggestions have different meanings. The graphic message illuminates the advisory action for the driver by a headway with one highlight color zone indicating the distance of headway, while the text message presents the whole prediction about this approaching trip. Since there are several scenarios corresponding to different recommendations, the two kinds of messages can be fused into a comprehensive understanding of the entire recommendation trajectory.

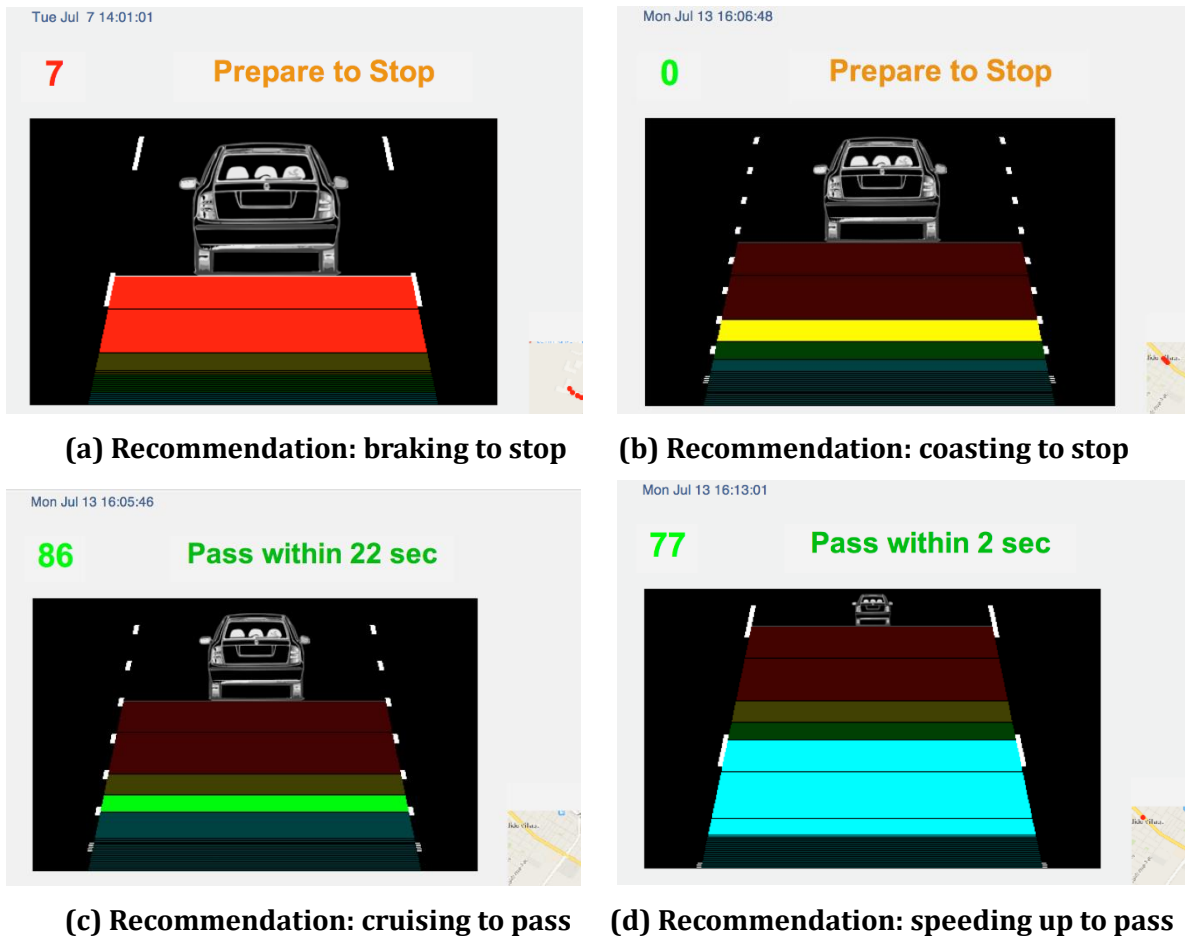
**Table 4.2 Recommendation messages and their corresponding scenarios (VPC design)**

| Scenario            | Graphic Message | Text Message       |
|---------------------|-----------------|--------------------|
| I1 (Maintain speed) | Green Zone      | Pass within x sec. |



|                        |                      |                    |
|------------------------|----------------------|--------------------|
| I2 (Speed up to pass)  | Blue Zone            | Pass within x sec. |
| I3 (Unavoidable stop)  | Yellow Zone          | Prepare to stop    |
| I4 (Unavoidable stop)  | Yellow or Red Zone   | Prepare to stop    |
| I5 (Slow down to pass) | Yellow or Green Zone | Pass after x sec.  |
| I6 (Maintain speed)    | Green Zone           | Pass after x sec.  |

The snapshot displays in Fig. 4.3 stand for the different scenarios, from which these interface items can be illustrated more directly. The subfigure (a) represents the driver was warned to *prepare to stop* at the middle of the red phase; The subfigure (b) represents the driver was warned to *prepare to stop* at the end of the green phase; The subfigure (c) represents the driver was suggested to *maintain speed to pass*; The subfigure (d) represents the driver was suggested to *speed up to pass*.

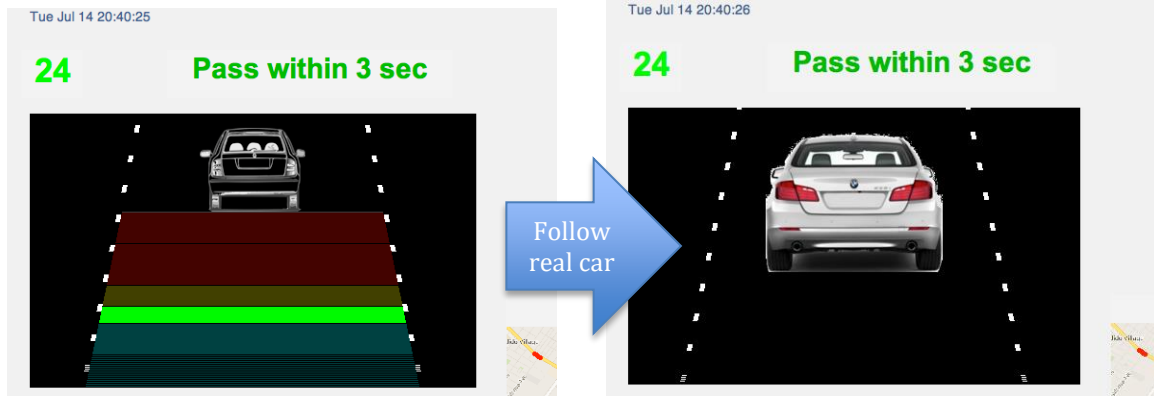


**Fig. 4.3 DVI Messages for different scenarios (VPC design)**

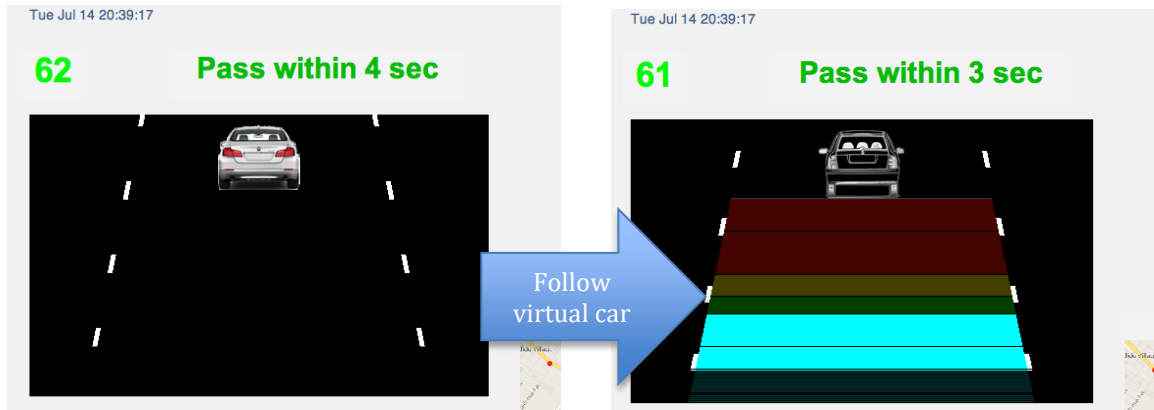
Moreover, another advantage of the VGC design is easy to deal with real preceding cars in real traffic. Once a real frontal vehicle is detected by radar on board, whether it will influence the eco-driving recommendation and interface can be easily determined by the position relation between the real and virtual vehicles. If the real vehicle is in front of the virtual vehicle, the driver is suggested to follow the displayed system recommendations,

otherwise the driver is suggested to follow the real preceding vehicle and ignore all the advisory information. In contrast to the approaches of considering the preceding vehicle in the planning algorithms, the VPC design involves the interaction with the preceding car in a natural way, which can be seen as a kind of *interface processing* rather than the conventional algorithm processing.

The switches between virtual and real car following are illustrated in Fig. 4.4.



(a) When the real preceding vehicle is behind the virtual one



(b) When the real preceding vehicle is in front of the virtual one

Fig. 4.4 DVI design dealing with a preceding vehicle (VPC design)

However, there are still several arguments requiring further consideration on the application of the VPC design. First, car following is still a driver's behavior that needs continuous attention, which will be an obstacle for the driver assistant system due to potentially significant driver's distraction. Second, the graphic colors including red, green and yellow would possibly conflict to the visible signal in the real world, which somehow will make drivers confused.

#### 4.5 DVI Design III: Target Speed Information (UC Berkeley)

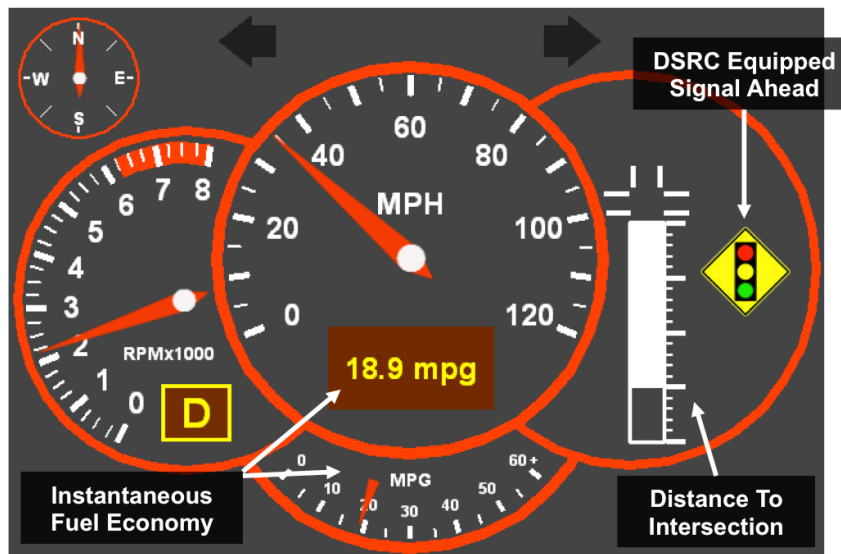
This design is named as *Target Speed Information* (TSI) because the main display item of recommendation is the desirable speed the system suggests the driver to reach no matter if it's higher, or lower than the current speed or getting to stop, which differs from the designs including advisory speed differential or brake/throttle actions. The design

principle was simply to base the stylistic look and feel of the DVI on the 2008 Nissan Altima test vehicle's current dashboard layout as depicted in Fig. 4.5. Many mid-end vehicles currently on the market contain LCD displays embedded within the dashboard, allow for either supplemental information to be displayed (such infotainment settings or navigation instructions) or completely reconfigurable dashboard displays.



**Fig. 4.5 Nissan Altima (2008) dashboard layout**

Although the DVI design mimicked the styling of the current test vehicle interface and was intended to be placed over the current dashboard of the test vehicle during testing, the design could not perfectly replicate the factory dashboard given the hardware and software constraints. The display was designed to fit on a lower resolution 7" LCD monitor, so for clarity, some display elements need to be enlarged, and non-essential information was not replicated. The idea behind the design was to utilize the right gauge cluster to provide eco driving information when approaching a DSRC-equipped intersection. An example of the screen when first approaching a DSRC-equipped intersection is shown below in Fig. 4.6.



**Fig. 4.6 Basic display layout (TSI design)**

As the vehicle first approaches the DSRC-equipped intersection and no eco-driving advice has been calculated, the right gauge cluster would switch to displaying the signalized intersection ahead of the icon. The white countdown represents the current distance to intersection, calculated based on the current GPS location and the received intersection's map message. This display would remain visible until either the vehicle passes through the intersection or the eco-driving assistant calculates specific advice for the driver based on one of the follow three scenarios described in the subsequent sections:

1. Accelerate to a target speed (or maintain speed) in order to pass through the intersection on green, which corresponds to T1/T2 and I1/I2/I6 (see Sect. 1.2.1).
2. Prepare to stop and start coasting because the signal is or will be red (or will still be red) by the time you reach the intersection, which corresponds to T3 and I3/I4.
3. Slow to a target speed below your current speed, so that you can pass through the intersection without stopping just after the signal turns green, which corresponds to T4 and I5.

The test vehicle already provides, as a configurable option, a text display of the instantaneous fuel economy located within the LCD panel of the speedometer. This configuration was repeated in the DVI created for the project, but a real-time fuel economy gauge was also added at the bottom of the screen. The vehicle compass direction (based on GPS) was also added, and both of these design elements were helpful during the system testing and debugging.

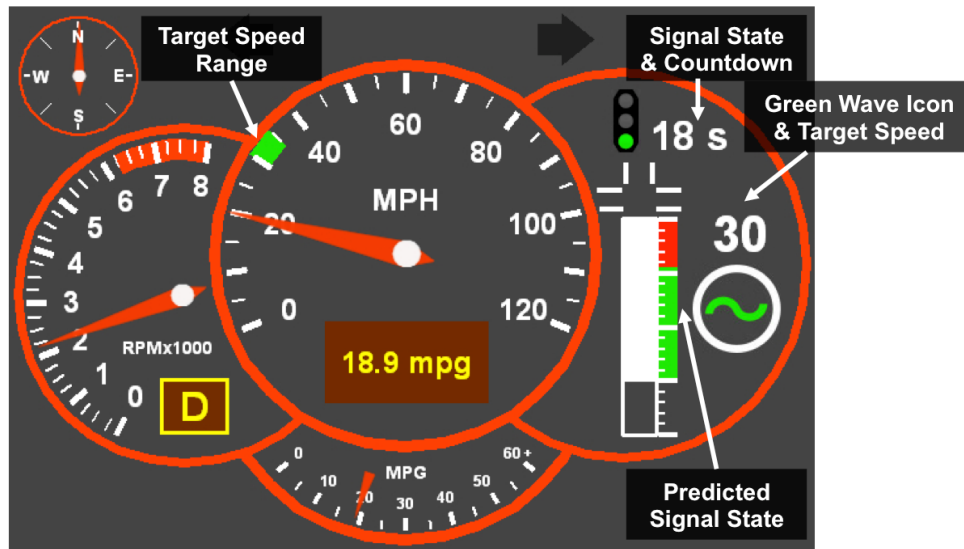
#### **4.5.1 Eco-Advice: Accelerate to a Target Speed**

One intersection eco-advice scenario is the situation where the vehicle is traveling slower than the speed limit, and will not pass through the intersection before the traffic signal will change to red. An example of this scenario and the corresponding eco-advice that would be shown on the display is depicted in Fig. 4.7. In this example, the vehicle is roughly 750 ft from the intersection traveling at 20 mph. Although the signal is currently green with 18 seconds remaining before changing to yellow and then red, continuing to travel at the vehicle's current speed will require roughly 26 seconds to clear the intersection and result in the driver needing to stop once the signal changes.

The intersection eco-driving display, depicted in the right gauge cluster, always includes the signal's current state and countdown timer, assuming that the signal's countdown information is known from the DSRC broadcast. Alongside the vehicle's distance to intersection countdown bar, the display also provides an estimation of the traffic signal state at the time the vehicle reaches the intersection. This is depicted by the green and green bars. As shown, at the vehicle's current speed, the traffic signal will remain green as the vehicle passes from 750ft to just under 225ft from the intersection. At that point, the traffic signal will change to red, and essentially, the driver will need to bring the vehicle to a stop. (The yellow phase of the traffic signal is essentially depicted as red for this display.)

However, if the driver can accelerate to at least 30 mph (assuming that the road has a speed limit of 35 mph in this example), then the vehicle would pass through the intersection in 17 seconds, before the traffic signal changes to red, and without needing to stop, thus, saving fuel. The eco-driving advice in this scenario is depicted by showing

the green wave icon, and suggesting the 30 mph target speed. The target speed is provided both as text above the green wave icon and as a green band on the speedometer. If the driver accelerates to the suggested speed, then the prediction of the signal state along the distance to intersection countdown bar will change to show that the light will be green when reaching the intersection. If the driver does not follow the eco-driving advice, then the eco-driving advice will eventually change to suggest that the driver begin coasting and prepare to stop.



**Fig. 4.7 Recommendation instructing to accelerate (TSI design)**

**4.5.2 Eco-Advice: Prepare to Stop and Begin Coasting**

When approaching an intersection either late in the traffic signal’s green cycle or early in its red cycle, the driver may have no choice but to slow down and come to a stop. These conditions may also occur when the driver was given earlier eco-advice intended to help her or him pass through the intersection on green, but failed to follow or was otherwise prevented from following that advice due to traffic conditions. In either case, once the intersection eco-driving assistant algorithm determines that the vehicle must stop, the DVI will show advice suggesting that the driver be prepared to stop and begin coasting in order to save fuel.

Fig. 4.8 depicts one example of this scenario. As shown, the vehicle is approximately 750 feet from the intersection traveling at 35 mph. On this trajectory, the vehicle will reach the intersection in roughly 15 seconds, but the traffic signal will remain red for at least 45 seconds more. Neither speeding up nor slowing down would particularly help in this situation, and the most fuel efficient course of action would be to start coasting. Thus, the intersection eco-driving advice displayed by the DVI displays includes a ‘be prepared to stop’ icon and a ‘coasting icon’. While there has been much research on providing different forms of feedback to try to get the driver to begin coasting earlier when approaching a stop sign, the main purpose of the DVI for this project was to demonstrate the underlying algorithms allowing these calculations to be made using DSRC broadcasts from

intersections. The coasting icon chosen was a simple variant of the types of coasting icons used in other eco-driving projects.

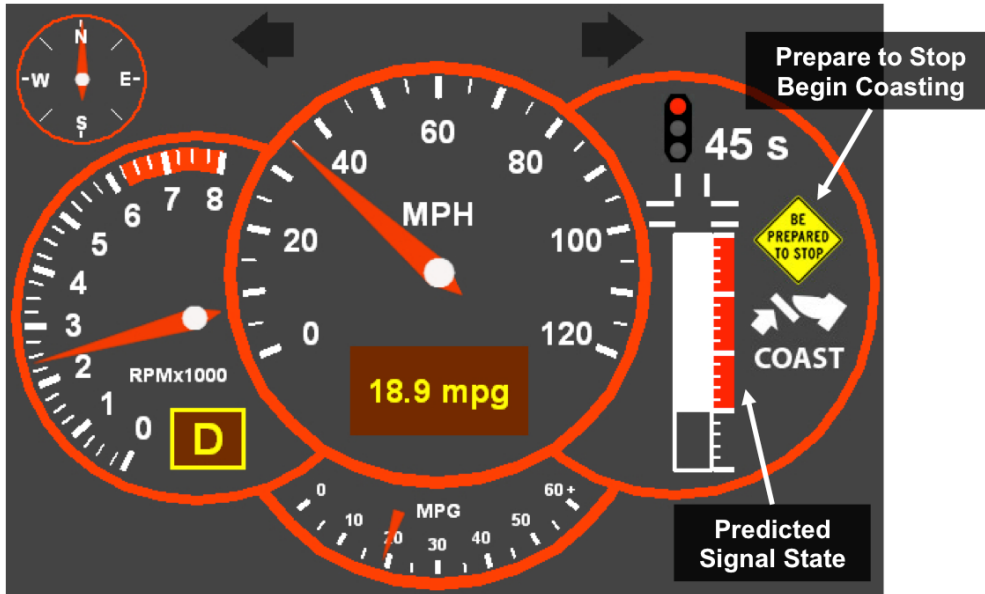


Fig. 4.8 Recommendation instructing to prepare to stop (TSI design)

#### 4.5.3 Slow to a Target Speed

When approaching an intersection in the middle of or at the end of the signal's red phase, it may be possible to slow the vehicle down by coasting up to the intersection, allowing the traffic signal time to change from red to green. On this new trajectory, the driver should be able to pass through the intersection without needing to bring the vehicle to a stop. The eco-driving advice shown on the DVI in this scenario is shown in Fig. 4.9.

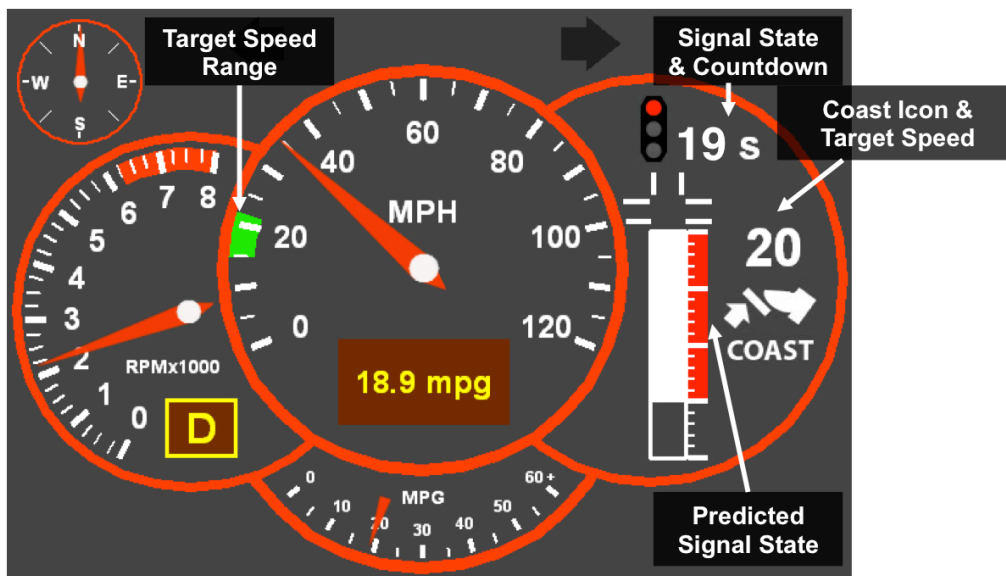
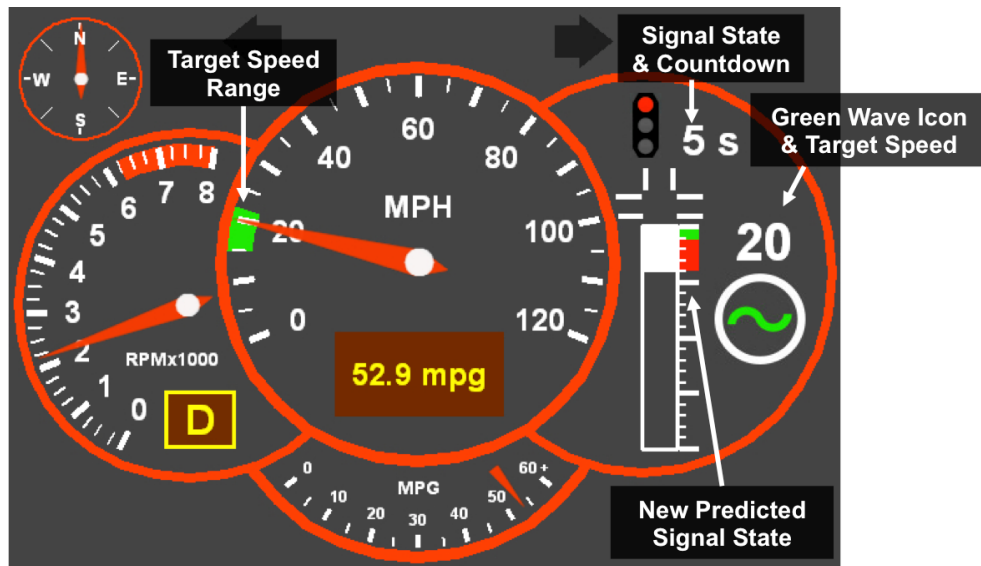


Fig. 4.9 Recommendation instructing to coast to a slower speed (TSI design)

In Fig. 4.10, the vehicle is depicted at 750 feet from the intersection approaching at 35 mph. On this trajectory, the vehicle will reach the intersection in roughly 15 seconds, but the traffic signal will remain red for 19 seconds, requiring the vehicle to stop at the intersection. However, if the driver were to slow the vehicle by coasting down to 20 mph, assuming a deceleration of 0.05 g which should be achievable with no more than a quick brake tap, then the vehicle should be able to arrive at the intersection shortly after the traffic signal turns green. If the driver follows the advice and coasts down to 20 mph, then the DVI will change to the screen depicted in Fig. 4.10.



**Fig. 4.10 Recommendation confirming the signal will turn green before arrival (TSI design)**

Once the driver reaches 20 mph by coasting, approximately 14 seconds should have passed, and the vehicle will now be approximately 200 feet from the intersection with a time to intersection of 7 seconds. As shown by the DVI, the new signal state prediction now indicates that the light should turn green before the vehicle arrives, and the driver should maintain 20 mph to catch the green light. As mentioned in a previous section, there are a number of human factors issues with the scenario that should be formally tested before trying to deploy this type of eco-driving advice. For example, the scenario depicted in this section assumed about a 2-second buffer between the light changing to green and the vehicle arriving to the intersection at 20 mph. Whether drivers will be comfortable approaching the intersection at any speed with such a short buffer is an open question that will probably depend on sight lines, lead traffic, and the suggested approach speed. It is also an open question as to just how soon drivers will be comfortable slowing when approaching an intersection. If the suggested eco-driving advice hinders the throughput of the previous intersection, drivers may not be comfortable following the advice because the traffic behind, who are not getting the eco-driving advice, will probably get impatient and aggressive towards how slow the eco-driver is going.

## 5 Testing Results

### 5.1 Field Testing Conducted By PATH

#### 5.1.1 Fuel Saving Metrics

##### Relative Fuel Consumption

The beneficial performance of eco-driving systems and methods are normally obtained based on the comparisons of fuel consumption before and after the host vehicle provided the advisory interface to drivers. As is well-known, the before data is denoted as the Baseline. However, the rigorous data results require the unbiased test environments including

- the same test bed, routes and intersections for comparison,
- the similar test hours ensuring unbiased traffic conditions,
- the same signal timings of the trips for comparison, which are various and critical to determine the amount of fuel consumption,
- the same drivers ensuring unbiased driving habits no matter there is an eco-driving assistant system or not.

To fulfill these conditions in real traffic, a large number of tests have to be conducted to achieve statistical significance, which is difficult to achieve within this project. Instead of traversing all the test conditions, we introduced a relative parameter to measure the fuel saving performance of a single trip, which is defined as

$$\eta = \frac{\text{Real Fuel Cons.}}{\text{Ideal Fuel Cons. (planned)}}$$

which can be explained as how economic one trip is by comparing with the desirable fuel consumption when the driver follows the planned trajectory. The larger the  $\eta$  is, the worse the fuel saving performance is. Otherwise, the closer to 1 the  $\eta$  is, the more fuel saving is achieved.

According to the physical meaning and empirical data, the metric of  $\eta$  can eliminate the influence of not strictly equivalent signal timing and largely mitigate the influences of different intersections and drivers. For the negative perspective, this metric is still relevant to the specific planning trajectory algorithm where the ideal fuel consumption was calculated.

##### Scenario-Specified Fuel Saving Statistics



In contrast to the previous studies, our research summarized the fuel saving performances under different pre-defined scenarios instead of giving a general result without considering the significant differences between scenarios and conditions. Qualitative analysis and experimental data show that, the fuel saving mechanisms and achievable benefits of the six scenarios (Instantaneous Scenarios) are diverse, thus the research in classes help us understand and utilize these mechanisms. Then the fuel saving statistic under the  $j$ th scenario ( $I_j$ ) is given by

$$FS_{stat}^j = \frac{\frac{1}{N_j} \sum_{k=1}^{N_j} \eta_k^E}{\frac{1}{M_j} \sum_{k=1}^{M_j} \eta_k^B}$$

where  $\eta_k^B$  denotes the relative fuel consumption of the  $k$ th baseline trip, i.e., without the EAD assistant, and  $\eta_k^E$  denotes the relative fuel consumption of a trip with the EAD assistant, both under the  $j$ th scenario. Meanwhile,  $N_j$  and  $M_j$  are the trip number of with and without the EAD assistant respectively.

Moreover, this fuel saving statistic can be calculated for a certain DVI design by only adding  $\eta_k^E$  among the trips with that design of DVI into the summation, which can provide the comparisons of assistant effects between different DVI designs.

### Overall Fuel Saving Statistics

Furthermore, we use the driving experiments on the corridor test bed to statistically obtain the occurrence frequencies  $P_j (1 \leq j \leq 6)$  of all scenarios under the real traffic conditions. Therefore, combining with the results of classified fuel saving, the following statistical result can be calculated by

$$FS_{stat} = \sum_{j=1}^6 FS_{stat}^j * P_j$$

This result has taken the occurrence chance of each scenario into consideration, which is a stronger evidential measure to explain the average fuel saving performance that the EAD assistant can provide in real driving environments.

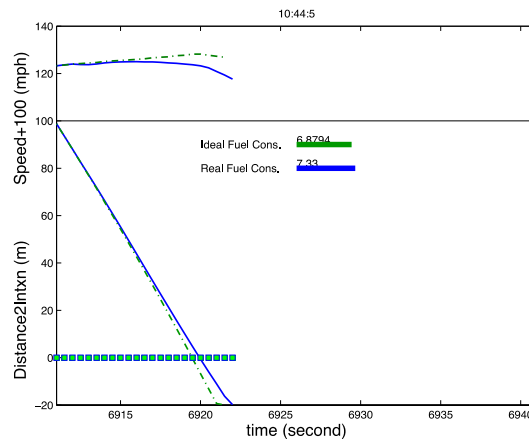
#### **5.1.2 Example Trips of Different Scenarios**

Two groups of trips along with their fuel consumption behaviors are illustrated below, one group contains nearly 100 rounds of driving at a single intersection at Richmond Field Station, and the other group contains 20 rounds of driving through ten successive intersections at the El Camino Real test bed.

For the first group, five drivers participated in the test and the driving environment is consistent for all drivers. Each driver had completed four sets of driving trips at the test track. Each set includes an individual approach with certain DVI display setups. Therefore, the comparisons can be made from the perspectives of both driving scenario and DVI design.

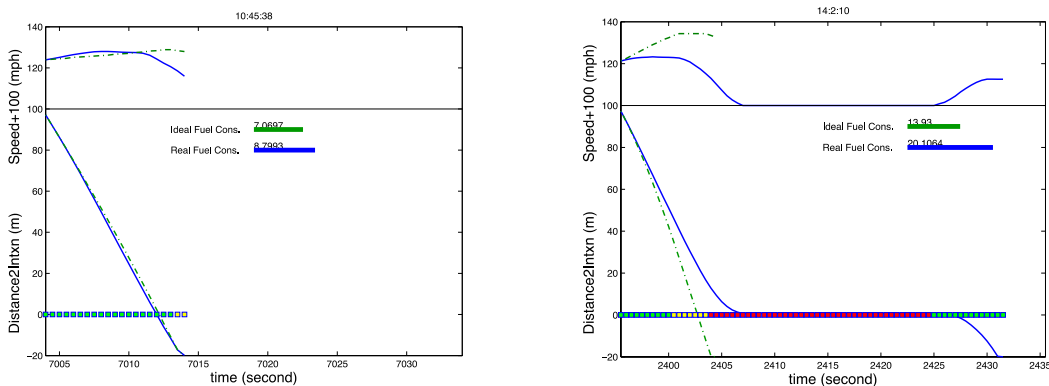
For the second group, four drivers participated to make round trips on the northbound and southbound of the El Camino Real corridor. The entire vehicle trajectories along with all the signal timing data were recorded for a comprehensive post-trip analysis. Since the difference of DVI designs were not planned to be investigated in this group of tests, only the DVI design of VPC was deployed.

For the figures in this section, the dashed green line stands for the planned trajectory and the solid blue line stands for the real driving trajectory. The signal phases along the time axis are also plotted for illustrating the entire scenario. The ideal and real fuel consumptions are drawn in numbers and length bars for direct comparison.



**Fig. 5.1 Sample trip of Scenario I1 (fuel consumption unit: gram)**

In the example trip of Fig. 5.1, the car had enough green time to pass the intersection. The advisory trajectory was maintaining and slightly increasing the speed. The driver followed the recommendation by the large and the  $\eta$  of this trip is around 1.066.

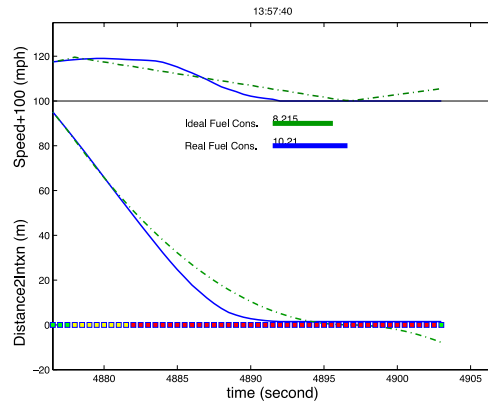


**Fig. 5.2 Sample trips of Scenario I2**

In the left example trip, the signal was about to change to yellow then red soon. The advisory trajectory was speeding up to pass and the driver largely followed the recommendation and the  $\eta$  is around 1.245.

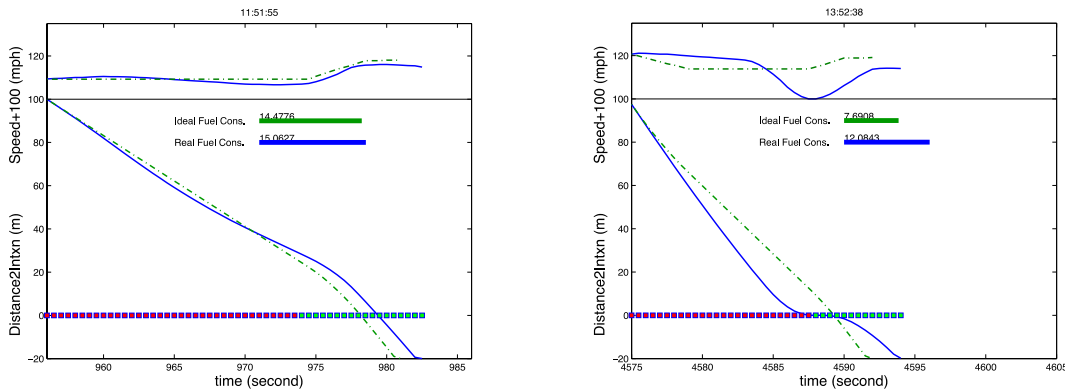
In the right example trip, the signal was also about to change to yellow then red soon. The advisory trajectory was speeding up to pass and the driver didn't follow the

recommendation then failed to pass before stopped by a red light. The  $\eta$  of this trip is around 1.443.



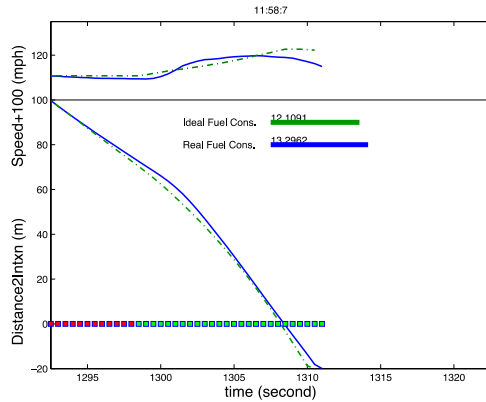
**Fig. 5.3 Sample trip of Scenario I3**

In this example trip, the remaining green is too short to allow a passing. The advisory trajectory was slowing down to an inevitable stop; the driver didn't reduce speed at the beginning and decelerated after the signal turned to red. The  $\eta$  of this trip is around 1.243.



**Fig. 5.4 Sample trips of Scenario I5**

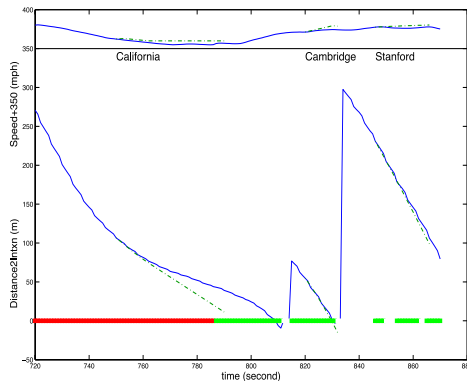
In the both example trips, the remaining red is too long for the driver to pass the intersection with a non-decreasing speed. The difference of the two advisory trajectories is that the left trip needed a significant deceleration due to a large initial speed while the right one only needed a slight speed reduction. In the left trip, the driver largely followed the planned trajectory resulting in a nonstop trip. The corresponding  $\eta$  is around 1.040. In the right trip, the driver reduced the speed but not enough, so had to make a short stop. The corresponding  $\eta$  is around 1.571.



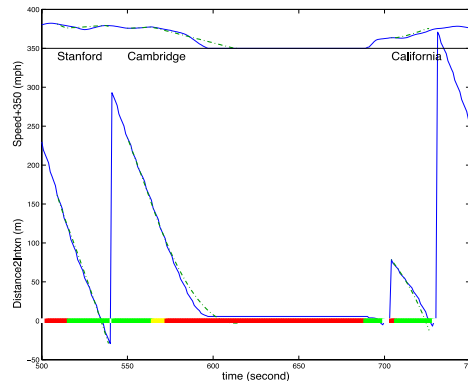
**Fig. 5.5 Sample trip of Scenario I6**

In this example trip, the remaining red was about to end and turn to green. Therefore, the advisory trajectory was maintaining speed to pass. In this scenario, the recommendation is somehow conflicted with the driver’s vision judgment, so the driver did not fully follow the system but slightly reduced the speed to accomplish the trip. The corresponding  $\eta$  is around 1.098.

The following figures present the example trips through successive intersections at the field test bed on El Camino Real.



**(a) Northbound trip**



**(b) Southbound trip**

**Fig. 5.6 Sample trips at successive intersections (El Camino Real)**

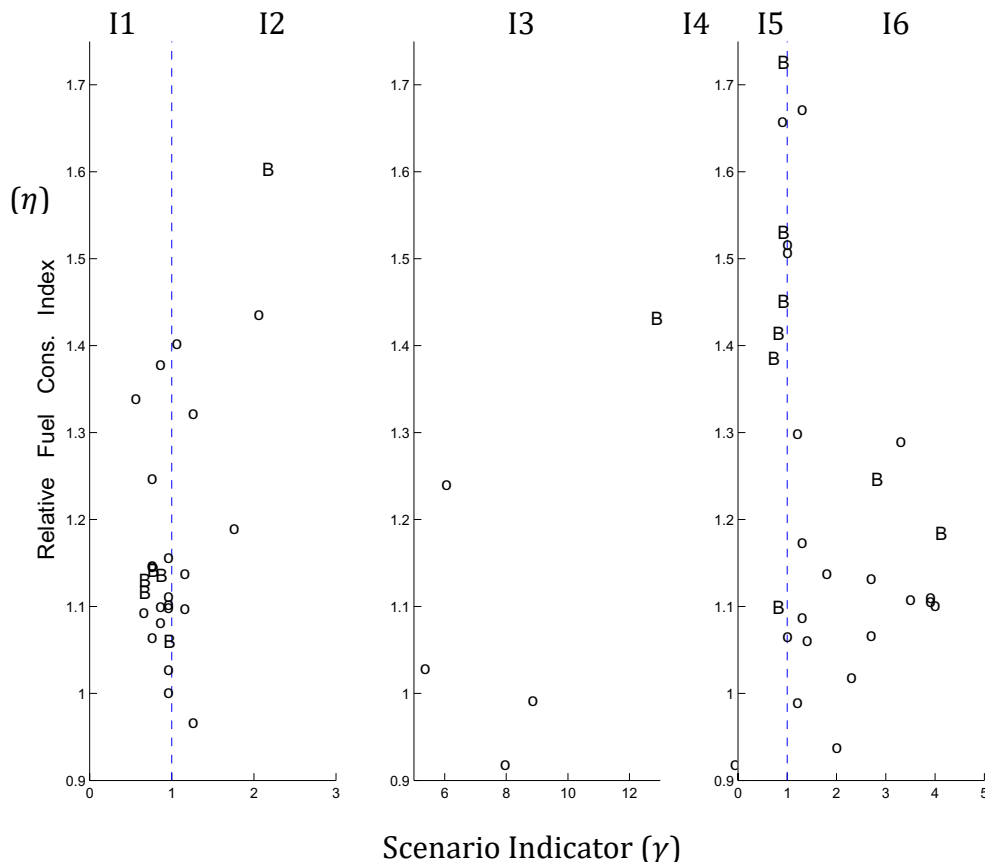
In trip (a) of Fig. 5.6, the EAD driving occurred when approaching the California Avenue. The scenario was I5 given the signal remaining time and the speed, so the recommendation was provided as reducing speed to avoid a stop. The real driving trajectory shows that the driver followed the recommendation. However, a higher speed might result in more fuel savings. For the other two intersections, the scenarios were I1 under which the driving trajectories were unsurprisingly very similar to the planned trajectories.

In trip (b) of Fig. 5.6, the EAD driving occurred when approaching the Cambridge Avenue. The scenario was first I3 then I4 due to the signal change, so the recommendation was displayed as preparing to stop. From the trips under this scenario, we can find that the driver (male) would not follow a planned trajectory to stop but follow his own habit, since

the accurate speed trajectory following is not easy to be realized in the proposed assistant system.

### 5.1.3 Statistical Results and Conclusions

By combining and processing the test results at Richmond Filed Station and El Camino Real, we obtained the comparisons of (relative) fuel consumption performances between before and after deploying the EAD assistant system, and tried to mining the principles of intersection eco-driving and the mechanism for how the EAD assistant system affects driver's behavior.



**Fig. 5.7 Relative fuel consumptions with respect to scenario indicator**

**“B”**: baseline, without EAD assistant; **“o”**: with EAD assistant

The comparison of relative fuel consumption ( $\eta$ ) between baseline trips ( $\eta_k^B$ ) and EAD-assistant trips ( $\eta_k^E$ ) are shown in Fig. 5.7. The symbol “B”s stand for the baseline trips, the circles stand for the EAD-assistant trips. There are several phenomena that could be observed from the different classified scenarios.

- No significant improvement under the scenario of “maintain speed to pass within green” (I1);
- Performance improved under the scenario of “speed up to pass within green” (I2) but fuel consumptions are still not economic ( $>1.3$ );

- Performance improved under the scenario of “have to stop” (I3/I4);
- Diverse performances under the scenario of “reduce speed to pass after red” (I5);
- Both significant improvement over baseline and fuel saving performance (<1.3) under the scenario of “maintain speed to pass after red” (I6).

Through the analysis of trip number data at different D2I (Distance to Intersection) points, evident transition regularities were found to explain how the EAD assistant system affects driver’s behavior, which is shown in Table 5.1 (a) and (b).

**Table 5.1 Scenario transition pattern and their fuel consumption performances**

| <b>(a) Trips without EAD assistant</b> |    |    |       |    |    |
|--|----|----|-------|----|----|
| # of each scenario                     | I1 | I2 | I3/I4 | I5 | I6 |
| 130m                                   | 5  | 1  | 3     | 6  | 0  |
| 90m                                    | 5  | 1  | 1     | 6  | 2  |
| 50m                                    | 7  | 0  | 3     | 5  | 0  |

| <b>(b) Trips with EAD assistant</b> |    |    |       |    |     |
|-------------------------------------|----|----|-------|----|-----|
| # of each scenario                  | I1 | I2 | I3/I4 | I5 | I6  |
| 130m                                | 7  | 14 | 8     | 19 | 7   |
| 90m                                 | 20 | 5  | 5     | 16 | 9   |
| 50m                                 | 31 | 2  | 8     | 12 | 2 * |

| <b>(c) Changes of Relative Fuel Consumption</b> |      |      |       |      |      |
|---|------|------|-------|------|------|
| Scenario #                                      | I1   | I2   | I3/I4 | I5   | I6   |
| Average $\eta$ without EAD assistant            | 1.11 | 1.51 | 1.43  | 1.45 | 1.24 |
| Average $\eta$ with EAD assistant               | 1.20 | 1.31 | 1.29  | 1.41 | 1.15 |

\*: Scenario I6 partially transitioned to I1

Combining the fuel saving performances (mainly see  $\eta$ , the smaller  $\eta$  is, the more beneficial the scenario is) and the above transition regularity, the kernel of the EAD assistant application can be presented as: **the mechanism of getting benefit from EAD recommendations is to guide driver to realize the transition from non-beneficial scenario (I2, I5) to beneficial scenario (I1, I6).**

Regarding the scenario-specified fuel saving statistics, the average together with the maximum improvement of the three DVI designs are presented in the Table 5.2. Summarized from these results, **the fuel saving performances varies from 0 to 22 percent for different scenarios; the three scenarios of “speed up to pass (during green)”, “have to stop (from green to red)” and “maintain speed to pass (from red to green)” can potentially make improvement by deploying the EAD assistant application.** From the viewpoint of newly introduced information by the assistant system,

under these three scenarios, the EAD information suggests that the driver to act differently from or against the normal behavior when he/she only catches the traffic signal by eyes. These contrasts of driving behavior, which are shown in Table 5.3 highlighted by green or red colors, have given a kind of explanation of how drivers benefit from the EAD assistant system. More interestingly, this conclusion is strongly supported by the fuel savings results (see the last row of Table 5.2).

**Table 5.2 Fuel cons. improvements for different scenarios and different DVI designs**

| Current signal state                               | Green                      | Green                | Green/Red           | Red                      | Red                        |
|--|----------------------------|----------------------|---------------------|--------------------------|----------------------------|
| Description of scenario $j$                        | I1: Maintain speed to pass | I2: Speed up to pass | I3/I4: Have to stop | I5: Reduce speed to pass | I6: Maintain speed to pass |
| Average baseline $\eta$                            | 1.11                       | 1.51                 | 1.43                | 1.45                     | 1.24                       |
| Design of "T2C"                                    | -16.3%                     | 0.2%                 | No data             | 11.6%                    | 10.6%                      |
| Design of "VEC"                                    | -1.7%                      | 4.4%                 | No data             | -6.3%                    | 4.3%                       |
| Design of "TGTS"                                   | -7.6%                      | 22.4%                | 9.7%                | No data                  | 5.1%                       |
| Maximum Fuel Saving ( $FS_{max}^j$ )               | -1.7% *                    | 22.4%                | 9.7%                | 11.6%                    | 10.6%                      |
| Average Fuel Saving among designs ( $FS_{avg}^j$ ) | -7.9% *                    | 13.4%                | 9.7%                | 2.7%                     | 7.1%                       |

\*: The negative improvements are possibly caused by driver's distraction or data deviation, which will be taken as zeros for further calculation.

**Table 5.3 Comparisons between driver's normal behavior and EAD recommendation**

| Scenarios                                      | I1             | I2           | I3                  | I4                  | I5  | I6                |
|--|----------------|--------------|---------------------|---------------------|---|-------------------|
| Timing of signal phase                         | Early green    | Middle green | Nearly end of green | Early red           | Middle red  | Nearly end of red |
| Normal behavior when knowing only signal phase | Maintain speed |              |                     | Gradually slow down |   |                   |
| EAD recommendation behavior                    | Maintain speed | Speed up     | Gradually slow down | Gradually slow down | Gradually slow down then accelerate when seeing green | Maintain speed    |

Meanwhile we present two conclusive inferences from this project. First, **the driving trend resulting in scenario transition plays a more critical role than the quantitative recommendation on speed or acceleration.** Second, **the achievable benefit of EAD**

**system cannot be simply concluded without considering the proportion and importance of all pre-defined scenarios.**

Following the second conclusion, the occurrence frequencies of all scenarios in real field tests are obtained from the trip data in the three round sets of driving-through-corridor, which are given in Table 5.4 below.

**Table 5.4 Occurrence probabilities of all the scenarios**

|                                |     |       |       |       |       |      |      |
|--------------------------------|-----|-------|-------|-------|-------|------|------|
| Current signal state           |     | Green | Green | Green | Red   | Red  | Red  |
| Scenario $j$                   | Any | I1    | I2    | I3    | I4    | I5   | I6   |
| Round number of Set 1          | 115 | 75    | 3     | 7     | 19    | 7    | 4    |
| Round number of Set 2          | 51  | 33    | 2     | 2     | 9     | 2    | 3    |
| Round number of Set 3          | 28  | 16    | 1     | 0     | 6     | 0    | 5    |
| Total number                   | 194 | 124   | 6     | 9     | 34    | 9    | 12   |
| Occurrence Frequency ( $P_j$ ) |     | 63.9% | 3.1%  | 4.6%  | 17.5% | 4.6% | 6.2% |

Taking all the above results into consideration, the **Statistical Average Fuel Saving** is derived as

$$FS_{avg} = \sum_{j=1}^6 FS_{avg}^j * P_j = 3.12\%$$

Meanwhile, the **Statistical Maximum Fuel Saving** indicates the economic performance can be possibly reached by an EAD assistant system, which is given by

$$FS_{max} = \sum_{j=1}^6 FS_{max}^j * P_j = 4.03\%$$

The results show that the real achieved benefit for the tests on the corridor test bed is not as significant as those presented in the previous studies (normally 10%~20%), which also means that the achievable benefit for multi-intersection corridor driving cannot be highly assessed or expected due to the consideration of the chance a vehicle can encounter the beneficial scenarios and conditions.

One of the main reasons for the insignificant improvement above is the fact that the coordinated traffic signals have been designed for efficient drive-through (such as green wave), which means the intersections are not independent, which results in a smaller chance of encountering EAD efficient scenarios.

#### **5.1.4 Preliminary Results of Human Factor Issues**

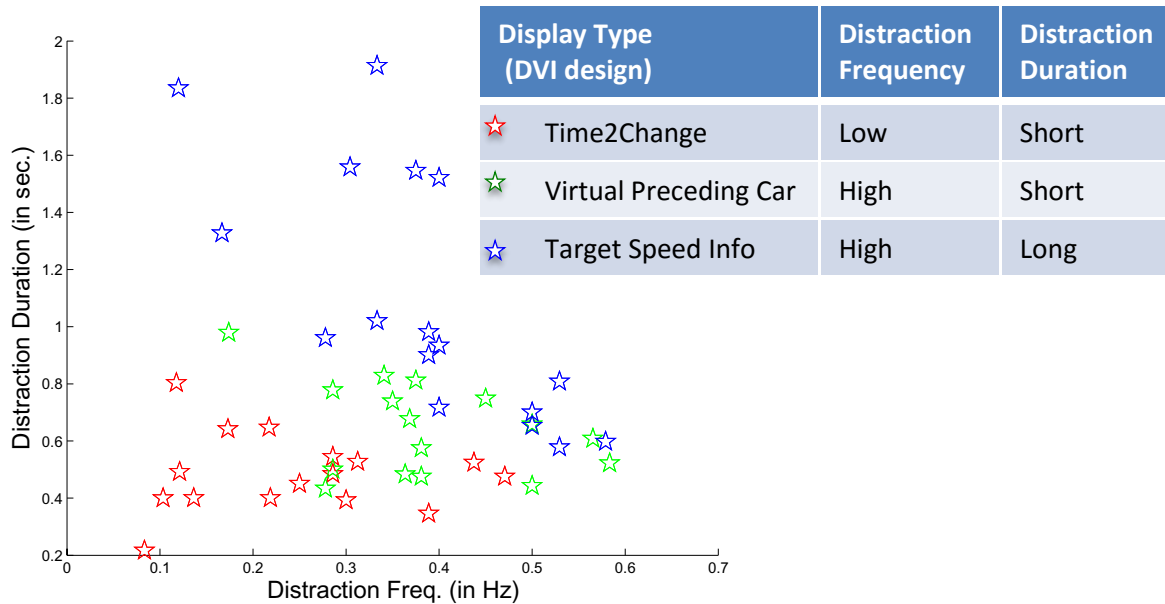
From the perspective of DVI design, the data presented in Table 5.2 show that **during the red phase, signal remaining time (Time to Change) information is more effective;**



**whereas during the green phase, speed recommendations can help to save more fuel.** However, it needs further study on factor relation and data support to verify this presumption into a conclusion.

According to the above discussion, the driver’s attention to the EAD interfaces deserves serious consideration because the influence of distractions to driving safety of these driver-assistant applications is always a big concern, especially when approaching an intersection. The basic requirement is to make design as easy as possible to understand and follow, which would result in driver’s minimum distraction from the perspectives of both (distraction) frequency and duration.

In this project, we have recorded the drivers’ face videos during their driving, from which the driver’s distraction measures were extracted. As plotted in Fig. 5.8, there are obvious differences of distraction measures between the different DVI designs. The “time to (signal) change” information is the simplest to understand and not relevant to the vehicle status, thus the corresponding distraction duration is short (<0.8s); the distraction frequency is also low (<1/3Hz) mainly because drivers have the natural ability to predict the following countdown once getting a number of signal remaining time. The other DVI designs, both VPC and TSI display, caused high distraction frequencies (>1/3Hz) according to the record video, which can be explained by the lack of continuity. However, regarding the distraction duration, the VPC design apparently requires shorter time than the TSI design, because the TSI messages are small in size and not straightforward enough as the VPC messages.



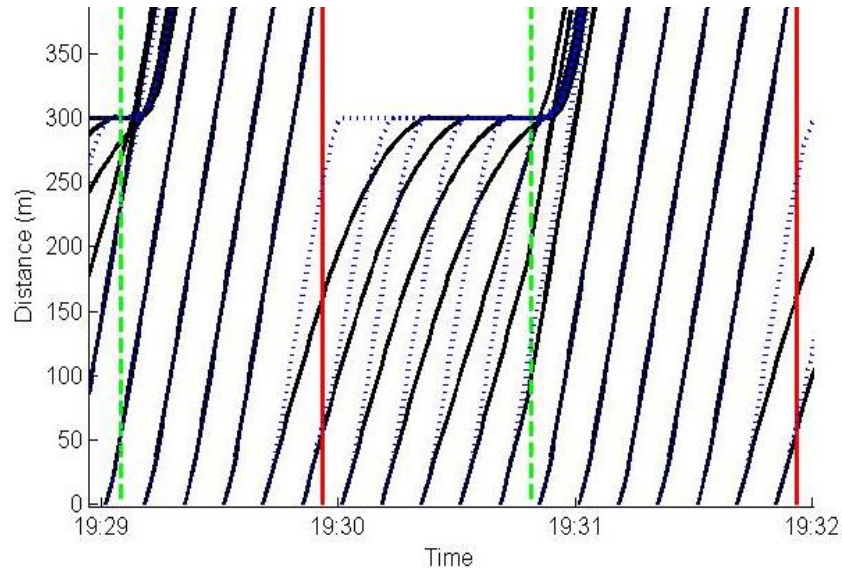
**Fig. 5.8 Drivers’ distraction durations and frequencies of the tests for three DVI designs**

Even though we present some analysis results of driver’s distraction here, the study is still too preliminary to depict the principles of how DVI designs and driver’s distraction are related. Therefore, further research recommendations are necessary and are given in Sect. 6.2.

## 5.2 Algorithm Validation or Evaluation Conducted by CE-CERT

### 5.2.1 Numerical Validation in Simulation

In this section, the proposed EAD algorithm was applied to simulate vehicle trajectories of a single passenger car at a hypothetical signalized intersection with different entry times. The SPaT information is from the field data collected at the El Camino Real connected vehicle test bed in the San Francisco Bay Area, California. As the range of DSRC transceivers in the current market is typically around 300 m (Ma et al., 2009), it is assumed that the SPaT information becomes available when the vehicle is 300 m from the intersection. The length of the study area is 400 m, from 300 m upstream of the intersection to 100 m downstream, which is fully covered by the DSRC signal. Road grade of the study area is assumed to be zero, and the speed limit is set to 40 mph. The time that the vehicle enters the study area varies from 7 a.m. to 9 p.m., with 10-second time intervals. Therefore, we are able to validate the proposed algorithm under different signal control plans that change by time of day. We also test multiple initial speeds from 20 mph to 40 mph.



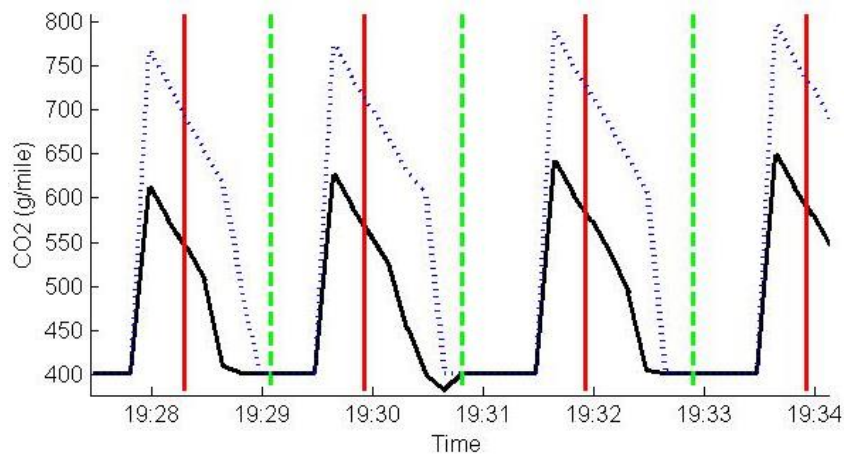
**Fig. 5.9 Simulated vehicle trajectories of informed and uninformed driving**

We also generate a set of uninformed (baseline) vehicle trajectories for comparison. We assume that the uninformed drivers attempt to cruise at or around the speed limit until they are very close to the intersection. Then, they may stop or not depending on the current traffic signal phase. In Fig. 5.9, we show the trajectories of informed driving with black solid curves, and uninformed driving with blue dotted curves during the time window between 19:29 and 19:32. We also use red solid vertical lines to represent the starts of red phases, and green dashed vertical lines to represent the starts of green phases. The initial speed is set to 25 mph. When the vehicle arrives during the green phase and passes the intersection without any delay, the trajectories of both uninformed and informed drivers are nearly the same. However, when the vehicle is delayed by the signal, the uninformed driver tends to make a sharp stop right before the intersection, while the informed driver may reduce the speed earlier to minimize the idling time. In case the vehicle arrives around

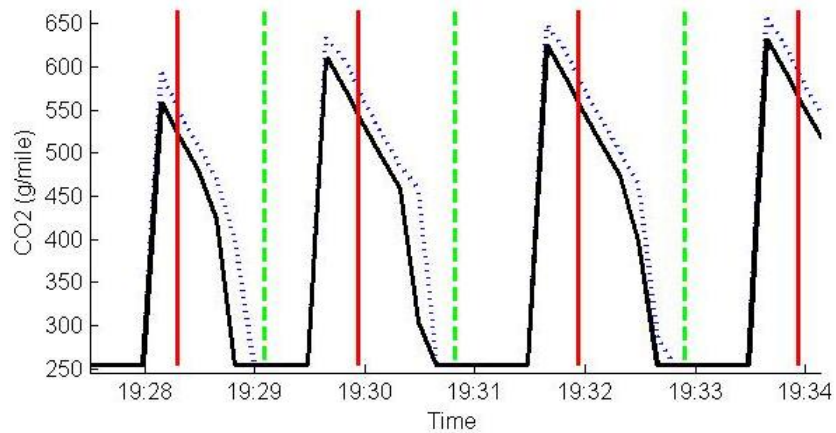
the end of the red phase, the informed driver may avoid coming to a full stop by wisely adjusting the speed so that the vehicle reaches the stop line right at the start of the green phase with a non-zero speed. As a result, this vehicle will depart the intersection earlier than a fully stopped vehicle as it bypasses the reaction time and start-up lost time after the signal turns green.

We apply the U.S. Environmental Protection Agency’s MOrtor Vehicle Emission Simulator (MOVES) model [53] to the simulated vehicle trajectories to estimate the associated energy consumption and emissions. MOVES uses Vehicle-Specific Power (VSP) as a primary metric in the estimation of vehicle fuel consumption and emissions. VSP is a function of speed, acceleration, mass, road grade, and vehicle-specific coefficients. The second-by-second vehicle trajectories are distributed into 23 operating mode bins according to their speed and VSP values. Then, we extract energy and emission rates of a typical passenger car from MOVES for each of the 23 operating mode bins. Finally, we apply the operating mode bin distribution to the energy and emission rates to compute the energy consumption and emissions of all the vehicle trajectories.

In Fig. 5.10, we compare the average CO<sub>2</sub> emissions of both uninformed and informed drivers with varying arrival times. The initial arrival speeds are 25 mph and 40 mph in Fig. 5.10(a) and Fig. 5.10(b), respectively. The results of the informed driver are shown with the black solid curves while those of the uninformed driver are represented by the blue dotted curves. As depicted in each figure, the two curves overlap each other when there is no delay. When there is delay, the informed driver outperforms the uninformed one as he/she avoids unnecessary acceleration and deceleration, especially when approaching the intersection with lower initial speed. As the uninformed driver tends to accelerate to the speed limit until they are close to the signal, it takes more effort to reach that speed if the initial speed is lower. This energy and emissions waste can be avoided if the SPaT information (even under actuated control) is available.



**(a) 25 mph as the initial speed**



(b) 40 mph as the initial speed

Fig. 5.10 Emissions of CO<sub>2</sub> per mile vs. arrival time

We analyze the mobility and environmental sustainability performance of the proposed EAD algorithm for actuated signals. Table 5.5 presents the simulation results of travel time, emissions of HC, CO, NO<sub>x</sub>, CO<sub>2</sub> and PM<sub>2.5</sub> per mile, and energy consumption per mile for different initial speeds. Generally, the travel time and emissions increase if the vehicle arrives with a low initial speed because it needs additional acceleration to pass the intersection. Note that the travel time stabilizes around 37.7 s for the initial speed higher than or equal to 30 mph. A possible explanation is that the vehicle arriving with low initial speed (say 30 mph) has a higher chance of saving the reaction time and start-up lost time from coming to a full stop. That compensates the extra time needed to pass the intersection.

In Table 5.6, we show the energy and emissions comparison results between the vehicles with and without the EAD application. As shown in the table, the differences in energy consumption and emissions will be significant if the initial speed is lower than or equal to 30 mph. The emissions of the EAD-equipped vehicle are 11%~30% less. As shown in (b), if the initial speed is around the speed limit, the reduction in emissions is not as much as in the low initial speed case. The differences range from 3.3% to 6.2%, depending on the type of pollutants. The average travel times of the EAD-equipped vehicle are also slightly better because some of these vehicles may be able to pass the intersection without stopping.

Table 5.5 Emission Performance of the proposed EAD algorithm

| Speed (mph) | Time (s) | HC (g) | CO (g) | NO <sub>x</sub> (g) | CO <sub>2</sub> (g) | Energy (KJ) | PM 2.5 (g) |
|-------------|----------|--------|--------|---------------------|---------------------|-------------|------------|
| 20          | 39.5     | 0.30   | 8.37   | 0.96                | 490                 | 6816        | 0.05       |
| 25          | 38.7     | 0.28   | 7.42   | 0.89                | 461                 | 6417        | 0.04       |
| 30          | 37.8     | 0.28   | 7.38   | 0.84                | 435                 | 6052        | 0.04       |
| 35          | 37.6     | 0.24   | 5.55   | 0.73                | 401                 | 5578        | 0.03       |
| 40          | 37.6     | 0.22   | 4.80   | 0.63                | 365                 | 5085        | 0.02       |

---

**Table 5.6 Energy and emission saving in percentage**

| Speed (mph) | Time  | HC   | CO   | NOx  | CO2  | Energy | PM 2.5 |
|-------------|-------|------|------|------|------|--------|--------|
| 20          | -0.03 | 13.6 | 19.9 | 20.5 | 10.8 | 10.8   | 25.8   |
| 25          | -0.03 | 13.9 | 20.4 | 21.1 | 12.0 | 12.0   | 26.3   |
| 30          | 0.27  | 14.1 | 22.2 | 19.6 | 11.2 | 11.2   | 29.6   |
| 35          | 0.73  | 7.6  | 12.5 | 13.7 | 7.6  | 7.6    | 18.2   |
| 40          | 0.40  | 2.7  | 5.0  | 6.1  | 3.3  | 3.3    | 6.2    |

### **5.2.2 Test on Different Scenarios in Riverside, California**

As shown in Fig. 5.11(a), the eco-approach and departure applications for actuated signals were tested on Palmyrita Ave, Riverside CA. The test vehicle approached the intersection (marked in Fig. 5.11(a)) from the east, proceeded through the intersection, and then completed the test run on the west side of the facility. The start of the intersection test zone was at 300 meters to the east of the intersection, and then end of the test zone was 100 meters to the west. The speed limit for the test was 35 mph.

A two-phased actuated signal plan was applied in the field test. For each phase, the minimum green time was 20s and the maximum green time was 40s. The yellow time was 4s for all phases. We assume the distance between the stop line and the nearest upstream detector was 50m. The passage time (i.e., green extension) was then set to 3s. The configuration on the signal plan has been set up in the traffic signal controller, i.e. Econolite ASC/3-2100, which was deployed within a signal trailer in Fig. 5.11(b). This traffic signal controller was also connected to a separate PC that translates the controller output into the SPaT messages (following the SAE J2735 standard). These messages were then sent from the SPaT PC to the Dedicated Short Range Communication (DSRC) modem, which broadcast the SPaT information at 10 Hz.

As shown in Fig. 5.11(c), when the test vehicle approached within the DSRC range, the on-board DSRC unit received the SPaT messages and transmitted them to the on-board PC. That PC integrated the SPaT, radar detection and vehicle dynamics (via the on-board diagnostics reader) to compute the recommended speed. The recommended speed was finally shown in the 7-inch monitor, along with the distance to the intersection and signal count-down information.



**(a) Field study location in Palmyrita Ave, Riverside California**



**(b) Test vehicle and portable signal trailer used in the Riverside field study**



**(c) Roadside and on-board components in the EAD system**

**Fig. 5.11 Field Test at Palmyrita Ave, Riverside**

To comprehensively evaluate possible signal and traffic conditions for eco-approach and departure at an actuated-signalized intersection, we defined four typical scenarios at Palmyrita Ave, Riverside as shown in Table 5.7, For each scenario, we ran the experiment and collected the trajectory data for both informed and uninformed drivers.

**Table 5.7 Four traffic scenarios for EAD test**

|             |               | Cross street   |  |
|-------------|---------------|--|--|
|             |               | Mild traffic   | Heavy traffic  |
| Main street | Mild traffic  | <b>①</b> Minimum green<br>Minimum red<br>Likely to be leading vehicle<br>Target speed display: On    | <b>②</b> Minimum green<br>Maximum red<br>Likely to be leading vehicle<br>Target speed display: On    |
|             | Heavy traffic | <b>③</b> Maximum green<br>Minimum red<br>Likely to be following vehicle<br>Target speed display: Off | <b>④</b> Maximum green<br>Maximum red<br>Likely to be following vehicle<br>Target speed display: Off |

Traffic Scenario 1: Mild Traffic for Main Street and Cross Street

In this traffic scenario, we tested the situation when the traffic from all directions was light and the test vehicle did not follow any other vehicles. In addition, we further assumed that all queues could be discharged during the minimum green time. No green extension was actuated for each phase. For the study phase along the main street, the green time was 20s (minimum green), the yellow time was 4s, and the red time was 24s (20s for minimum green in the other phase, 4s for yellow).

In the field test, the test vehicle entered the DSRC communication range or intersection test zone (i.e. 300m far from the stop line) at different time points throughout the entire signal cycle (every 10-seconds). The drivers were able to see the signal state for the signal trailer or the count-down display from the monitor. We tested two different entry speeds, 35 mph and 25 mph. Here the entry speed was defined as the speed when the vehicle was 300m from the stop line. To precisely control the time and speed as the vehicle entered the intersection test zone, we started the test runs at the roadside parking lot that was 400m away from the stop line. The vehicle left the curb about 10s ahead of the target entry time, and then accelerated to the entry speed before entering the intersection test zone.

Traffic Scenario 2: Mild Traffic for Main Street, and Heavy Traffic for Cross Street

The first scenario associated with the case where no green extension was made during the test for both main street and cross streets. Next we tested the scenario when the traffic was mild for the main street, but was heavy for the cross street. Since the main street traffic (where the test vehicle was traveling) was light, it was reasonable to assume the test vehicle does not follow any other vehicle. The green time for the cross street phase then extends to the maximum value. Therefore, for the study phase, the green time is 20s, the yellow time is 4s, and the red time is 44s (40s for maximum green in the other phase, 4s for yellow).

Note that in this experiment, the vehicle extensions were triggered by manually pressing the touchpad, so we had to apply the same green extension strategy to the controller cycle by cycle. In that manner, we can guarantee a consistent and repeatable signal actuation input. However, it is still different from the condition under fixed signal timing, as the eco-approaching algorithm made decisions dynamically based on both minimum and maximum remaining time rather than a fixed count-down information when approaching. We also tested the performance of the radar and state machine when the study vehicle was following another vehicle in Traffic Scenario 3 and 4.

*Traffic Scenario 3: Heavy Traffic for Main Street and Mild Traffic for Cross Street*

In this scenario, we tested the radar-based safe headway detection module. This module may work under multiple circumstances, e.g. 1) The study vehicle approached to the end of the queue during the red time; 2) The study vehicle approached to a slower vehicle in front; 3) Other vehicles cut in front of the study vehicle or the study vehicle changed its lane.

As the preceding vehicle in this test was assumed to be an unequipped one without any positioning or communication devices, it was difficult to precisely control its position when it was moving or even changing lanes. Therefore, in this study we only considered the first circumstance by introducing a stopped vehicle as the preceding vehicle. Note that the queuing scenarios only happened when the study vehicle approached to the intersection in the red time (i.e. stop if no vehicles in front). We do not need to consider the other cases that the vehicle arrived during the green time and passed the intersection without any stop or delay.

The green time for the main street phase extended to the maximum value. For the other phase, the green time was the minimum due to the light traffic. For the study phase, the green time was 40s, the yellow time was 4s, and the red time was 24s.

*Traffic Scenario 4: Heavy Traffic for Main Street and Cross Street*

In the last scenario, the traffic for all directions were assumed to be congested, so that the green times extended to the maximum for both phases. Similar to Traffic Scenario 3, the test vehicle was assumed to approach the end of the queue during the red time. Another vehicle that stopped near the intersection was introduced to trigger the radar detection.

The green times for the main street and cross street phase extended to the maximum values. For the study phase, the green time was 40s, the yellow time was 4s, and the red time was 44s. The cycle length reached its maximum (88s) for this scenario.

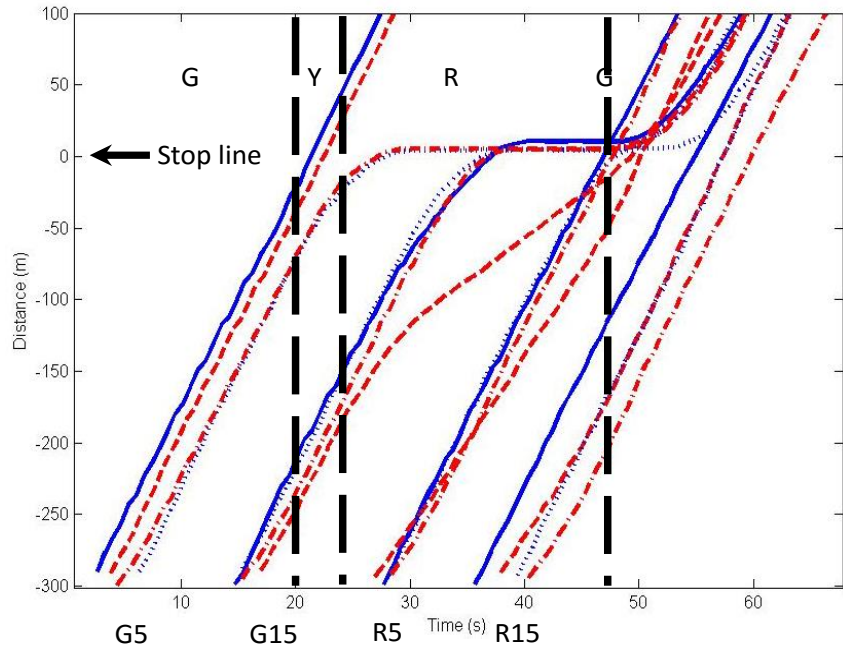
In the field test at Palmyrita Ave, Riverside, CA, the test runs were classified into two categories – informed and uninformed. The informed drivers approached and departed from the intersection by following the recommended speed from the EAD system. The uninformed drivers passed the intersection in a normal fashion without any guidance. We assumed the uninformed drivers were untrained and time saving oriented. For both informed and uninformed runs, the second-by-second vehicle trajectories were archived for data analysis in this section. The drivers were asked to enter the intersection test zone at a specific time and speed. In the test, that instruction might not be perfectly followed.



The errors for entry time were about  $\pm 2s$ , and the errors for entry speed were about  $\pm 3\text{mph}$ .

*Leading vehicle: Traffic Scenario 1 and 2*

We first discuss Traffic Scenario 1 and 2 – two scenarios that the test vehicle was the leading vehicle in a light traffic street. For Scenario 1, as shown in Fig. 5.12, four different entry times in a cycle were tested: the 5th second in Green (G5), the 15th second in Green (G15), the 5th second in Red (R5), and the 15th second in Red (R15). Starting from each entry time, four curves are plotted based on the trajectories of four driving patterns: solid curves (informed drivers, 35 mph as the entry speed), dashed curves (informed drivers, 25 mph), dotted curves (uninformed drivers, 35 mph) and dash-dot curves (uninformed drivers, 25 mph).



**Fig. 5.12 Vehicle trajectories for traffic scenario 1**

For different entry time and speed, different driving behaviors can be found from Fig. 5.12. For G5 case, two informed vehicles accelerated or maintained speed to pass the intersection before the signal turns red, while the uninformed vehicles had to stop for the next green phase. According to Table 5.8, the energy savings for 35mph and 25mph entry speed are 43% and 20%, respectively. However, this significant improvement could be partially explained by the minor difference in entry time, as the vehicle just arrived at the intersection during the yellow time.

**Table 5.8 Energy saving percentage for traffic scenario 1**

|       | G5   | G15 | R5   | R15  | Avg. | Avg. exclude G5 |
|-------|------|-----|------|------|------|-----------------|
| 35mph | 43.4 | 13  | 34.1 | -9.3 | 20.3 | 12.6            |
| 25mph | 19.5 | 8.3 | 5.2  | 6.4  | 9.9  | 6.6             |

For G15 case, when the entry speed was 35 mph, the informed vehicle decelerated earlier to prepare for a smooth and comfortable stop. When the entry speed was 25 mph, the informed vehicle slowed down 150m in front of the stop line to follow a non-stop trajectory plan. The energy reduction is about 10% for both entry speeds.

If the test vehicle arrived at the beginning of the red time (R5), the informed vehicle could anticipate the starting time of the upcoming green time and control its speed to pass the intersection without a stop or significant deceleration. As the stop was avoided, a considerable amount of environment benefits were achieved when the entry speed was 35 mph. When the entry speed was 25 mph, the informed vehicle chose to speed up when the green window was guaranteed. That late-acceleration mode would make the travel time slightly increased and the energy slightly reduced. For R15 case, as the vehicle could directly pass the intersection without any delay, the informed drivers do not have substantial advantage compared with uninformed drivers. The only improvement could be made from wisely accelerating to the speed limit if the entry speed was low.

In general, the energy savings are 20% for 35 mph entry speed and 10% for 25 mph, respectively. If we ascribe the large improvement for G5 case to the difference in arrival time, the percentage energy saving is still 13% and 7% respectively.

We then apply similar method to Scenario 2 in which the red time extended to 44s. As shown in Table 5.9, the percentage energy savings are 5% and 13% for 35 mph and 25 mph entry speed, respectively.

**Table 5.9 Energy saving percentage for traffic scenario 2**

|       | G5   | G15  | R5  | R15  | R25  | R35  | Avg. |
|-------|------|------|-----|------|------|------|------|
| 35mph | 40.3 | -8.4 | 3.8 | -9.8 | 5.9  | -0.8 | 5.2  |
| 25mph | 41.1 | 12   | 7.1 | 7.1  | 10.2 | -0.8 | 12.8 |

Following vehicle in a queue: Traffic Scenario 3 and 4

When the test vehicle was traveling in the heavy traffic, the EAD system may frequently turn off the display of recommended speed due to queues and slow vehicles. In this study, we design a specific situation. A preceding vehicle stopped 20m from the stop line during the red time. The test vehicle then approached the intersection, then decelerated and stopped after the front vehicle. For both informed and uninformed vehicles, we collected and compared the vehicle trajectories before the full stop. The trajectories for the waiting and acceleration were not considered because the target speed was not displayed and the informed driver was not guided by EAD system after the stop.

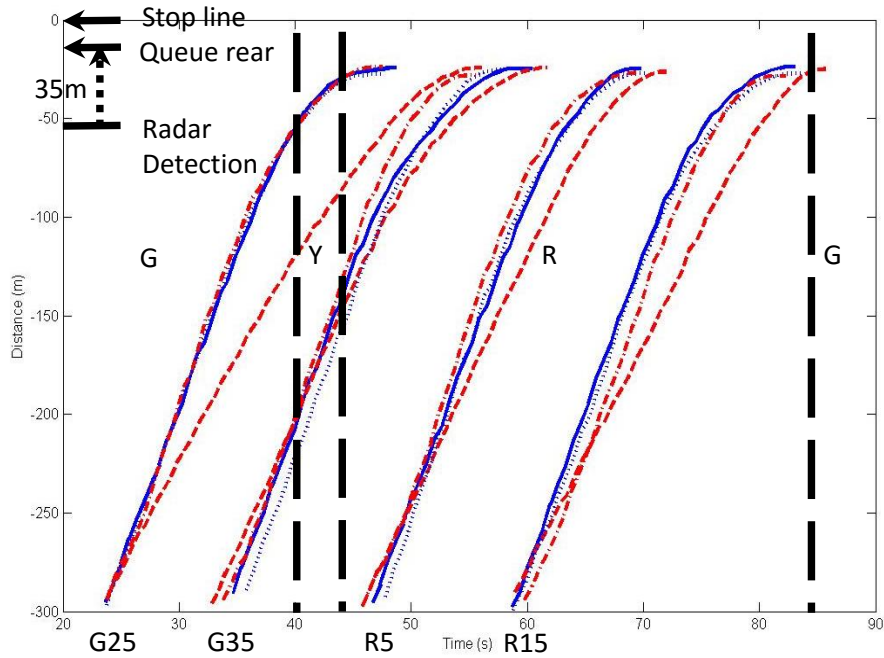
**Table 5.10 Energy saving percentage for traffic scenario 3**

|       | G25  | G35  | Avg. |
|-------|------|------|------|
| 35mph | 11.6 | 8.5  | 10   |
| 25mph | 15.3 | 37.3 | 26.3 |

**Table 5.11 Energy saving percentage for traffic scenario 4**

|       | G25  | G35  | R5   | R15  | Avg. |
|-------|------|------|------|------|------|
| 35mph | 0.7  | -2.1 | 17.8 | 10.2 | 6.6  |
| 25mph | 25.8 | 20.3 | 32.6 | 25   | 25.5 |

Although the preceding vehicle somewhat interrupted the designed trajectory plan for the informed vehicle, we can still find the benefits of the EAD system from Fig. 5.13, Table 5.10 and Table 5.11. In Fig. 5.12, we show the informed and uninformed vehicle trajectories with different entry time and entry speed for Traffic Scenario 4. When the entry speed was 35 mph, the informed vehicle had a relatively smoother deceleration trajectory. When the preceding vehicle was within the range of accurate detection (35m), the drivers would make further deceleration by their own judgment to stop right behind the preceding vehicle. According to Table IV and V, the energy savings are 10% for Scenario 3 and 7% for Scenario 4, respectively.



**Fig. 5.13 Vehicle trajectories for traffic scenario 4**

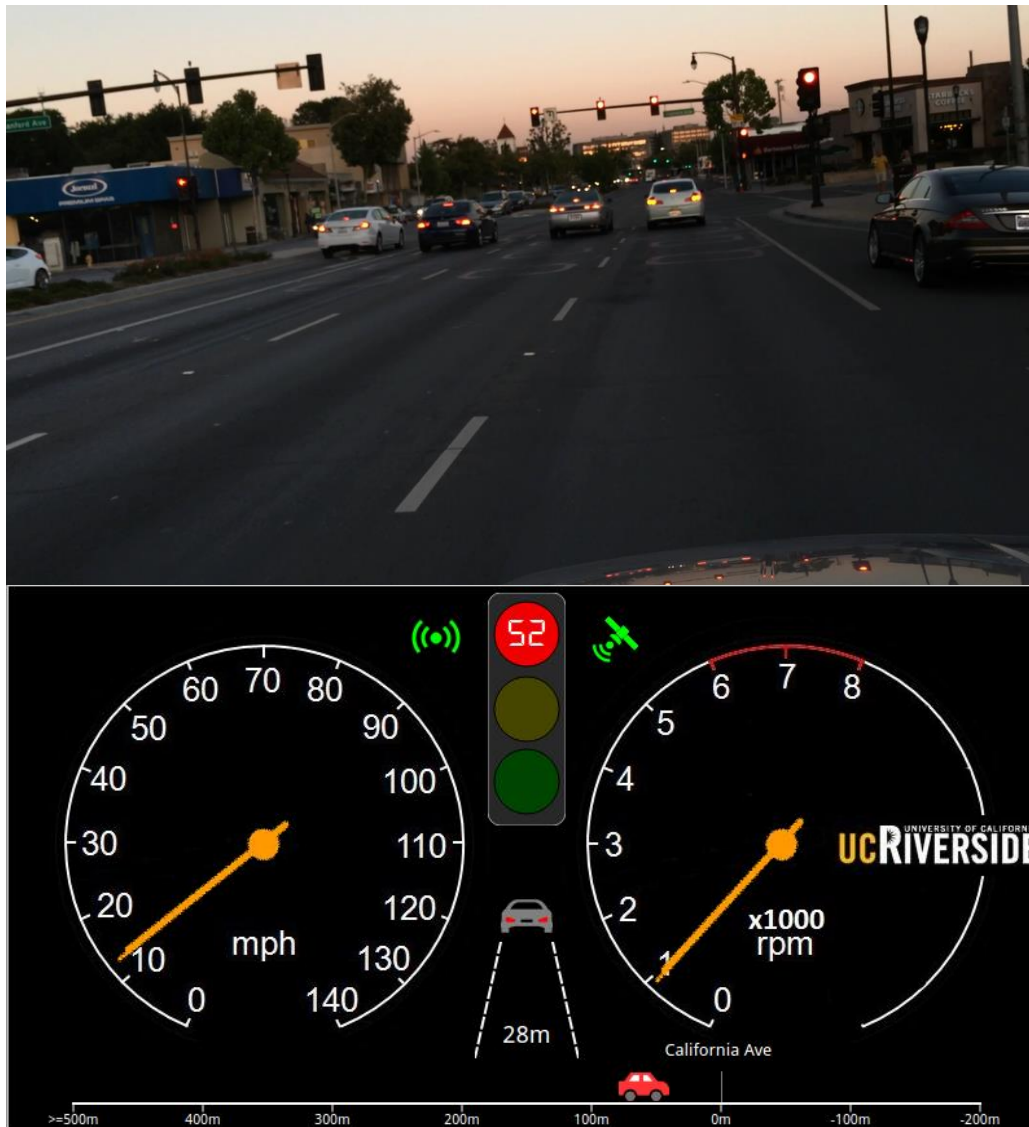
When the entry speed was 35 mph, the energy savings for informed vehicle are more significant (i.e. about 25% for both Traffic Scenario 3 and 4). The major reason is that the informed vehicles would anticipate the upcoming stop and did not accelerate any more. Instead, the uninformed vehicle might have some redundant acceleration and deceleration when approaching the queues.

### **5.2.3 Field Test in El Camino Real**

The field test in El Camino Real was conducted in the afternoon and evening of July 16<sup>th</sup>, 2015. The test vehicle traveled through the El Camino Real and passed the intersection of California Ave, Cambridge Ave, and Stanford Ave, repetitively.



(a) Case 1: target speed displayed, no preceding vehicle

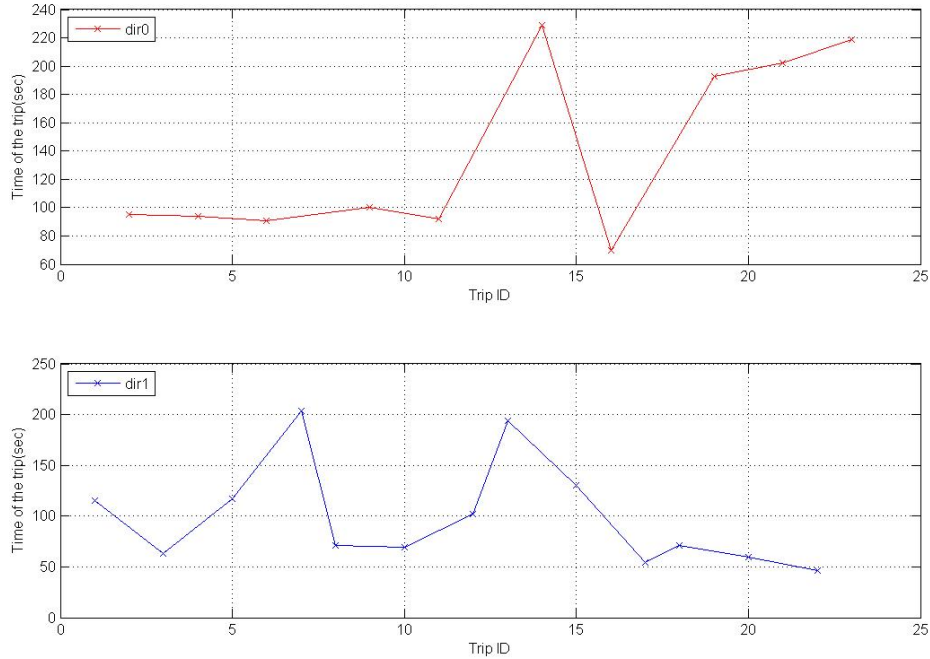


**(b) Case 2: with preceding vehicle, target speed not displayed**

**Fig. 5.14 Two scenarios for EAD implementation in El Camino Real field test**

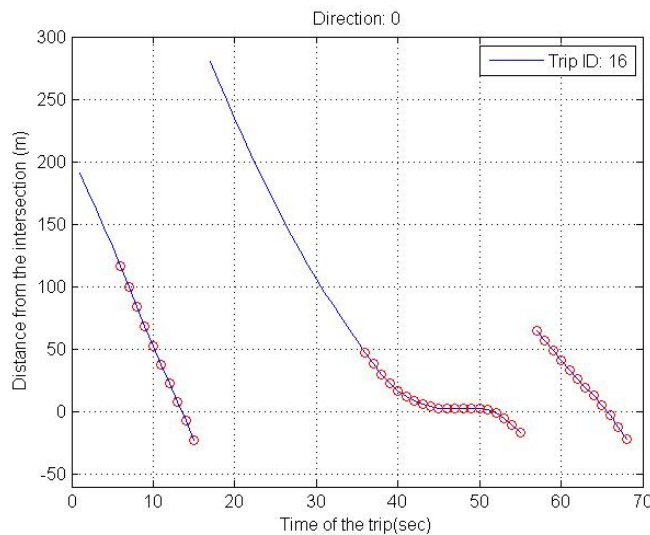
As shown in Fig. 5.14, the equipped EAD system successfully detected the SPaT information and preceding vehicle activities, and showed the correct suggestion for driving in real time. In Fig. 5.14(a), the study vehicle approached to the intersection in the red time (28s left), so the EAD system suggested a smooth stop at the stop line. In Fig. 5.14(b), the vehicle joined a queue in the red time, the distance to the preceding queued vehicle was then displayed, without any distraction from the target speed.

In total 23 trips were collected, 12 for the southbound (Stanford - California) and 11 for the northbound (California - Stanford). Figure 5.7 shows the travel times of southbound trips (upper) and northbound trips (lower), respectively. The average travel time for the southbound trips is 138.5s and the average travel time for the northbound trips is 99.7s. Generally, the southbound traffic was more congested than the northbound traffic during the data collection period.

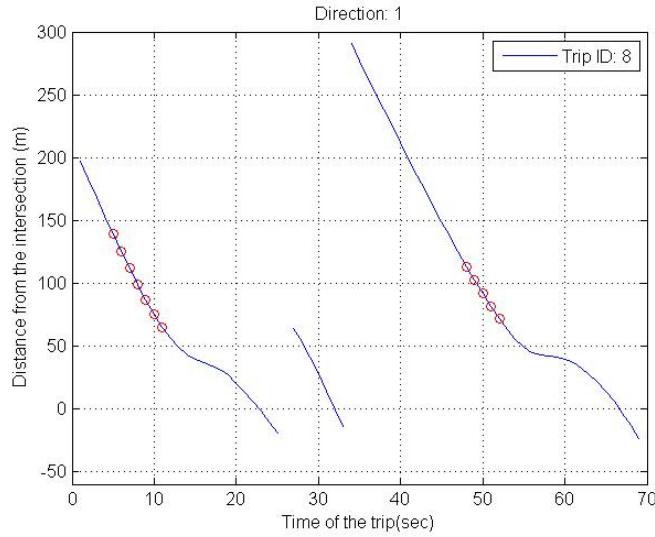


**Fig. 5.15 Travel times of southbound (upper) and northbound trips (lower)**

During the field test, the second-by-second trajectories and speed profiles were recorded. Fig. 5.16 shows the trajectories of two trips – the upper figure for the southbound and the lower one for the north bound. In these figures, the x coordinates represent the times into the trip, and the y coordinates represent the distance to the upcoming intersection. As there are three intersections in the test corridor, we show three trajectory segments in each figure. We also use circles to represent the time periods when the target speed displays were on. If the test vehicle was close to the preceding vehicle or there was no DSRC signals from the downstream intersection, the target speed display was turned off and the drivers made decisions by themselves.



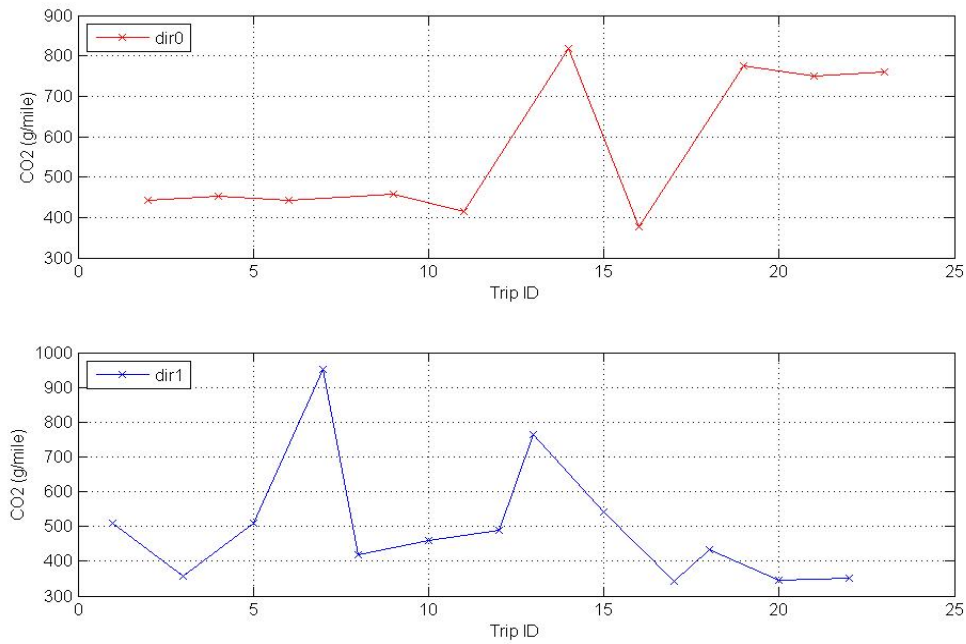
**(a) Southbound**



**(b) Northbound**

**Fig. 5.16 Second-by-second trajectories for the field test**

Based on the second-by-second speed profiles, we also study the environmental sustainability performance of the proposed EAD algorithm for actuated signals, including energy consumption, CO<sub>2</sub> and other pollutants emissions. In Fig. 5.17, we show the average CO<sub>2</sub> emissions estimated from MOVES (MOTOR Vehicle Emission Simulator) by U.S. Environmental Protection Agency (USEPA). For the southbound trips, the average is 569.5 g/miles. For the northbound trips, the average is 498.0 g/miles. Generally, the trips with higher travel times have higher emissions and fuel consumption.



**Fig. 5.17 Average CO<sub>2</sub> emission of southbound (upper) and north bound trips (lower).**

## 6 Summary

### 6.1 Project Summary

The goal of an intersection Eco-Approach and Departure assistant system is to move the driver and vehicle through an intersection, or series of intersections, in the most fuel efficient way possible, while still balancing safety and roadway throughput capacity. Since accelerating from a stop is fuel intensive, obtaining the most fuel efficient path through an intersection is best accomplished by reducing the number of stops, and the duration of time that any vehicle must spend coming to a complete stop. Alternatively, if a vehicle must stop at an intersection, fuel efficiency can be increased by instructing the driver to increase the amount of time spent coasting and limit the acceleration used once the signal turns green. In both of the intersection approach cases, the eco-driving assistance provided to drivers is primarily feed-forward advice, intended to persuade the driver into approaching the intersection in a more fuel efficient manner.

For the EAD assistant system, the information obtained from V2I communication and on board devices is the driven factor to achieve an economical trip, which contains the signal remaining time contained in messages of SPaT, the real time geographic location projecting on an intersection map, and the relative status with respect to the preceding vehicle. The goal of the system setup, including roadside system and on board system, is to provide this information in real time and follow the existing standards.

On the infrastructure side, the eleven-intersections test bed at El Camino Real, Palo Alto, California and its facilities are established and fully functional for the DSRC communication, which enables the vehicles equipped with DSRC on-board devices to obtain and benefit from the signal and traffic information. On the vehicle side, besides the DSRC OBU, the OBD-II sensor, the GPS receiver, and the frontal radar, which are responsible for getting the vehicle's information of fuel consumption, geographic location and parallel traffic respectively, are mounted and operated. Based on these system setups, this project has conducted a large amount of field tests to achieve the following conclusions.

As one of the conclusions, this project has made explanations on EAD mechanism from the following viewpoint: the EAD getting benefits from recommendations is to guide driver to realize the transition from non-beneficial scenario (I2, I5) to beneficial scenario (I1, I6).

Summarized from the field test results, the fuel saving performance varies from 0 to 22 percent for different scenarios; the three scenarios of "speed up to pass (during green)", "have to stop (from green to red)" and "maintain speed to pass (from red to green)" can potentially make improvement by following EAD assistant recommendations. From the viewpoint of newly introduced information by the assistant system, under these three scenarios, the EAD information suggests the driver's action differ from or against the normal behavior when he/she only catches the traffic signal by eyes.



Meanwhile we present two conclusive deductions for this project. First, the driving trend resulting in scenario transition plays a more critical role than the quantitative recommendation on speed or acceleration. Second, the achievable benefit of the EAD system cannot be simply concluded without considering the proportion and importance of all pre-defined scenarios.

Having considered the occurrence chance of every scenario, the statistical results show that the real achieved benefit for the tests (3%~4%) on the corridor test bed is not as significant as those presented in the previous studies (normally 10%~20%), which also means that the very moderate fuel saving benefits for driving along a corridor with coordinated signals would be expected because the chance a vehicle can encounter the beneficial scenarios and conditions is relatively low.

## **6.2 Further Research Topics and Recommendations**

### *Approaches to handle inaccurate signal remaining time*

By comparing with the previous studies, this project is dealing with actuated traffic signals as a new research task. As an outcome, the estimated signal remaining time was directly used both in the trajectory planning algorithm and the DVI displays. However, to the best of our knowledge, the estimation of actuated signal remaining time cannot guarantee one hundred percent accuracy at early stages of a signal phase due to the real time actuation of demanding traffic. Then two perspectives of issues handling the inaccurate countdown information could be raised:

1. How to define and introduce statistical countdown values into the algorithms and the final interface? The statistical representation may include probabilities and confidence interval. Concerning the DVI elements, the symbols of fuzzy value or interval value, like “30+” or “8~12”, can be considered as a substitute for a single number.
2. Could any graphic interface elements be designed to indicate the signal remaining time instead of the number display in order to avoid inevitable numeric jumps, which are caused by unpredictable green extension or red shortening?

### *Eco-driving through successive intersections with coordinated signals*

Although the California test bed is a multi-intersection corridor equipped with a coordinated signal system, the algorithms proposed in this project have treated all the intersections as independent and undifferentiated. From the test data, it can be found that the signal of next intersection may have an effect on the driving behavior during the approach to the first intersection, especially when the distance between the two successive intersections is small and the first one happens to be under the free flow traffic. This kind of scenarios occur frequently and would have an impact on the overall fuel saving performance.

Moreover, if the signals are coordinated, some kind of driving behavior is suggested beforehand, such as keeping an adequate speed to reduce the number of stops resulting in more efficient travel. That means the speed trajectory planning for EAD application must

take these assumptions of driving constraints and prior travel suggestions into consideration.

Therefore, the study of EAD applications can be extended to the situation of dependent intersections and coordinated signals.

*Deep investigation on driver-vehicle interaction and interface*

As long as the driving involves human drivers rather than full automation, the research on DVI will always be critical for such kind of technologies. Even though we paid attention to the importance of DVI design in this project, several issues have not been investigated or discovered for the practicality of the whole system.

1. How do the different types of Driver-Vehicle Interfaces and their display elements get driver's attention? In what manner do drivers respond to such DVI information reflecting on their following actions?
2. The specific DVI designs regarding driver's distraction and understanding for intersection applications.
3. Through the future studies on DVI distraction, could the DVI design be simpler and more straightforward than the existing designs?

*Cooperating with other signalization technologies for further fuel saving*

The test bed corridor has been equipped with communication facilities that enable many DSRC applications. A large part of these applications have the same goal to help subject vehicles make smoother trips. For example, the application of signal priority can make a vehicle save travel time by dispatching more green time to it. However, in the meantime, if the vehicle is also equipped with an EAD assistant, the fuel saving performance will be more significant because the contributions come from both the infrastructure and vehicle side.

## References

- [1] M. Li, K. Boriboonsomsin, G. Wu, W. Zhang, and M. J. Barth, "Traffic Energy and Emission Reductions at Signalized Intersections: A Study of the Benefits of Advanced Driver Information", *International Journal of ITS Research*, June 2009
- [2] Barth, M., Mandava, S., Boriboonsomsin, K., Xia, H, "Dynamic ECO-driving for arterial corridors," *Integrated and Sustainable Transportation System (FISTS)*, 2011 IEEE Forum on , vol., no., pp.182-188, June 29 2011-July 1 2011
- [3] Xia, H., Boriboonsomsin, K., Barth, M. (2011). "Indirect Network-wide Energy/Emissions Benefits from Dynamic ECO-Driving on Signalized Corridors", *Intelligent Transportation Systems (ITSC)*, 2011 14th International IEEE Conference, pp 329 – 334.
- [4] B. Asadi, A. Vahidi, "Predictive Use of Traffic Signal State for Fuel Saving". 12th IFAC Symposium on Transportation Systems Redondo Beach, CA, USA, September, 2009.
- [5] B. Asadi, A. Vahidi, "Predictive Cruise Control: Utilizing Upcoming Traffic Signal Information for Improving Fuel Economy and Reducing Trip Time". *IEEE Transactions on Control System Technology*, 2010.
- [6] H. Xia, K. Boriboonsomsin, F. Schweizer, A. Winckler, K. Zhou, WB. Zhang, M. Barth, "Field Operational Testing of ECO-Approach Technology at a Fixed-Time Signalized Intersection", *Proceedings of the IEEE 2012 Intelligent Transportation Systems Conference*, Anchorage, AK, September 2012, 6 pp.
- [7] J. Bonneson, S. Sunkari, M. Pratt and P. Songchitruksa. *Traffic Signal Operations Handbook*, Second Edition. Oct. 2011. Available online at <http://d2dtl5nnlpfr0r.cloudfront.net/tti.tamu.edu/documents/0-6402-P1.pdf>
- [8] Evans, L. (1979). Driver behavior effects on fuel consumption in urban driving. *Human Factors*, 21(4), pp. 389-398.
- [9] J2735 ASN.1 Specification, revision number DSRC\_R36. Available online at [http://www.sae.org/standardsdev/dsrc/usa\\_2009/DSRC\\_R36\\_Source.ASN](http://www.sae.org/standardsdev/dsrc/usa_2009/DSRC_R36_Source.ASN).
- [10] Battelle Memorial Institute, Signal Phase and Timing and Related Message Binary Format (BLOB) Details, DRAFT, Rev. c, 2012
- [11] Birrell, S.A. and Fowkes, M. (2014). Glance behaviours when using an in-vehicle smart driving aid: A real-world, on-road driving study. *Transportation Research Part F*, 22, pp. 113-125.
- [12] Birrel, S.A. and Young, M.S. (2011). The impact of smart driving aids on driving performance and driver distraction. *Transportation Research Part F*, 14, pp. 484-493.
- [13] Dogan, E., Steg, L., and Delhomme, P. (2011). The influence of multiple goals on driving behavior: The case of safety time savings, and fuel savings. *Accident Analysis and Prevention*, 43, pp. 1635-1643.
- [14] Fricke, N. and Schießl, C. (2011). Encouraging Environmentally Friendly Driving Through Driver Assistance: The Ecomove Project. *PROCEEDINGS of the Sixth International Driving Symposium on Human Factors in Driver Assessment, Training and Vehicle Design*. Iowa City, IA: The University of Iowa, Public Policy Center.
- [15] Haworth, N., & Symmons, M. (2001, December). *The relationship between fuel economy and safety outcomes* (Report No. 188). Victoria, Australia: Monash University, Accident Research Center.

- [16] Hof, T., Conde, L., Garcia, E., Iviglia, A., Jamson, S., Jopson, A., Lai, F., Merat, N., Nyberg, J., Rios, S., Sanchez, D., Schneider, S., Seewald, P., van der Weerd, C., Wijn, R., and Zlocki, A. (2014). *ecoDriver: A State of the Art Review and User's Expectations* (Technical Report for European Commission under the Framework 7 Programme). Leeds, UK: University of Leeds. Available: <http://www.ecodriver-project.eu/assets/Deliverables/June-2014/SP-1/D111-A-state-of-the-art-review-and-users-expectationsfinal.pdf>
- [17] Jenness, J.W., Singer, J., Walrath, J., Lubar, E. (2009). *Fuel economy driver interfaces: Design range and driver opinions* (Task 1 and Task 2 Technical Report DOT HS 811 092). Washington DC: U.S. Department of Transportation, National Highway Traffic Safety Administration.
- [18] Kircher, K., Fors, C., and Ahlstrom, C. (2014). Continuous versus intermittent presentation of visual eco-driving advice. *Transportation Research Part F*, 24, pp. 27-38.
- [19] Konstantopoulos, P., Chapman, P., and Crundall, D. (2010). Driver's visual attention as a function of driving experience and visibility. Using a driving simulator to explore drivers' eye movements in day, night and rain driving. *Accident Analysis and Prevention*, 42, pp. 827-834.
- [20] Manser, M.P., Rakauskas, M., Graving, J., and Jenness, J.W. (2010). *Fuel Economy Driver Interfaces: Develop Interface Recommendations* (Task 3 Technical Report DOT HS 811 319). Washington DC: National Highway Traffic Safety Administration.
- [21] NHTSA. (2013). *Visual-Manual NHTSA Driver distraction Guidelines for In-vehicle Electronic Devices* (Docket No. NHTSA-2010-0053). Washington DC: U.S. Department of Transportation, National Highway Traffic Safety Administration.
- [22] Staubach, M., Schebitz, N., Köster, F., and Kuck, D. (2014). Evaluation of an eco-driving support system. *Transportation Research Part F*, 27, pp. 11-21.
- [23] Seewald, P., Ahlström, C., Aleksic, M., Fors, C., García, E., Hibberd, D., Iviglia, A., Jamson, S., Jamson, H., Josten, J., Kircher, K., Kroon, L., Masala, A., Nogueira, A., Saint Pierre, G., Santoro, G. (2013). *ecoDriver: Results of HMI and Feedback Solutions Evaluations* (Technical Report for European Commission under the Framework 7 Programme). Leeds, UK: University of Leeds. Available: <http://www.ecodriver-project.eu/assets/Deliverables/Nov-2013/SP1/D132-Results-of-HMI-and-feedback-solutions-evaluationssubmitted.pdf>
- [24] Seewald, P. and Stuiver, A. (2014). *ecoDriver Evaluation Plan and Scenario Definition* (Technical Report for European Commission under the Framework 7 Programme). Leeds, UK: University of Leeds. Available: <http://www.ecodriver-project.eu/assets/Deliverables/June-2014/SP-1/D131-Evaluation-plan-and-scenario-defintionfinal.pdf>
- [25] P. M. d'Orey and M. Ferreira, "ITS for sustainable mobility: A survey on applications and impact assessment tools," *Intelligent Transportation Systems, IEEE Transactions on*, vol. 15, pp. 477-493, 2014.
- [26] P. L. J. Morsink, N. van Nes, L. Walta, and V. Marchau, "In-Car Speed Assistance to Improve Speed Management," in 15th World Congress on Intelligent Transport Systems and ITS America's 2008 Annual Meeting, ITS America, 2008.
- [27] M. Paine, D. Paine, M. Griffiths, and G. Germanos, "In-vehicle intelligent speed advisory systems," in Proc. of the 20th Int. Conf. on the Enhanced Safety of Vehicles, 2007.
- [28] O. M. J. Carsten and F. N. Tate, "Intelligent speed adaptation: Accident savings and cost-benefit analysis," *Accident Anal. Prev.*, vol. 37, no. 3, pp.407 -416 2005.
- [29] Y. He, X. Yan, C. Wu, M. Zhong, D. Chu, Z. Huang, et al., "An evaluation of the effectiveness of auditory speeding warnings for commercial passenger vehicles - A field study in Wuhan, China," in Transportation Research Board 93rd Annual Meeting, Transportation Research Board, 2014.

- [30] O. Servin, K. Boriboonsomsin, Matthew Barth, "An energy and emissions impact evaluation of intelligent speed adaptation", in Proc. Intelligent Transportation Systems, pp.1257-1262, 2006.
- [31] G. Saint Pierre and J. Ehrlich, "Impact of intelligent speed adaptation systems on fuel consumption and driver behaviour," in Proc. 15th World Congr. Intell. Transp. Syst., 2008, pp. 1-11.
- [32] H. Xia, "Eco-Approach and Departure Techniques for Connected Vehicles at Signalized Traffic intersections," PhD. Thesis, 2014.
- [33] K. Ahn , H. Rakha , A. Trani and M. Van Aerde, "Estimating vehicle fuel consumption and emissions based on instantaneous speed and acceleration levels," J. Transp. Eng., vol. 128, no. 2, pp.182 -190, 2002.
- [34] W. Zimdahl, "Guidelines and some developments for a new modular driver information system," in 34th IEEE Vehicular Technology Conference (VTC1984), vol. 34. Pittsburgh, PA: IEEE, May 1984, pp. 178-182.
- [35] D. Eckhoff, B. Halmos, and R. German, "Potentials and limitations of Green Light Optimal Speed Advisory systems," in Vehicular Networking Conference (VNC), 2013 IEEE, 2013, pp. 103-110.
- [36] E. Koukoumidis, M. Martonosi, and P. Li-Shiuan, "Leveraging Smartphone Cameras for Collaborative Road Advisories," Mobile Computing, IEEE Transactions on, vol. 11, pp. 707-723, 2012.
- [37] B. Asadi and A. Vahidi, "Predictive cruise control: utilizing upcoming traffic signal information for improved fuel economy and reduced trip time," IEEE transactions on control systems technology, vol. 19, pp. 707-714, 2011.
- [38] T. Tielert, M. Killat, H. Hartenstein, R. Luz, S. Hausberger, and T. Benz, "The impact of traffic-light-to-vehicle communication on fuel consumption and emissions," in Proc. Internet Things Conf., Tokyo, Japan, Nov. 2010, pp. 1-8.
- [39] M. Seredynski, W. Mazurczyk, and D. Khadraoui, "Multi-segment Green Light Optimal Speed Advisory," in Parallel and Distributed Processing Symposium Workshops & PhD Forum (IPDPSW), 2013 IEEE 27th International, 2013, pp. 459-465.
- [40] M. Seredynski, B. Dorrnsoro, and D. Khadraoui, "Comparison of Green Light Optimal Speed Advisory approaches," in Intelligent Transportation Systems - (ITSC), 2013 16th International IEEE Conference on, 2013, pp. 2187-2192.
- [41] M. Seredynski, P. Ruiz, K. Szczypiorski, and D. Khadraoui, "Improving Bus Ride Comfort Using GLOSA-Based Dynamic Speed Optimisation," in Parallel & Distributed Processing Symposium Workshops (IPDPSW), 2014 IEEE International, 2014, pp. 457-463.
- [42] K. Katsaros, R. Kernchen, M. Dianati, and D. Rieck, "Performance study of a Green Light Optimized Speed Advisory (GLOSA) application using an integrated cooperative ITS simulation platform," in Wireless Communications and Mobile Computing Conference (IWCMC), 2011 7th International, 2011, pp. 918-923.
- [43] A. Wegener, H. Hellbruck, C. Wewetzer, and A. Lubke, "VANET simulation environment with feedback loop and its application to traffic light assistance," in GLOBECOM Workshops, 2008 IEEE, 2008, pp. 1-7.
- [44] J. Erdmann, "Combining adaptive junction control with simultaneous Green-Light-Optimal-Speed-Advisory," in Wireless Vehicular Communications (WiVeC), 2013 IEEE 5th International Symposium on, 2013, pp. 1-5.
- [45] R. Bodenheimer, A. Brauer, D. Eckhoff, and R. German, "Enabling GLOSA for adaptive traffic lights," in Vehicular Networking Conference (VNC), 2014 IEEE, 2014, pp. 167-174.

- [46] V. Protschky, S. Feit, and C. Linnhoff-Popien, "Extensive Traffic Light Prediction under Real-World Conditions," in Vehicular Technology Conference (VTC Fall), 2014 IEEE 80th, 2014, pp. 1-5.
- [47] Tomer Toledo, Haris N. Koutsopoulos, Moshe Ben-Akiva, "Integrated driving behavior modeling," *Transportation Research Part C: Emerging Technologies*, vol. 15, no. 2, pp. 96-112, 2007.
- [48] T. Aono and T. Kowatari, "Throttle-control algorithm for improving engine response based on air-intake model and throttle-response model," *Industrial Electronics, IEEE Transactions on*, vol. 53, pp. 915-921, 2006.
- [49] Bart Saerens, "Optimal control based eco-driving," PhD. Thesis, 2012.
- [50] H. Raza, Z. Xu, B. Yang, and P. A. Ioannou, "Modeling and control design for a computer-controlled brake system," *Control Systems Technology, IEEE Transactions on*, vol. 5, pp. 279-296, 1997.
- [51] M. Barth and K. Boriboonsomsin, "Real-world carbon dioxide impacts of traffic congestion," *Transportation Research Record*, vol. 2058, pp. 163-171, 2008.
- [52] X. M. Ma, X. B. Chen, and H. H. Refai, "Performance and Reliability of DSRC Vehicular Safety Communication: A Formal Analysis," *Eurasip Journal on Wireless Communications and Networking*, 2009.
- [53] U.S. Environmental Protection Agency, "Motor Vehicle Emission Simulator," <http://www.epa.gov/otaq/models/moves/>. Accessed on Sept 20th, 2015
- [54] X. Xiang, K. Zhou, W. Zhang, W. Qin, Q. Mao, "A Closed-Loop Speed Advisory Model With Driver's Behavior Adaptability for Eco-Driving," in *Intelligent Transportation Systems, IEEE Transactions on*, vol.16, no.6, pp.3313-3324, Dec. 2015