

DIST	COUNTY	ROUTE	POST MILES TOTAL PROJECT	SHEET No.	TOTAL SHEETS
X	X	X	X	X	X
REGISTERED CIVIL ENGINEER			X	DATE	
PLANS APPROVAL DATE					
The State of California or its officers or agents shall not be responsible for the accuracy or completeness of electronic copies of this plan sheet.					

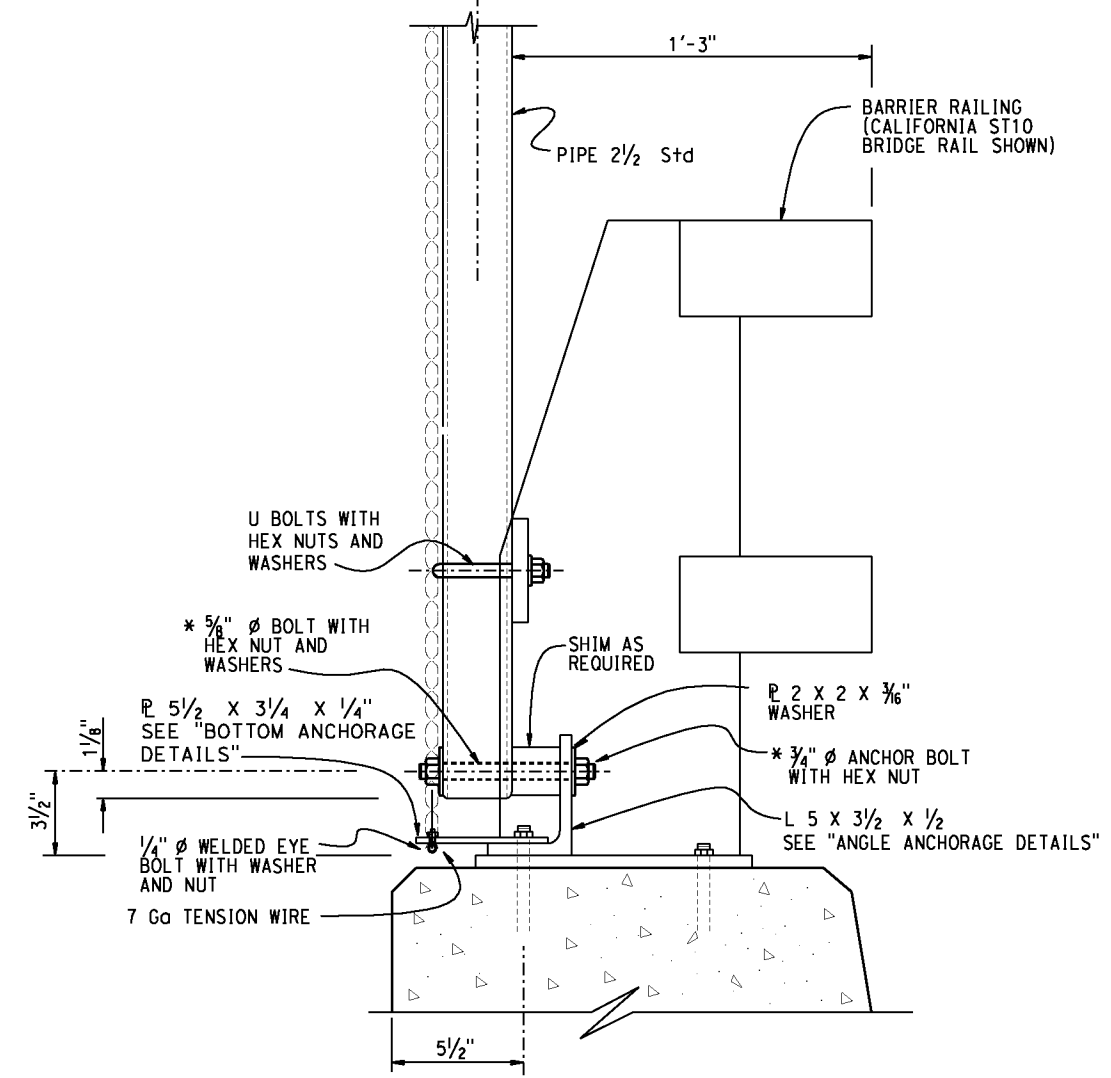
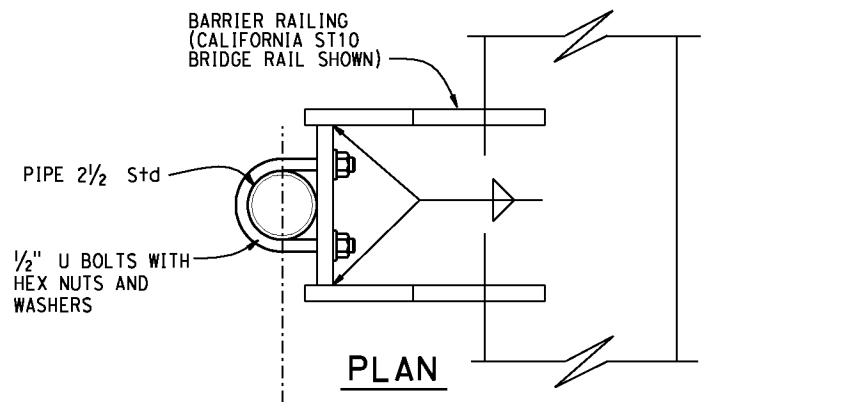
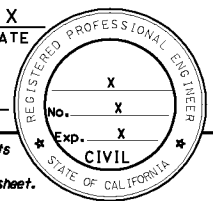

\* IF NECESSARY, SEE "NUT/BOLT EXTENSION"

**ELEVATION SECTION A-A**  
3" = 1'-0"

NOTE:  
THE CONTRACTOR SHALL VERIFY ALL CONTROLLING FIELD DIMENSIONS BEFORE ORDERING OR FABRICATING ANY MATERIAL.

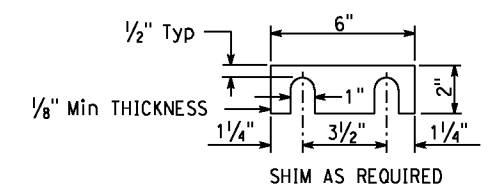

**RAILING SHIM DETAILS**  
3" = 1'-0"

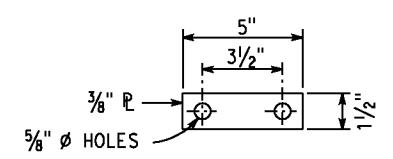

**SPACER PLATE**  
3" = 1'-0"

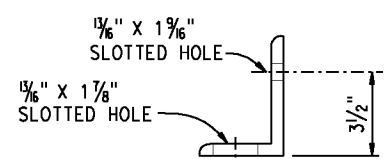
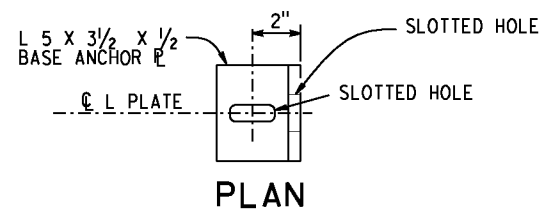

**ELEVATION ANGLE ANCHORAGE DETAILS**  
3" = 1'-0"

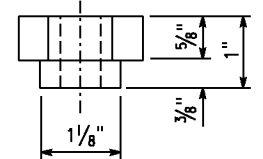
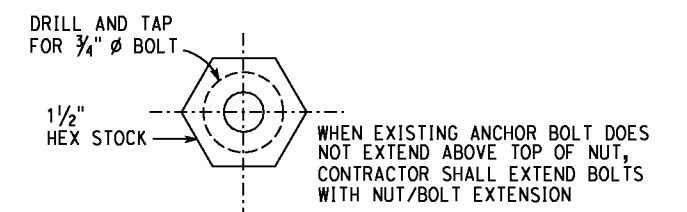

**NUT/BOLT EXTENSION**  
NO SCALE

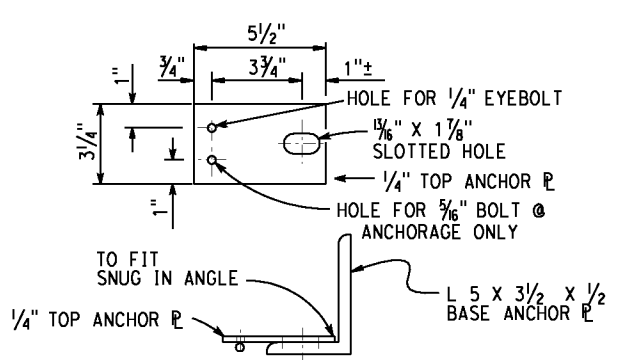

**BOTTOM ANCHORAGE DETAILS**  
3" = 1'-0"

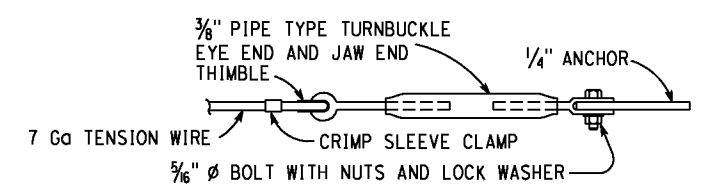

STANDARD DRAWING	
FILE NO. <b>xs16-180-2</b>	APPROVAL DATE <u>July 2011</u>

STATE OF CALIFORNIA	
DEPARTMENT OF TRANSPORTATION	

DIVISION OF ENGINEERING SERVICES	
BRIDGE NO. X	POST MILE X

X	
CHAIN LINK RAILING TYPE 4 - ST-10 - DETAILS NO. 2	