

| | | | | | |
|------|--------|-------|--------------------------|-----------|--------------|
| DIST | COUNTY | ROUTE | POST MILES TOTAL PROJECT | SHEET No. | TOTAL SHEETS |
| X | X | X | X | X | X |

REGISTERED CIVIL ENGINEER DATE: X

PLANS APPROVAL DATE: _____

The State of California or its officers or agents shall not be responsible for the accuracy or completeness of electronic copies of this plan sheet.

REGISTERED PROFESSIONAL ENGINEER
No. X
Exp. X
CIVIL
STATE OF CALIFORNIA

| DESIGN H | 8' | 10' | 12' | 14' | 16' | 18' | 20' | 22' | 24' | 26' | 28' | 30' | 32' |
|----------------------------|---------|----------|----------|---------|---------|---------|----------|----------|----------|---------|----------|----------|----------|
| W | 6'-6" | 7'-3" | 7'-9" | 8'-0" | 9'-0" | 9'-3" | 10'-3" | 11'-3" | 12'-3" | 13'-0" | 14'-3" | 15'-3" | 17'-0" |
| C | 5'-3" | 6'-0" | 6'-3" | 6'-6" | 7'-3" | 7'-3" | 8'-0" | 8'-6" | 9'-6" | 10'-0" | 10'-10" | 11'-6" | 13'-2" |
| B | 1'-3" | 1'-3" | 1'-6" | 1'-6" | 1'-9" | 2'-0" | 2'-3" | 2'-9" | 2'-9" | 3'-0" | 3'-5" | 3'-9" | 3'-10" |
| F | 2'-6" | 2'-6" | 2'-9" | 2'-9" | 2'-9" | 2'-9" | 3'-0" | 3'-0" | 3'-3" | 3'-6" | 3'-9" | 4'-0" | 4'-3" |
| STEM THICKNESS AT TOP | 1'-0" | 1'-0" | 1'-3" | 1'-3" | 1'-7" | 1'-11" | 2'-0" | 2'-0" | 2'-0" | 2'-0" | 2'-0" | 2'-3" | 2'-3" |
| BATTER | 0 | 0 | 0 | 0 | 0 | 0 | 0 | 1/4:12 | 1/4:12 | 1/4:12 | 1/2:12 | 1/2:12 | 1/2:12 |
| M | 3'-9" | 4'-6" | 4'-9" | 5'-0" | 5'-9" | 5'-9" | 6'-6" | 7'-0" | 8'-0" | 8'-6" | 9'-4" | 10'-0" | 11'-8" |
| N | 0'-3" | 0'-3" | 0'-0" | 0'-0" | 0'-3" | 0'-6" | 0'-9" | 1'-3" | 1'-3" | 1'-6" | 1'-11" | 2'-3" | 2'-4" |
| ROW 1 SPACING | 12'-0" | 12'-0" | 10'-0" | 9'-6" | 8'-0" | 7'-0" | 6'-0" | 4'-0" | 4'-0" | 4'-0" | 4'-0" | 3'-9" | 4'-0" |
| ROW 2 SPACING | 20'-0" | 20'-0" | 16'-0" | 14'-0" | 14'-0" | 12'-0" | 10'-0" | 10'-0" | 8'-0" | 4'-0" | 7'-6" | 6'-6" | 4'-0" |
| ROW 3 SPACING | | | | | | | | | | | 6'-0" | 5'-0" | 4'-0" |
| ⊙ BARS | | | | | #5 @ 14 | #6 @ 14 | #6 @ 13 | #6 @ 13 | #6 @ 11 | #7 @ 12 | #7 @ 11 | #7 @ 10 | #8 @ 11 |
| ⊖ BARS | | #5 @ 5.5 | #5 @ 4.5 | #6 @ 5 | #8 @ 7 | #9 @ 7 | #9 @ 6.5 | #9 @ 6.5 | #9 @ 5.5 | #10 @ 6 | #10 @ 11 | #10 @ 10 | #11 @ 11 |
| ha | 7'-10" | 9'-10" | 6'-0" | 6'-0" | 6'-3" | 7'-3" | 7'-6" | 9'-0" | 9'-9" | 10'-6" | 11'-3" | 12'-0" | 14'-0" |
| hb | | | | | 12'-0" | 11'-9" | 13'-0" | 14'-6" | 15'-6" | 18'-6" | 20'-6" | 21'-6" | 23'-0" |
| hx | 5'-0" | 5'-9" | 6'-0" | 6'-3" | 7'-0" | 7'-0" | 7'-9" | 8'-3" | 8'-9" | 9'-6" | 10'-7" | 10'-6" | 12'-11" |
| ⊙ BARS | #5 @ 12 | #5 @ 11 | #5 @ 9 | #5 @ 10 | #5 @ 14 | #5 @ 14 | #5 @ 13 | #5 @ 13 | #5 @ 11 | #5 @ 12 | #5 @ 11 | #5 @ 10 | #5 @ 11 |
| ⊙ BAR LENGTH | 3'-6" | 4'-6" | 4'-6" | 6'-0" | 7'-0" | 7'-0" | 7'-9" | 10'-9" | 11'-9" | 12'-6" | 13'-9" | 14'-9" | 16'-6" |
| ⊙ BARS | | | | | | | | | | | #4 @ 11 | #4 @ 10 | #4 @ 11 |
| ⊙ bar | #4 @ 12 | #4 @ 12 | #5 @ 15 | #5 @ 15 | #5 @ 12 | #5 @ 12 | #6 @ 12 | #6 @ 12 | #6 @ 12 | #6 @ 12 | #6 @ 12 | #7 @ 12 | #7 @ 12 |
| ⊙ bar | #4 @ 18 | #4 @ 18 | #4 @ 18 | #4 @ 18 | #4 @ 12 | #4 @ 12 | #4 @ 12 | #4 @ 12 | #4 @ 12 | #5 @ 12 | #5 @ 12 | #5 @ 12 | #5 @ 12 |
| H _d (k/ft), SVC | 2.6 | 3.3 | 4.2 | 5.1 | 6.2 | 7.4 | 9.0 | 10.4 | 12.5 | 14.5 | 17.0 | 19.3 | 21.8 |
| H _d (k/ft), Str | 4.1 | 5.2 | 6.6 | 8.0 | 9.4 | 11.1 | 13.4 | 16.0 | 18.8 | 21.8 | 25.6 | 29.1 | 32.8 |
| H _d (k/ft), ext | 5.0 | 6.5 | 8.6 | 10.5 | 13.0 | 15.7 | 19.0 | 22.5 | 26.3 | 30.5 | 35.7 | 41.0 | 46.5 |

LEGEND:
 ⊙ : 2 bar bundle
 H_d : Factored Horizontal Driving Force
 SVC : Service Limit State
 Str : Strength Limit State
 ext : Extreme Event Limit State

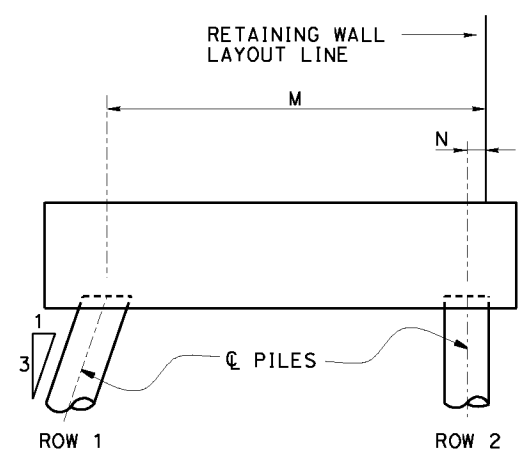

H = 8' THROUGH 14'

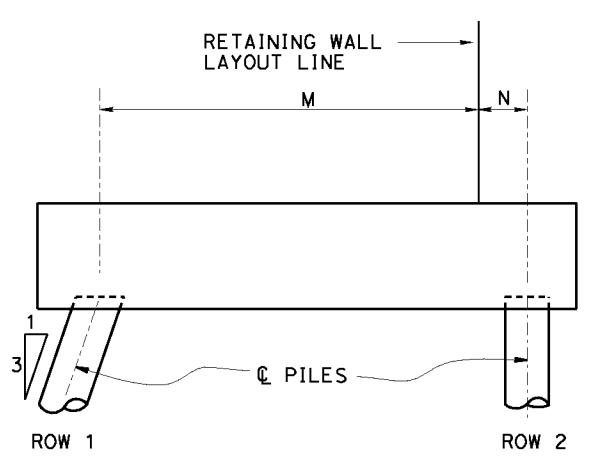

H = 16' THROUGH 26'

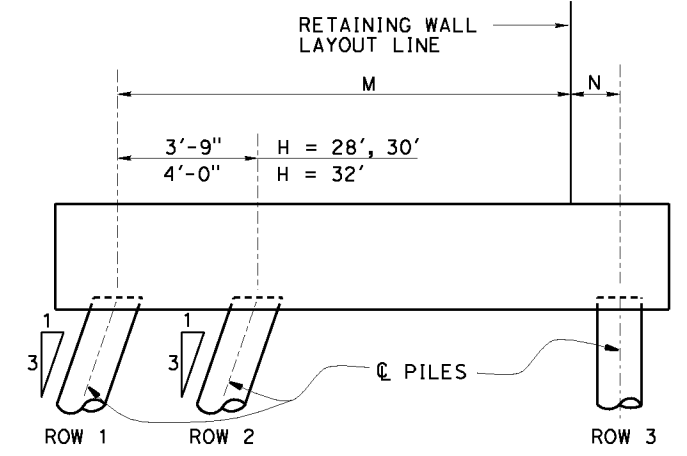

H = ≥ 28'

PILE PATTERN
No Scale

STANDARD DRAWING

FILE NO. **xs14-400-2**

APPROVAL DATE July 2011

STATE OF CALIFORNIA
DEPARTMENT OF TRANSPORTATION

DIVISION OF ENGINEERING SERVICES

BRIDGE NO. X

POST MILE X

RETAINING WALL TYPE 7SWP - DETAILS NO. 2

CONTRACT NO.: X