

ADA Notice

For individuals with sensory disabilities, this document is available in alternate formats. For information call (916) 654-6410 or TDD (916) 654-3880 or write Records and Forms Management, 1120 N Street, MS-89, Sacramento, CA 95814.

TECHNICAL REPORT STANDARD TITLE PAGE

1. REPORT NUMBER FHWA/CA15-0918	2. GOVERNMENT ACCESSION NUMBER	3. RECIPIENTS CATALOG NUMBER	
4. TITLE AND SUBTITLE DEVELOPMENT OF AESTHETIC, LOW-MAINTENANCE GUARDRAIL SYSTEM ALTERNATIVES		5. REPORT DATE November 2015	
		6. PERFORMING ORGANIZATION ROADSIDE SAFETY RESEARCH GROUP	
7. AUTHOR(S) CHRISTOPHER CALDWELL		8. PERFORMING ORGANIZATION REPORT NO. FHWA/CA15-0918	
9. PERFORMING ORGANIZATION NAME AND ADDRESS ROADSIDE SAFETY RESEARCH GROUP CALIFORNIA DEPARTMENT OF TRANSPORTATION 5900 FOLSOM BLVD. SACRAMENTO, CA 95819		10. WORK UNIT NUMBER	
		11. CONTRACT OF GRANT NUMBER FHWA/CA15-0918	
12. SPONSORING AGENCY NAME AND ADDRESS CALIFORNIA DEPARTMENT OF TRANSPORTATION 5900 FOLSOM BLVD. SACRAMENTO, CA 95819		13. TYPE OF REPORT AND PERIOD COVERED FINAL	
		14. SPONSORING AGENCY CODE	
15. SUPPLEMENTARY NOTES This project was performed in cooperation with the US Department of Transportation, Federal Highway Administration, under the research project titled "Aesthetic, Low-Maintenance Guardrail System for Rural Areas".			
16. ABSTRACT This research is an effort to provide local agencies with an aesthetic, low maintenance guardrail alternative to W-beam guardrail. The research is divided into two tasks. The first task, which is covered in this report, was to combine an aesthetically pleasing bridge rail (previously approved) with a concrete footing in order to create a new guardrail system. The second task will be to design, fabricate, and test a new guardrail system and will be covered in a future report. Caltrans' Roadside Safety Research Group (RSRG) conducted a Manual for Assessing Safety Hardware 2009 (MASH) 3-11 full scale crash test on a ST-10 bridge rail mounted on a 30-inch (762-mm) by 20-inch (508-mm) concrete trench footing foundation. To represent the worst case scenario the footing was installed in a weak soil, had a 3:1 slope cut out behind the barrier, and was constructed with a cold joint between the footing and the ST-10's curb. The ST-10 Bridge Rail consists of two 8-inch (203-mm) by 4-inch (102-mm) steel rails and a 6-inch (152-mm) concrete curb. The height of the test article was 33 inches (838 mm) and the length was 112.6 ft (34.34 m). The combination of the ST-10 bridge rail and trench footing redirected the test vehicle with minimal movement to the foundation. However, after losing contact with the barrier, the vehicle rolled onto its side. Although this combination failed MASH's evaluation criteria (criterion F), the trench footing functioned as intended. Therefore, this trench footing is recommended for use with any bridge rail designs that have either NCHRP Report 350's or MASH's Test Level 3 or Level 4 criteria. These rail/footing combinations may be considered for use on California's roadways as TL-3 guardrail.			
17. KEY WORDS Guardrail, Aesthetic, Low Maintenance, ST-10 Bridge Rail, Crash Test, Barriers, Vehicle Impact Test, Footing		18. DISTRIBUTION STATEMENT No restrictions. This document is available through the National Technical Information Service, Springfield, VA 22161	
19. SECURITY CLASSIFICATION (OF THIS REPORT) UNCLASSIFIED	20. SECURITY CLASSIFICATION (OF THIS PAGE) UNCLASSIFIED	21. NUMBER OF PAGES 110	22. PRICE

DEVELOPMENT OF AESTHETIC, LOW-MAINTENANCE GUARDRAIL SYSTEM ALTERNATIVES



STATE OF CALIFORNIA
DEPARTMENT OF TRANSPORTATION
DIVISION OF RESEARCH, INNOVATION AND SYSTEM INFORMATION
OFFICE OF SAFETY INNOVATION AND COOPERATIVE RESEARCH

Supervised by Robert Meline, P.E.
Principal Investigator John Jewell, P.E.
Report Prepared By Christopher Caldwell
Research Performed By Roadside Safety Research Group



Testing Cert # 3046.01

STATE OF CALIFORNIA
DEPARTMENT OF TRANSPORTATION
DIVISION OF RESEARCH, INNOVATION AND SYSTEM INFORMATION
OFFICE OF SAFETY INNOVATION AND COOPERATIVE RESEARCH

**DEVELOPMENT OF AESTHETIC, LOW-MAINTENANCE
GUARDRAIL SYSTEM ALTERNATIVES**

Supervised by Robert Meline, P.E.
Principal Investigator John Jewell, P.E.
Report Prepared By Christopher Caldwell
Research Performed By Roadside Safety Research Group



JOSEPH W. HORTON, P.E.
Office Chief
Office of Safety Innovation and
Cooperative Research



ROBERT MELINE, P.E.
Branch Chief
Infrastructure Methods Advancement Branch
Roadside Safety Research Group



JOHN JEWELL, P.E.
Senior Engineer Specialist
Roadside Safety Research Group



CHRISTOPHER CALDWELL
Transportation Engineer
Roadside Safety Research Group

DISCLAIMER

This document is disseminated in the interest of information exchange. The contents of this report reflect the views of the authors who are responsible for the facts and accuracy of the data presented herein. The contents do not necessarily reflect the official views or policies of the State of California or the Federal Highway Administration. This publication does not constitute a standard, specification, or regulation. This report does not constitute an endorsement by the California Department of Transportation (Caltrans) of any product described herein.

For individuals with sensory disabilities, this document is available in Braille, large print, audiocassette, or compact disk. To obtain a copy of this document in one of these alternate formats, please contact: the Division of Research, Innovation and System Information, MS-83, California Department of Transportation, P.O. Box 942873, Sacramento, CA 94273-0001.

UNCERTAINTY OF MEASUREMENT STATEMENT

The Caltrans Roadside Safety Research Group (RSRG) has determined the uncertainty of measurements in the testing of roadside safety hardware as well as in standard full-scale crash testing of roadside safety features. The results contained in this report are only for the tested article(s) and not any other articles based on the same design and/or thereof. Information regarding the uncertainty of measurements for critical parameters is available upon request to the Caltrans Roadside Safety Research Group.

METRIC SYSTEM (SI) TO ENGLISH OF MEASUREMENT

SI CONVERSION FACTORS

<u>To Convert From</u>	<u>To</u>	<u>Multiply By</u>
ACCELERATION		
m/s ²	ft/s ²	3.281
AREA		
m ²	ft ²	10.76
ENERGY		
Kilojoules (KJ)	kip-ft	0.7376
FORCE		
Newton (N)	lb _f	0.2248
LENGTH		
m	ft	3.281
m	in	39.37
cm	in	0.3937
mm	in	0.03937
MASS		
kg	lb _m	2.205
PRESSURE OR STRESS		
kPa	psi	0.1450
VELOCITY		
km/h	mph	0.6214
m/s	ft/s	3.281
km/h	ft/s	0.9113

ACKNOWLEDGEMENTS

This work was accomplished in cooperation with the United States Department of Transportation, Federal Highway Administration.

Special appreciation is due to the following staff members of the Roadside Safety Research Group (RSRG) within the Division of Research Innovation and System Information (DRISI), the Materials Engineering & Testing Services (METS) & Geotechnical Services and within the Division of Structures (DES), the Office of Design & Technical Services within the Division of Engineering Services, the Roadside Management & Landscape Architecture Standards within the Division of Design, the Division of Traffic Operations, and Photography within the Division of Public Affairs for their help on this project:

John Jewell, David Whitesel, Mike O’Keeffe, Safar Zalekian, Christopher Caldwell, Vue Her, and Rachel Kwong, test preparation, data collection, data reduction, vehicle preparation, and film processing; Darrell Chan and Dave Bengal, Independent Camera Operators; Eric Jacobson, electronic instrumentation.

Other persons from Caltrans who made importation contributions were:

Greg Kaderabek, Doug Brown, Edmund Ung, Karim Mirza, Ed Andersen, Steven Hellon, Pete Barrios, Scott Lorenzo.

TABLE OF CONTENTS

DISCLAIMER.....	I
METRIC SYSTEM (SI) TO ENGLISH OF MEASUREMENT	II
ACKNOWLEDGEMENTS.....	III
TABLE OF CONTENTS.....	IV
LIST OF FIGURES.....	VI
LIST OF TABLES.....	VIII
1 Introduction	1
1.1 Problem	1
1.2 Objective.....	2
1.3 Background.....	2
1.4 Scope	4
2 System Details.....	6
2.1 Test Article.....	6
2.2 Design Modifications during Tests	6
2.3 Material Specifications	6
2.4 Soil Specifications	6
2.5 Construction	6
3 Test Requirement and Evaluation Criteria.....	11
3.1 Crash Test Matrix.....	11
3.2 Evaluation Criteria	11
4 Test Conditions	14
4.1 Test Facilities	14
4.2 Vehicle Guidance System	14
4.3 Data Acquisition System.....	15
4.3.1 Vehicle Instrumentation and Data Processing.....	16
4.3.2 Photographic Instrumentation and Data Processing.....	19
5 Crash Test Number 130MASH3P13-03	21
5.1 Test Designation and Actual Impact Conditions – Test 130MASH3P13-03	21
5.2 Test Vehicle – Test 130MASH3P13-03	21
5.3 Weather Conditions – Test 130MASH3P13-03	22
5.4 Soil Conditions - Test 130MASH3P13-03.....	23
5.5 Test Description – Test 130MASH3P13-03.....	23
5.6 Test Article Damage - Test 130MASH3P13-03	23
5.6.1 Stringpot Measurement of Barrier Movement.....	26
5.7 Vehicle Damage – Test 130MASH3P13-03.....	27
5.8 Occupant Risk Factors – Test 130MASH3P13-03	33
5.9 Data Summary Sheet – Test 130MASH3P13-03.....	34
5.10 Assessment of Test Results for Test 130MASH3P13-03	35
5.10.1 Structural Adequacy for Test 130MASH3P13-03	35
5.10.2 Occupant Risk for Test 130MASH3P13-03	35
5.10.3 Vehicle Trajectory for Test 130MASH3P13-03	35

5.11	Discussion	37
6	Conclusions	38
7	Recommendations	39
8	Implementation	40
9	References	41
10	Appendixes.....	42
10.1	Details of Test Article	42
10.2	Test Vehicle Properties.....	50
10.3	130MASH3P13-03 Crash Test Sequence Photographs	54
10.3.1	Upstream Sequence	54
10.3.2	Across Sequence.....	55
10.4	Vehicle Angular Displacement and Accelerations.....	56
10.5	Finite Element Analysis	62
10.5.1	Barrier Models.....	63
10.5.1.1	Fully Constrained Test Article Model.....	63
10.5.1.2	Test Article in Soil Block Model.....	64
10.5.1.3	Partially Constrained Test Article Model	64
10.5.2	Vehicle Model.....	65
10.5.3	Actual Crash Test Vs. Simulated Crash Tests.....	65
10.5.3.1	Test Article Movement Comparison	65
10.5.3.2	Data Comparison.....	66
10.5.3.3	Visual Comparison.....	68
10.5.4	Conclusions.....	72
10.6	Soil Documentation	73
10.7	Concrete Certification Documentation	87

LIST OF FIGURES

Figure 1-1 Profile of Wyoming TL-4 Bridge Rail (Excerpt from Wyoming DOT TL4 Bridge Railing Sheets) .	3
Figure 1-2 Profile of Caltrans ST-10 Bridge Rail (Excerpt from 2006 California Standard Plan B11-68)	4
Figure 2-1 Excavation	7
Figure 2-2 Rebar for Barrier	8
Figure 2-3 After the First Concrete Placement	8
Figure 2-4 Before the Second Concrete Placement For Curb	9
Figure 2-5 After the Second Concrete Placement.....	9
Figure 2-6 Completed Barrier Construction Front	10
Figure 2-7 Completed Barrier Construction Back	10
Figure 4-1 Test Vehicle Guidance System	14
Figure 4-2 Guidance Arm Release Mechanism	15
Figure 4-3 Vehicle Coordinate Sign Convention	17
Figure 4-4 Event Switch Layout.....	18
Figure 4-5 Camera Locations (Not to Scale).....	20
Figure 5-1 Test 130MASH3P13-03 Impact Location	21
Figure 5-2 Test 130MASH3P13-03 Test Vehicle Pretest 1	22
Figure 5-3 Test 130MASH3P13-03 Test Vehicle Pretest 2	22
Figure 5-4 Test Article After Test 130MASH3P13-03 Looking Downstream.....	24
Figure 5-5 Test Article After Test 130MASH3P13-03 Looking Upstream.....	24
Figure 5-6 Test Article After Test 130MASH3P13-03 Looking Across.....	25
Figure 5-7 Test Article After Test 130MASH3P13-03 Close Up.....	25
Figure 5-8 Locations and Summary of Stringpot Data (Not covered in A2LA Scope of Accreditation)	26
Figure 5-9 Vehicle Riding on Drive Side Front Tire.....	27
Figure 5-10 Front of Vehicle on Its Side After Test 130MASH3P13-03.....	28
Figure 5-11 Top of Vehicle on Its Side After Test 130MASH3P13-03	28
Figure 5-12 Back of Vehicle on Its Side After Test 130MASH3P13-03	29
Figure 5-13 Bottom of Vehicle on Its Side After Test 130MASH3P13-03	29
Figure 5-14 Front Corner of Upright Vehicle After Test 130MASH3P13-03	30
Figure 5-15 Side of Upright Vehicle After Test 130MASH3P13-03	30
Figure 5-16 Driver Side Tire and Hub Assembly.....	31
Figure 5-17 Vehicle Floorboard Pretest 1	31
Figure 5-18 Vehicle Floorboard Pretest 2	32
Figure 5-19 Vehicle Floorboard Post Test	32
Figure 10-1: California Standard Plan for the ST-10 Bridge Rail Sheet 1 of 3	42
Figure 10-2: California Standard Plan for the ST-10 Bridge Rail Sheet 2 of 3	43
Figure 10-3: California Standard Plan for the ST-10 Bridge Rail Sheet 3 of 3	44
Figure 10-4 Trench Foundation Detail	45
Figure 10-5 Foundation Construction Joint Dowel Information	46
Figure 10-6 ALMGR Test Article Weld Details.....	47
Figure 10-7 ALMGR Test Article Tube Details	48
Figure 10-8 ALMGR Test Article Components.....	49
Figure 10-9 Vehicle Longitudinal Accelerometer trace for Test 130MASH3P13-03	56
Figure 10-10 Vehicle Lateral Accelerometer trace for Test 130MASH3P13-03.....	57
Figure 10-11 Vehicle Vertical Accelerometer Trace for Test 130MASH3P13-03	58
Figure 10-12 Vehicle Angular Displacements for Test 130MASH3P13-03.....	59

Figure 10-13 Vehicle Angular Rate of Change for Test 130MASH3P13-03..... 60
Figure 10-14 Acceleration Severity Index for Test 130MASH3P13-03..... 61
Figure 10-15 Fully Constrained Test Article 63
Figure 10-16 Test Article in Soil Block Model..... 64
Figure 10-17 MASH 2270P Test Vehicle 65
Figure 10-18 Before Impact Profile 66
Figure 10-19 Max Dynamic Displacement Profile 66
Figure 10-20 Max Static Displacement Profile 66
Figure 10-21 Visual Comparison of Actual Crash Test to Simulation Crash Tests 69
Figure 10-22 Comparing Crash Test and Simulation Roll Angles 70
Figure 10-23 Comparing Crash Test and Simulation Pitch Angles 71
Figure 10-24 Comparing Crash Test and Simulation Yaw Angles..... 71

LIST OF TABLES

Table 3-1 MASH Test Level 3 Matrix for Longitudinal Barriers	11
Table 3-2 MASH Evaluation Criteria for Longitudinal Barrier	13
Table 4-1 Accelerometer and Gyro Specifications	17
Table 4-2 Typical Camera Type and Locations	19
Table 5-1 Structural Adequacy and Occupant Risk Assessment Summary for Test 130MASH3P13-03	36
Table 10-1 Vehicle Specifications Test 130MASH3P13-3.....	50
Table 10-2 Vehicle Center of Gravity Measurements Test 130MASH3P13-3.....	51
Table 10-3 Occupant Compartment Measurement in Millimeters for Test 130MASH3P13-3.....	52
Table 10-4 Full Scale Test and Test Article in Soil Block Model Movement	66
Table 10-5 Full Scale and FE Model TRAP Results.....	68

1 INTRODUCTION

1.1 Problem

California Department of Transportation (Caltrans) Standard Plan Metal Beam Guardrail (MBGR) requires extensive maintenance after an impact from a run-off-the-roadway vehicle. Along roadways with frequent impacts, there can be numerous sections of damaged MBGR with leaning or broken posts. Until repaired, these damaged sections have diminished effectiveness in redirecting subsequent errant vehicles. Maintenance crews are exposed to traffic hazards when they are on the roadside repairing or replacing damaged sections of guardrail. If lane closures are required, not only are workers and motorist at risk but costs increase for the Caltrans and takes time away from other maintenance tasks. The resulting traffic congestion delays also increases costs to motorists.

In addition to its maintenance issues, many communities and agencies feel that MBGR is not aesthetically pleasing. They feel that it detracts severely from the beautiful natural resources of California's highways along the coast and through parks and forests. In response to demands from local agencies or groups for context sensitive highways, several Caltrans projects have specified acid-etched guardrail. However, acid-etched guardrail is still the same product but with the galvanized shine removed. Many communities and agencies are looking for a guardrail system that is more aesthetically pleasing. Some projects have been delayed because the MBGR does not meet the approval of the local agencies. Project managers are considering other guardrail options to establish context sensitive roadways, but they don't quite fit the need or budget.

Until an alternative to MBGR is created, one that is aesthetic, cost-effective, and low-maintenance, many context-sensitive highway projects will be subject to delays by agencies and commissions whose purpose is to maintain the natural beauty along California highways. If guardrail is used that is not low-maintenance, the traveling public will be subject to traffic delays during repairs. Those repairs will also expose maintenance crews to traffic and the possibility of injury or fatality.

1.2 Objective

The objective of this research is to develop and test new guardrail systems to the American Association of State Highway and Transportation Officials' (AASHTO's) Manual for Assessing Safety Hardware 2009¹ (MASH) Test Level 3 (TL-3) full scale crash testing guidelines. The guardrail system will meet California's need for an aesthetically pleasing guardrail and be able to sustain most vehicular impacts with minimal or no damage. It will have a relatively low life cycle cost, contain a minimum number of parts for maintenance stations to stock, and be easy to repair or replace if required. This research was divided into two tasks. The first task, which is covered in this report, was to test a new concrete footing combined with an aesthetically pleasing bridge rail as the guardrail system. The second task will be to design, fabricate, and test a new guardrail system to meet California's needs as expressed above. The second task will be covered in a future report.

1.3 Background

Guardrails are used to protect motorists from hitting fixed objects that cannot be removed or relocated. It has long been understood that guardrails are only used in locations where striking a guardrail would be less severe than hitting the object it is intended to protect. Current designs of guardrail have been proven effective in redirecting errant vehicles. The guardrail most commonly utilized in California is MBGR or W-Beam Guardrail. The relative flexibility of MBGR has proven problematic because it loses its effectiveness after a severe impact, is expensive to repair and maintain, and the repair and maintenance of MBGR exposes Caltrans' maintenance crews to potential harm from traffic. In addition, local communities and agencies are increasingly demanding that Caltrans build highway projects that include roadside barriers with an aesthetic appearance, which standard W-beam guardrail does not provide. Some highway construction projects are delayed because the barriers do not present an aesthetically acceptable appearance. There are a limited number of National Cooperative Highway Research Program (NCHRP) Report 350² (old crash testing guidelines) and Manual for Assessing Safety Hardware (current crash testing guidelines) Test Level 3 approved aesthetic guardrails, but most are proprietary,

expensive to build and expensive to maintain. This project was established to develop a non-proprietary, low-maintenance, aesthetically acceptable guardrail system.

The ST-10 Bridge Rail used for the test conducted in this report is a modified version of the Wyoming TL-4 Bridge Rail³. The two rails have similar profiles but the Wyoming Rail's lower rail is 3 inches (76 mm) tall and the ST-10 Rail's lower rail is 4 inches (102 mm) tall. The change was made so that the ST-10 parts would be uniform and would require less stock in maintenance yards. Since the difference in profile between the ST-10 and Wyoming Rail is minor, it was deemed that the ST-10 would not need to be crash tested and the change was accepted by the FHWA.

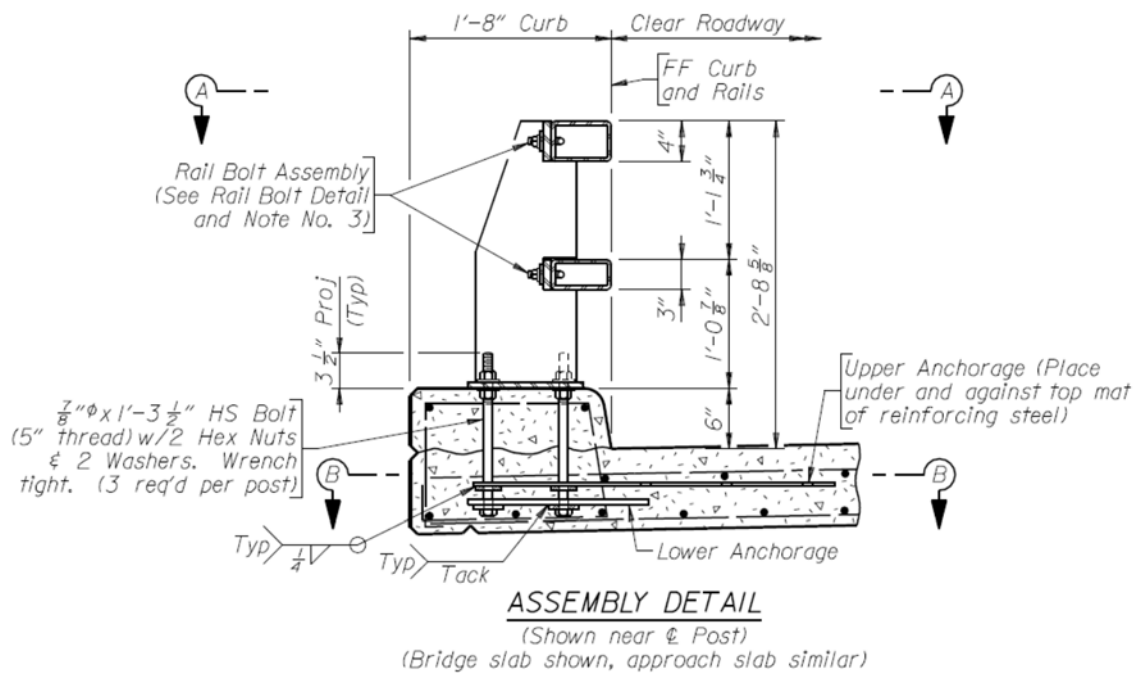

Figure 1-1 Profile of Wyoming TL-4 Bridge Rail (Excerpt from Wyoming DOT TL4 Bridge Railing Sheets)

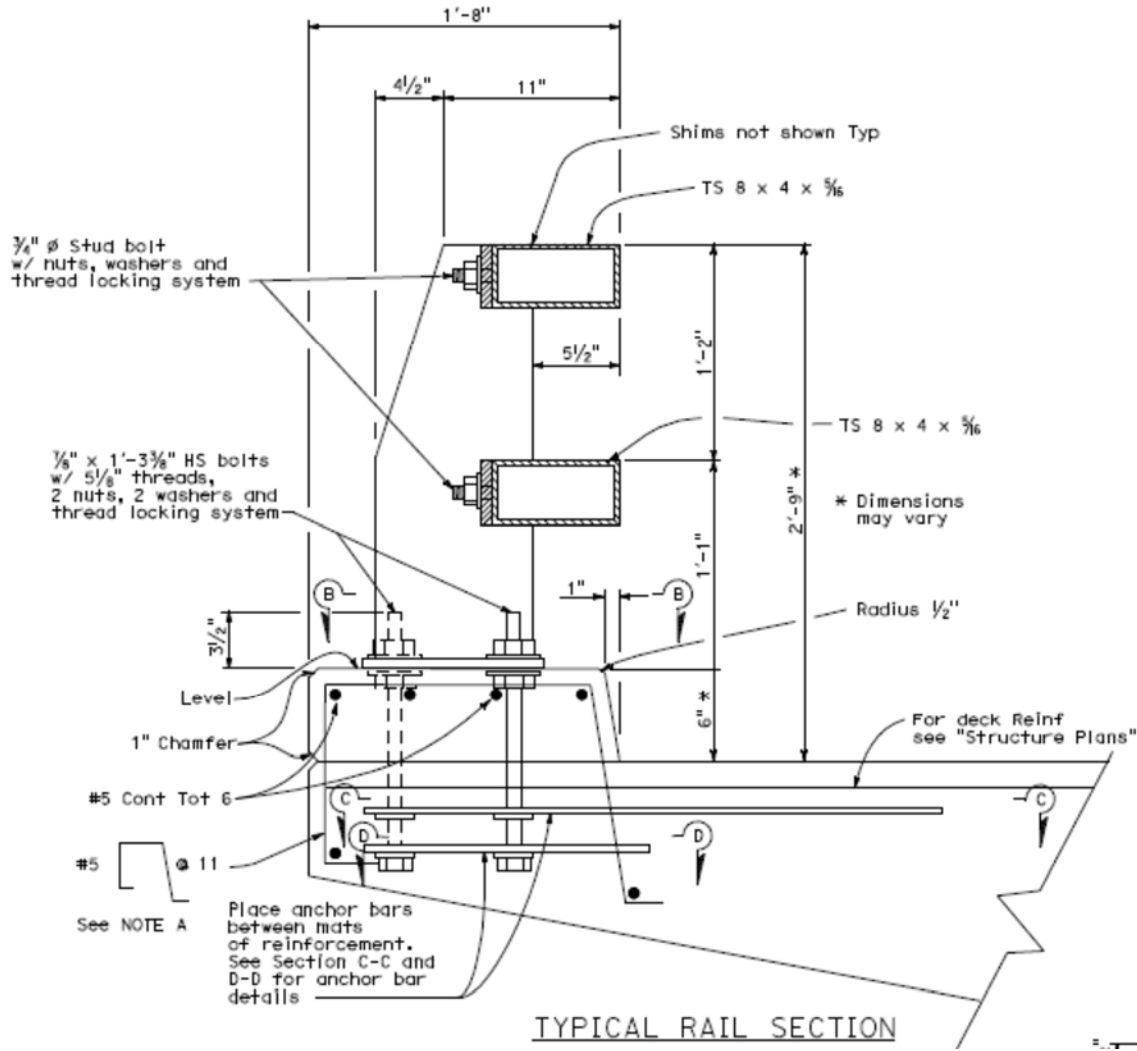

Figure 1-2 Profile of Caltrans ST-10 Bridge Rail (Excerpt from 2006 California Standard Plan B11-68)

1.4 Scope

This report will cover the testing and test results of the first task of an aesthetic bridge rail on a concrete footing. The results will determine if a concrete trench footing provides the structural response needed to accommodate barriers designed and tested for bridge applications. It was decided that the ST-10 bridge rail combined with a 30-inch (762-mm) by 20-inch (508-mm) concrete footing would be the most commonly used system and the most critical. To represent the worst case scenario, several construction modifications were made. The foundation was installed in a weak soil. A 3:1 slope was cut out behind the barrier. A construction cold joint was used between the foundation and the ST-10 curb.

MASH Test Level 3 guidelines require two tests for testing the Length-Of-Need (LON) of longitudinal barriers. Test 3-10 has a passenger car impact the barrier at an angle of 25 degrees and a speed of 62.5 mph (100 km/h). Test 3-11 has a pick-up truck impact the barrier at an angle of 25 degrees and a speed of 62.5 mph (100 km/h). Test 3-11 was deemed to be the most critical and was conducted first. Based on the results of Test 3-11 it was decided that MASH test 3-10 would not need to be conducted.

2 SYSTEM DETAILS

2.1 Test Article

The ST-10 Bridge Rail is a 33-inch (838-mm) high steel barrier that consists of two 8-inch (203-mm) by 4-inch (102-mm) steel rails (designated TS 8x4x5/16 inch) and a 6-inch (152-mm) concrete curb. See Figure 10-1 through Figure 10-3 for Caltrans' 2006 Standard Plans for the ST-10 Bridge Rail. The bridge rail was modified by mounting the rail on a 30-inch (762-mm) by 20-inch (508-mm) concrete trench footing foundation in place of a bridge deck. The length of the test article was 112.6 feet (34.34 m). See Figure 10-4 through Figure 10-8 for details on the test article. The ST-10 Bridge Rail was chosen for this project because it is very rigid and has the least mass of other Caltrans bridge rails. Therefore it would impart the greatest load to the footing.

2.2 Design Modifications during Tests

There were no design modifications during testing.

2.3 Material Specifications

Steel certification documents are available upon request and see Section 10.7 for concrete certification documents. The concrete used in the 30-inch (762-mm) by 20-inch (508-mm) trench footing foundation had an average 28-day strength of 5190 psi (35.8 MPa). The concrete used in the 6-inch (152-mm) curb had an average 28-day strength of 4890 psi (33.7 MPa).

2.4 Soil Specifications

Before the concrete foundation was poured a premium screened topsoil was installed. The soil was compacted to a minimum of 90 percent relative compaction. See Section 10.6 for soil documentation.

2.5 Construction

In an effort to create the worst case scenario, the barrier was installed in a weak soil with a 3:1 slope cut out behind the barrier. The slope starts 3 feet (914 mm) from the back edge of the

barrier's concrete footing and has a depth equal to the depth of the footing which is 30 inches (762 mm). The footing was placed in two parts; the first placement was the footing and the second was the 6-inch (152-mm) curb. These two placements created a cold construction joint between the footing and the curb.

During the installation of the foundation's rebar the back of the barrier's upper edge of the trench footing had some erosion. The erosion was due to the workers having to move around in the trench to assemble the rebar cage for the concrete foundation. The erosion caused the top of the trench to be larger than the bottom by an average of 11 inches (279 mm). This wear on the edges is typical of a field installation for a foundation of this type.



Figure 2-1 Excavation



Figure 2-2 Rebar for Barrier



Figure 2-3 After the First Concrete Placement



Figure 2-4 Before the Second Concrete Placement For Curb



Figure 2-5 After the Second Concrete Placement



Figure 2-6 Completed Barrier Construction Front



Figure 2-7 Completed Barrier Construction Back

3 TEST REQUIREMENT AND EVALUATION CRITERIA

3.1 Crash Test Matrix

The testing conducted in this report followed the guidelines provided in the AASHTO's Manual for Assessing Safety Hardware 2009 (MASH) for Test Level 3 (TL-3). The barrier that was tested is categorized as a rigid longitudinal barrier. All longitudinal barriers are designed to contain, redirect, and shield vehicles from roadside obstacles. The test conducted was designed to test the length-of-need (LON) of a longitudinal barrier. The LON is the part of a longitudinal barrier designed to contain and redirect an errant vehicle.

Test Designation Number 3-11 provides maximum strength tests for Test Levels 1 through 3 and verifies a barrier's performance for impacts involving light trucks and SUVs. Test 3-11 consists of a 5,000-lb (2,270-kg) pickup truck impacting the barrier at a speed and angle of 62 mph (100km/h) and 25 degrees, respectively. Table 3-1 has a summary of the TL-3 longitudinal barrier test matrix conducted for this report.

Table 3-1 MASH Test Level 3 Matrix for Longitudinal Barriers

Test Article	Test Designation No.	Test Vehicle	Impact Conditions			Evaluation Criteria
			Speed		Angle (deg)	
			mph	km/h		
Longitudinal Barrier	3-11	2270P	62	100	25	A,D,F,H,I

3.2 Evaluation Criteria

The evaluation criteria are broken into three dynamic performance evaluation factors and they are: structural adequacy, occupant risk, and post-impact vehicular trajectory. Structural adequacy depends on the intended function of the safety feature. The feature may satisfy structural adequacy by redirecting the vehicle, by stopping the vehicle in a controlled manner, or by permitting the vehicle to break through the device. The structural adequacy criteria refer to the structural requirements associated with the impact itself and not the other structural aspects of the device. The occupant risk criteria evaluate the potential risk to occupants in the impacting

vehicle. It also evaluates, to a lesser extent, the potential risk to other traffic, pedestrians, or workers in construction zones. The post-impact vehicular trajectory is a measure of the potential of the vehicle to result in a secondary collision with other vehicles and/or fixed objects. Table 3-2 has a summary of the evaluation criteria.

Table 3-2 MASH Evaluation Criteria for Longitudinal Barrier

Structural Adequacy	<p>A. Test article should contain and redirect the vehicle or bring the vehicle to a controlled stop; the vehicle should not penetrate, underide, or override the installation although controlled lateral deflection of the test article is acceptable.</p>																					
Occupant Risk	<p>D. Detached element, fragments, or other debris from the test article should not penetrate or show potential for penetrating the occupant compartment, or present undue hazard to other traffic, pedestrians, or personnel in a work zone.</p> <p style="text-align: center;">Deformations of, or intrusions into, the occupant compartment should not exceed limits set forth in Section 5.3 and Appendix E.</p> <p>F. The vehicle should remain upright during and after collision. The maximum roll and pitch angles are not to exceed 75 degrees.</p> <p>H. Occupant impact velocities (OIV) (see Appendix A, Section A5.3 for calculation procedure) should satisfy the following limits:</p> <table border="1" style="width: 100%; border-collapse: collapse; margin-left: 20px;"> <thead> <tr> <th colspan="3" style="text-align: center;">Occupant Impact Velocity Limits, ft/s (m/s)</th> </tr> <tr> <th style="width: 30%;">Component</th> <th style="width: 35%;">Preferred</th> <th style="width: 35%;">Maximum</th> </tr> </thead> <tbody> <tr> <td style="text-align: center;">Longitudinal and Lateral</td> <td style="text-align: center;">30 ft/s (9.1 m/s)</td> <td style="text-align: center;">40 ft/s (12.2 m/s)</td> </tr> <tr> <td style="text-align: center;">Longitudinal</td> <td style="text-align: center;">10 ft/s (3.0 m/s)</td> <td style="text-align: center;">16 ft/s (4.9 m/s)</td> </tr> </tbody> </table> <p>I. The occupant ridedown acceleration (see Appendix A, Section A5.3 for calculation procedure) should satisfy the following limits:</p> <table border="1" style="width: 100%; border-collapse: collapse; margin-left: 20px;"> <thead> <tr> <th colspan="3" style="text-align: center;">Occupant Ridedown Acceleration Limits (G)</th> </tr> <tr> <th style="width: 30%;">Component</th> <th style="width: 35%;">Preferred</th> <th style="width: 35%;">Maximum</th> </tr> </thead> <tbody> <tr> <td style="text-align: center;">Longitudinal and Lateral</td> <td style="text-align: center;">15.0 G</td> <td style="text-align: center;">20.49 G</td> </tr> </tbody> </table>	Occupant Impact Velocity Limits, ft/s (m/s)			Component	Preferred	Maximum	Longitudinal and Lateral	30 ft/s (9.1 m/s)	40 ft/s (12.2 m/s)	Longitudinal	10 ft/s (3.0 m/s)	16 ft/s (4.9 m/s)	Occupant Ridedown Acceleration Limits (G)			Component	Preferred	Maximum	Longitudinal and Lateral	15.0 G	20.49 G
Occupant Impact Velocity Limits, ft/s (m/s)																						
Component	Preferred	Maximum																				
Longitudinal and Lateral	30 ft/s (9.1 m/s)	40 ft/s (12.2 m/s)																				
Longitudinal	10 ft/s (3.0 m/s)	16 ft/s (4.9 m/s)																				
Occupant Ridedown Acceleration Limits (G)																						
Component	Preferred	Maximum																				
Longitudinal and Lateral	15.0 G	20.49 G																				
Vehicular Trajectory	<p>It is preferable that the vehicle be smoothly redirected, and this is typically indicated when the vehicle leaves the barrier within the "exit box". The concept of the exit box is defined by the initial traffic face of the barrier and a line parallel to the initial traffic face of the barrier, at a distance A plus the width of the vehicle plus 16 percent of the length of the vehicle, starting at the final intersection (break) of the wheel track with the initial traffic face of the barrier for a distance of B. All wheel tracks of the vehicle should not cross the parallel line within the distance B</p> <p style="text-align: center;">Distance for Exit Box Criterion</p> <table border="1" style="width: 100%; border-collapse: collapse; margin-left: 20px;"> <thead> <tr> <th style="width: 30%;">Vehicle Type</th> <th style="width: 35%;">A ft (m)</th> <th style="width: 35%;">B ft (m)</th> </tr> </thead> <tbody> <tr> <td style="text-align: center;">Car/Pickup</td> <td style="text-align: center;">$7.2 + V_W + 0.16V_L$ (2.2 + $V_W + 0.16V_L$)</td> <td style="text-align: center;">32.8 (10.0)</td> </tr> <tr> <td style="text-align: center;">Other Vehicles</td> <td style="text-align: center;">$14.4 + V_W + 0.16V_L$ (4.4 + $V_W + 0.16V_L$)</td> <td style="text-align: center;">65.6 (20.0)</td> </tr> </tbody> </table> <p style="margin-left: 20px;">V_W = Vehicle Width V_L = Vehicle Length</p> <div style="text-align: center; margin-top: 10px;"> </div>	Vehicle Type	A ft (m)	B ft (m)	Car/Pickup	$7.2 + V_W + 0.16V_L$ (2.2 + $V_W + 0.16V_L$)	32.8 (10.0)	Other Vehicles	$14.4 + V_W + 0.16V_L$ (4.4 + $V_W + 0.16V_L$)	65.6 (20.0)												
Vehicle Type	A ft (m)	B ft (m)																				
Car/Pickup	$7.2 + V_W + 0.16V_L$ (2.2 + $V_W + 0.16V_L$)	32.8 (10.0)																				
Other Vehicles	$14.4 + V_W + 0.16V_L$ (4.4 + $V_W + 0.16V_L$)	65.6 (20.0)																				

4 TEST CONDITIONS

4.1 Test Facilities

All crash testing was conducted at the Caltrans Dynamic Testing Facility in West Sacramento, California. The test area is a large, flat asphalt concrete surface. There were no obstructions nearby.

4.2 Vehicle Guidance System

A rail guidance system directed the vehicle into the barrier. The guidance rail, anchored at 12.5-ft (3.8-m) intervals along its length, was used to guide a mechanical arm that is attached to the front passenger side wheel of the vehicle (Figure 4-1). A high density polyethylene arm on the front end of the guidance arm was used to trigger the release mechanism on the guidance arm, thereby releasing the vehicle from the guidance system before impact. A 0.375-in (10-mm) nylon rope was used to pull the guidance arm away from the vehicle after the release was triggered.



Figure 4-1 Test Vehicle Guidance System



Figure 4-2 Guidance Arm Release Mechanism

4.3 Data Acquisition System

The test vehicle was modified as follows for the crash test:

- The gas tank on the test vehicle was disconnected from the fuel supply line and drained. A 12-L safety gas tank was installed in the truck bed and connected to the fuel supply line. Gaseous CO₂ was added to the stock fuel tank to purge the gasoline vapors.
- Two rechargeable sealed lead acid 12-volt 12-Ahr batteries were mounted in the vehicle. Each battery powered one of the GMH Engineering Databrick transient data recorders. A rechargeable sealed lead acid 12-volt 40-Ahr battery powered the Electronic Control Box which triggers the data recorders.
- The braking system was comprised of a radio control, a 700-psi (4800-kPa) CO₂ system tank, a solenoid valve, and a regulator and controlled braking after impact and emergency braking if necessary. This system included a pneumatic ram that was attached to the brake pedal. The operating pressure for the ram was adjusted through a pressure regulator during a series of trial runs prior to the actual test. Adjustments were made to ensure the shortest stopping distance without locking up the wheels. When activated, the brakes could be applied in less than 100 milliseconds.

- The remote brakes were controlled via a radio link transmitter. When the brakes were applied by remote control, the ignition was automatically rendered inoperable by removing power to the coil.
- The vehicle was self-propelled and an accelerator switch was located on the passenger side of the vehicle above the rear tire. The switch opened an electric solenoid, which in turn released compressed CO₂ from a reservoir into a pneumatic ram that had been attached to the accelerator pedal. The CO₂ pressure for the accelerator ram was regulated to the same pressure of the remote braking system with a valve to adjust the CO₂ flow rate.
- A speed control device that was connected directly to five of the eight ignition coils was used to regulate the speed of the test vehicle based on the signal from the vehicle's transmission output speed sensor. This device was calibrated prior to the test by conducting a series of trial runs through a speed trap comprised of two tape switches (set at a specific distance apart) and a digital timer.
- A micro-switch was mounted below the front bumper and connected to the ignition system. A trip plate on the ground near the impact point triggered the switch when the vehicle passed over it. The switch opened the ignition circuit and shut off the vehicle's engine prior to impact.

4.3.1 Vehicle Instrumentation and Data Processing

Transducer data were recorded on two separate GMH Engineering Data Brick 2 digital transient data recorders (TDRs) that were mounted in the test vehicle. The transducers mounted in the vehicle included one set of accelerometers and angular rate sensors at the center of gravity (CG) and one set of accelerometers and angular rate sensors 3.1 in (78.7 mm) behind the CG along the X-axis. The TDR data were reduced using a desktop personal computer running DaDisp 2002 version 6.0 NI NK B18 (pre-processing) and Test Risk Assessment Program (TRAP) version 2.3.2 (post-processing). Accelerometer and angular rate sensors specifications are shown in Table 4-1. The coordinate sign convention used throughout this report is the same as described in MASH and is shown in Figure 4-3.

Table 4-1 Accelerometer and Gyro Specifications

Type	Model	Range	Location	Orientation
Endevco Piezoresistive Accelerometer	7264M14-TZ	200 g	Vehicle's CG	Longitudinal (primary)
Endevco Piezoresistive Accelerometer	7264M14-TZ	200 g	Vehicle's CG	Lateral (primary)
Endevco Piezoresistive Accelerometer	7264M14-TZ	200 g	Vehicle's CG	Vertical (primary)
Endevco Piezoresistive Accelerometer	7264M14-200-2	200 g	78.7 mm(3.1 in.) behind the CG along the X-axis	Longitudinal (secondary)
Endevco Piezoresistive Accelerometer	7264M14-200-2	200 g	78.7 mm(3.1 in.) behind the CG along the X-axis	Lateral (secondary)
Endevco Piezoresistive Accelerometer	7264M14-200-2	200 g	78.7 mm(3.1 in.) behind the CG along the X-axis	Vertical (secondary)
DTS Angular Rate Sensor	ARS-1500	1500 deg/sec	Vehicle's CG	Roll (primary)
DTS Angular Rate Sensor	ARS-1500	1500 deg/sec	Vehicle's CG	Pitch (primary)
DTS Angular Rate Sensor	ARS-1500	1500 deg/sec	Vehicle's CG	Yaw (primary)
DTS Angular Rate Sensor	ARS-1500	1500 deg/sec	78.7 mm(3.1 in.) behind the CG along the X-axis	Roll (secondary)
DTS Angular Rate Sensor	ARS-1500	1500 deg/sec	78.7 mm(3.1 in.) behind the CG along the X-axis	Pitch (secondary)
DTS Angular Rate Sensor	ARS-1500	1500 deg/sec	78.7 mm(3.1 in.) behind the CG along the X-axis	Yaw (secondary)

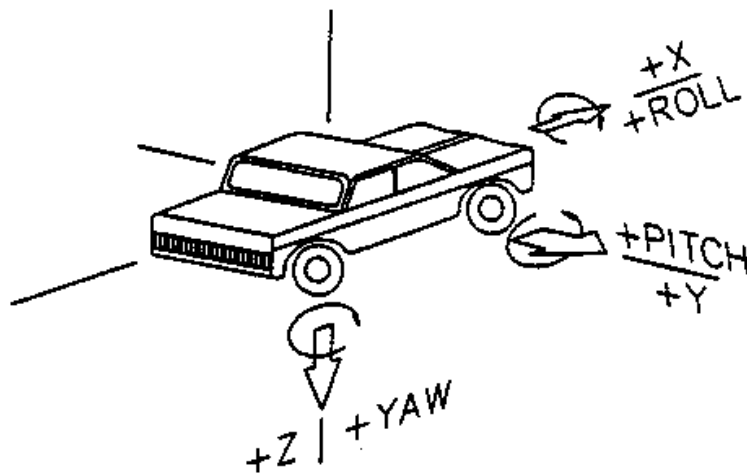

Figure 4-3 Vehicle Coordinate Sign Convention

A rigid stand with three retro-reflective 90° polarizing tape strips was placed on the ground near the test article and alongside the path of the test vehicle. The strips were spaced at carefully measured intervals of 3.28-ft (1.0-m). The test vehicle had an onboard optical sensor that produced sequential impulses or "event blips" as the vehicle passed the reflective tape strips. The event blips were recorded concurrently with the accelerometer signals on the TDR, serving

as "event markers". The impact velocity of the vehicle could be determined from these sensor impulses, the data record time, and the known distance between the tape strips. A pressure sensitive tape switch on the front bumper of the vehicle closed at the instant of impact and triggered two events: 1) an "event marker" was added to the recorded data, and 2) a flashbulb mounted on the top of the vehicle was activated. Two sets of pressure activated tape switches, connected to a speed trap, were placed 13.1 ft (4.0 m) apart just upstream of the test article specifically to establish the informal impact speed of the test vehicle. The layout for all of the pressure sensitive tape switches and reflective tape is shown in Figure 4-4.

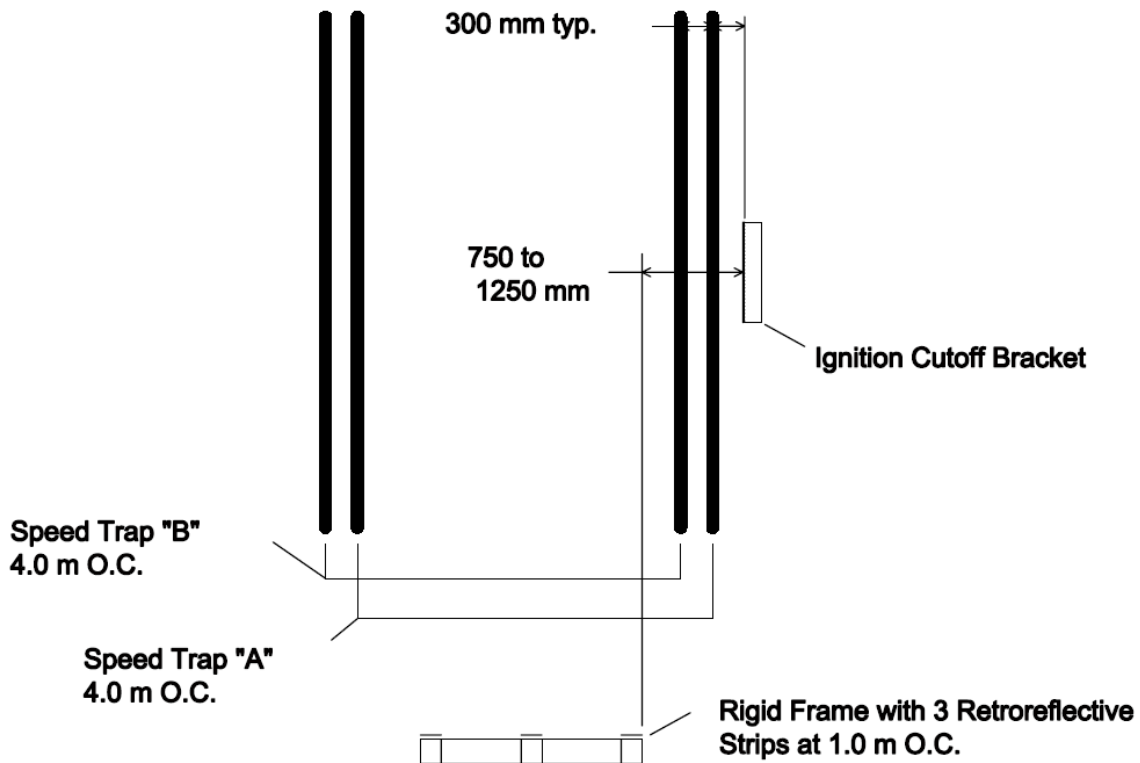

Figure 4-4 Event Switch Layout

The data curves are shown in Figure 10-9 through Figure 10-14 include the accelerometer and angular rate sensor records from the test vehicle. They also show the velocity and displacement curves for the longitudinal and lateral components. These plots are required to calculate the occupant impact velocity defined in MASH. All data were analyzed using TRAP.

4.3.2 Photographic Instrumentation and Data Processing

Several high-speed video cameras recorded the impact during the test. The high-speed video frame rates were set to 500 frames per second. The types of cameras and their locations are shown in Table 4-2 and Figure 4-5. The origin of the coordinates is at the intended point of impact. A manually operated video camera and digital SLR camera were used to pan through the movement of the vehicle during the test. A tape-switch in-line with the vehicle's tire path near the impact area remotely triggered the high-speed digital cameras. Both the vehicle and the barrier were photographed before and after impact with a digital video camera and a digital SLR camera.

Table 4-2 Typical Camera Type and Locations

Camera Location	Camera Type	Figure 4-5 Labels	Coordinates in Feet (m)		
			X*	Y*	Z*
Overhead 1	Phantom Miro 110	C1	-0.19 (-0.06)	-6.75 (-2.06)	31.18 (9.50)
Overhead 2	Phantom Miro 110	C2	30.12 (9.36)	-6.21 (-1.89)	39.80 (12.13)
Across	Phantom v642 Broadcast	C3	6.97 (2.13)	-60.75 (-18.52)	3.60 (1.10)
Downstream	Phantom v642 Broadcast	C4	205.70 (62.69)	-1.35 (-0.41)	4.55 (1.39)
Upstream	Phantom v642 Broadcast	C5	-175.65 (-53.54)	0.90 (0.27)	5.07 (1.54)
Note: *X, Y, and Z distances are relative to the impact point.					

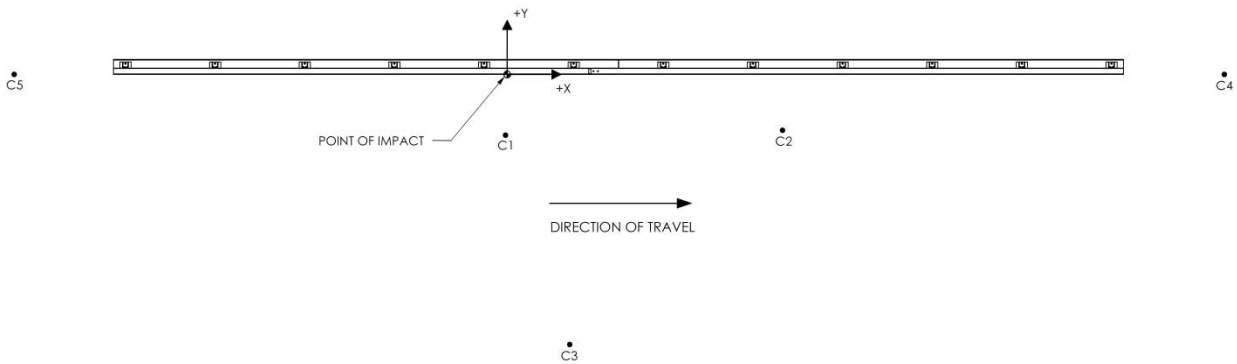

Figure 4-5 Camera Locations (Not to Scale)

The following are the pretest procedures that were required to enable video data reduction to be performed using the video analysis software Phantom Camera Control Application (PCC) from Vision Research:

1. Quad targets were attached to the top and sides of the test vehicle. The targets were located on the vehicle at intervals of 1.64-ft (0.5-m) and 3.28-ft (1.0-m). The targets established scale factors.
2. Flashbulbs, mounted on the test vehicle, were electronically triggered to establish initial vehicle-to-barrier contact and the time of the application of the vehicle brakes. The flashbulbs begin to glow immediately upon activation, but have a delay of several milliseconds before the light reaches full intensity. Due to an electrical problem, the flashbulbs did not activate.
3. High-speed digital video cameras were all time-coded through the use of a portable computer and were triggered as the test vehicle passed over a tape switch located on the vehicle path upstream of impact.

5 CRASH TEST NUMBER 130MASH3P13-03

5.1 Test Designation and Actual Impact Conditions – Test 130MASH3P13-03

The test in this report was a MASH Test Level 3 test and has the test designation of 3-11, which consists of a 5000-lbs (2270-kg) pickup truck impacting a longitudinal barrier test article at a speed of 62.0 mph (100.0 km/h) and an angle of 25 degrees. The target impact was 5.5 ft (1.67 m) upstream of Post 6, see Figure 5-1. The test vehicle used in the test had a test inertial weight of 5017.3 lbs (2275.8 kg) and the actual impact speed and angle were 62.0 mph (99.8 km/h) and 24.7 degrees, respectively. The actual impact point was 5.6 ft (1.71 m) upstream of Post 6. The impact severity was 112.4 kip-ft (152.4 kJ), which meets the ≥ 106 kip-ft (144 kJ) criteria given in MASH.

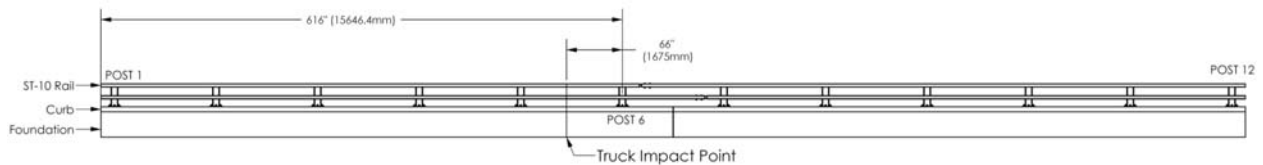

Figure 5-1 Test 130MASH3P13-03 Impact Location

5.2 Test Vehicle – Test 130MASH3P13-03

The test vehicle was a 2006 Dodge Ram 1500 Quad Cab pickup truck. The vehicle was in good condition and complied with MASH criteria. The test inertial weight of the vehicle was 5017.3 lbs (2275.8 kg). Dimensions and information on the test vehicle are reported in Section 10.2. The vehicle was self-powered. The engine was modified to include a speed-control device, which limited acceleration once the impact speed had been reached. To meet the 28-inch (710-mm) minimum vertical center of gravity height, 104 lbs (47.3 kg) of ballast was added to the front center of the truck bed. Additional modifications included a remote braking system, a modification to the front right wheel for the guidance system, and the addition of various sensors and electronics. A detailed description of the test vehicle equipment and guidance system is contained in Section 4.2 and 4.3.



Figure 5-2 Test 130MASH3P13-03 Test Vehicle Pretest 1



Figure 5-3 Test 130MASH3P13-03 Test Vehicle Pretest 2

5.3 Weather Conditions – Test 130MASH3P13-03

The test was conducted on October 16, 2013 at 12:45pm. The day was sunny and clear with a temperature of 75°F. There was a slight breeze from the south with a speed of 3 mph (4.8 km/h). The vehicle was traveling in the southern direction.

5.4 Soil Conditions - Test 130MASH3P13-03

The soil around the foundation was a screened top soil that was compacted to 90% relative compaction. The soil was dry and it had been more than two weeks since it had last rained. See Section 10.5 for more information on the soil.

5.5 Test Description – Test 130MASH3P13-03

The test vehicle impacted the test article 5.5 ft (1.67 m) downstream of Post 6 at a speed of 62.0 mph (99.8 km/h) and an angle of 24.7 degrees. At approximately 0.024 s after impact the vehicle began to be redirected by the barrier and the top left front corner of the vehicle overrode the top of the barrier. At 0.104 s the vehicle was being redirected and the top of the driver side door had bent away from the vehicle. The vehicle was parallel with the test article at 0.166 s. The left front tire broke off and began to curl under the vehicle at 0.240 s and was completely under the left front corner of the vehicle at 0.366 s. At 0.478 s the vehicle started to roll onto the driver side of the vehicle. At 0.560 s the vehicle was no longer in contact with the barrier and had an exit speed of 56.5 mph (90.9 km/h) and an exit angle of 7.7 degrees. The vehicle rolled onto its side at 1.350 s and continued to slide down the roadway on its side until it came to rest 256.9 ft (78.3 m) from the point of impact. See Section 10.3 for a visual sequence of the crash test.

5.6 Test Article Damage - Test 130MASH3P13-03

There was only cosmetic damage to the test article. The only maintenance that might be done is to use paint to cover over the marks left by the vehicle's tires.



Figure 5-4 Test Article After Test 130MASH3P13-03 Looking Downstream



Figure 5-5 Test Article After Test 130MASH3P13-03 Looking Upstream



Figure 5-6 Test Article After Test 130AMSH3P13-03 Looking Across



Figure 5-7 Test Article After Test 130MASH3P13-03 Close Up

5.6.1 Stringpot Measurement of Barrier Movement*

Eight string potentiometers (stringpots) were used on the top rail and on the back of the curb in the area of the impact to record the barrier's lateral movement, see Figure 5-8 for location and summary details. The stringpots on the curb recorded a maximum dynamic deflection of 0.13 inches (3 mm) and maximum static displacement of 0.04 inches (1 mm). All but one of the stringpots on the top rail were hit by debris and were not able to provide dynamic deflection measurements. The one top rail stringpot that was not hit by debris was located at the point of impact and recorded a maximum of 0.62 inches (16 mm) of dynamic deflection. Although most of the top rail stringpots were not able to provide dynamic deflection measurements they were able to provide static displacement measurements. The maximum static displacement of the top rail was measured as 0.42 inches (11 mm).

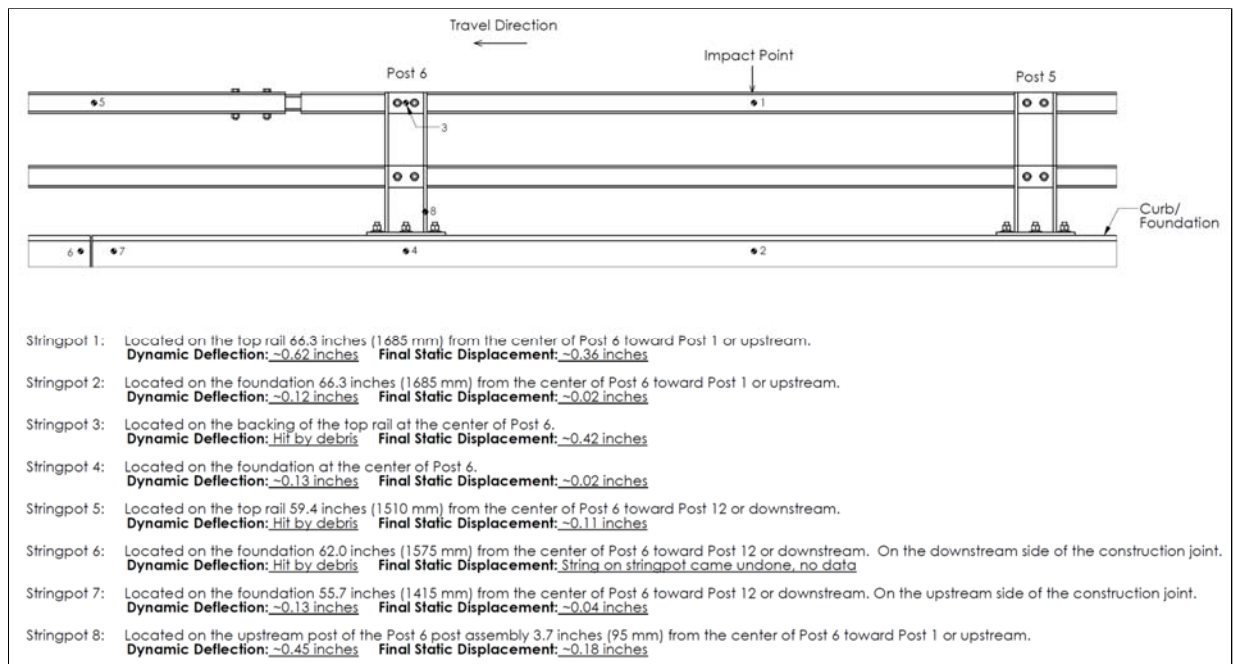

Figure 5-8 Locations and Summary of Stringpot Data*

* Use of stringpots is outside the scope of RSRG's A2LA accreditation #3046.01

5.7 Vehicle Damage – Test 130MASH3P13-03

Damage to the vehicle is shown in Figure 5-10 through Figure 5-16. Impact with the test article caused the driver side front tire and hub assembly to break off of the vehicle. The left side of the vehicle sustained the majority of the damage, with the left front corner of the vehicle being pushed back into the vehicle from the impact with the barrier. The left side of the vehicle was damaged as the vehicle was redirected parallel to the barrier and the vehicle's momentum pushed the vehicle into the barrier. Additional scraping damage to the paint and door handles on the vehicle's left side was caused by the vehicle rolling onto its side. The driver side window was shattered when the side mirror broke off during the vehicle's roll onto its side; the shattered window was not caused by the impact with the barrier.

Figure 5-17 through Figure 5-19 shows the floorboard of the vehicle before and after impact with the test article. Table 10-3 shows the measurements of the occupant compartment before and after impact with the test article. The maximum deformation measured in the occupant compartment was 2.8 inches (70 mm) in the longitudinal direction on the wall of the floorboard near the engine compartment firewall, see Figure 5-19.



Figure 5-9 Vehicle Riding on Drive Side Front Tire



Figure 5-10 Front of Vehicle on Its Side After Test 130MASH3P13-03



Figure 5-11 Top of Vehicle on Its Side After Test 130MASH3P13-03



Figure 5-12 Back of Vehicle on Its Side After Test 130MASH3P13-03



Figure 5-13 Bottom of Vehicle on Its Side After Test 130MASH3P13-03



Figure 5-14 Front Corner of Upright Vehicle After Test 130MASH3P13-03



Figure 5-15 Side of Upright Vehicle After Test 130MASH3P13-03



Figure 5-16 Driver Side Tire and Hub Assembly



Figure 5-17 Vehicle Floorboard Pretest 1

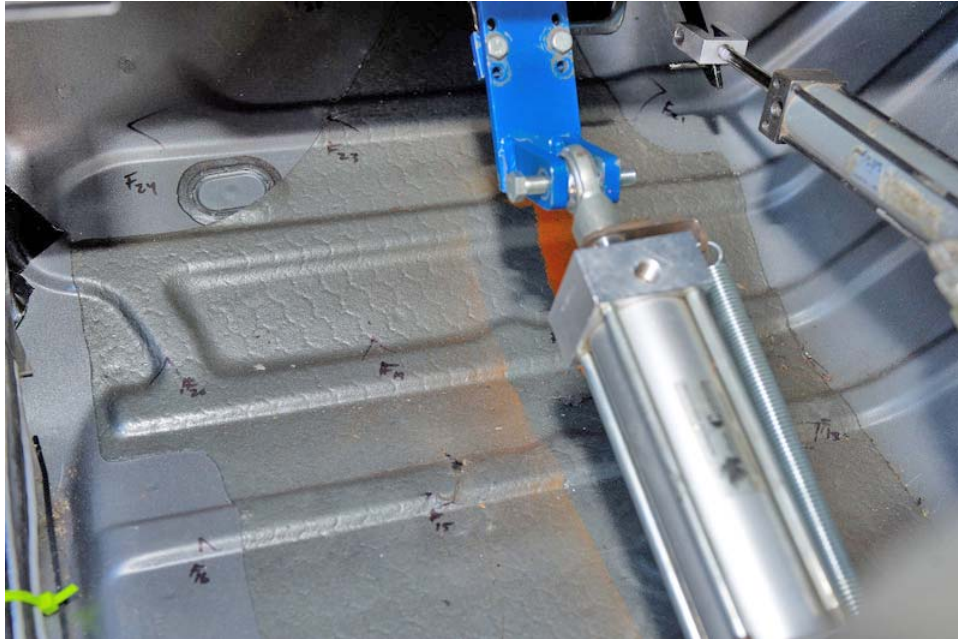

Figure 5-18 Vehicle Floorboard Pretest 2

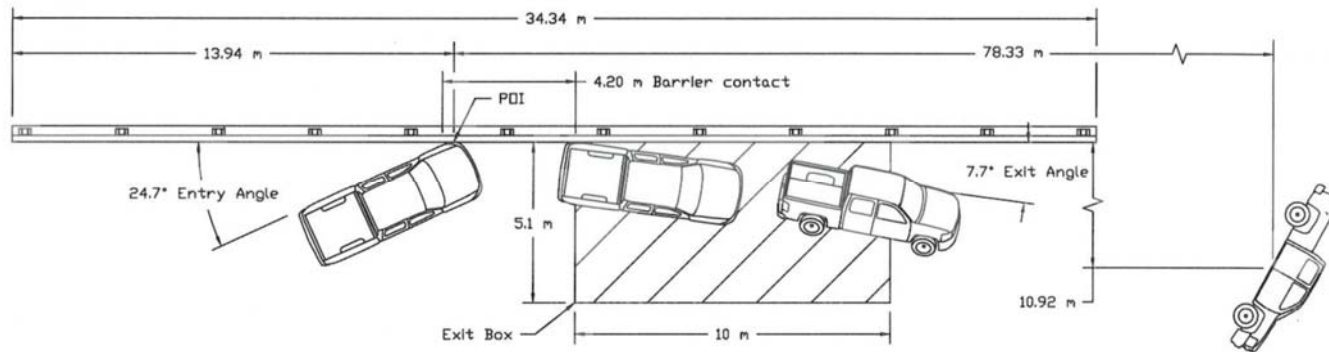

Figure 5-19 Vehicle Floorboard Post Test

5.8 Occupant Risk Factors – Test 130MASH3P13-03

Data from the accelerometers and angular rate sensors located at the center of the gravity were analyzed to evaluate the occupant risk. In the longitudinal direction, the occupant impact velocity was 13.8 ft/s (4.2 m/s) at 0.088s, the ridedown acceleration was 4.8 G's between 0.200 s and 0.100 s, and the maximum 0.050-s average acceleration was -6.5 G's between 0.034 and 0.084 s. In the lateral direction, the occupant impact velocity was -28.2 ft/s (-8.6 m/s) at 0.88 s, the ridedown acceleration was 13.8 G's between 0.195 s and 0.205 s, and the maximum 0.050-s average acceleration was 15.5 G's between 0.031 s and 0.080 s. The maximum 0.050-s average acceleration was -1.8 G's between 0.010 s and 0.060 s in the vertical direction. The Theoretical Head Impact Vehicle (THIV) was 21.3 mph (34.3 km/h) or 31.2 ft/s (9.5 m/s) at 0.086 s; the Post-Impact Head Deceleration (PHD) was 14.3 G's between 0.198 s and 0.208 s; and the Acceleration Severity Index (ASI) was 1.94 between 0.054 s and 0.104 s. See Section 5.9 for the data summary sheet on test 130MASH3P13-03. The vehicle's maximum roll was 118.5 degree at 1.710 s, pitch was -32.1 degrees at 1.446 s, and Yaw was 28.9 degrees at 0.340 s. Vehicle angular displacements and accelerations versus time trace are in Section 10.4, Figure 10-9 through Figure 10-14. Ultimately test 130MASH3P13-03 fails MASH's occupant risk criteria due to the vehicle rolling onto its side.

5.9 Data Summary Sheet – Test 130MASH3P13-03



General Information:

Test Agency: Roadside Safety Research Group
 Test Number: 130MASH3P13-03
 Test Standard No.: MASH Test 3-11
 Date: 10/16/2013

Test Article:

Type: ST-10 Bridge Rail on a 30 inch (762mm) by 20 inch (508mm) trench footing foundation with a 6 inch (152mm) curb and a 3:1 slope 36 inches (914mm) behind the article.
 Installation Length: 112.7 ft (34.3 m)
 Key Elements: Combination of bridge rail and concrete foundation, slope behind test article, cold joint between curb and foundation.

Test Vehicle:

Type/Description: 2270P
 Make and Model: 2006 Dodge Ram 1500 Quad Cab
 Curb: 4923.4 lbs (2233.2 kg)
 Test Inertial: 5017.3 lbs (2275.8 kg)

Impact Conditions:

Speed: 62.0 mph (99.8 km/h)
 Angle: 24.7 degrees
 Location/Orientation: 5.5 ft (1.67 m) upstream of Post 6
 Impact Severity 152.4 kJ (112.4 kip-ft)

Exit Conditions:

Speed: 56.5 mph (90.9 km/h)
 Angle: 7.7 degrees

Post-Impact Trajectory:

Vehicle Stability: Rolled onto drive side
 Stopping Distance: 256.9 ft (78.3 mm)

Occupant Risk:

Impact Velocity:
 Longitudinal OIV: 13.8 ft/s (4.2 m/s)
 Lateral OIV: -28.2 ft/s (-8.6 m/s)
 Ridedown Accelerations:
 Longitudinal RA: 4.8 g's
 Lateral RA: 13.8 g's
 THIV 21.3 mph (34.3 km/h)
 PHD 14.3 g's
 ASI 1.94

Ridedown Accelerations (Cont.):

Max. 0.050-s Average
 Longitudinal -6.5 g's
 Lateral 15.5 g's
 Vertical -1.8 g's

Vehicle Stability:

Max. Roll Angle 118.5 angle
 Max. Pitch Angle -32.1 angle
 Max. Yaw Angle 28.9 angle

Test Article Damage: Superficial/Cosmetic

Test Article Deflections*:

Foundation:
 Permanent Set: ~0.03 inches (1mm)
 Dynamic: ~0.13 inches (3mm)
 Top of Bridge Rail:
 Permanent Set: ~0.42 inches (11mm)
 Dynamic: Sensors hit by debris

Vehicle Damage:

VDS^{4, 5}: 11LFQ-6, LD-5
 CDC⁶: 11LDEO2
 Max. Occupant Compartment Deformation: -2.8 inches (-70 mm)

* Use of stringpots is outside the scope of RSRG's A2LA accreditation #3046.01

5.10 Assessment of Test Results for Test 130MASH3P13-03

MASH stipulates that crash test performance is assessed to three evaluation factors: 1) Structural Adequacy, 2) Occupant Risk, and 3) Vehicle Trajectory.

5.10.1 Structural Adequacy for Test 130MASH3P13-03

The structural adequacy of the test article was acceptable. Test vehicle 130MASH3P13-03 was contained and redirected, while the test article was not penetrated or overridden. An assessment summary of the structural adequacy is shown in Table 5-1.

5.10.2 Occupant Risk for Test 130MASH3P13-03

The occupant risk for this test is unacceptable. The test vehicle did not remain upright after the collision and came to rest on its side. Table 5-1 has a summary of the occupant risk assessment.

5.10.3 Vehicle Trajectory for Test 130MASH3P13-03

The vehicle trajectory was acceptable. The exit angle of the vehicle was 7.7 degrees. See Table 5-1 for a summary of the vehicle trajectory and a description of the vehicle trajectory "exit box". The dimensions of the "exit box" are A equals 16.8 ft (5.1 m) and B equals 32.8 ft (10.0 m). The wheel track of the test vehicle did not cross the parallel line within the distance B.

Table 5-1 Structural Adequacy and Occupant Risk Assessment Summary for Test 130MASH3P13-03

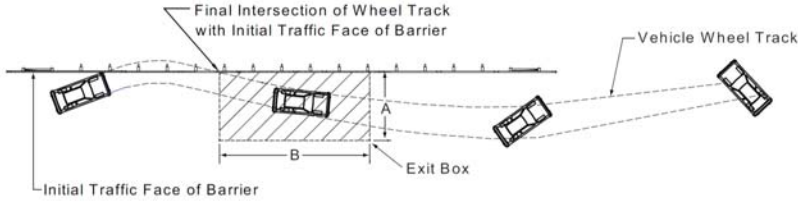
Structural Adequacy	A. Test article should contain and redirect the vehicle or bring the vehicle to a controlled stop; the vehicle should not penetrate, underride, or override the installation although controlled lateral deflection of the test article is acceptable.	Pass									
Occupant Risk	D. Detached element, fragments, or other debris from the test article should not penetrate or show potential for penetrating the occupant compartment, or present undue hazard to other traffic, pedestrians, or personnel in a work zone. Deformations of, or intrusions into, the occupant compartment should not exceed limits set forth in Section 5.3 and Appendix E.	Pass									
	F. The vehicle should remain upright during and after collision. The maximum roll and pitch angles are not to exceed 75 degrees.	Fail									
	H. Occupant impact velocities (OIV) (see Appendix A, Section A5.3 for calculation procedure) should satisfy the following limits:	Pass									
	Occupant Impact Velocity Limits, ft/s (m/s)										
	<table border="1" style="width: 100%; border-collapse: collapse;"> <thead> <tr> <th style="width: 70%;">Component</th> <th style="width: 15%;">Preferred</th> <th style="width: 15%;">Maximum</th> </tr> </thead> <tbody> <tr> <td style="text-align: center;">Longitudinal and Lateral</td> <td style="text-align: center;">30 ft/s (9.1 m/s)</td> <td style="text-align: center;">40 ft/s (12.2 m/s)</td> </tr> </tbody> </table>		Component	Preferred	Maximum	Longitudinal and Lateral	30 ft/s (9.1 m/s)	40 ft/s (12.2 m/s)			
Component	Preferred	Maximum									
Longitudinal and Lateral	30 ft/s (9.1 m/s)	40 ft/s (12.2 m/s)									
<table border="1" style="width: 100%; border-collapse: collapse;"> <thead> <tr> <th style="width: 70%;">Component</th> <th style="width: 15%;">Preferred</th> <th style="width: 15%;">Maximum</th> </tr> </thead> <tbody> <tr> <td style="text-align: center;">Longitudinal</td> <td style="text-align: center;">10 ft/s (3.0 m/s)</td> <td style="text-align: center;">16 ft/s (4.9 m/s)</td> </tr> </tbody> </table>	Component	Preferred	Maximum	Longitudinal	10 ft/s (3.0 m/s)	16 ft/s (4.9 m/s)					
Component	Preferred	Maximum									
Longitudinal	10 ft/s (3.0 m/s)	16 ft/s (4.9 m/s)									
I. The occupant ridedown acceleration (see Appendix A, Section A5.3 for calculation procedure) should satisfy the following limits:	Pass										
Occupant Ridedown Acceleration Limits (G)											
<table border="1" style="width: 100%; border-collapse: collapse;"> <thead> <tr> <th style="width: 70%;">Component</th> <th style="width: 15%;">Preferred</th> <th style="width: 15%;">Maximum</th> </tr> </thead> <tbody> <tr> <td style="text-align: center;">Longitudinal and Lateral</td> <td style="text-align: center;">15.0 G</td> <td style="text-align: center;">20.49 G</td> </tr> </tbody> </table>		Component	Preferred	Maximum	Longitudinal and Lateral	15.0 G	20.49 G				
Component	Preferred	Maximum									
Longitudinal and Lateral	15.0 G	20.49 G									
Vehicular Trajectory	<p>It is preferable that the vehicle be smoothly redirected, and this is typically indicated when the vehicle leaves the barrier within the "exit box". The concept of the exit box is defined by the initial traffic face of the barrier and a line parallel to the initial traffic face of the barrier, at a distance A plus the width of the vehicle plus 16 percent of the length of the vehicle, starting at the final intersection (break) of the wheel track with the initial traffic face of the barrier for a distance of B. All wheel tracks of the vehicle should not cross the parallel line within the distance B</p> <p><u>For Test 130MASH3P13-03: A = 16.8ft (5.1m) and B = 32.8ft (10.0m)</u></p> <p style="text-align: center;">Distance for Exit Box Criterion</p> <table border="1" style="width: 100%; border-collapse: collapse; margin-left: auto; margin-right: auto;"> <thead> <tr> <th style="width: 30%;">Vehicle Type</th> <th style="width: 35%;">A ft (m)</th> <th style="width: 35%;">B ft (m)</th> </tr> </thead> <tbody> <tr> <td>Car/Pickup</td> <td style="text-align: center;">$7.2 + V_W + 0.16V_L$ (2.2 + $V_W + 0.16V_L$)</td> <td style="text-align: center;">32.8 (10.0)</td> </tr> <tr> <td>Other Vehicles</td> <td style="text-align: center;">$14.4 + V_W + 0.16V_L$ (4.4 + $V_W + 0.16V_L$)</td> <td style="text-align: center;">65.6 (20.0)</td> </tr> </tbody> </table> <p style="margin-left: 40px;">V_W = Vehicle Width V_L = Vehicle Length</p> <div style="text-align: center; margin-top: 20px;">  <p>The diagram illustrates the 'Exit Box' concept. It shows a vehicle's path starting from the 'Initial Traffic Face of Barrier' on the left. The vehicle's path curves to the right, crossing the barrier. The 'Final Intersection of Wheel Track with Initial Traffic Face of Barrier' is marked. From this point, a distance 'B' is measured along the initial traffic face to the start of the 'Exit Box'. The 'Exit Box' is a shaded rectangular area extending a distance 'A' from the start of the box. The vehicle's path is shown crossing the barrier and ending within the 'Exit Box'. A dashed line represents the 'Vehicle Wheel Track'.</p> </div>	Vehicle Type	A ft (m)	B ft (m)	Car/Pickup	$7.2 + V_W + 0.16V_L$ (2.2 + $V_W + 0.16V_L$)	32.8 (10.0)	Other Vehicles	$14.4 + V_W + 0.16V_L$ (4.4 + $V_W + 0.16V_L$)	65.6 (20.0)	Pass
Vehicle Type	A ft (m)	B ft (m)									
Car/Pickup	$7.2 + V_W + 0.16V_L$ (2.2 + $V_W + 0.16V_L$)	32.8 (10.0)									
Other Vehicles	$14.4 + V_W + 0.16V_L$ (4.4 + $V_W + 0.16V_L$)	65.6 (20.0)									

5.11 Discussion

Due to the results of test 130MASH3P13-03, no further testing was conducted. The ST-10 Bridge Rail is still acceptable under NCHRP Report 350 but it did not pass under MASH. Even though the ST-10 was placed on a concrete footing instead of on a bridge deck, the fact that the deflection in the footing was very small indicates that the footing had a minimal effect on the way the vehicle interacted with the barrier. In the Wyoming Test Level 4 Bridge Railing report the NCHRP Report 350 Test 3-11 resulted in the truck having a maximum roll of 12.6 degrees; test 130MASH3P13-03 resulted in a maximum roll of 118.5 degrees. Per FHWA's Implementation plan for MASH, when hardware that has passed under Report 350 guidelines but fails under MASH, the AASHTO Technical Committee on Roadside Safety and FHWA will jointly review the hardware to determine a course of action.

6 CONCLUSIONS

Based on the testing of Caltrans' ST-10 bridge rail mounted on a 30-inch (762-mm) by 20-inch (508-mm) concrete trench footing foundation the following conclusions can be drawn:

1. The combination of a 33-inch (838-mm) high bridge rail and concrete foundation successfully redirected a Quad Cab Dodge Ram 1500 pickup truck impacting under MASH's Test Level 3 guidelines.
2. The test article failed the Occupant Risk Criteria (F) due to the high degree of roll after losing contact with the barrier.
3. The vehicle's trajectory from the test article was acceptable.
4. Even with the high vehicle roll, there was minimal deformation to the occupant compartment.
5. Damage to the test article was cosmetic only and would not require immediate repair.
6. The concrete foundation functioned as designed with minimal movement.
7. Although the ST-10 is an acceptable barrier under NCHRP Report 350, it failed under MASH. Per FHWA's Implementation plan for MASH, when hardware that has passed under Report 350 guidelines but fails under MASH, the AASHTO Technical Committee on Roadside Safety and FHWA will jointly review the hardware to determine a course of action.
8. The use of the concrete trench foundation for barriers designed for bridge deck applications is acceptable within the size and site conditions described in this report.

7 RECOMMENDATIONS

The purpose of the test described in this report was to evaluate the structural response of a bridge rail installed on a trench footing to a MASH Test Level 3 impact. Although the combination of ST-10 bridge rail and concrete foundation failed MASH's evaluation criteria (F) for occupant risk, the trench footing still functioned as intended. Therefore, this trench footing is recommended for use with any bridge rail designs that have met either NCHRP Report 350 or MASH Test Level 3 or 4 criteria. The rail/footing combinations should only be considered for use on California's roadways as TL-3 guardrail.

8 IMPLEMENTATION

The California Department of Transportation's Division of Traffic Operations, Office of Engineering Services, and/or Division of Design will be responsible to collaborate, and develop policies and details for mounting bridge rail to the concrete trench footing that was tested in this report. Technical support will be provided by the Division of Research, Innovation, and System Information.

9 REFERENCES

1. AASHTO. *Manual for Assessing Safety Hardware 2009*. American Association of State Highway and Transportation Officials, Washington, DC, 2010
2. Ross, Jr., H.E., Sicking, D.L., Zimmer, R.A. and Michie, J.D. *Recommended Procedures for the Safety Performance Evaluation of Highway Features*. National Cooperative Highway Research Program *Report 350*, Transportation Research Board, National Research Record, Washington, DC, 1993.
3. Mak, K.K., Menges, W.L., and Bullard, Jr., D.L. *Wyoming Test Level 4 Bridge Railing*. Texas Transportation Institute, College Station, Texas, 1996.
4. NSC. *Vehicle Damage Scale for Traffic Accident Investigators*. National Safety Council, 444 Michigan Avenue, Chicago, Illinois, 1984.
5. TxDOT. *Vehicle Damage Guide for Traffic Crash Investigators*. Texas Department of Transportation, 2008.
6. SAE, *Collision Deformation Classification*. SAE J224 Mar80. Recommended Practices, Society of Automotive Engineers, New York, New York, 1980.

10 APPENDIXES

10.1 Details of Test Article

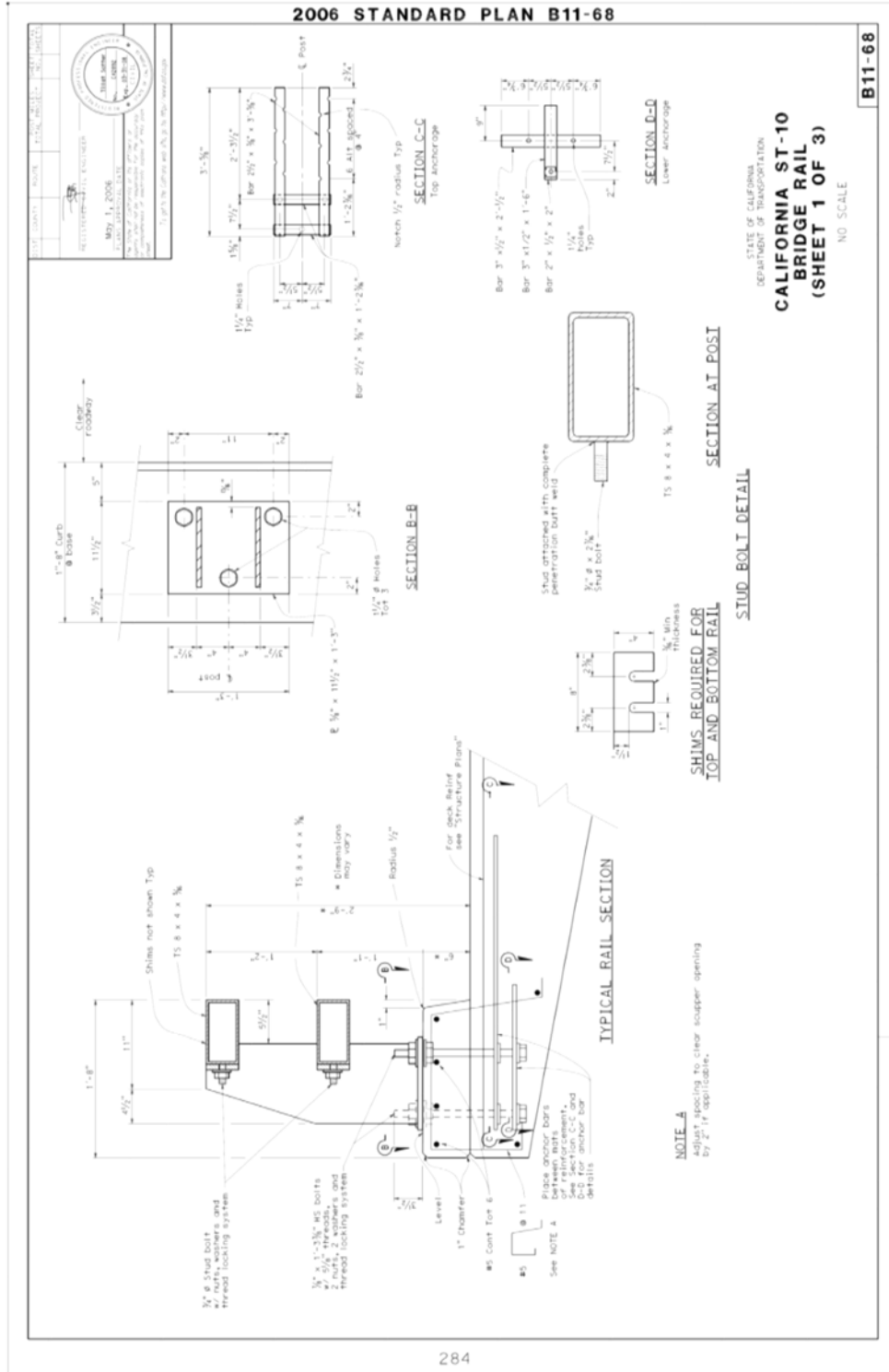

Figure 10-1: California Standard Plan for the ST-10 Bridge Rail Sheet 1 of 3

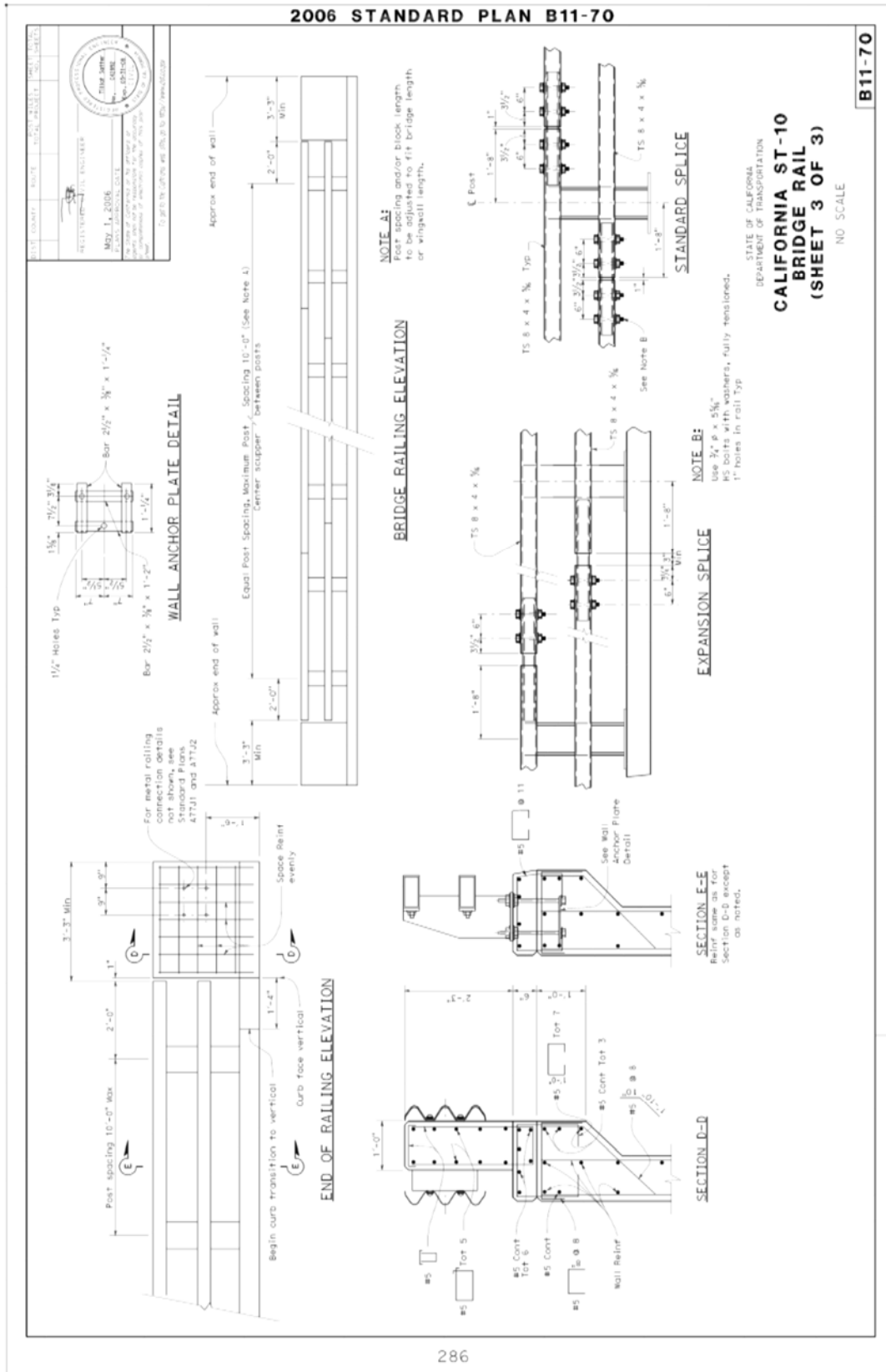

Figure 10-3: California Standard Plan for the ST-10 Bridge Rail Sheet 3 of 3

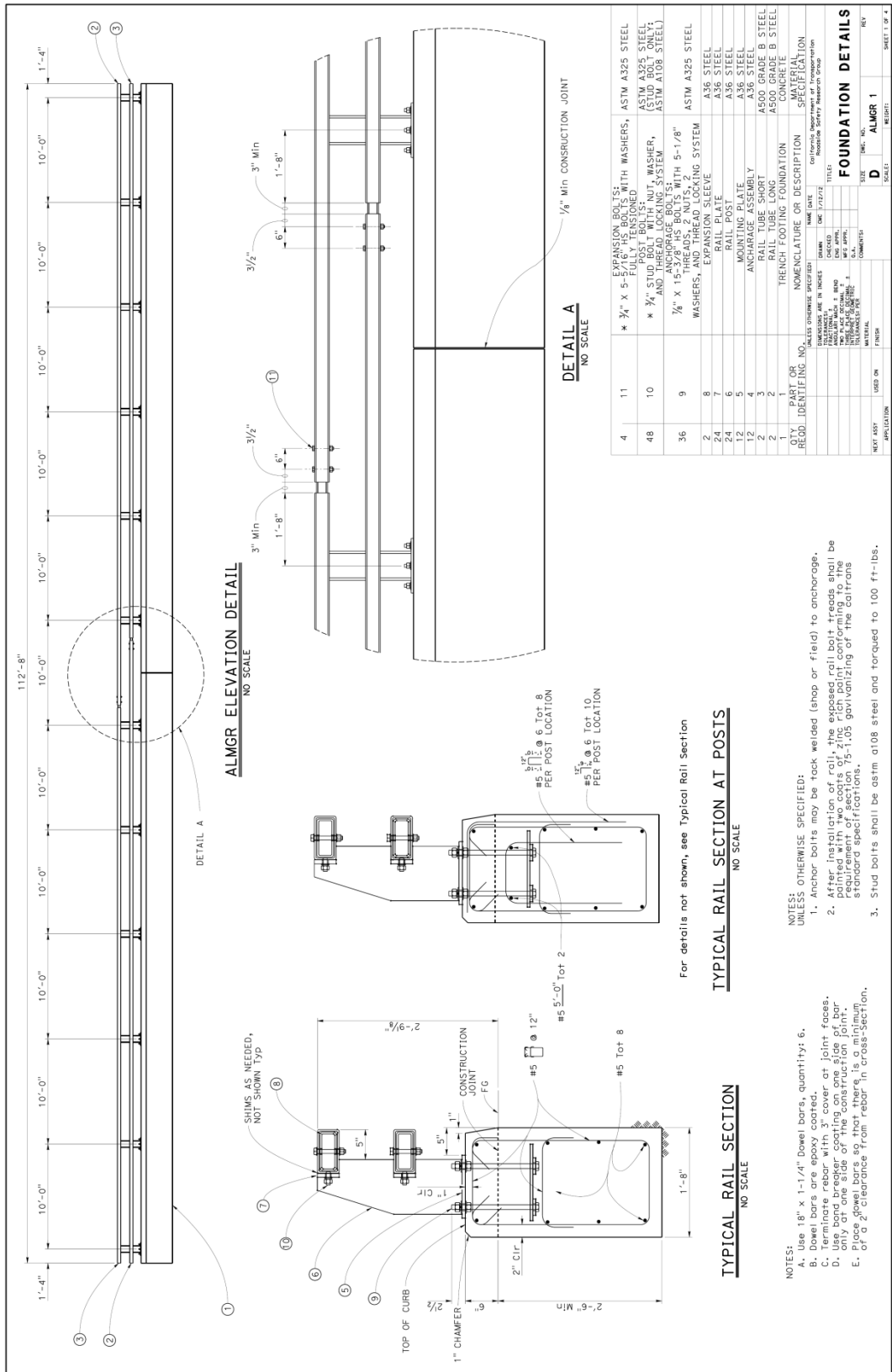

Figure 10-4 Trench Foundation Detail

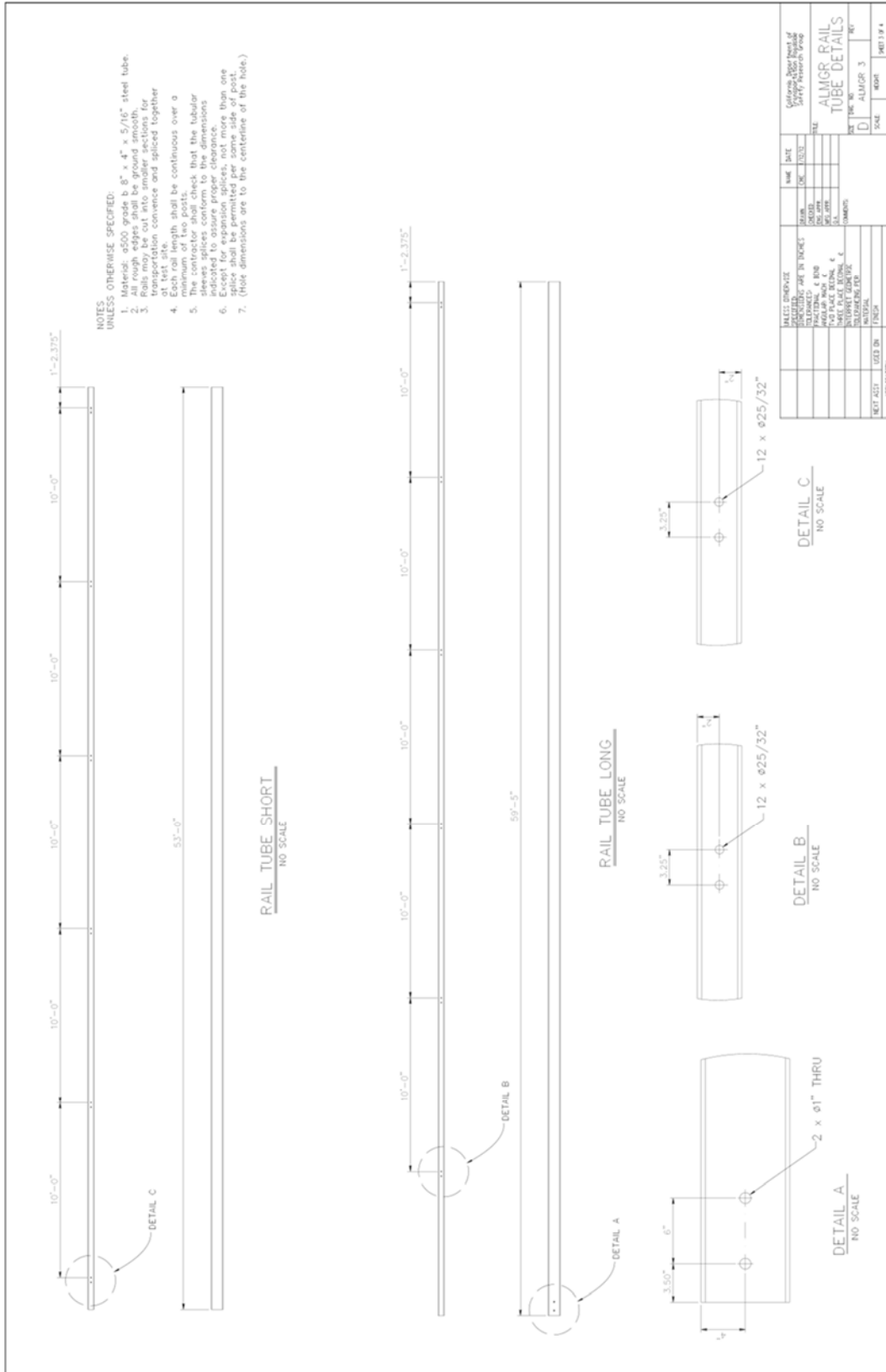
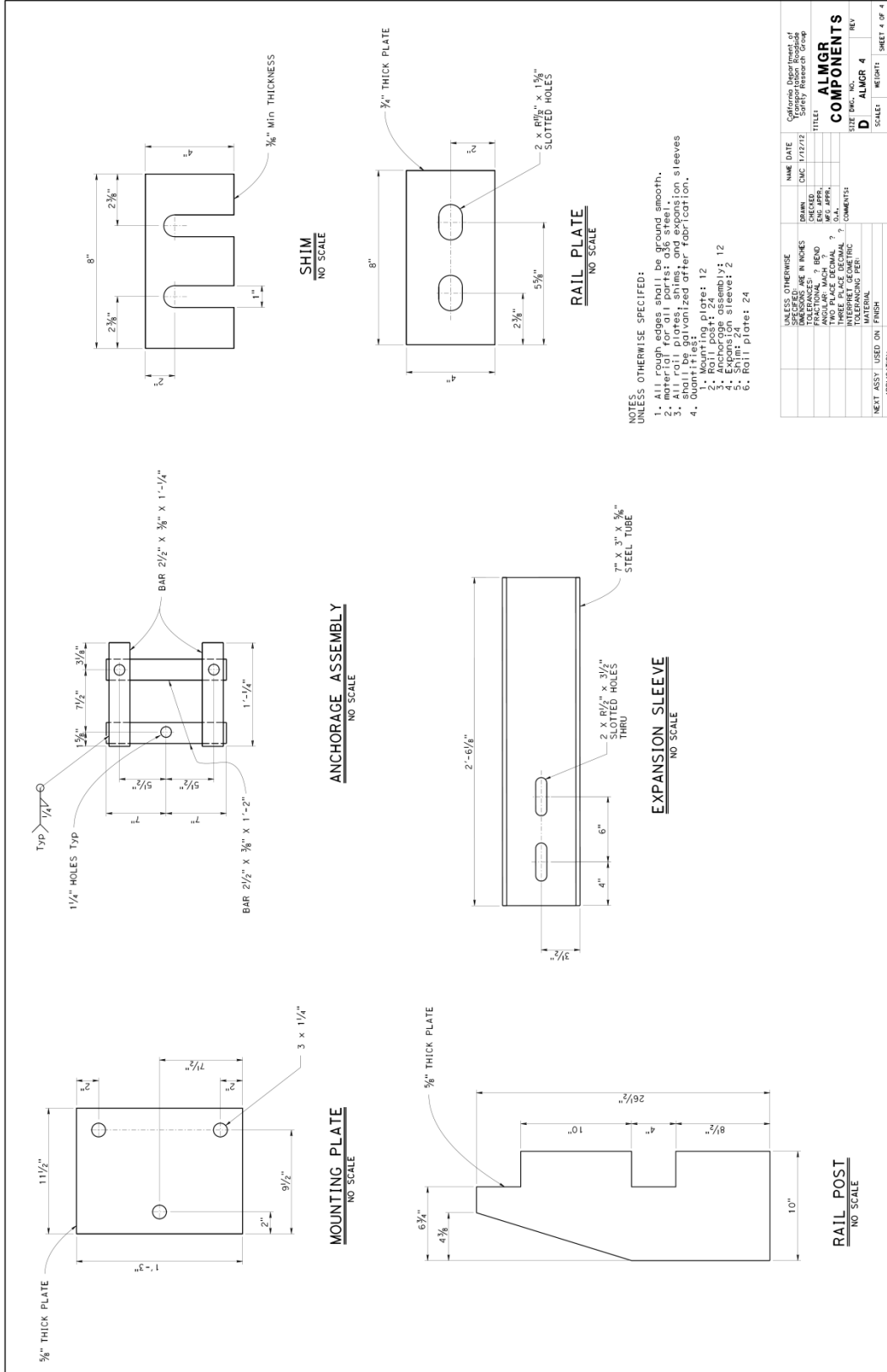

Figure 10-7 ALMGR Test Article Tube Details



- NOTES:
 UNLESS OTHERWISE SPECIFIED:
 1. All rough edges shall be ground smooth.
 2. Material for all parts shall be steel.
 3. All parts shall be galvanized after fabrication.
 4. Quantities:
 1. Rail post: 12
 2. Anchor assembly: 12
 3. Shim: 24
 4. Rail plate: 24

UNLESS OTHERWISE SPECIFIED:	NAME	DATE
DRAWING	CDC	1/17/22
DESIGNED BY		
ENGINEER		
CHECKED BY		
TITLE	ALMGR COMPONENTS	
SCALE	AS SHOWN	
PROJECT NO.	D ALMGR 4	
REVISED BY		
DATE		
WEIGHT		
SHEET	4 OF 4	

Figure 10-8 ALMGR Test Article Components

10.2 Test Vehicle Properties

Table 10-1 Vehicle Specifications Test 130MASH3P13-3

Date: 8/23/2013 Test Number: 130MASH3P13-3 Model: Ram 1500
 Make: Dodge Vehicle I.D. #: 1D7HA18N66J151472
 Tire Size: P245/70R17 Year: 2006 Odometer: 113,816

*(All Measurements Refer to Impacting Side)

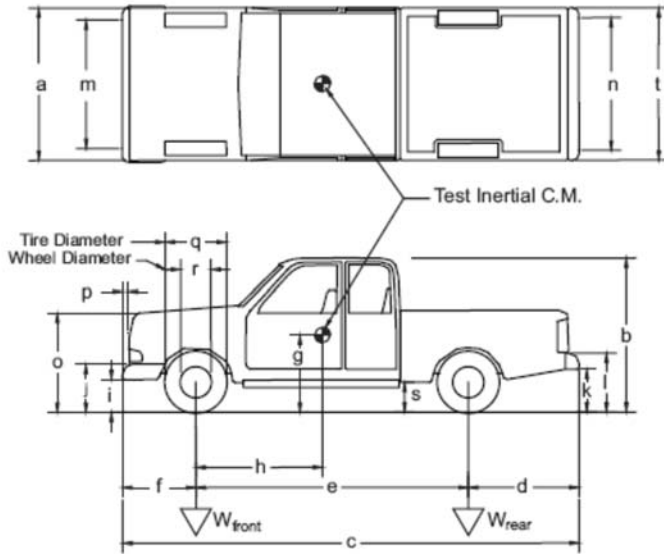

Vehicle Geometry – mm (in)

a 1980 mm (78.0 inches) b 1878 mm (73.9 inches)
 c 5791 mm (228.0 inches) d 1208 mm (47.5 inches)
 e 3575 mm (140.7 inches) f 1010 mm (39.8 inches)
 g 711 mm (28.0 inches) h 1547 mm (60.9 inches)
 i 260 mm (10.2 inches) j 645 mm (25.4 inches)
 k 525 mm (20.7 inches) l 742 mm (29.2 inches)
 m 1740 mm (68.5 inches) n 1700 mm (66.9 inches)
 o 1110 mm (43.7 inches) p 70 mm (2.7 inches)
 q 770 mm (30.3 inches) r 432 mm (17.0 inches)
 s 400 mm (15.7 inches) t 1943 mm (76.5 inches)

Wheel Center Height Front 362 mm (14.3 inches)

Wheel Center Height Rear 365 mm (14.4 inches)

Wheel Well Clearance (F) 135 mm (5.3 inches)

Wheel Well Clearance (R) 225 mm (8.9 inches)

Engine Type V-8 gas

Engine Size 4.7L

Transmission Type:

Automatic or Manual: Automatic

FWD or RWD or 4WD: RWD

Mass Distribution

LF 617.05 kg (1360.4 lbs) RF 626.75 kg (1381.7 lbs)

LR 475.35 kg (1048.0 lbs) RR 509.20 kg (1122.6 lbs)

Weights

Kg (Lbs)	Curb	Test Inertial
W_{Front}	<u>1284.5 kg (2831.8 lbs)</u>	<u>1291.3 kg (2846.8 lbs)</u>
W_{Rear}	<u>948.7 kg (2091.5 lbs)</u>	<u>984.55 kg (2170.6 lbs)</u>
W_{total}	<u>2233.2 kg (4923.4 lbs)</u>	<u>2275.85 kg (5017.4 lbs)</u>

GVWR Ratings

Front 1679 kg (3700 lbs)
 Back 1770 kg (3900 lbs)
 Total 3040 kg (6700 lbs)

Dummy Data

Type: N/A
 Mass: N/A
 Seat Position: N/A

Note any damage prior to test: Small dent in center of rear bumper, small dent passenger side of rear bumper.

Table 10-2 Vehicle Center of Gravity Measurements Test 130MASH3P13-3

Vehicle Center of Gravity Measurements

Project Title: Aesthetic Low Maintenance Guardrail Project: St-10 Bridge Rail on Trench Footing Foundation

Vehicle Test Number: 130MASH3P13-03 Model: Ram 1500

Make: Dodge Year: 2006

VIN: 1D7HA18N66J151472

Vehicle Weights (Test Inertail):

Left Front Tire: 664.6 kg Right Front Tire: 626.8 kg Front Axle: 1291.3 kg

Left Rear Tire: 475.4 kg Right Rear tire: 509.2 kg Rear Axle: 984.6 kg

Ballast and Location: 47.3 kg added to the front of the truck bed Total: 2275.9 kg

Vehicle Wheel Base Measurements:

Vehicle length from center of front tires to center of back tires: 3575.0 mm

Vehicle width from center of left front tire to center of right front tire: 1740.0 mm

Vehicle width from center of left rear tire to center of right rear tire: 1700.0 mm

Center of Gravity:

X: 1546.7 mm Center of front tire to CG.

Y: -1.8 mm The CG will be left if negative and right if positive of vehicle's center line.

Z: 711.0 mm CG location above ground level

Table 10-3 Occupant Compartment Measurement in Millimeters for Test 130MASH3P13-3

Vehicle Type	2270P	Test Number	130MASH3P13-03
Make	Dodge	Model	Ram 1500
Year	Dodge	Color	Gray
VIN #	2006		

Floorboard Measurements: Dimensions in mm (inches)

Point	Pre-Impact			Post-Impact			Difference		
	X	Y	Z	X	Y	Z	ΔX	ΔY	ΔZ
F1	1461 (57.5)	-320 (-12.6)	199 (7.8)	1445 (56.9)	-316 (-12.4)	183 (7.2)	-16 (-0.6)	4 (0.2)	-16 (-0.6)
F2	1461 (57.5)	-450 (-17.7)	198 (7.8)	1443 (56.8)	-445 (-17.5)	185 (7.3)	-18 (-0.7)	5 (0.2)	-13 (-0.5)
F3	1461 (57.5)	-576 (-22.7)	198 (7.8)	1451 (57.1)	-570 (-22.4)	188 (7.4)	-10 (-0.4)	6 (0.2)	-10 (-0.4)
F4	1461 (57.5)	-704 (-27.7)	198 (7.8)	1454 (57.2)	-696 (-27.4)	191 (7.5)	-7 (-0.3)	8 (0.3)	-7 (-0.3)
F5	1580 (62.2)	-320 (-12.6)	300 (11.8)	1577 (62.1)	-308 (-12.1)	283 (11.1)	-3 (-0.1)	12 (0.5)	-17 (-0.7)
F6	1580 (62.2)	-450 (-17.7)	300 (11.8)	1581 (62.2)	-437 (-17.2)	286 (11.3)	1 (0.0)	13 (0.5)	-14 (-0.6)
F7	1580 (62.2)	-576 (-22.7)	299 (11.8)	1579 (62.2)	-566 (-22.3)	289 (11.4)	-1 (0.0)	10 (0.4)	-10 (-0.4)
F8	1580 (62.2)	-704 (-27.7)	301 (11.9)	1594 (62.8)	-688 (-27.1)	294 (11.6)	14 (0.6)	16 (0.6)	-7 (-0.3)
F9	1706 (67.2)	-320 (-12.6)	299 (11.8)	1713 (67.4)	-308 (-12.1)	282 (11.1)	7 (0.3)	12 (0.5)	-17 (-0.7)
F10	1706 (67.2)	-450 (-17.7)	298 (11.7)	1716 (67.6)	-437 (-17.2)	286 (11.3)	10 (0.4)	13 (0.5)	-12 (-0.5)
F11	1706 (67.2)	-576 (-22.7)	300 (11.8)	1717 (67.6)	-564 (-22.2)	292 (11.5)	11 (0.4)	12 (0.5)	-8 (-0.3)
F12	1706 (67.2)	-704 (-27.7)	303 (11.9)	1724 (67.9)	-688 (-27.1)	300 (11.8)	18 (0.7)	16 (0.6)	-3 (-0.1)
F13	1842 (72.5)	-320 (-12.6)	300 (11.8)	1828 (72.0)	-307 (-12.1)	287 (11.3)	-14 (-0.6)	13 (0.5)	-13 (-0.5)
F14	1842 (72.5)	-450 (-17.7)	300 (11.8)	1831 (72.1)	-434 (-17.1)	288 (11.3)	-11 (-0.4)	16 (0.6)	-12 (-0.5)
F15	1842 (72.5)	-576 (-22.7)	300 (11.8)	1838 (72.4)	-561 (-22.1)	291 (11.5)	-4 (-0.2)	15 (0.6)	-9 (-0.4)
F16	1842 (72.5)	-704 (-27.7)	300 (11.8)	1838 (72.4)	-687 (-27.0)	298 (11.7)	-4 (-0.2)	17 (0.7)	-2 (-0.1)
F17	1966 (77.4)	-320 (-12.6)	296 (11.7)	1945 (76.6)	-305 (-12.0)	284 (11.2)	-21 (-0.8)	15 (0.6)	-12 (-0.5)
F18	1966 (77.4)	-450 (-17.7)	294 (11.6)	1950 (76.8)	-432 (-17.0)	288 (11.3)	-16 (-0.6)	18 (0.7)	-6 (-0.2)
F19	1966 (77.4)	-576 (-22.7)	295 (11.6)	1965 (77.4)	-559 (-22.0)	293 (11.5)	-1 (0.0)	17 (0.7)	-2 (-0.1)
F20	1966 (77.4)	-704 (-27.4)	290 (11.4)	1960 (77.2)	-686 (-27.0)	278 (10.9)	-6 (-0.2)	18 (0.7)	-12 (-0.5)
F21	2110 (83.1)	-320 (-12.6)	220 (8.7)	2091 (82.3)	-309 (-12.2)	213 (8.4)	-19 (-0.7)	11 (0.4)	-7 (-0.3)
F22	2120 (83.5)	-450 (-17.7)	223 (8.8)	2081 (81.9)	-432 (-17.0)	215 (8.5)	-39 (-1.5)	18 (0.7)	-8 (-0.3)
F23	2120 (83.5)	-576 (-22.7)	222 (8.7)	2087 (82.2)	-556 (-21.9)	206 (8.1)	-33 (-1.3)	20 (0.8)	-16 (-0.6)
F24	2120 (83.5)	-704 (-27.7)	220 (8.7)	2083 (82.0)	-672 (-26.5)	210 (8.3)	-37 (-1.5)	32 (1.3)	-10 (-0.4)
F25	2230 (87.8)	-450 (-17.7)	166 (6.5)	2230 (87.8)	-431 (-17.0)	161 (6.3)	0 (0.0)	19 (0.7)	-5 (-0.2)
F26	2225 (87.6)	-576 (-22.7)	170 (6.7)	2220 (87.4)	-554 (-21.8)	164 (6.5)	-5 (-0.2)	22 (0.9)	-6 (-0.2)
F27	2220 (87.4)	-704 (-27.7)	115 (4.5)	2150 (84.6)	-667 (-26.3)	96 (3.8)	-70 (-2.8)	37 (1.5)	-19 (-0.7)

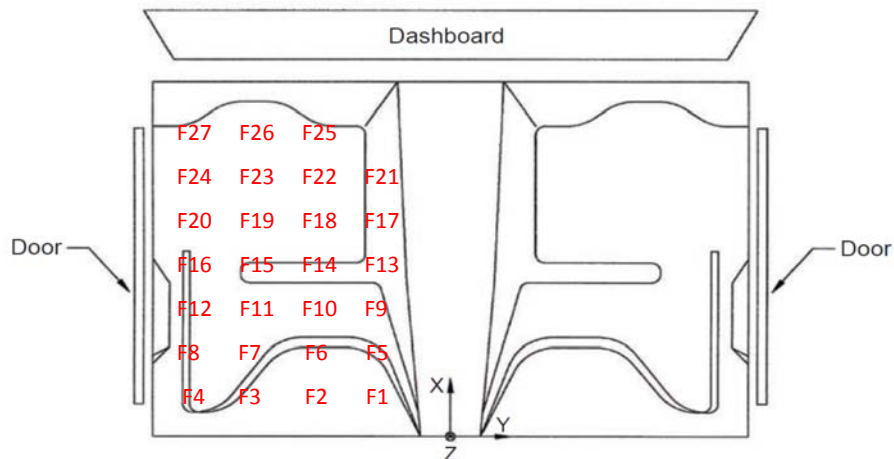

Vehicle Type	2270P	Test Number	130MASH3P13-03
Make	Dodge	Model	Ram 1500
Year	2006	Color	Gray
VIN #	1D7HA18N66J151472		

Dashboard Measurements: Dimensions in mm (inches)

Point	Pre-Impact			Post-Impact			Difference		
	X	Y	Z	X	Y	Z	ΔX	ΔY	ΔZ
D1	1801 (70.9)	-692 (-27.2)	-487 (-19.2)	1793 (70.6)	-688 (-27.1)	-515 (-20.3)	-8 (-0.3)	4 (0.2)	-28 (-1.1)
D2	1781 (70.1)	-477 (-18.8)	-556 (-21.9)	1776 (69.9)	-470 (-18.5)	-575 (-22.6)	-5 (-0.2)	7 (0.3)	-19 (-0.7)
D3	1794 (70.6)	-260 (-10.2)	-526 (-20.7)	1791 (70.5)	-255 (-10.0)	-554 (-21.8)	-3 (-0.1)	5 (0.2)	-28 (-1.1)
D4	1764 (69.4)	0 (0.0)	-556 (-21.9)	1759 (69.3)	5 (0.2)	-574 (-22.6)	-5 (-0.2)	5 (0.2)	-18 (-0.7)
D5	1803 (71.0)	245 (9.6)	-519 (-20.4)	1799 (70.8)	254 (10.0)	-549 (-21.6)	-4 (-0.2)	9 (0.4)	-30 (-1.2)

Roof Measurements: Dimensions in mm (inches)

Point	Pre-Impact			Post-Impact			Difference		
	X	Y	Z	X	Y	Z	ΔX	ΔY	ΔZ
R1	1006 (39.6)	-576 (-22.7)	-934 (-36.8)	1003 (39.5)	-574 (-22.6)	-955 (-37.6)	-3 (-0.1)	2 (0.1)	-21 (-0.8)
R2	1006 (39.6)	-450 (-17.7)	-1010 (-39.8)	1003 (39.5)	-446 (-17.6)	-1023 (-40.3)	-3 (-0.1)	4 (0.2)	-13 (-0.5)
R3	1211 (47.7)	-576 (-22.7)	-918 (-36.1)	1204 (47.4)	-570 (-22.4)	-946 (-37.2)	-7 (-0.3)	6 (0.2)	-28 (-1.1)
R4	1211 (47.7)	-450 (-17.7)	-985 (-38.8)	1207 (47.5)	-445 (-17.5)	-998 (-39.3)	-4 (-0.2)	5 (0.2)	-13 (-0.5)
R5	1211 (47.7)	-320 (-12.6)	-1000 (-39.4)	1203 (47.4)	-319 (-12.6)	-1016 (-40.0)	-8 (-0.3)	1 (0.0)	-16 (-0.6)
R6	1211 (47.7)	-178 (-7.0)	-1014 (-39.9)	1203 (47.4)	-175 (-6.9)	-1027 (-40.0)	-8 (-0.3)	3 (0.1)	-13 (-0.5)
R7	1461 (57.5)	-450 (-17.7)	-916 (-36.1)	1453 (57.2)	-447 (-17.6)	-932 (-36.7)	-8 (-0.3)	3 (0.1)	-16 (-0.6)
R8	1461 (57.5)	-320 (-12.6)	-930 (-36.6)	1452 (57.2)	-315 (-12.4)	-948 (-37.3)	-9 (-0.4)	5 (0.2)	-18 (-0.7)
R9	1461 (57.5)	-178 (-7.0)	-938 (-36.9)	1449 (57.0)	-173 (-6.8)	-953 (-37.5)	-12 (-0.5)	5 (0.2)	-15 (-0.6)
R10	1461 (57.5)	0 (0.0)	-942 (-37.1)	1457 (57.4)	3 (0.1)	-951 (-37.4)	-4 (-0.2)	3 (0.1)	-9 (-0.4)

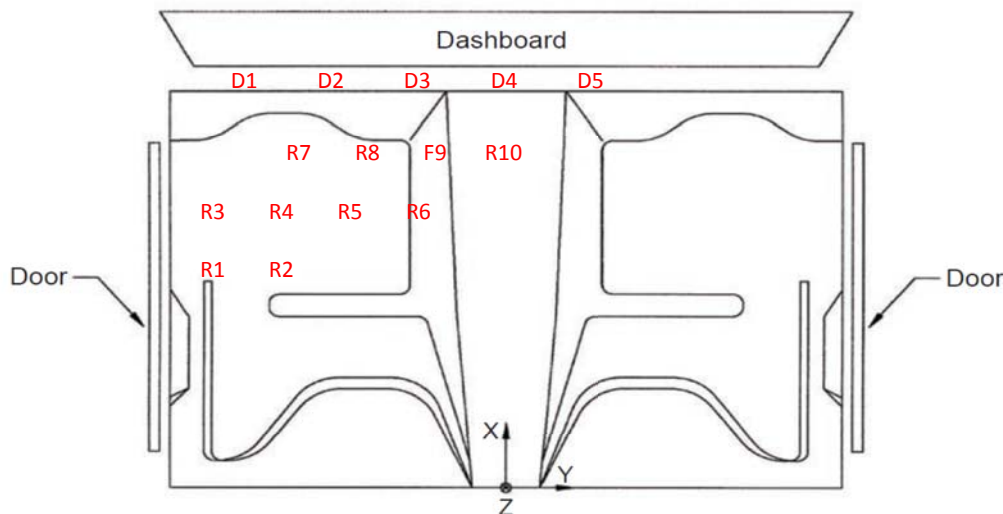

10.3 130MASH3P13-03 Crash Test Sequence Photographs

10.3.1 Upstream Sequence



Upstream Sequence 1



Upstream Sequence 2



Upstream Sequence 3



Upstream Sequence 4



Upstream Sequence 5



Upstream Sequence 6



Upstream Sequence 7



Upstream Sequence 8



Upstream Sequence 9

10.3.2 Across Sequence



Pan Sequence 1



Pan Sequence 2



Pan Sequence 3



Pan Sequence 4



Pan Sequence 5



Pan Sequence 6



Pan Sequence 7



Pan Sequence 8



Pan Sequence 9



Pan Sequence 10



Pan Sequence 11



Pan Sequence 12

10.4 Vehicle Angular Displacement and Accelerations

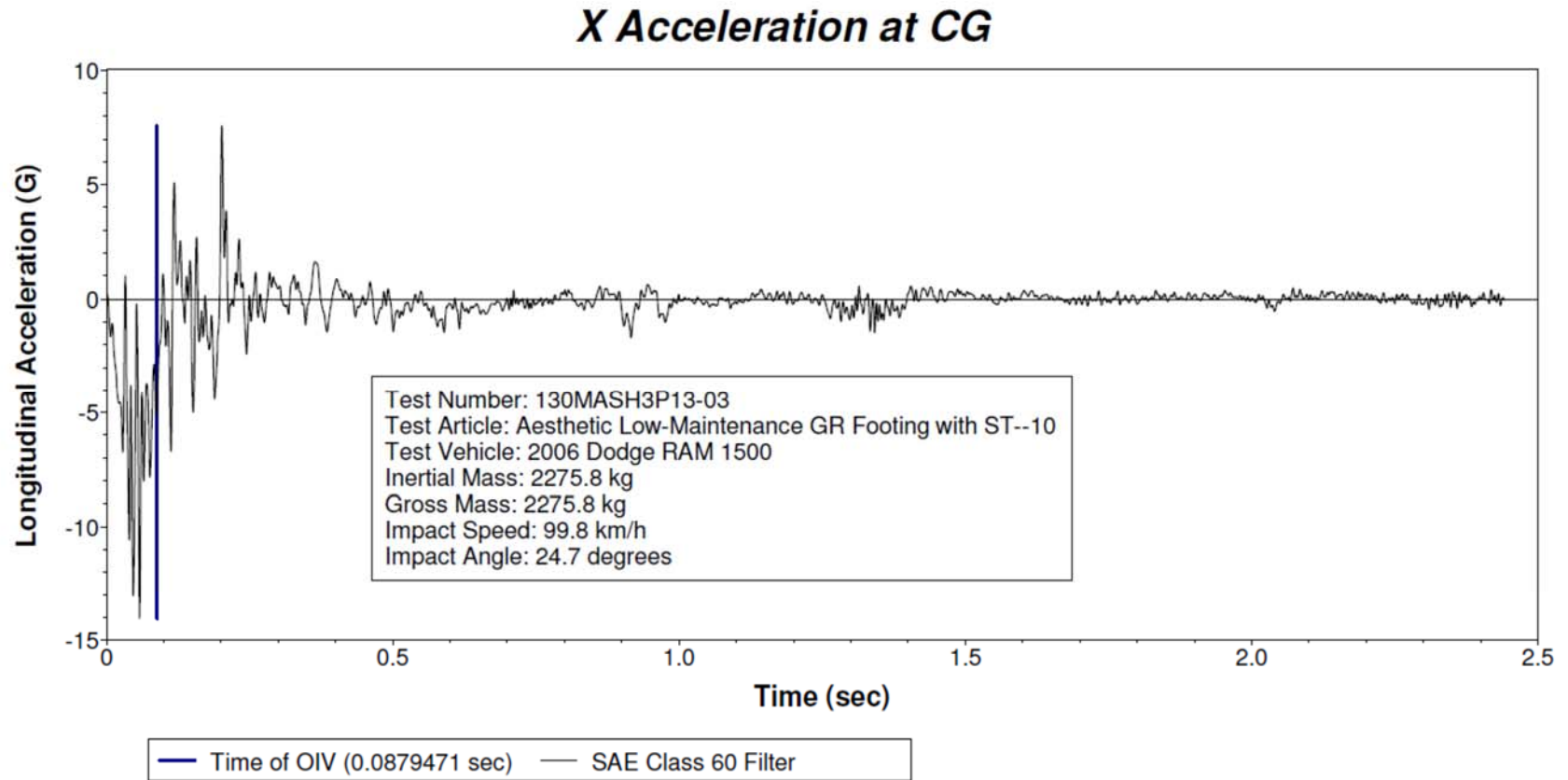

Figure 10-9 Vehicle Longitudinal Accelerometer trace for Test 130MASH3P13-03

Y Acceleration at CG

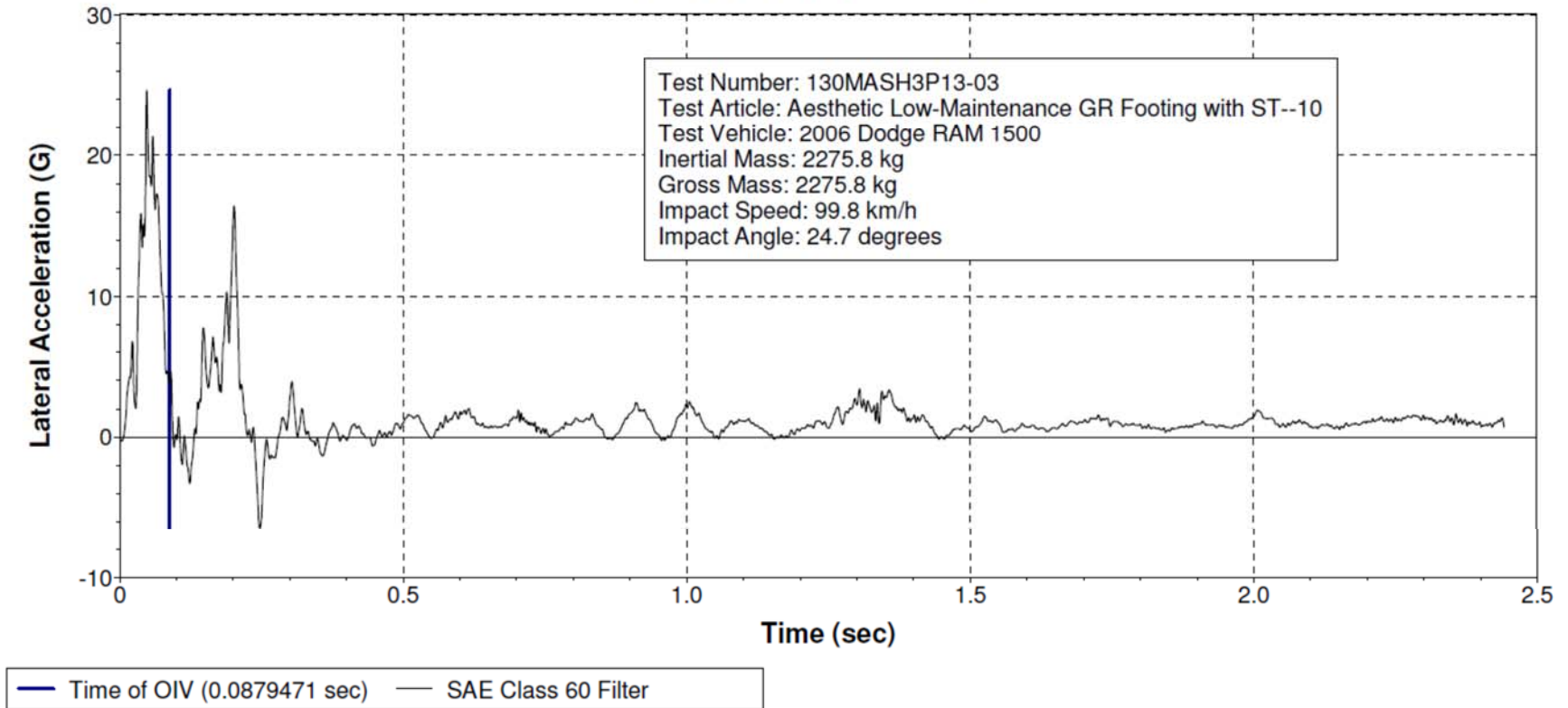

Figure 10-10 Vehicle Lateral Accelerometer trace for Test 130MASH3P13-03

Z Acceleration at CG

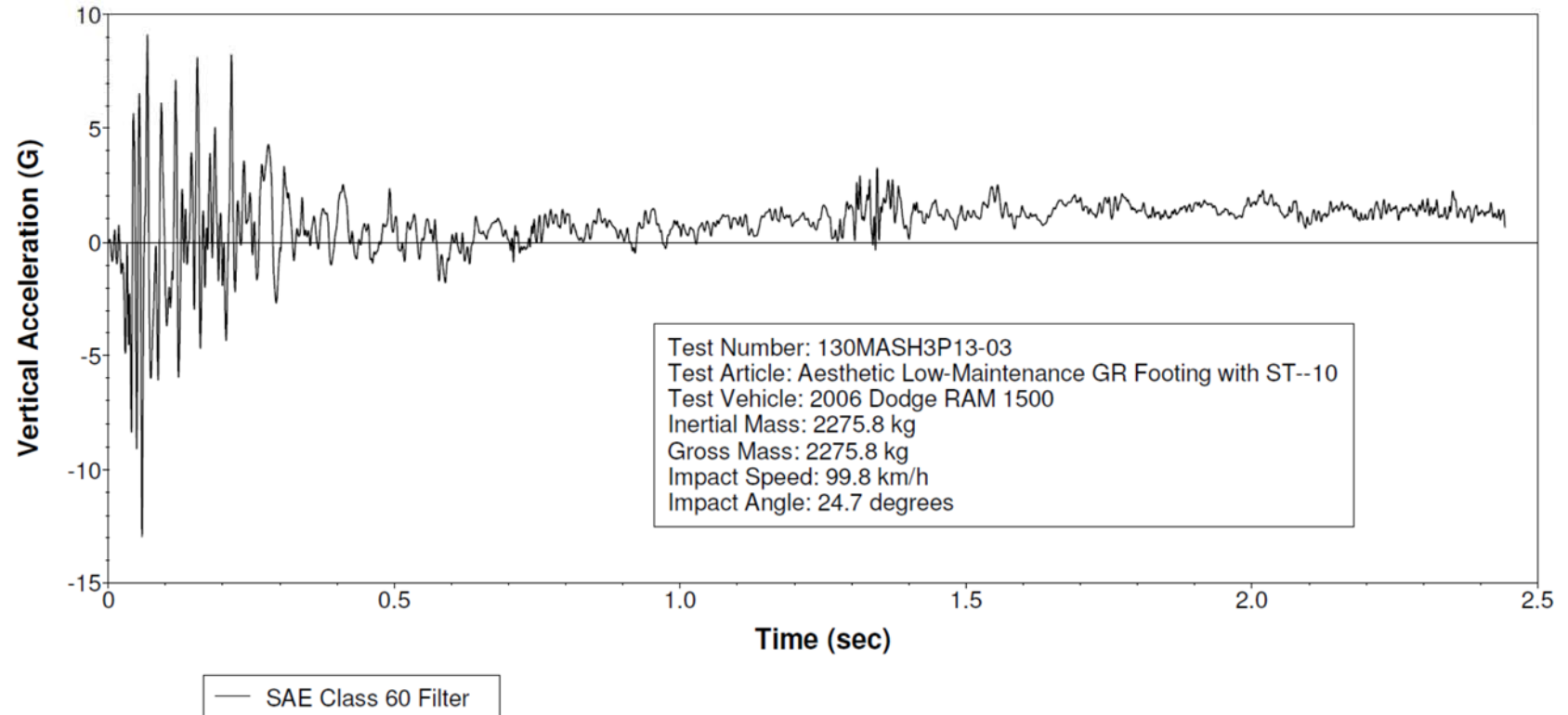

Figure 10-11 Vehicle Vertical Accelerometer Trace for Test 130MASH3P13-03

Roll, Pitch and Yaw Angles

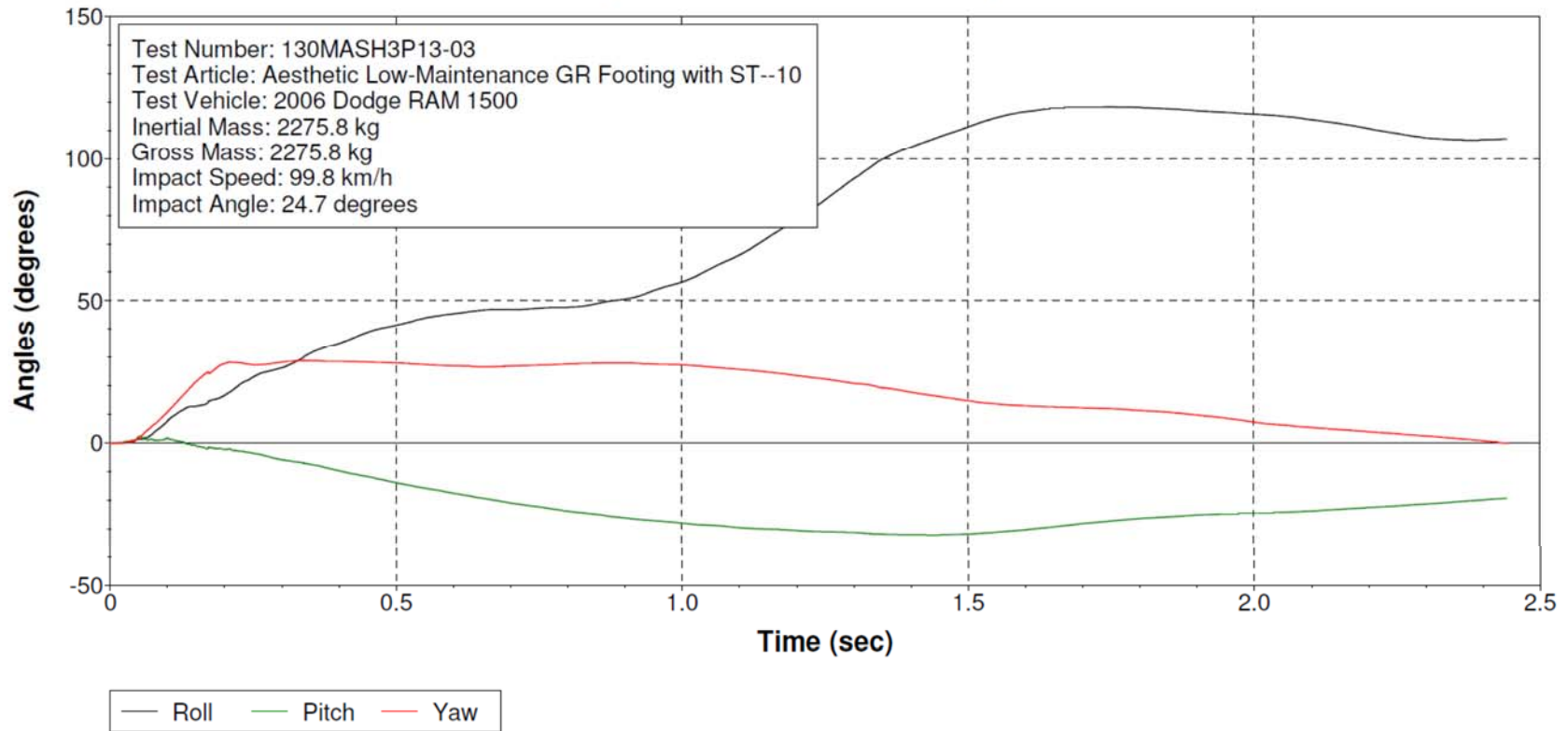

Figure 10-12 Vehicle Angular Displacements for Test 130MASH3P13-03

Roll, Pitch and Yaw Rates

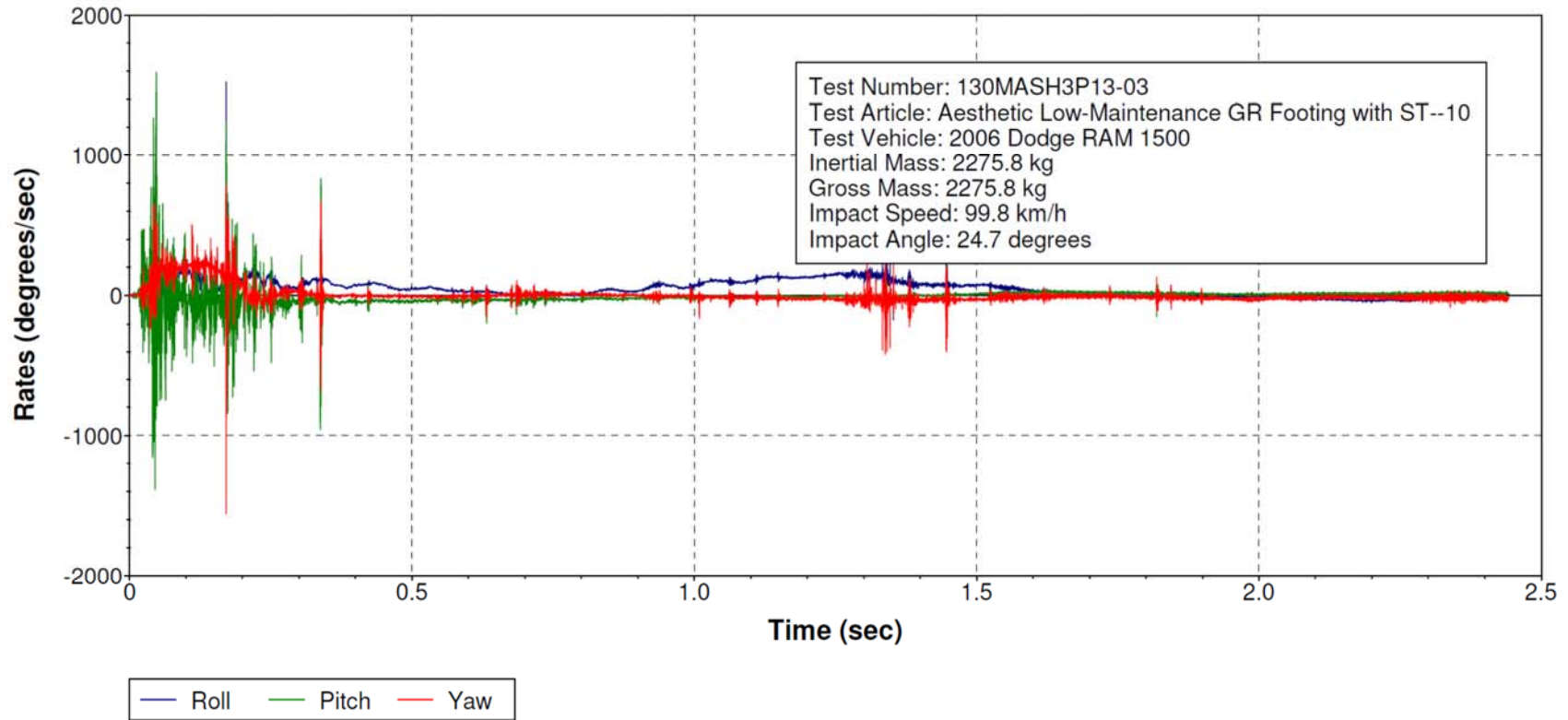

Figure 10-13 Vehicle Angular Rate of Change for Test 130MASH3P13-03

ASI

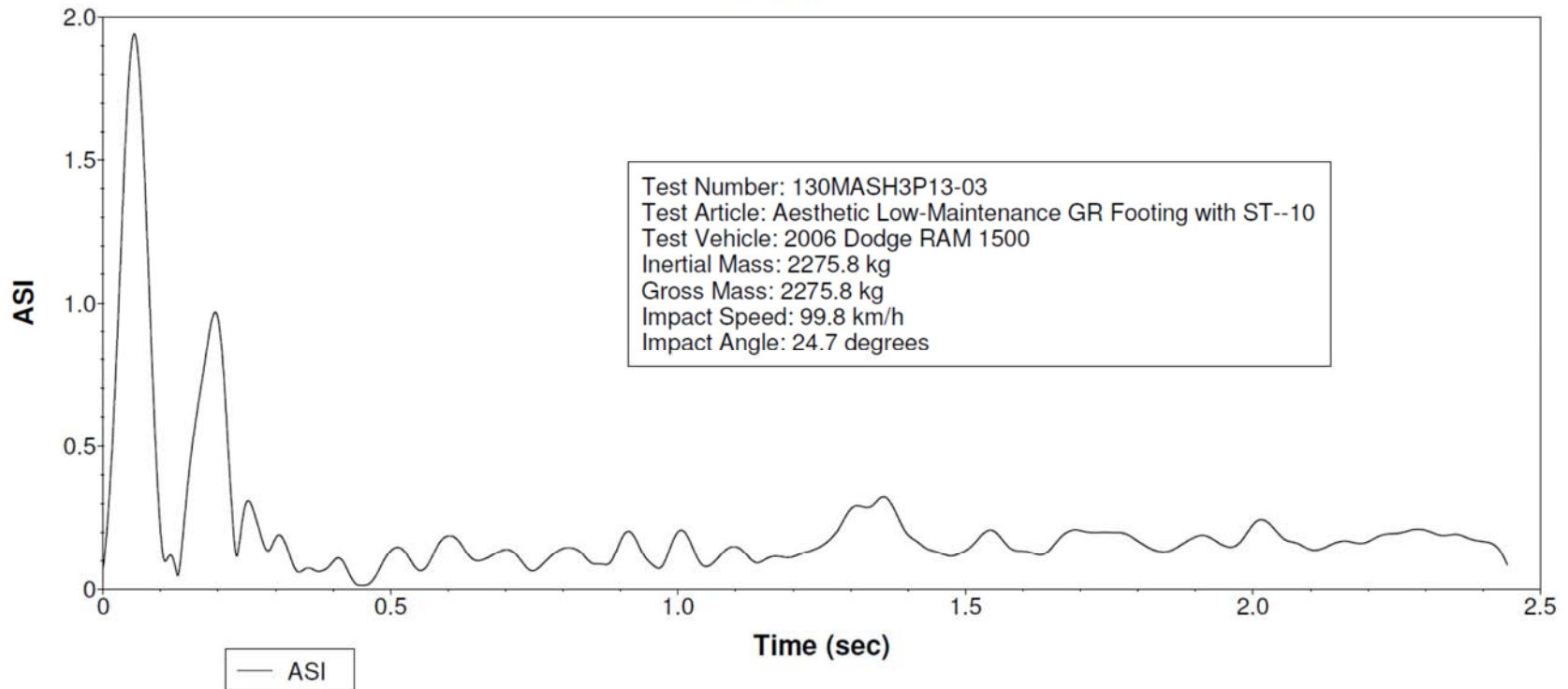

Figure 10-14 Acceleration Severity Index for Test 130MASH3P13-03

10.5 Finite Element Analysis[†]

The purpose of this section is to record the Lab's experience with finite element modeling and analysis.

Finite element (FE) analysis was performed using LS-Dyna, which is a commercial finite element software commonly used for crashworthiness analysis. The purpose of the modeling was to see what movement would be found in the foundation and the reaction of a vehicle impacting the combination of bridge rail and foundation. It was hoped that if the foundation's movement in the model's soil could be validated by a full scale crash test other foundation configurations could be simulated with little or no need for full scale testing.

The soil model used for the simulations originated from a previous project titled "Development and Testing of a Low-Profile Barrier" report number FHWA/CA10-0645. Soil is difficult to effectively model for these types of impacts. Based on past soil modeling, there was a lack of confidence that the soil simulation results would accurately or reliably reflect physical testing. For this reason, and to check the vehicle barrier interaction, a fully constrained barrier was simulated as well.

There were some problems initially with the simulations being unstable and either having an error termination or just stopping without reaching its end termination time. The Livermore Software Technology Corporation, LS-Dyna's developer, was contacted for help with the problem and they found that there were too many redundant contact definitions. Once the redundant definitions were removed the models were stable and would run to their termination times.

After a full scale test was conducted, it was decided that there should be one more simulation run with the foundation and the base of the rail posts constrained and everything above the base

[†] This section is outside of the RSRG's A2LA accreditation #3046.01

was free to move. This was done to see if the results of this simulation would better match with the results of the full scale crash test.

10.5.1 Barrier Models

Two models were developed before the full scale testing and a model was developed after the testing. All of the models were processed with LS-Dyna. All of the models were designed to simulate a MASH 3-11 test which has a pickup truck (designated 2270P) impacting a longitudinal barrier at a speed of 62.2 mph (100 km/h) and an angle of 25 degrees. The length of test article in all of the models was 51 feet (15.6 m). One pre-test model utilized a fully constrain ST-10 bridge rail barrier. The other pre-test model utilized a 30-inch (762-mm) by 20-inch (508-mm) concrete trench foundation imbedded in a weak soil. The post-test model was similar to the model with the concrete foundation imbedded in a weak soil but the system was partially constrained. See below for more details.

10.5.1.1 Fully Constrained Test Article Model

The Fully Constrained Test Article finite element model has all of the nodes that make up the mesh in the ST-10 bridge rail and curb constrained so that they cannot translate or rotate in any direction or axis. This was done to test the contact definitions between the truck and the barrier and to get an idea of the result of a MASH truck hitting the ST-10 bridge rail.

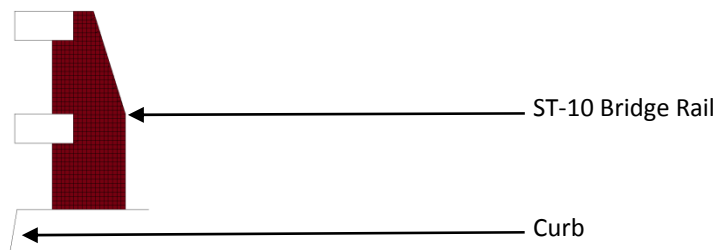

Figure 10-15 Fully Constrained Test Article

10.5.1.2 Test Article in Soil Block Model

The 30-inch (762-mm) by 20-inch (508-mm) wide concrete trench foundation was imbedded in a loose sand model that had a density of 90 pcf (1442 kg/m³). The sand model extended behind the barrier by 70 inches (1778 mm) and 20 inches (508 mm) below the barrier. There is no rebar in the concrete trench foundation model. The ST-10 bridge rail was mounted on top of the trench foundation. The purpose of this model was to represent the real world crash test as closely as possible.

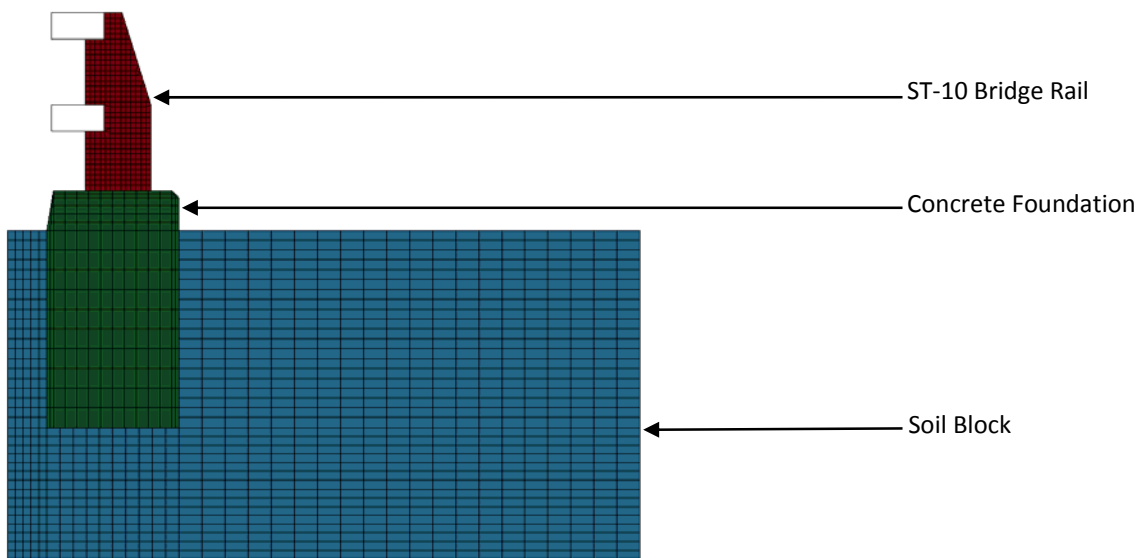

Figure 10-16 Test Article in Soil Block Model

10.5.1.3 Partially Constrained Test Article Model

The Partially Constrained Test Article model is similar to the Test Article in Soil Block model except that all of the nodes in the soil block, the foundation, and the base of the rail post are constrained to prevent any rotation or translation. This simulation was conducted after the full scale test to see if this model would better represent the results of the full scale crash test.

10.5.2 Vehicle Model

The vehicle model used in the virtual tests was a 2270-kg 2007 Chevy Silverado version 2. This model is free to use and was developed by the National Crash Analysis Center (NCAC). This vehicle model and more are available at www.ncac.gwu.edu/vml/models.html. The only change to the vehicle model was to increase the velocity of the model to match the required speed for a MASH Test Level 3.



Figure 10-17 MASH 2270P Test Vehicle

10.5.3 Actual Crash Test Vs. Simulated Crash Tests

Section 10.5.3.1 compares the movement of the test article in the full scale test to the movement in the simulated tests. Section 10.5.3.2 compares the data from the actual crash test and the data from LS-Dyna FE model simulations. Section 10.5.3.3 is a visual comparison of the actual crash test and the FE model simulations.

10.5.3.1 Test Article Movement Comparison

Only the Soil Block model and the Partially Constrained model can be used when comparing the actual crash test movement to the simulated crash test movement of the ST-10 bridge rail and foundation. The Fully Constrained Test Article model was not compared because all of the nodes in the test article were fixed so that they would not move. The movement of the test article during the full scale test was minimal and was measured by string potentiometers, see Section 5.6.1. The top rail had a dynamic deflection of 0.6 inches (15 mm) and a static displacement of 0.4 inches (10 mm). The top of the curb had a dynamic deflection of 0.1 inches (3 mm) and a

negligible static displacement. Movement in the Soil Block model was extreme and would have been considered a failure, see FiguresFigure 10-18 through Figure 10-20. The Partially Constrained model was constrained to allow no movement at the curb but the top of the rail had a dynamic deflection of 0.2 inches (5 mm) and the static displacement was negligible. See Table 10-4 for a tabulated comparison.

Table 10-4 Full Scale Test, Test Article in Soil Block Model, and Partially Constrained Model Movement

Test Article Movement	Test 130MASH3P13-03	Test Article in Soil Block Model	Partially Constrained Model
Top Rail Dynamic Deflection	0.6 inch (15 mm)	2.4 inch (70 mm)	0.2 inch (5 mm)
Top Rail Static Displacement	0.4 inch (10 mm)	1.6 inch (41 mm)	0.0 inch (0 mm)
Top of Curb Dynamic Deflection	0.1 inch (3 mm)	2.1 inch (53 mm)	Constrained
Top of Curb Static Displacement	0.0 inch (0 mm)	1.6 inch (41 mm)	Constrained

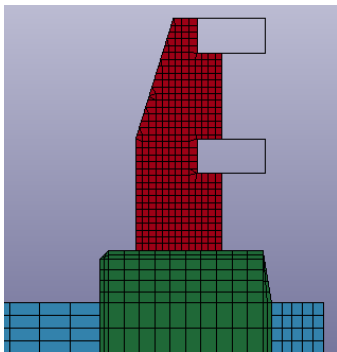

Figure 10-18 Soil Block Model Before Impact Profile

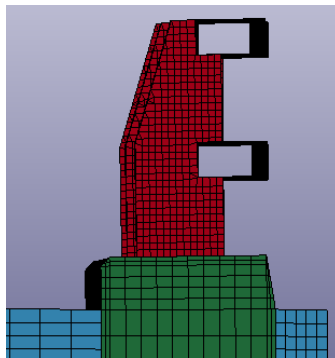

Figure 10-19 Soil Block Model Max Dynamic Displacement Profile

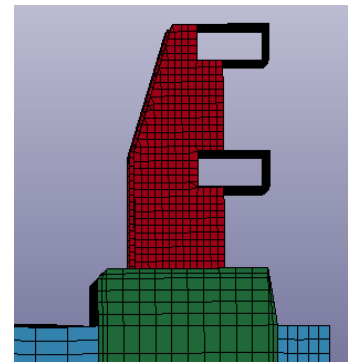

Figure 10-20 Soil Block Model Max Static Displacement Profile

10.5.3.2 Data Comparison

The accelerometer and angular rate sensor data gathered during the full scale test and the FE modeling were processed with Test Risk Assessment Program (TRAP) and an SAE class 180 filter. This was the first attempt by the Lab to use simulation data in TRAP; we were interested in seeing how the crash test simulations compared to the actual crash test. When the full scale test data

was compared to the FE models data it appeared that the Test Article in Soil Block model and the full scale test results were similar, with the exception of the roll, pitch, and longitudinal ridedown acceleration. The results for the Partially Constrained and Fully Constrained Test Article models were much higher than the full scale test results, with the exception of the occupant impact velocities. The models' max roll would have been similar to the actual crash test if the Partially Constrained and Fully Constrained models had been allowed to run longer, but it was stopped when it was determined visually that the vehicle was rolling over. From these results it appears that the Test Article in Soil Block model best represents the actual crash test. See Table 10-5 for all of the TRAP results.

The large discrepancies in the ridedown accelerations, especially the longitudinal accelerations, could be a result of simplifications made to the vehicle and barrier models. Based on the movement of the barrier, shown in Table 10-2, it can be assumed that the Soil Block model's accelerations would be lower than the accelerations recorded in the crash test. The higher accelerations recorded might be due to simplifications and modifications to the vehicle or barrier models. Another reason for the large discrepancies is that there might be unidentified errors in the interaction between the barrier and the vehicle.

Table 10-5 Full Scale and FE Model TRAP Results

Data Results	MASH Criteria	Test 130MASH3P13-03	Test Article in Soil Block Model*	Partially Constrained Model*	Fully Constrained Test Article Model*
Longitudinal Occupant Impact Velocity	Preferred = 9.1 m/s Max = 12.2 m/s	4.2 m/s	4.0 m/s	1.9 m/s	3.5 m/s
Longitudinal Ridedown Acceleration 10 msec Average	Preferred = 15.0 G Max = 20.49 G	4.8 G	8.3 G	23.1 G	18.3 G
Lateral Occupant Impact Velocity	Preferred = 9.1 m/s Max = 12.2 m/s	8.6 m/s	7.4 m/s	9.8 m/s	9.5 m/a
Lateral Ridedown Acceleration 10 msec Average	Preferred = 15.0 G Max = 20.49 G	13.8 G	14.5 G	19.7 G	19.8 G
PHD	n/a	14.3 G	14.6 G	26.3 G	26.8 G
ASI	n/a	1.94	1.81	2.53	2.46
Max Roll (Absolute Value)	<75 Degrees	118.5 degree	31.2 degrees	57.8 degrees	75.5 degrees
Max Pitch (Absolute Value)	<75 Degrees	32.2 degrees	15.3 degrees	5.8 degrees	19.2 degrees
Max Yaw (Absolute Value)	n/a	28.9 degrees	31.3 degrees	36.9 degrees	34.1 degrees

* The Lab has a very low level of confidence with the TRAP results of the finite element model data.

10.5.3.3 Visual Comparison

Figure 10-21 shows a comparison of the full scale crash test and the FE model simulations. In the simulations and the actual test, the vehicle appears to have similar interactions with the barrier until the vehicle begins to lose contact with the barrier and is redirected. The full scale crash test, the Fully Constrained Test Article model, and the Partially Constrained model visually have the same reactions to the barrier and ultimately have the vehicle roll on its side. The vehicle in the Test Article in Soil Block model stays upright after it loses contact with the barrier. From these visual results it appears that the Fully Constrained Test Article model and the Partially Constrained model best represent the actual crash test.

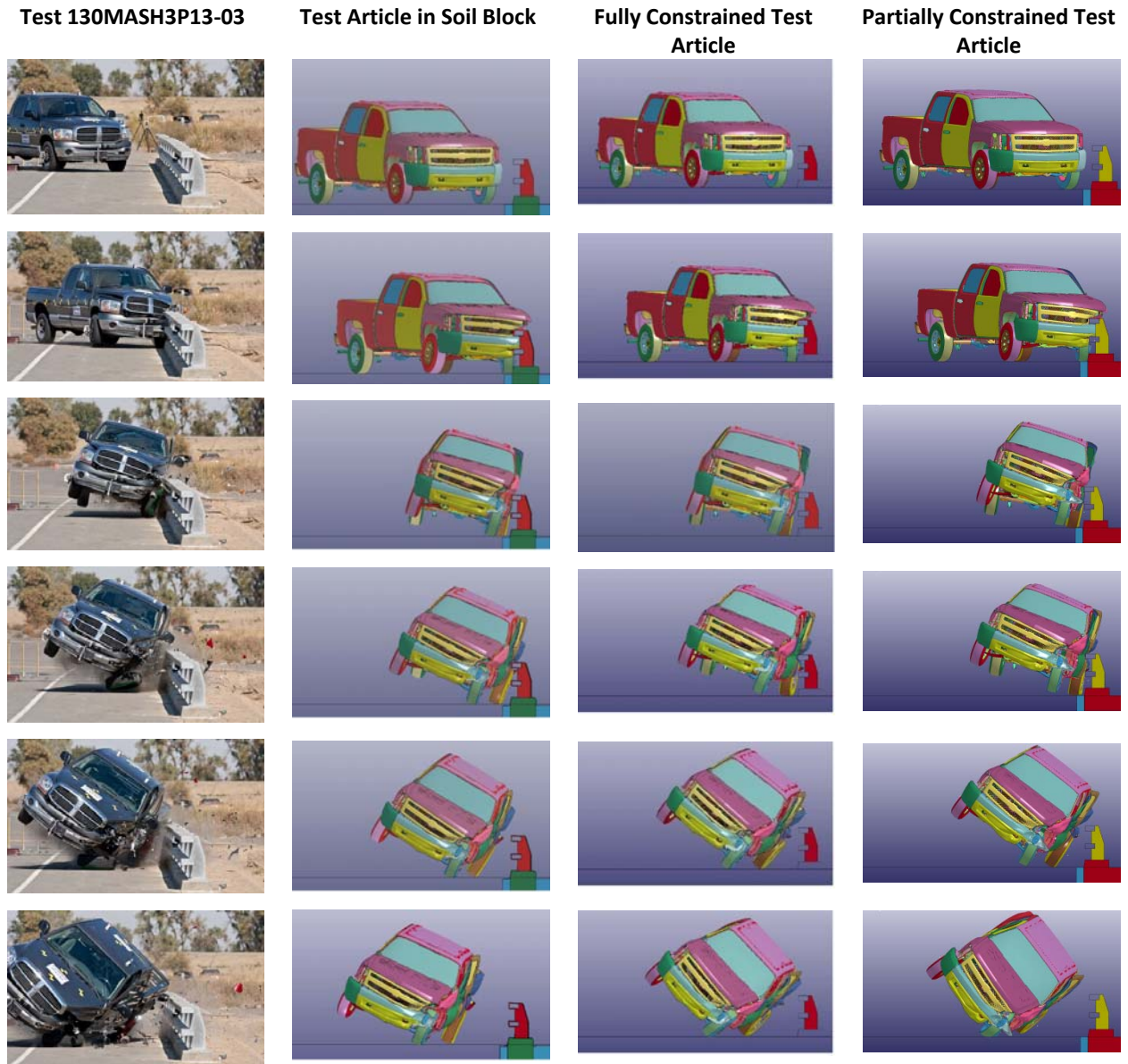

Figure 10-21 Visual Comparison of Actual Crash Test to Simulation Crash Tests

Figure 10-22 through Figure 10-24 are graphs that compare the roll, pitch, and yaw of the crash test and the simulations. Figure 10-22 shows that the vehicle's roll angle in the Fully Constrained model steadily increased to 90 degrees before the model was stopped. As stated earlier, the vehicle in this simulation would have rolled onto its side. The roll angle on the vehicle in the Partially Constrained model had a maximum of 58 degrees because the simulation was stopped. If allowed to continue the vehicle would have rolled onto its side. The vehicle's roll angle for the Soil Block model shows that the vehicle rotated about 30 degrees before starting to rotate back to its original orientation. The vehicle's roll angle for the Soil Block model shows that the vehicle rotated about 30 degrees before starting to rotate back to its original orientation. The vehicle's roll angle in the actual crash test increased steadily for about 0.6 seconds then leveled out for about 0.2 seconds before continuing to steadily increase again. At about 1.35 seconds after impact the actual test vehicle rolled onto its side.

The vehicle pitch angles for the crash test, the Fully Constrained model, and the Partially Constrained model have similar linear slopes once their angles start to decrease. The Soil Block model's vehicle pitch angle has a more parabolic shape compared to the crash test and the other two models. The yaw angles are very similar for the crash test and the simulation models.

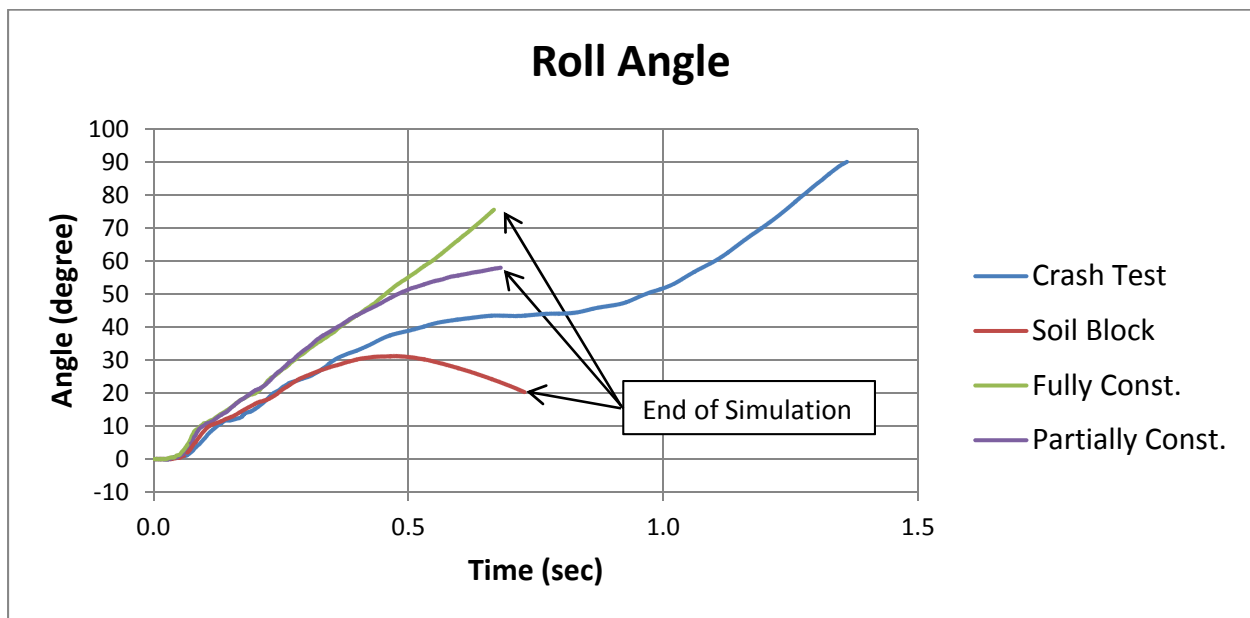

Figure 10-22 Comparing Crash Test and Simulation Roll Angles

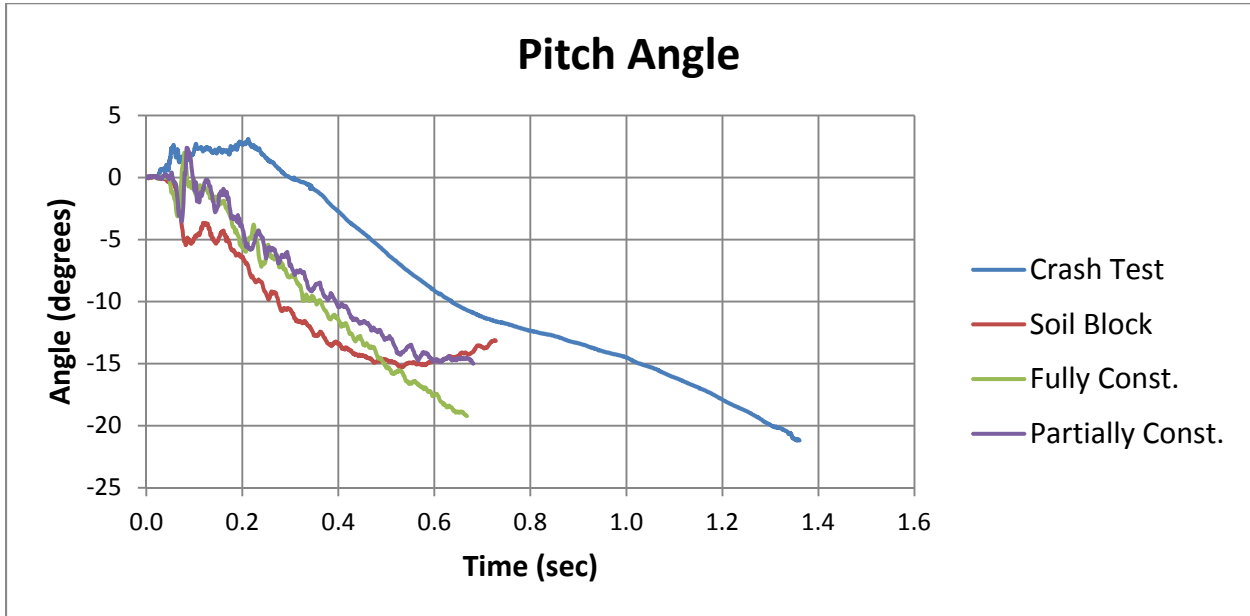

Figure 10-23 Comparing Crash Test and Simulation Pitch Angles

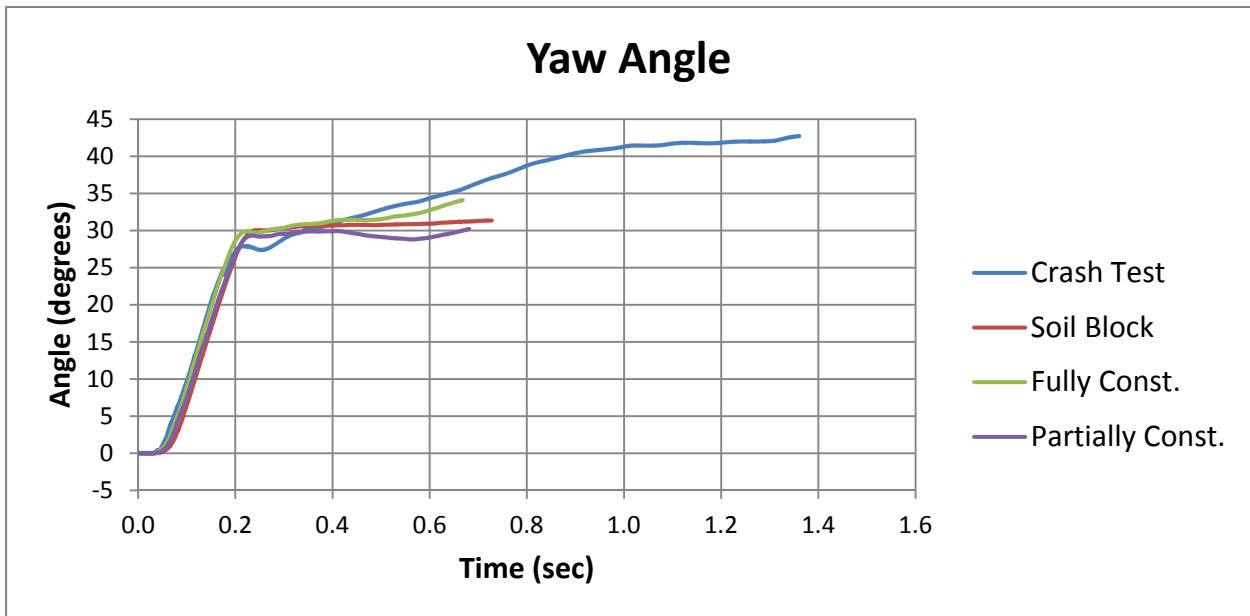
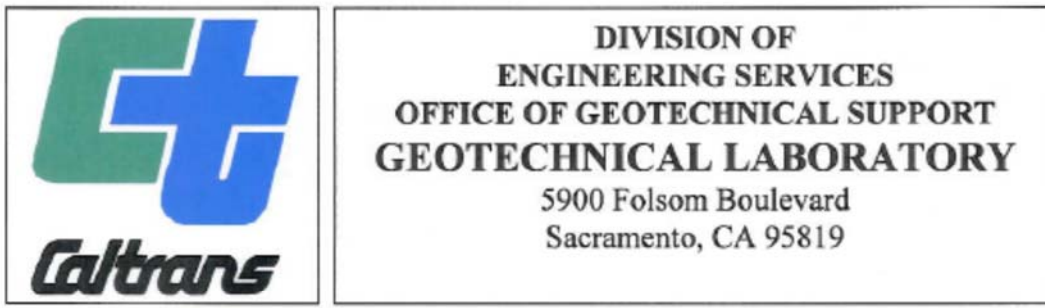

Figure 10-24 Comparing Crash Test and Simulation Yaw Angles

10.5.4 Conclusions

The interaction of a vehicle impacting roadside hardware is a complex scenario. To simulate this interaction in an FE model there has to be some simplifications to limit processing time and associated costs. None of the models cited in this report truly represented the actual crash test. Some elements in each simulation matched the real world counterpart. In one simulation, the TRAP results were similar to the real crash test's TRAP results but the vehicle movement was different. The other two simulations had TRAP results that were much higher than the real crash test's TRAP results but the movement of the vehicles were similar to that of the actual test vehicle. Improvements to the models will have to be made if they are going to be used in the future.

10.6 Soil Documentation



Date: 4/20/2012
To: Chris Caldwell / DRI
From: Lilibeth C. Purta / (916) 227-5239
RE: Laboratory Test Report -- EA: 65-680664
Project: 0000000740
GL 12-018

Final test results.

Note: All remaining test specimens will be disposed of in 30 calendar days from the release date of the final test results.





CALIFORNIA DEPARTMENT OF TRANSPORTATION
 GEOTECHNICAL LABORATORY

GL TRACKING NO : 12-018
 Dist - EA : 65-880664
 Report Date: April 20, 2012
 Page: 1/1

CLASSIFICATION TEST SUMMARY

SAMPLE ID	% FINER THAN													ATTERBERG LIMITS			AS RECEIVED		Gs			
	3"	2 1/2"	2"	1 1/2"	1"	3/4"	1/2"	3/8"	No. 4	No. 8	No. 16	No. 30	No. 50	No. 100	No. 200	5µ	1µ	LL		PI	Vd (pcf)	%fn
ALMGR_1-A							100	99	98	97	96	90	67	54	43	18	7	20	3			
ALMGR_1-B																						2.68

CONSOLIDATION TEST DATA

Project: Aesthetic Low Maint GR
 Boring No.: ALMGR
 Sample No.: 1-A
 Test No.: 12-091- G3

Location: -----
 Tested By: JG
 Test Date: 04/04/12
 Sample Type: 1.5" Tube

Project No.: 65-680664
 Checked By: *HP 4/10*
 Depth: 2
 Elevation: -----

Soil Description: moist, gray, stiff, silt/sand/clay
 Remarks:

Measured Specific Gravity: 2.68
 Initial Void Ratio: 0.49
 Final Void Ratio: 0.38

Liquid Limit: ---
 Plastic Limit: ---
 Plasticity Index: ---

Initial Height: 0.75 in
 Specimen Diameter: 1.94 in

Container ID	Before Consolidation		After Consolidation	
	Trimmings	Specimen+Ring	Specimen+Ring	Trimmings
		RING		
Wt. Container + Wet Soil, gm	99.2	99.2	102.7	102.7
Wt. Container + Dry Soil, gm	92.8	92.8	92.8	92.8
Wt. Container, gm	27.2	27.2	27.2	27.2
Wt. Dry Soil, gm	65.6	65.6	65.6	65.6
Water Content, %	9.76	9.76	15.09	15.09
Void Ratio	---	0.49	0.38	---
Degree of Saturation, %	---	53.29	105.57	---
Dry Unit Weight, pcf	---	112.26	121	---

CONSOLIDATION TEST DATA

Project: Aesthetic Low Maint GR
 Boring No.: ALMGR
 Sample No.: 1-A
 Test No.: 12-093- G3

Location: -----
 Tested By: JG
 Test Date: 04/04/12
 Sample Type: 1.5" Tube

Project No.: 65-680664
 Checked By:
 Depth: 2
 Elevation: -----

Soil Description: moist, gray, stiff, silt/sand/clay
 Remarks:

	Applied Stress tsf	Final Displacement in	Void Ratio	Strain at End %	T50 Fitting		Coefficient of Consolidation		
					Sq.Rt. min	Log min	Sq.Rt. in ² /sec	Log in ² /sec	Ave. in ² /sec
1	0.0625	0.002801	0.485	0.37	0.1	0.2	3.22e-003	2.53e-003	2.83e-003
2	0.125	0.005796	0.479	0.77	0.4	0.4	1.19e-003	1.26e-003	1.22e-003
3	0.5	0.01743	0.456	2.32	0.1	0.1	4.06e-003	4.49e-003	4.26e-003
4	1	0.02696	0.437	3.59	0.1	0.1	6.11e-003	6.37e-003	6.24e-003
5	2	0.03623	0.419	4.83	0.1	0.0	6.16e-003	9.38e-003	7.44e-003
6	4	0.0456	0.400	6.08	0.0	0.0	1.09e-002	0.00e+000	1.09e-002
7	8	0.05403	0.383	7.20	0.0	0.0	1.12e-002	2.27e-002	1.50e-002
8	16	0.06253	0.367	8.34	0.0	0.0	3.47e-002	2.76e-002	3.07e-002
9	4	0.06118	0.369	8.16	0.0	0.0	2.97e-002	0.00e+000	2.97e-002
10	0.25	0.05413	0.383	7.22	0.0	0.0	1.48e-002	1.57e-002	1.52e-002

CONSOLIDATION TEST DATA
 SUMMARY REPORT

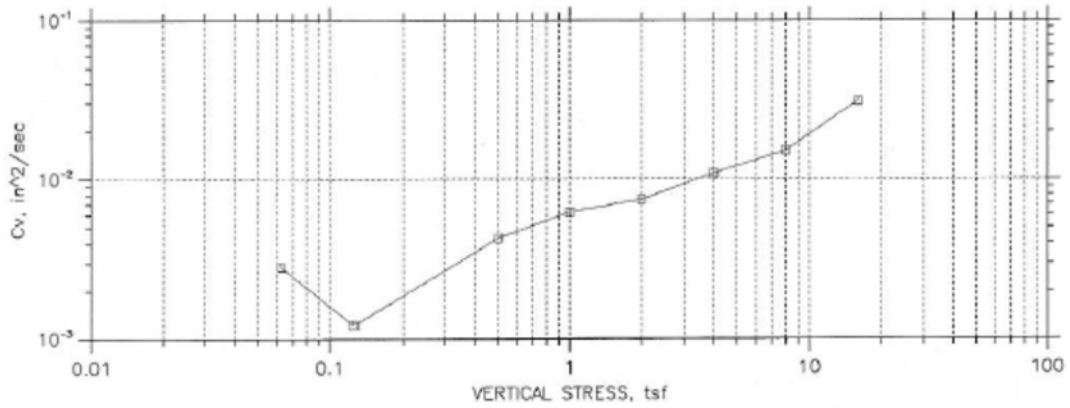
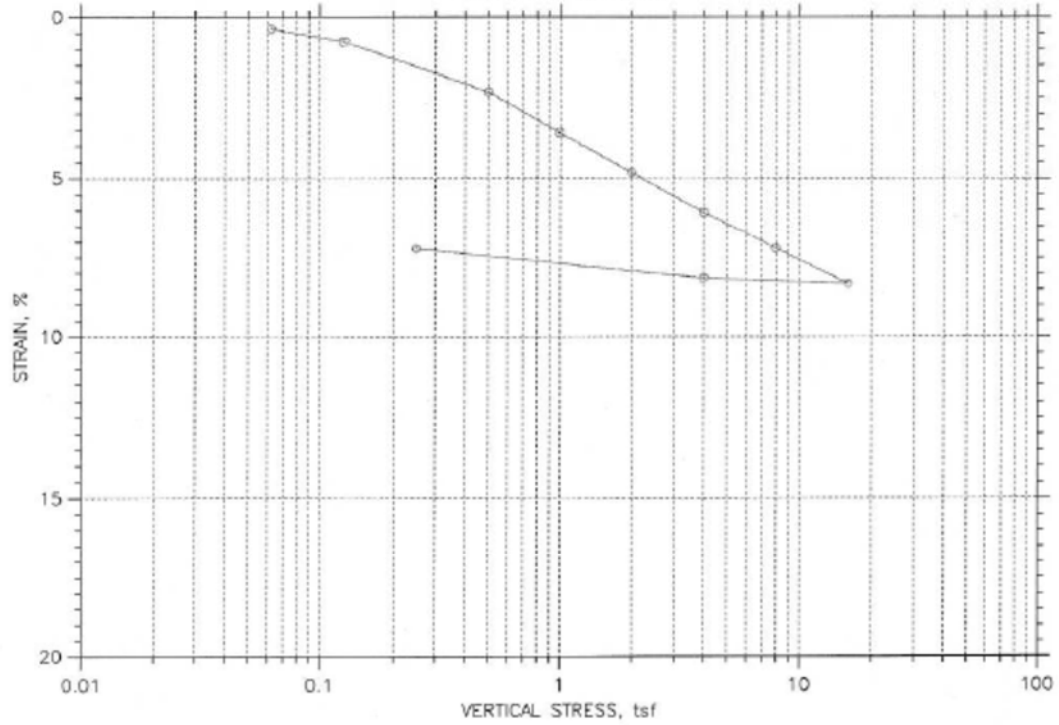

Project: Aesthetic Low Maint GR	Location: -----	Project No.: 65-680664
Boring No.: ALMGR	Tested By: JG	Checked By:
Sample No.: 1-A	Test Date: 04/04/12	Depth: 2
Test No.: 12-093- G3	Sample Type: 1.5" Tube	Elevation: -----
Description: moist, gray, stiff, silt/sand/clay		
Remarks:		

Thu, 19-APR-2012 15:07:11

CONSOLIDATION TEST DATA
 SUMMARY REPORT

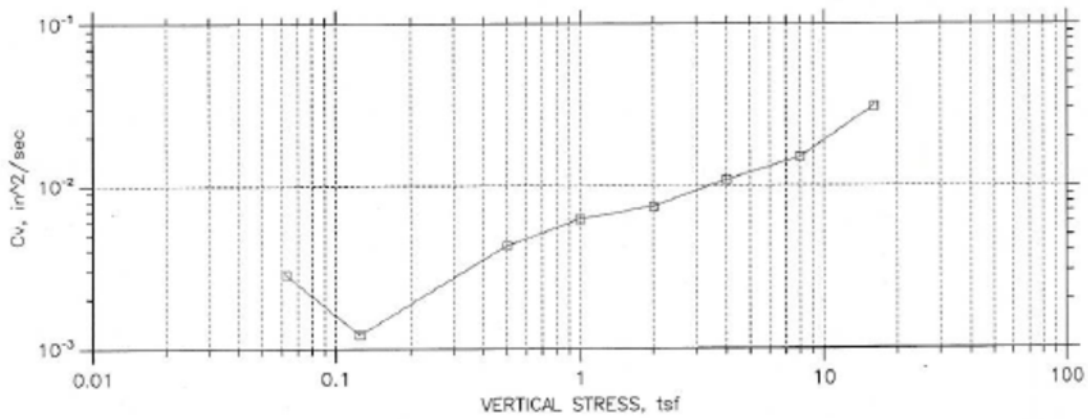
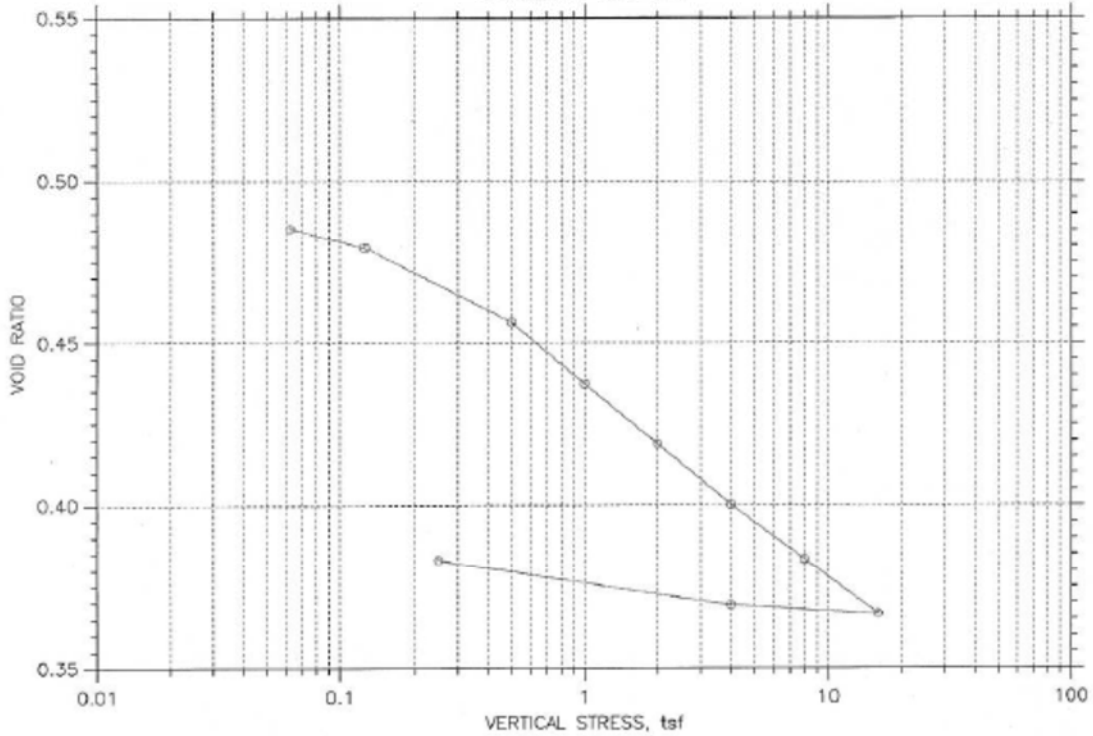

Project: Aesthetic Low Maint GR	Location: -----	Project No.: 65-680664
Boring No.: ALMGR	Tested By: JG	Checked By:
Sample No.: 1-A	Test Date: 04/04/12	Depth: 2
Test No.: 12-093- G3	Sample Type: 1.5" Tube	Elevation: -----
Description: moist, gray, stiff, silt/sand/clay		
Remarks:		

Thu, 19-APR-2012 15:07:52

CONSOLIDATION TEST DATA
 SUMMARY REPORT

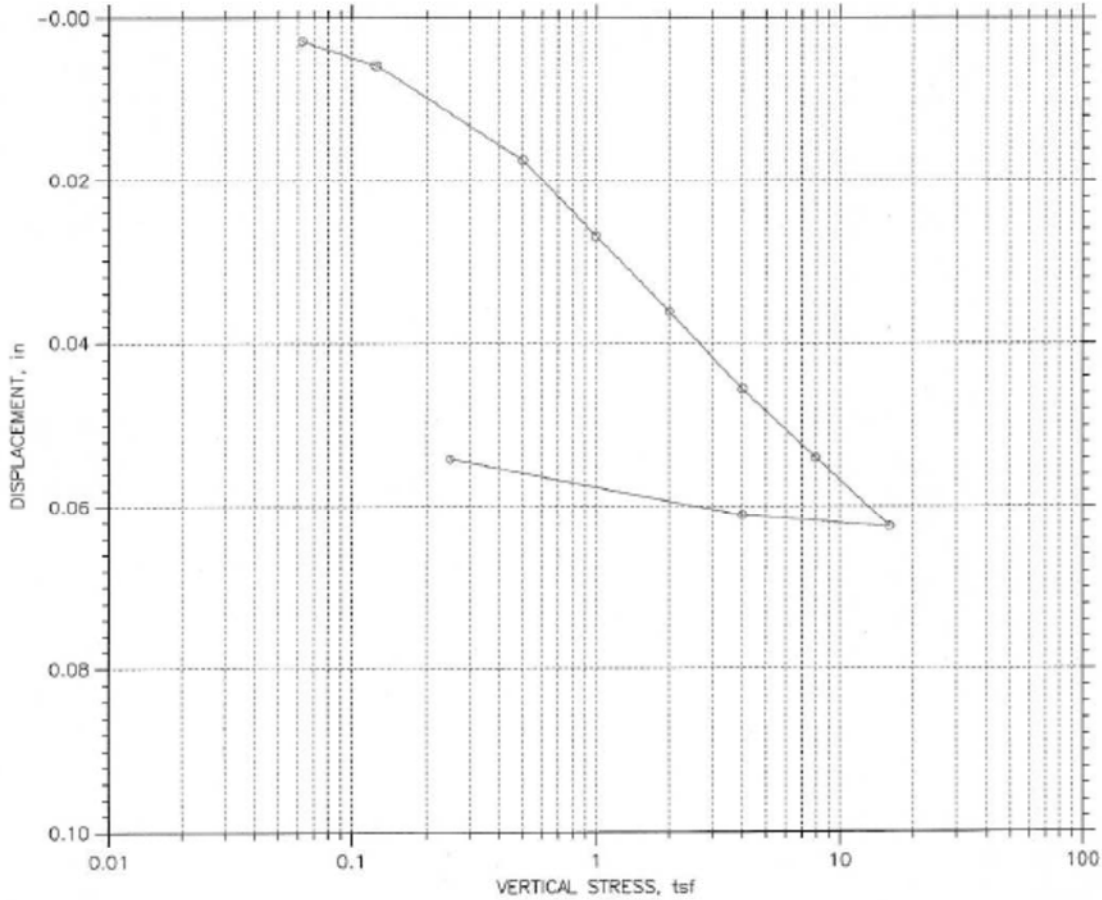

		Before Test	After Test	
Overburden Pressure: 8.864e-312 tsf		Water Content, %	9.76	15.09
Preconsolidation Pressure: 3.612e-311 tsf		Dry Unit Weight, pcf	112.3	121.
Compression Index: 2.75859e-313		Saturation, %	53.29	105.57
Diameter: 1.944 in	Height: 0.75 in	Void Ratio	0.49	0.38
LL: ---	PL: ---	PI: ---	GS: 2.68	

Project: Aesthetic Low Maint CR	Location: -----	Project No.: 65-680664
Boring No.: ALMCR	Tested By: JG	Checked By:
Sample No.: 1-A	Test Date: 04/04/12	Depth: 2
Test No.: 12-093- G3	Sample Type: 1.5" Tube	Elevation: -----
Description: moist, gray, stiff, silt/sand/clay		
Remarks:		

Thu, 19-APR-2012 15:08:33

UNCONSOLIDATED UNDRAINED TRIAXIAL TEST by ASTM D2850

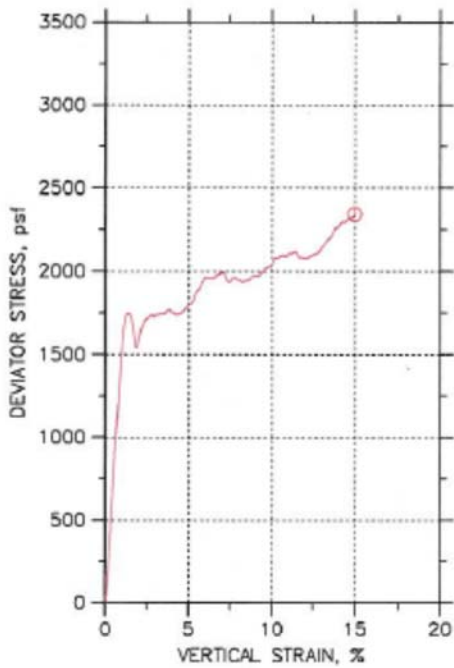
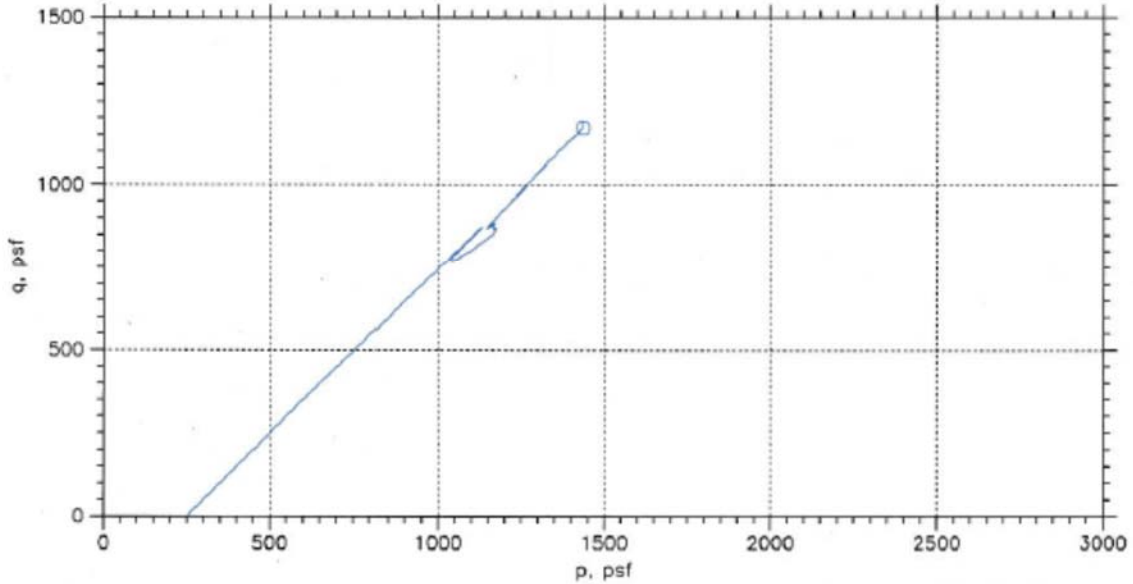

Symbol	⊙	
Sample No.	1-A	
Test No.	U12-003	
Depth	2	
Initial	Diameter, in	2.8
	Height, in	6
	Water Content, %	9.8
	Dry Density, pcf	110.7
	Saturation, %	49.1
	Void Ratio	0.55
Before Shear	Water Content, %	
	Dry Density, pcf	
	Saturation, %	
	Void Ratio	
	Back Press., psf	
	Ver. Eff. Cons. Stress, psf	250.6
	Shear Strength, psf	1171
	Strain at Failure, %	15
	Strain Rate, %/min	1
	B-Value	---
	Implied Specific Gravity	2.75
	Liquid Limit	---
	Plastic Limit	---



	Project: Aesthetic Low-Maint. GR	
	Location: 04-SF-1-6.0-9.7	
	Project No.: 65-680664	
	Boring No.: ALMGR	
	Sample Type: SHELBY	
	Description: Damp, Firm, Brown, Clayey Silty Soil. Remolded to 90% RC @ Optimum MC	
Remarks: GL NO. 12-007. Sample description is not a soil classification.		11/4/19

UNCONFINED COMPRESSION TEST REPORT

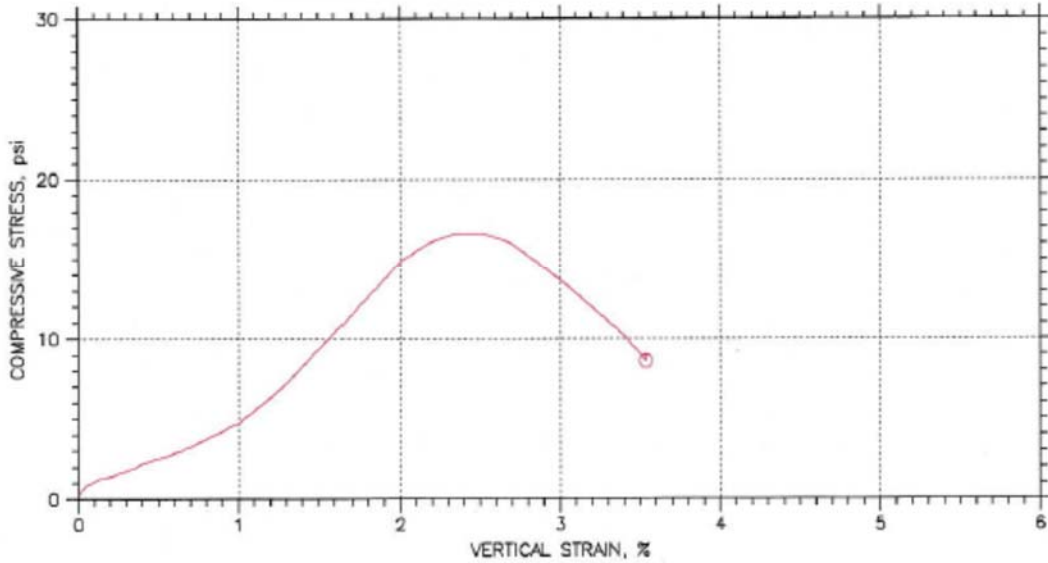

Symbol	⊙	
Test No.	Q12-011	
Initial	Diameter, in	2.8
	Height, in	6
	Water Content, %	9.70
	Dry Density, pcf	110.6
	Saturation, %	
	Void Ratio	
Unconfined Compressive Strength, psi	16.64	
Undrained Shear Strength, psi		
Time to Failure, min		
Strain Rate, %/min	1	
Implied Specific Gravity		
Liquid Limit	---	
Plastic Limit	---	
Plasticity Index	---	
Failure Sketch		



	Project: AESTHETIC LOW-MAINT.
	Location:
	Project No.: 65-680664
	Boring No.: ALMGR
	Sample No.: 1-A
	Description: MOIST, BROWN SILTY CLAY
	Remarks: ASTM D 2166. REMOLDED

11/4/19

DIRECT SHEAR TEST REPORT

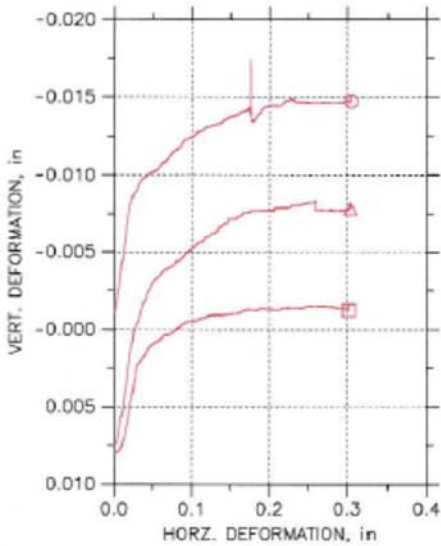
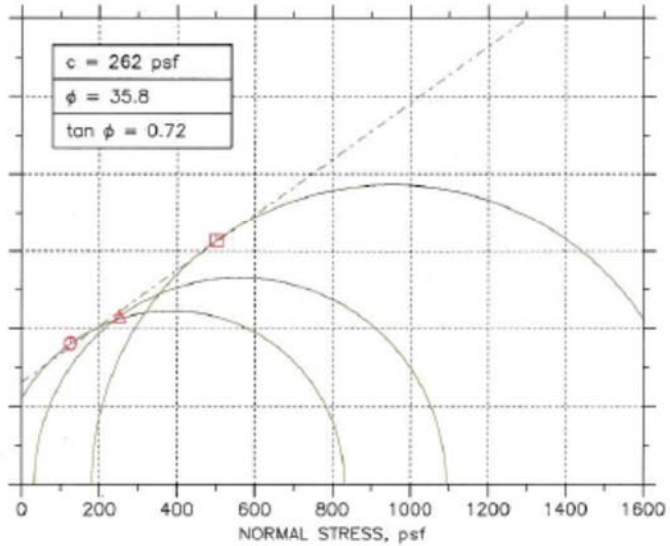
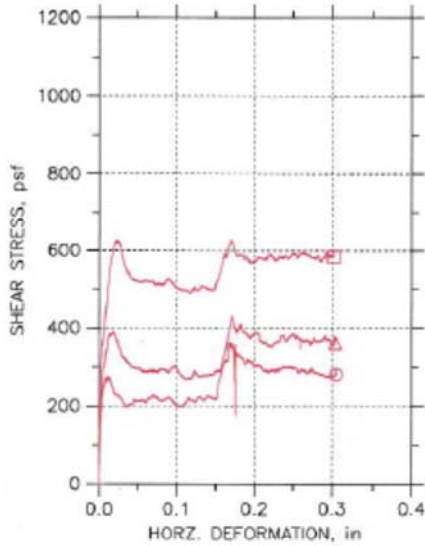

Symbol	○	△	□	
Test No.	DS12010A	DS12010B	BDS12010C	
Sample No.	1-B	1-B	1-B	
Shape	Circular	Circular	Circular	
Initial	Dimension, in	1.94	1.94	1.94
	Area, in ²	2.9559	2.9559	2.9559
	Height, in	1	1	1
	Water Content, %	9.20	9.46	9.46
	Dry Density, pcf	109.29	109.03	109.03
	Saturation, %	45.80	46.77	46.77
Void Ratio	0.54228	0.54592	0.54592	
Consol. Height, in	0.99942	0.99288	0.99214	
Consol. Void Ratio	0.54138	0.53492	0.53377	
Final	Water Content, %	18.75	18.44	18.44
	Dry Density, pcf	107.71	108.19	108.9
	Saturation, %	89.61	89.22	90.88
	Void Ratio	0.56493	0.55801	0.54784
Normal Stress, psf	125.93	251.87	501.11	
Max. Shear Stress, psf	360.83	430.37	627.18	
Ult. Shear Stress, psf	279.48	360.83	583.88	
Time to Failure, min	35.143	35.865	35.28	
Disp. Rate, in/min	0.005	0.005	0.005	
Implied Specific Gravity	2.70	2.70	2.70	
Liquid Limit	---	---	---	
Plastic Limit	---	---	---	
Plasticity Index	---	---	---	

Project: Aesthetic Low-Maint GR	
Location:	
Project No.: 65-680664	
Boring No.: ALMGR	
Sample Type: REMOLD	
Description: Damp, Firm, Brown, Silty Soil with Clay. Remolded to 90% RC @ Optimum MC	
Remarks: ASTM D 3080.	

DIRECT SHEAR
JOB : 65-680664
SAMPLE : ALMGR_1-B
Test Specimen A



DIRECT SHEAR
JOB : 65-680664
SAMPLE : ALMGR_1-B
Test Specimen B



DIRECT SHEAR
JOB : 65-680664
SAMPLE : ALMGR_1-B
Test Specimen C





Division of Engineering Services
Geotechnical Laboratory

Compaction Curve

CTM 216

Dist-EA: 65-680664 Maximum Dry Density: 123.1 pcf
 Dist-Co-Rte-PM: -/- Optimum Moisture: 9.7 %
 Sample ID: ALMGR_1-A Moisture (as Received): 9.2 %
 GI Tracking No.: 12-018 Approved: March 23, 2012

Trial No.	Moisture Adjustment	Tamper Reading	Wet + Tare Weight (g)	Dry + Tare Weight (g)	Tare (g)	Moisture Content (%)	Dry Unit Weight (pcf)
1	100	10.70	3057	2925	743	6.0	120.0
2	200	10.45	3198	2982	795	9.9	123.1
3	300	10.90	3310	2998	810	14.3	118.1
4							
5							
6							

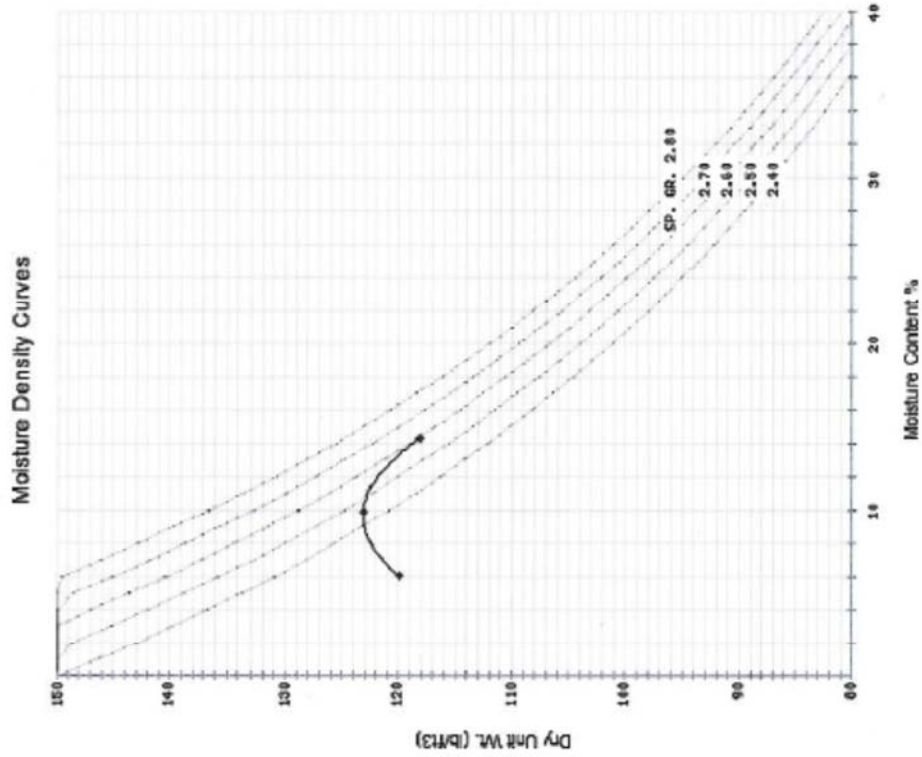

Soil Description : BROWN SILT

Remarks:

10.7 Concrete Certification Documentation

SYAR CONCRETE LLC
 P.O. BOX 2700 NAPA,
 CA 94558
 (877) SYARMIX

Concrete Mix Design Submittal

DATE: 06/18/2012 No. 061226 Version 1

Mix Code CT063CR5W

Customer	R A NEMETZ CONSTRUCTION CO INC	Design Strength	4000 PSI @ 42 DAYS
		W/CM Ratio	0.45
Project Name	CHP ACADEMY - WEST SACRAMENTO	Slump	4 +/- 1"
Usage/Placement	CLASS 2 CONCRETE - Test Rail	Air Content	1.50 +/- 1.5%
		Unit Weight	151.11 lb/ft ³

SYAR CONCRETE LLC has no authority regarding the appropriate application of the mix design. It is the responsibility of the owner's representative and or contractor to insure that this mix design is appropriate for the intended use and environmental conditions for the intended application of the mix. This concrete mix design will meet design strengths when tested in strict compliance with current ASTM Standard and evaluated in accordance with ACI standard practices. Approval of the mix design carries the inclusion of SYAR CONCRETE LLC on the distribution list for all concrete test results. Cementitious content is expressed as a minimum and SYAR CONCRETE LLC reserves the right to increase the total cementitious content. Admixtures are dosed as per manufactures recommendations and may be adjusted to maintain mix design properties. Aggregate weights may be adjusted to maintain proper yield and to comply with grading specifications.
 It is the responsibility of the contractor to verify pumpability with the pumping contractor.

Material Type	Description	Design Quantity	Specific Gravity	Volume (ft ³)
Cement	CEMENT TYPE II / V MODIFIED	445.0 lb	3.15	2.26
Fly Ash	FLY ASH / CLASS F	150 lb	2.30	1.05
Course Aggregate	ASTM C33 / 1" X #4 COARSE AGGREGATES	1850 lb	2.77	10.70
Fine Aggregate	ASTM C33 / CONCRETE SAND	1368 lb	2.64	8.30
Water	WATER	32.0 gal	1.00	4.28
Admixture	TYPE A WATER REDUCER	24 lq oz	-	-
	Air Content	1.50 %	-	0.40
	Yield	4080 lb	-	27.00

NOTES

Prepared By:

 Robert Hightower Technical Services

Concrete Mix Design Submittal

DATE: 06/18/2012

No. 061226 Version 1

Mix Code	CT063CR5W
-----------------	------------------

Workability Factor 37.3 Total Agg FM 5.14
 Adj. Workability Factor 38.1 Coarseness Factor 74.2

Sieve Size	Course 031110 % Passing	Fine 031200 % Passing	Combined % Passing
1 1/2	100.0	100.0	100.0
1	100.0	100.0	100.0
3/4	83.0	100.0	90.2
1/2	50.0	100.0	71.3
3/8	20.0	100.0	54.0
No. 4	4.0	100.0	44.8
No. 8	1.0	81.0	35.0
No. 16		55.0	23.4
No. 30		35.0	14.9
No. 50		18.0	7.7
No. 100		7.0	3.0
No. 200		3.0	1.3
% Agg	57.5	42.5	
SG	2.77	2.64	
DRUW lb/ft ³	109.40		
FM		3.07	5.14

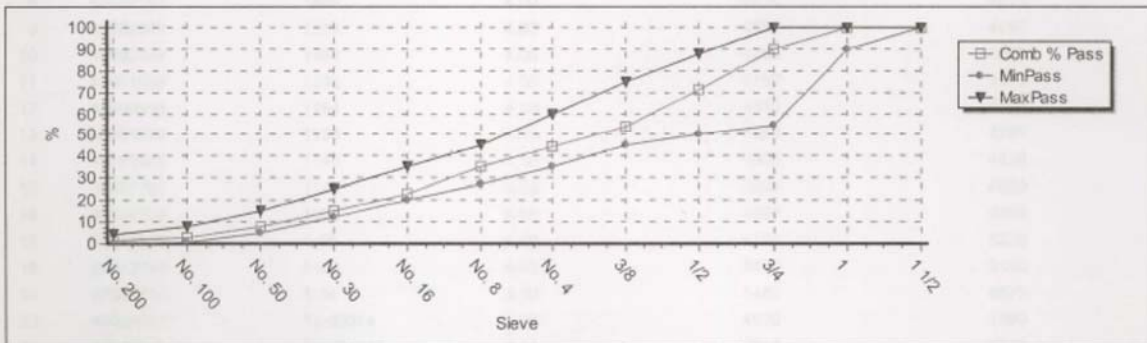

ACI Statistical Report
 CT063CR5W

Number of 28D Tests	30	CoV 28 Day Strength	6.8 %
Average 28D Strength	4660	ACI Running Average of 3 Criteria	YES
ACI 318 5.3.2 Req. Avg. Strength	4420	ACI 318 Standard Deviation Criteria	YES
Specified Strength	4000	Adjusted SD Per ACI 318 5.3.1.2	314.9

	Concrete Temp deg F	Slump in	28D STR psi	28D Last3 psi
Max	88	5.00	5480	5220
Min	50	3.00	4110	4290
Count	17	29	30	28
Mean	64	4.15	4660	4640
SD	9	0.50	314.9	233.2
CoV%	14	12.01	6.8	5.0

Ticket	Sample	Slump in	28D STR psi	28D Last3 psi	
1	88031056	1038	4.25	4900	4890
2	87013902	SAC25813	3.00	5120	4780
3	46008168	SAC25771	4.50	4640	4630
4	46006900	2803	4.00	4570	4580
5	46006654	2581	4.00	4670	4420
6	46005953	1801	4.00	4490	4340
7	45002301	1597	4.00	4110	4400
8	45002129	1446	4.00	4410	4610
9	45002049	1358	4.00	4680	4740
10	45002039	1350	4.00	4750	4630
11	45001983	1288	4.00	4780	4470
12	48009558	1154	4.00	4350	4310
13	45001839	1138	4.00	4280	4290
14	45001866	1146	4.00	4300	4430
15	45001761	1142	4.00	4290	4580
16	45001723	1058	4.00	4690	4950
17	89017898	1-50	4.50	4770	5220
18	87012744	1-28	4.00	5400	5140
19	87012714	1-24	3.00	5480	4870
20	46004054	11-00044	5.00	4530	4590
21	87012353	SAC24918	4.00	4610	4570
22	87012260	1-16	4.50	4630	4510
23	87012268	1-20	4.50	4470	4450
24	46003601	46003601	5.00	4440	4600
25	46003601	SAC24914	5.00	4440	4650
26	46003571	SAC24908	4.00	4930	4780
27	46003586	SAC24909	4.50	4580	4690
28	87012202	1-12	3.50	4840	4860
29	46003519	SAC24904	5.00	4660	
30	46003507	SAC24901	4.00	5080	



9350 OAK CREEK ROAD, MOJAVE, CALIFORNIA 93501 / TEL. (661) 832 3700, FAX (661) 824-4908

Manufacturer's Certification

We hereby certify that This Type II/V Low Alkali cement, sourced from U.S. CA. Mojave, supplied to you has been manufactured in accordance with and meets the standard requirements of ASTM C 150 specification for TYPE II and TYPE V cement. Additionally, this Type II/V cement meets the requirements of Caltrans Standard Specifications Sec. 90 paragraph 2.01. Following are the average chemical and physical data from **April 5, 2012 to April 30, 2012:** Report Date: May 15, 2012

Chemical Analysis	ASTM C150 Requirements			MOJAVE TYPE II/V	Additional Data
	TYPE II Requirements	TYPE V Requirements			
					Limestone Analysis
Silicon dioxide (SiO ₂), min,%	---	---		20.8	4.5
Aluminum oxide (Al ₂ O ₃), max,%	6.0	---		3.4	1.4
Ferric oxide (Fe ₂ O ₃), max,% (Note 2)	6.0		M	3.8	0.6
Calcium Oxide (CaO), %					50.7
Magnesium oxide (MgO), max,%	6.0	6.0		2.2	2.7
Sulfur trioxide (SO ₃), max,%; (Note 1)	3.0	2.3		2.8	0.2
Loss on ignition, max,%	3.0	3.0		2.6	
Insoluble residue, max,%	0.75	0.75		0.51	Base Cement Phase
Alkalies(Na ₂ O+0.658*K ₂ O), max.%	0.60	0.60		0.51	Composition
Tricalcium silicate (C3S), % (Note 5)	---	---	O	54	56
Dicalcium silicate (C2S), %	---	---		19	19
Tricalcium aluminate (C3A), max,%; (Note 2)	8	5		2	3
Tetracalcium aluminoferrite (C4AF), %	---	---		12	12
C4AF + 2*(C3A), max,%; (Note 2)	---	25		16	
CO ₂ , %	---	---	J	1.3	
limestone, max,%	5.0	5.0		3.3	II
CaCO ₃ in limestone, min, %	70	70		92.9	
Physical Data					
Air content of mortar,max,%	12	12		7	
Passing 45um (no. 325) sieve, %	---	---	A	98.2	V
Blaine Fineness, min, m ² /kg;	280/---	280/---		423	
Heat of Hydration, C186, (cal/g). (Note 3)	---	---		77	
Autoclave expansion, max,% (Note 4)	0.80	0.80		-0.01	
Compressive Strength, min, MPa, (psi)			V		
3 days	10.0	8.0		21.8	
	(1450)	(1160)		(3160)	
7 days	17.0	15.0		28.5	
	(2470)	(2180)		(4130)	
28 days *(from previous month)	---	*21.0		*41.5	
	---	*(3050)		*(6030)	
Vicat, initial set, min.-max., minutes	45-375	45-375	E	140	
C 1038, 14 day max, % expansion (Note 1)	0.020	0.020		0.010	
C 452, 14 day max, % expansion (Note 2)	---	0.040		0.028	
False Set, final penetration, min,%	50	50		79	

Apparatus and methods used in this laboratory have been checked by the Cement and Concrete Reference Laboratory of the National Institute of Standards and Technology. A copy of the report detailing their findings is available upon request. Major Oxides are analyzed by X-ray Fluorescence Spectrometry.

- Note 1: ASTM C150, Table 1, Note D. It is permissible to exceed the values in the table for SO₃ content, provided it has been demonstrated by Test Method C1038 that the cement with the increased SO₃ will not develop expansion exceeding 0.020% at 14 days.
- Note 2: ASTM C150, Table 1, Note B. Does not apply when the optional sulfate resistance limit in Table 4 is specified.
- Note 3: ASTM C150, Table 1, Note H: For Informational Purposes Only
- Note 4: Caltrans Specification Sec. 90, paragraph 2.01A. The autoclave expansion shall not exceed 0.50%.
- Note 5: Caltrans Specification Sec. 90, paragraph 2.01A. Type II cement C₃S content shall not exceed 65%.

Charles T. Wright Jr.

Charles T. Wright Jr. - Quality Control Superintendent



Adding Value to Energy™

ASTM C618 Testing of
 Stockton Terminal Fly Ash

Sample Type:	3200-ton	Report Date:	5/18/2012
Sample Date:	2/22 - 3/12/12	MTRF ID:	658ST
Sample ID:	ST-003-12		

Chemical Analysis	ASTM Limits		ASTM Test Method
	Class F	Class C	
Silicon Dioxide (SiO ₂)	59.37 %		
Aluminum Oxide (Al ₂ O ₃)	18.65 %		
Iron Oxide (Fe ₂ O ₃)	4.78 %		
Sum of Constituents	82.80 %	70.0% min 50.0% min	D4326
Sulfur Trioxide (SO ₃)	0.91 %	5.0% max 5.0% max	D4326
Calcium Oxide (CaO)	7.81 %		D4326
Moisture	0.14 %	3.0% max 3.0% max	C311
Loss on Ignition	1.11 %	6.0% max 6.0% max	C311

Physical Analysis

Fineness, % retained on #325	16.49 %	34% max	34% max	
Fineness Uniformity	0.49 %	5% max	5% max	
Strength Activity Index - 7 or 28 day requirement				C311, C430
7 day, % of control	85 %	75% min	75% min	
28 day, % of control	94 %	75% min	75% min	
Water Requirement, % control	97 %	105% max	105% max	C311, C109
Autoclave Soundness	0.01 %	0.8% max	0.8% max	
Density	2.37			
Density Uniformity	2.70 %	5% max	5% max	C311, C151
				C604

Headwaters Resources certifies that pursuant to current ASTM C618 protocol for testing, the test data listed herein was generated by applicable ASTM methods and meets the requirements of ASTM C618 for Class F fly ash.

Bobby Bergman
 Bobby Bergman
 MTRF Manager



Materials Testing & Research Facility
 2650 Old State Highway 113
 Taylorsville, Georgia 30176
 P: 770.684.0102
 F: 770.684.5114

Trial Batch 3 -Point Curve As Per ACI 318

Western Aggregates

Materials

Cement	ASTM C-150 Type II / V
Fly Ash	ASTM C-618 / Class F
Coarse Aggregate	ASTM C-33 Size #57 / 1850 LBS
Fine Aggregate	ASTM C-33 Concrete Sand
Admix	ASTM C494 / Type A

Mix Data

Cement lbs/cy	415	443	506	565
Fly Ash lbs/cy	140	148	169	185
Total Cementitious lbs/cy	555	590	675	750
Water lbs/cy	267	267	267	270
W/C Ratio	0.48	0.45	0.40	0.36
7 Day Average of 3	3120	3510	4120	4750
28 Day Average of 3	5080	5290	5870	6300

Compressive Strength by Water-Cementitious Ratio

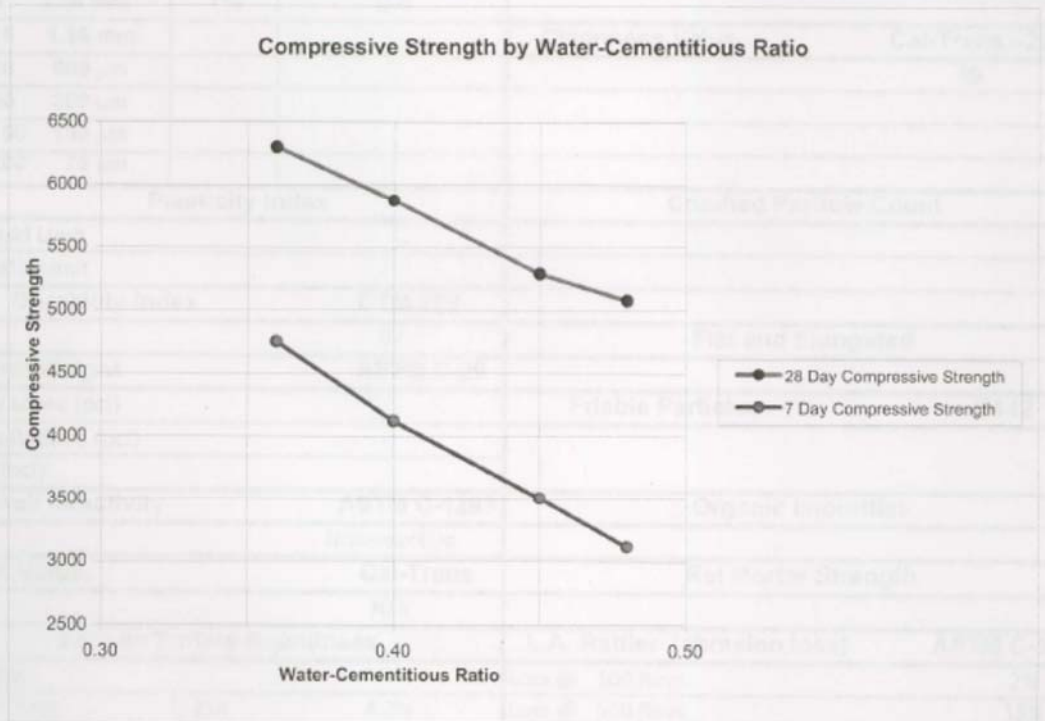

MATERIAL EVALUATION				
PRODUCT: <u>1" x #4 Concrete Rock</u>		DATES FROM: <u>1.1.12</u>		
SAMPLED BY: <u>Western Aggregates</u>		TO: <u>5.31.12</u>		
TESTED BY: <u>Western Aggregates</u>		SAMPLED FROM: <u>stockpile</u>		
Sieve Size	Percent Passing	Spec Cal Trans	Specific Gravity	ASTM C-128
3"			Bulk Dry	
2 1/2"			Bulk SSD	2.80
2"			Apparent	2.89
1 1/2"	100%	100	Moisture	ASTM C-566
1" 25 mm	100%	88-100	Total Moisture	
3/4" 19 mm	91%	x=83 68-98	Absorption	
1/2" 12.5 mm	50%		Sand Equivalent	ASTM D-2419/Cal-Trans
3/8" 9.5 mm	24%	x=20 5-35		N/A
#4 4.75 mm	4%	0-16	Fineness Modulus	ASTM C-33
#8 2.36 mm	1%	0-6		
#16 1.18 mm			Cleanness Value	Cal-Trans - 227
#30 600 μm				89
#50 300 μm				
#100 150 μm				
#200 75 μm				
Plasticity Index		Crushed Particle Count		
Liquid Limit				
Plastic Limit				
Durability Index		CTM 229		
		67		
Unit Weight		ASTM C-29		
Dry Loose (pcf)		Flat and Elongated		
Dry Rodded (pcf)		Friable Particles		
Jig (pcf)		C142		
Alkali Reactivity		ASTM C-1293		
		Non-reactive		
R Value		Cal-Trans		
		N/A		
Sodium Sulfate Soundness		L.A. Rattler (abrasion loss)		
ASTM		ASTM C-131		
		Loss @ 100 Revs. 2%		
Cal-Trans C-214		Loss @ 500 Revs. 13%		
		4.2%		

MATERIAL EVALUATION				
PRODUCT: <u>Concrete Sand</u>		DATES FROM: <u>1.1.12</u>		
(ASTM C-33)				
SAMPLED BY: <u>Western Aggregates</u>		TO: <u>5.31.12</u>		
TESTED BY: <u>Western Aggregates</u>		SAMPLED FROM: <u>stockpile</u>		
Sieve Size	Percent Passing	Spec: C-33	Specific Gravity	ASTM C-128
3"			Bulk Dry	2.565
2 1/2"			Bulk SSD	2.632
2"			Apparent	2.774
1 1/2"			Moisture	ASTM C-566
1" 25 mm			Total Moisture	7.30%
3/4" 19 mm			Absorption	2.60%
1/2" 12.5 mm			Sand Equivalent	ASTM D-2419/Cal-Trans
3/8" 9.5 mm	100%	100		81.0
#4 4.75 mm	100%	95 to 100	Fineness Modulus	ASTM C-33
#8 2.36 mm	83%	80-100		2.96
#16 1.18 mm	58%	50-85	Cleanness Value	Cal-Trans
#30 600 μm	37%	25-60		
#50 300 μm	19%	5 to 30		
#100 150 μm	8%	0 to 10		
#200 75 μm	3%			
Plasticity Index		Crushed Particle Count		
Liquid Limit	0.00	1 Face		
Plastic Limit	non-plastic	2 Face		
Durability Index	ASTM D-3744	3 Face		
	48	Flat and Elongated		
Unit Weight	ASTM C-29			
Dry Loose (pcf)	83.60	Friable Particles		
Dry Rodded (pcf)	87.86			
Jig (pcf)	97.34			
Alkali Reactivity	ASTM C-1567	Organic Impurities ASTM C40, C87		
	Innocuous	Negative		
"R" Value	Cal-Trans	Rel Mortar Strength		
	N/A	95%		
Sodium Sulfate Soundness	ASTM C-88	L.A. Rattler (abrasion loss)		ASTM C-131
ASTM	2.58%	Loss @ 100 Revs.		
Cal-Trans	2.58%	Loss @ 500 Revs.		



The Chemical Company

3	03 30 00	Product Data Cast-in-Place Concrete Precast Concrete Mass Concrete
	03 40 00	
	03 70 00	

Description

Pozzolith 322 N ready-to-use, liquid admixture is used for making more uniform and predictable quality concrete. It meets ASTM C 494/C 494M requirements for Type A water-reducing, Type B retarding, and Type D retarding and water-reducing admixtures.

Applications

Recommended for use in:

- Prestressed concrete
- Precast concrete
- Reinforced concrete
- Shotcrete
- Lightweight or standard weight concrete
- Pumped concrete
- 4x4™ Concrete
- Pervious Concrete
- Rheodynamic® Self-Consolidating Concrete (SCC)

POZZOLITH® 322 N

Water-Reducing Admixture

Features

- Reduced water content required for a given workability
- Normal setting characteristics

Benefits

- Improved workability
- Reduced segregation
- Superior finishing characteristics for flatwork and cast surfaces
- Increased compressive and flexural strength

Performance Characteristics

Mix Data: 400 lb/ycd³ (237 kg/m³) of Type I cement; slump 5 inches (125 mm); non-air-entrained concrete; concrete temperature 76 °F (24 °C); ambient temperature 74 °F (23 °C).

Setting Time

Mix Design	Initial Set (h:min)	Difference (h:min)
Plain Concrete	5:20	REF
Pozzolith 322 N admixture @		
3 fl oz/cwt (195 mL/100 kg)	5:15	-0:05
5 fl oz/cwt (325 mL/100 kg)	5:40	+0:20
7 fl oz/cwt (460 mL/100 kg)	6:20	+1:00

Compressive Strength

Mix Design	7 Days			28 Days		
	psi	MPa	%	psi	MPa	%
Plain Concrete	2150	14.8	100	3070	21.2	100
Pozzolith 322 N admixture @						
3 fl oz/cwt (195 mL/100 kg)	2820	19.4	131	3970	27.4	129
5 fl oz/cwt (325 mL/100 kg)	3160	21.8	147	4100	28.3	134
7 fl oz/cwt (460 mL/100 kg)	3190	22.0	148	4390	30.3	143

Note: The data shown is based on controlled laboratory tests. Reasonable variations from the results shown here may be experienced as a result of differences in concrete-making materials and jobsite conditions.

Setting time of concrete is influenced by the chemical and physical composition of the basic ingredients of the concrete, the temperature of the concrete and the climactic conditions. Trial mixes should be made with job site materials to determine the dosage required for specified setting time and a given strength requirement.



Guidelines for Use

Dosage: Pozzolith® 322 N admixture is recommended for use within a range of 3-7 fl oz/cwt (195-460 mL/100 kg) of cement for most concrete mixtures using average concrete ingredients. Because of variations in job conditions and concrete materials, dosages other than the recommended amounts may be required. In such cases, contact your local BASF Construction Chemicals representative.

Product Notes

Corrosivity – Non-Chloride, Non-Corrosive: Pozzolith 322 N admixture will neither initiate nor promote corrosion of reinforcing steel in concrete. This admixture does not contain intentionally-added calcium chloride or other chloride-based ingredients.

Compatibility: Pozzolith 322 N admixture may be used in combination with any BASF Construction Chemicals admixtures. When used in conjunction with other admixtures, each admixture must be dispensed separately into the mix.

Storage and Handling

Storage Temperature: If Pozzolith 322 N admixture freezes, thaw at temperatures above 35 °F (2 °C) and completely reconstitute by mild mechanical agitation. **Do not use pressurized air for agitation.**

Shelf Life: Pozzolith 322 N admixture has a minimum shelf life of 18 months. Depending on storage conditions, the shelf life may be greater than stated. Please contact your BASF Construction Chemicals representative regarding suitability for use and dosage recommendations if the shelf life of Pozzolith 322 N admixture has been exceeded.

Packaging

Pozzolith 322 N admixture is supplied in 55 gal (208 L) drums, 275 gal (1040 L) totes and by bulk delivery.

Related Documents

Material Safety Data Sheets: Pozzolith 322 N admixture.

Additional Information

For additional information on Pozzolith 322 N admixture, contact your BASF Construction Chemicals representative.

The Admixture Systems business of BASF Construction Chemicals is a leading provider of innovative additives for specialty concrete used in the ready mix, precast, manufactured concrete products, underground construction and paving markets throughout the NAFTA region. The Company's respected Master Builders brand products are used to improve the placing, pumping, finishing, appearance and performance characteristics of concrete.

BASF Construction Chemicals, LLC
Admixture Systems

www.masterbuilders.com

United States 23700 Chagrin Boulevard, Cleveland, Ohio 44122-5544 ■ Tel: 800 628-9990 ■ Fax: 216 639-8821

Canada 1800 Clark Boulevard, Brampton, Ontario L6T 4M7 ■ Tel: 800 387-5862 ■ Fax: 905 792-0651

© Construction Research & Technology GmbH

© BASF Construction Chemicals, LLC 2007 ■ Printed in USA ■ 03/07 ■ LIT # 1016972

**Master
Builders**