

**DEPARTMENT OF TRANSPORTATION**  
**ENGINEERING SERVICE CENTER**  
Transportation Laboratory  
5900 Folsom Boulevard  
Sacramento, California 95819-4612



## METHOD OF TEST FOR PERMEABILITY OF SOILS

**CAUTION:** Prior to handling test materials, performing equipment setups, and/or conducting this method, testers are required to read **“SAFETY AND HEALTH”** in Section I of this method. It is the responsibility of the user of this method to consult and use departmental safety and health practices and determine the applicability of regulatory limitations before any testing is performed.

### PART I. CONSTANT-HEAD PERMEABILITY TEST METHOD

#### A. SCOPE

The permeability test is a measure of the rate of the flow of water through soil.

In this test, water is forced by a known constant pressure through a soil specimen of known dimensions and the rate of flow is determined. This test is used primarily to

determine the suitability of sands and gravels for drainage purposes, and is made only on remolded samples. The test is limited to materials which have a coefficient of permeability of approximately 300 mm/day or greater. The “Constant Head” type of test is used on samples that represent materials to be used as backfill for abutments, as permeable material for underdrains, as sand drains, as sand blanket for sand drain areas, and similar materials.

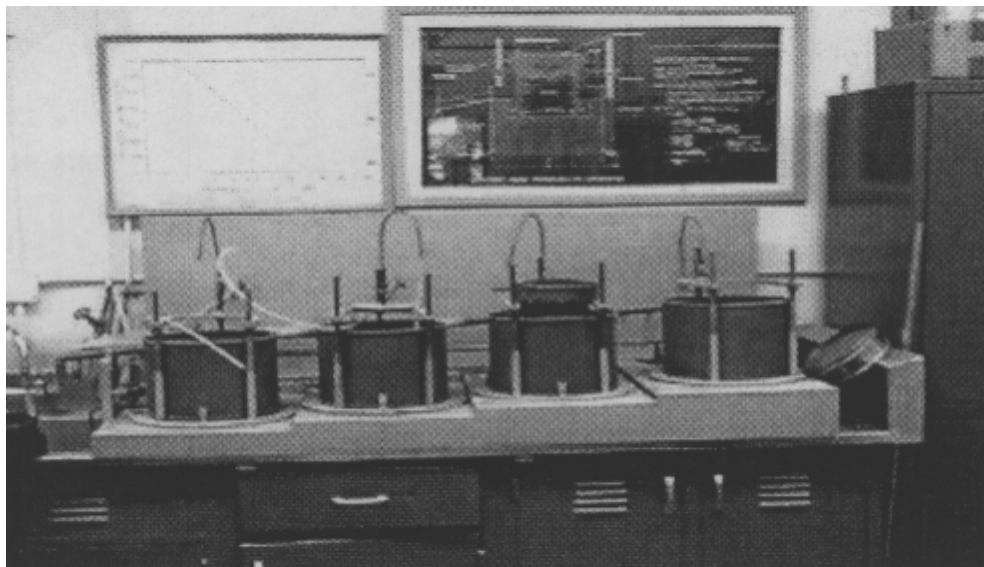

FIGURE 1 - CONSTANT-HEAD PERMEABILITY APPARATUS

**B. APPARATUS**

1. The permeability equipment is shown in Figures 1, 2, and 3.
2. The compaction hammer and leveling piston are shown in Figure 4.
3. Other laboratory equipment, not shown, includes:
  - a. 'Hobart' soil mixer.
  - b. Top-loading scale, 15 kg capacity.
  - c. Scoop.
  - d. Stop watch or timer.
  - e. Depth gauge.
  - f. Moisture pans.
  - g. Drying oven.
  - h. Domestic water supply.

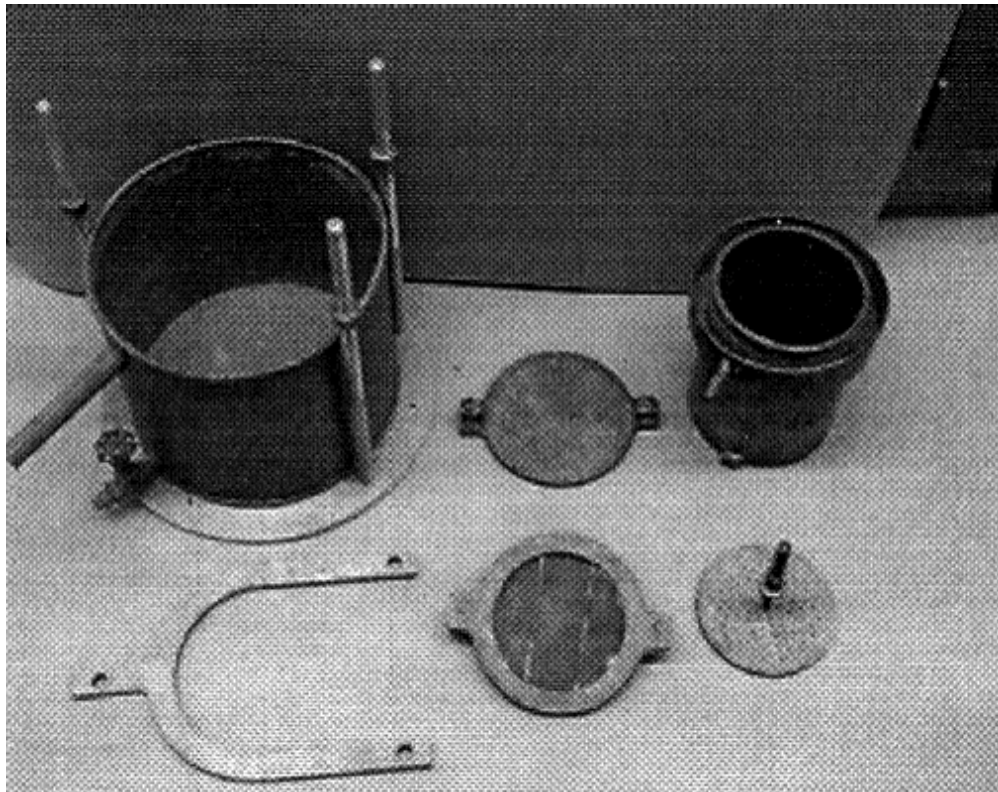

FIGURE 2 - COMPONENT PARTS OF CONSTANT- HEAD PERMEABILITY APPARATUS

C. PREPARATION OF SAMPLE

from which all aggregate retained on the 19-mm sieve has been removed.

1. The specimen consists of a representative portion of the sample under consideration

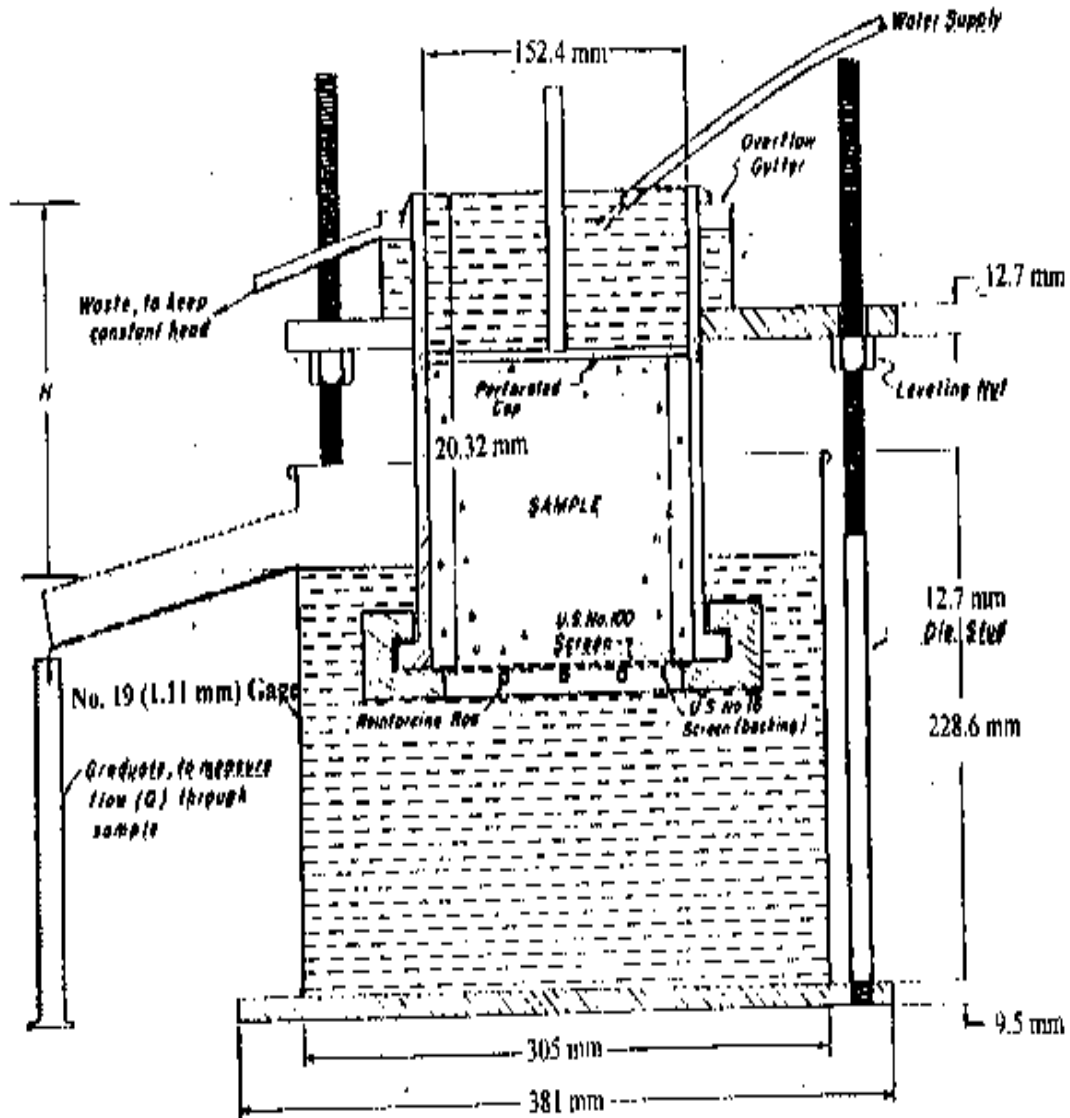

FIGURE 3 - SCHEMATIC DIAGRAM OF APPARATUS FOR CONSTANT-HEAD PERMEABILITY

2. No compensation is made for the plus 19 mm aggregate which has been removed.
3. Use 1000 g of material for a moisture content determination of the air-dried material.
4. Use 5000 g of air-dried material for the permeability test if the sample contains more than 10% retained on the 4.75 mm sieve. Use 4000 g of air-dried material for the permeability test if the sample contains 10% or less retained on the 4.75 mm sieve. The height of compacted specimen should be between 110 mm and 140 mm and it may be necessary to vary the amount depending on the grading and type of material.
5. Use several specimens, 2500 g each, for determination of maximum impact test density. See Method A of California Test 216 for test procedure.
6. Compaction of test specimens:
  - a. Add water to bring the test specimen to slightly below the apparent optimum moisture content, or sufficient water to assure good compaction. Mix the water and material thoroughly with the aid of the soil mixer.
  - b. Compact the wetted specimen in the mold with solid base plate attached, in five equal layers, using the 45.4 kg hammer with a free fall of 457 mm. This compaction equipment is shown in Figure 4. Each layer receives 25 blows, or some other predetermined number of blows. Scarify each compacted layer before adding the next layer.
  - c. After the fifth layer is compacted, set the leveling piston on the specimen and apply five blows with the drop hammer. Invert the mold, compacted specimen, and piston and replace the solid base with the base ring and 150  $\mu$ m mesh sieve. Set the specimen upright, remove the leveling piston and determine the height of the specimen (L) to the nearest 1 mm. Record the average of three or four readings .
  - d. At least three specimens shall be compacted, at different compaction efforts, in order to show a range in permeability with range in density.

#### D. TEST PROCEDURE

1. Fill the 305 mm diameter reservoir to the outlet level with water. Place the perforated plate on the specimen and place the mold and specimen on the "U" shaped hanger to give a head of water of approximately 200 mm. Level the mold with the aid of the nuts on the three vertical studs, and introduce water to the top of the specimen. It may be necessary to use less head if there is an exceptional high rate of flow, "K" of 60 or 90 m/day, (0.07-0.1 cm/sec) or if there is any indication of piping or of passing of fines from the sample during the test.
2. Allow percolation for some time to ensure a high degree of saturation and uniformity of test results.
3. Allow water to run into the intake reservoir at a rate slightly faster than the rate of flow through the specimen. Waste the excess through the intake overflow tube into the sink. The outlet reservoir must be full to the point of overflow before the test is begun. The excess water from the outlet reservoir during the test is the amount that has flowed through the specimen.
4. Determine the quantity of flow (Q) by means of either a graduated container or by weighing, and determine the elapsed time (t) for the quantity of flow. Record these determinations.

entrapped air or migration of fines to the bottom of the test specimen.

- Record the temperature of the water in degrees Celsius ( $^{\circ}\text{C}$ ), head of water (H) and height of sample (L).

#### E. CALCULATIONS AND PLOTTING

- The permeability "K", is calculated from the following formula:

$$K = Q/iAt$$

Q = quantity of water discharged

i = the hydraulic gradient =  $H/L$   
where: H = head of water  
L = height of sample

A = cross-sectional area of specimen

t = elapsed time

- Correct and record the coefficient of permeability, K, to that for  $20^{\circ}\text{C}$ , using the appropriate correction factor from Table 1.

#### F. REPORTING OF RESULTS

Report the test results in tabular form. Be sure to include: project E.A., date, sample number and any other pertinent information. Dry density and relative compaction (%) versus permeability and grain-size distribution can be included on attached graphs.

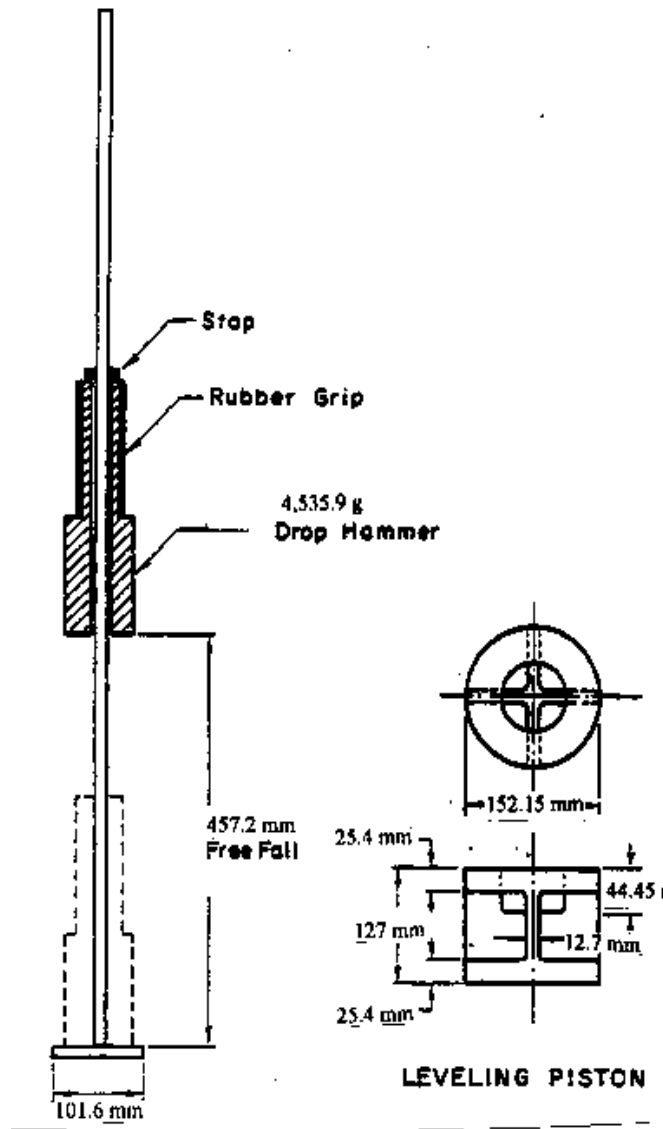

FIGURE 4 - COMPACTION EQUIPMENT FOR CONSTANT- HEAD PERMEABILITY TEST SPECIMEN

- Make several test runs and average the results. If the first reading gives a much higher permeability than the second or third readings, disregard the first reading. The second and third readings are usually in close agreement. Subsequent readings after a prolonged period of time will show a considerable decrease in the rate of flow. This decrease in flow is probably due to

TABLE NO. 1

TEMPERATURE CORRECTION FACTORS

Temp. °C	Factor	Temp. °C	Factor
10	1.3012	20.5	0.9881
10.5	1.2831	21	0.9761
11	1.2650	21.5	0.9646
11.5	1.2476	22	0.9531
12	1.2301	22.5	0.9421
12.5	1.2135	23	0.9311
13	1.1968	23.5	0.9204
13.5	1.1810	24	0.9097
14	1.1651	24.5	0.8995
14.5	1.1499	25	0.8893
15	1.1347	25.5	0.8794
15.5	1.1202	26	0.8694
16	1.1056	26.5	0.8598
16.5	1.0915	27	0.8502
17	1.0774	27.5	0.8410
17.5	1.0640	28	0.8318
18	1.0507	28.5	0.8229
18.5	1.0377	29	0.8139
19	1.0248	29.5	0.8053
19.5	1.0124	30	0.7961
20	1.0000		

- An "O" ring seal is provided to force the water to move through the soil rather than around the outside of the ring.

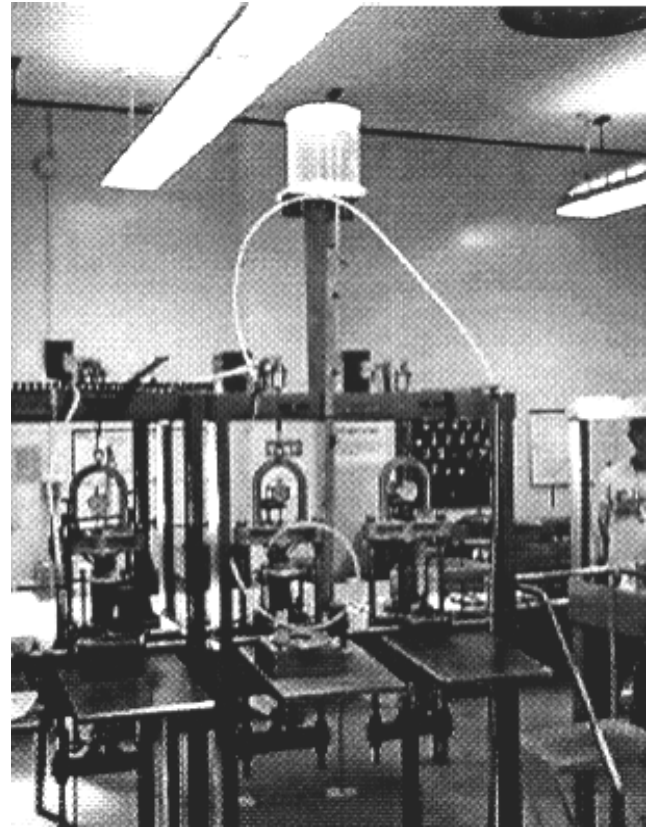

FIGURE 5 - FALLING-HEAD PERMEABILITY APPARATUS

**PART II. FALLING HEAD PERMEABILITY TEST METHOD**

**A. SCOPE**

In this test, water is forced, by a falling head pressure, through a soil specimen of known dimensions and the rate of flow is determined. This test is used to determine the drainage characteristics of relatively fine-grained soils and is usually performed on undisturbed samples.

**B. APPARATUS**

- This test utilizes the same apparatus as an earlier consolidation test with slight modifications; see Figure 5.

**C. CALIBRATION OF EQUIPMENT**

- The entire system, including the porous stones and tubing, must be saturated prior to the test. This can be done by forcing water through the system and allowing the apparatus to stand full of water for a while just before inserting the specimen.
- If the cross-sectional area of the standpipe is not known, it must be measured. This is done by weighing the amount of distilled water contained in a known length of tube. The mass of the water in grams is equal to the volume in mL. From these data, the area and diameter can be computed readily.

The cross-sectional area of the sampler tubing is known to be 1910 mm<sup>2</sup>.

3. Adjust the indicator dials to show a reading of about 0.254 mm when the soil specimen is in place under no load. Make this setting by inserting a 25.4 mm high brass dummy specimen. When the dummy specimen is removed, pour a small amount of water into the consolidometer and replace the piston. This is to allow the porous stones to become saturated prior to the start of the test.

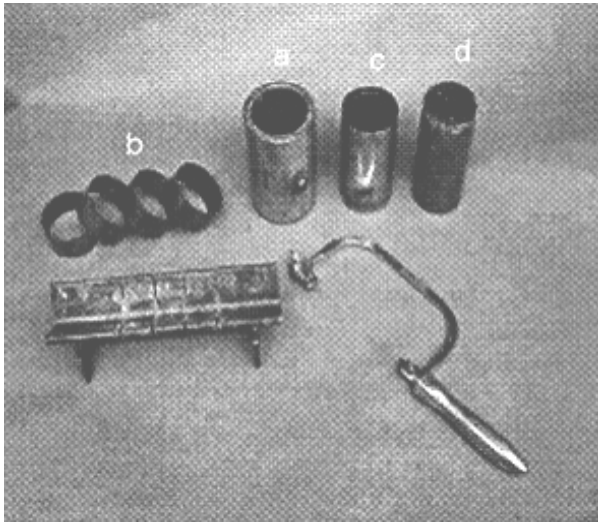

FIGURE 6 – SAMPLE PREP EQUIPMENT

#### D. PREPARATION OF SAMPLE

1. The soil samples are received in the laboratory in the 50.8 mm diameter by 101.6 mm long brass tubes as obtained by the California sampler, or in larger containers from which specimens must be trimmed.
2. The 50.8 mm by 101.6 mm tubes are relatively thin-walled and flexible; therefore, handle them with care so that the soil is not deformed inside the tube.

3. Line the hollow steel cylinder, shown in Figure 6, with four 25.4 mm high segments of sampler tubing. Extrude the soil from the sample tube into the 25.4 mm high consolidometer rings (sampler tubing) by pushing the piston into the sample tube. This extrusion should move the sample in the same direction with reference to the tube as it moved during the sampling operation in order to minimize disturbance of the soil structure.
4. Select one of the four specimens and trim carefully to the exact height of the ring by means of a fine wire saw as shown in Figure 6. Exercise care in these operations so as to disturb the sample as little as possible and to maintain a tight fit of the specimen in the brass ring. Do all the work swiftly to prevent excessive drying of the soil.

#### E. TESTING PROCEDURE

The specimen cannot be placed with the apparatus tipped on its side as the apparatus must be filled with water at all times. The placing procedure requires the following steps:

1. Place soil ring and specimen with “O” ring, on bottom porous stone.
2. Slide consolidometer over soil ring, place upper plate and fasten securely to the base with 3 nuts to ensure “O” ring seal.
3. Insert top porous stone and piston which applies a 6.0 kPa pressure on the specimen. Record initial dial reading to determine subsequent change in specimen height, for unit weight calculations, due to increasing load increments.
4. Bleed air out of the system by allowing water to flow from the reservoir across the bottom porous stone and also through the conduit system. It is imperative that all air bubbles be flushed out of the system. Close the bleeding valve in the base of apparatus.

5. Record initial dial reading, then apply the load. Record final dial reading.
6. Fill standpipe. Record the height of water in the tube.
7. Release the quick-acting flow valve and the test is in progress.
8. Record time in seconds for head of water to fall to the level of the overflow pipe.
9. Repeat steps 6 through 8 several times to establish an average permeability for each load increment used.

#### F. CALCULATIONS

Compute the coefficient of permeability from the following formula:

$$K = 2.3 (aL/At) \log_{10} (h_1/h_2)$$

Where:

K = coefficient of permeability.

a = cross-sectional area of the standpipe.

L = average height of the sample for the load increment.

A = cross-sectional area of the sample.

t = elapsed time increment.

$h_1$  = height of water at the beginning of time increment in millimeters .

$h_2$  = height of water at the end of time increment in millimeters .

The necessary accompanying data should include (1) boring, sample, and tube numbers, (2) soil description, (3) initial and final water contents, and (4) dry mass of soil.

#### G. NOTES

The most common use of this test is in connection with the studies where drainage and settlement of soft foundation soils are involved. This test can serve as a check on the consolidation test results.

The quantity of water that will flow through a relatively fine-grained soil is so small that the presence of fissures or entrapped air may seriously affect the results obtained. The use of the quantitative results obtained with this test are usually questionable. The test may serve a useful purpose in comparing the permeabilities of two soils or in comparing the permeabilities of a soil in horizontal and vertical directions. Such information is valuable in the design of projects where vertical sand drains are used.

#### H. REPORTING OF RESULTS

Report test results in tabular form or on soil profile sheets.

#### I. SAFETY AND HEALTH

Prior to handling, testing or disposing of any waste materials, testers are required to read: Part A (Section 5.0), Part B (Sections: 5.0, 6.0 and 10.0) and Part C (Section 1.0) of Caltrans' Laboratory Safety Manual.

Users of this method do so at their own risk.

#### REFERENCE: California Test 219

End of Text (California Test 220 contains 8 pages)